

Features

- 100V/100A
RDS(ON)=7.1mΩ (typ.)@ VGS=10V
- Lead free and Green Device Available
- Low Rds-on to Minimize Conductive Loss
- High avalanche Current
- 100% Avalanche Tested

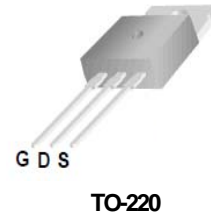
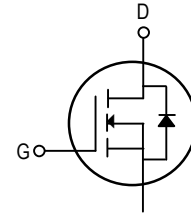

Application

- Power Supply
- DC-DC Converters
- UPS
- Battery Management System

Absolute Maximum Ratings (T_A=25°C unless otherwise noted)

Symbol	Parameter	Maximum	Unit
V _{DSS}	Drain-to-Source Voltage	100	V
V _{GSS}	Gate-to-Source Voltage	±25	V
I _D ³	Continuous Drain Current	T _C =25°C	100
		T _C =100°C	80
I _{DM} ⁴	Pulsed Drain Current	400	A
EAS ⁵	Avalanche energy	313	
PD	Maximum Power Dissipation	200	W
T _J , T _{STG}	Junction & Storage Temperature Range	-55~175	°C

Thermal Characteristics

Symbol	Parameter	Typical	Unit
Rθjc	Thermal Resistance-Junction to Case	0.63	°C/W
Rθja	Thermal Resistance-Junction to Ambient	62.5	

Electrical Characteristics (TA=25°C unless otherwise noted)

Symbol	Parameter	Test Conditions	Min.	Typ	Max.	Unit
Static Characteristics						
BV_{DSS}	Drain-Source Breakdown Voltage	$V_{GS}=0V, I_D=250\mu A$	100	—	—	V
I_{DSS}	Zero Gate Voltage Drain Current	$V_{DS}=100V, V_{GS}=0V$	—	—	1	μA
$V_{GS(th)}$	Gate Threshold Voltage	$V_{DS}=V_{GS}, I_D=250\mu A$	2	3	4	V
I_{GSS}	Gate Leakage Current	$V_{GS}=\pm 25V, V_{DS}=0V$	—	—	± 100	nA
$R_{DS(on)}^1$	Drain-Source On-Resistance	$V_{GS}=10V, I_D=50A$	—	7.1	8.8	m Ω
			—	—	—	
Diode Characteristics						
V_{SD}^1	Diode Forward Voltage	$I_{SD}=50A, V_{GS}=0V$	—	0.9	1.3	V
I_S^3	Diode Continuous Forward Current		—	—	97	A
t_{rr}	Reverse Recovery Time	$I_S=50A,$	—	45	—	nS
Q_{rr}	Reverse Recovery Charge	$dI/dt=100A/\mu s$	—	65	—	nC
Dynamic Characteristics²						
C_{iss}	Input Capacitance	$V_{GS}=0V, V_{DS}=25V$ Frequency=1MHz	—	3260	—	pF
C_{oss}	Output Capacitance		—	370	—	
C_{riss}	Reverse Transfer Capacitance		—	301	—	
$t_{d(on)}$	Turn-On Delay Time	$V_{DS}=50V, I_D=50A,$ $V_{GS}=10V, (Note 1, 4)$	—	29	—	nS
t_r	Rise Time		—	57	—	
$t_{d(off)}$	Turn-Off Delay Time		—	77	—	
t_f	Fall Time		—	35	—	
Gate Charge Characteristics²						
Q_g	Total Gate Charge	$V_{DS}=80V, I_D=50A,$ $V_{GS}=10V, (Note 1, 4)$	—	103	—	nC
Q_{gs}	Gate-to-Source Charge		—	24	—	
Q_{gd}	Gate-to-Drain Charge		—	43	—	

Note: 1: Pulse test; pulse width $\leq 300\mu s$, duty cycle $\leq 2\%$.

2: Guaranteed by design, not subject to production testing.

3: Package limitation current is 100A. Calculated continuous current based on maximum allowable junction temperature.

4: Repetitive rating, pulse width limited by max junction temperature.

5: Starting $T_J = 25^\circ C, L = 1mH, I_{AS} = 25A$.

Typical Characteristics

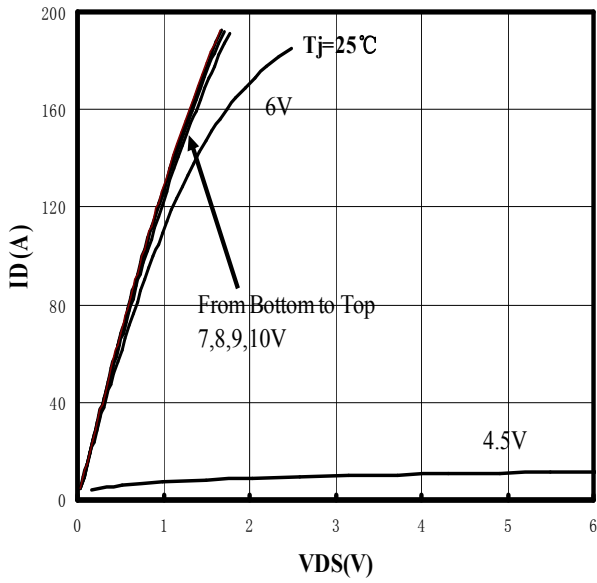

Figure 1. Typ. Output Characteristics

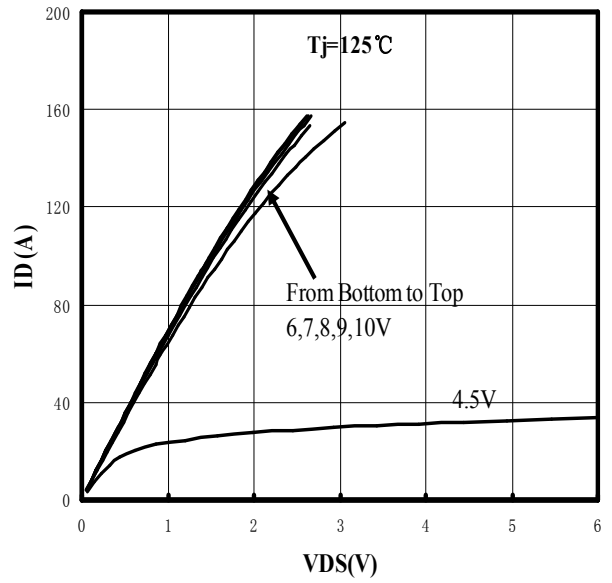

Figure 2. Typ. Output Characteristics

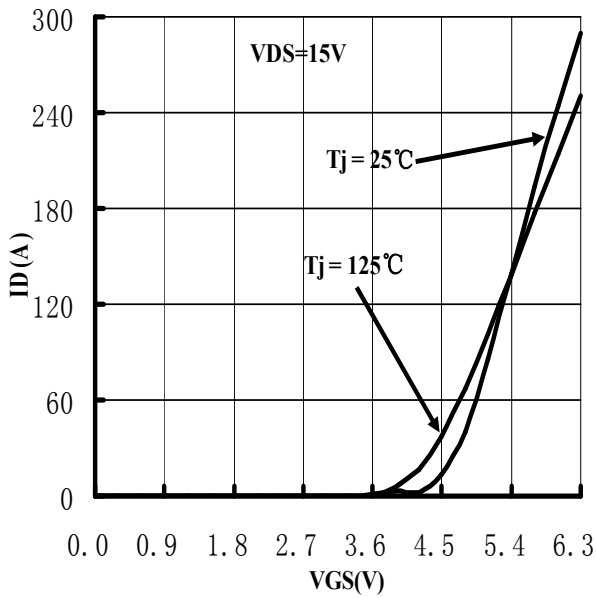

Figure 3. Transfer Characteristics

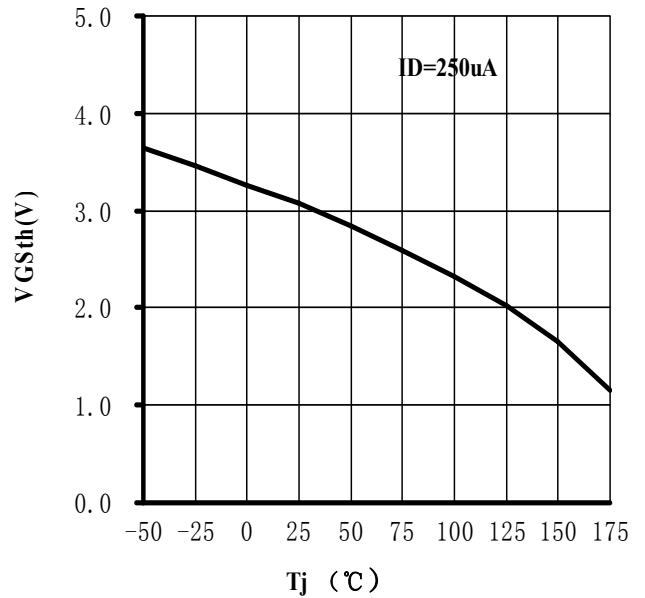

Figure 4. Gate Threshold Voltage Characteristics

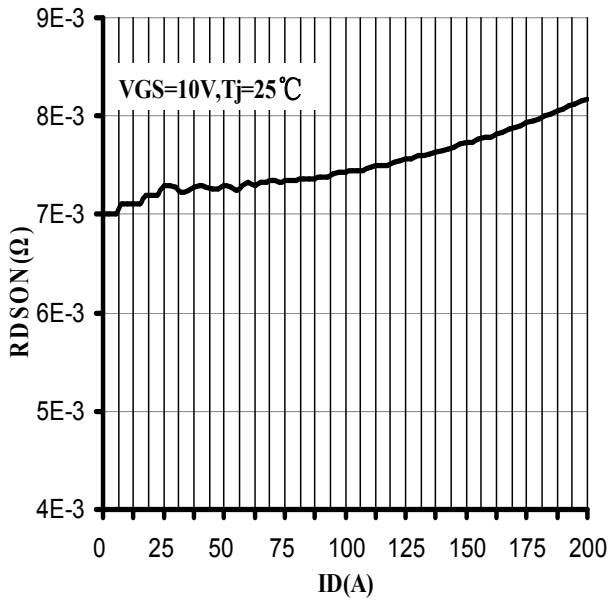

Figure 5. Rdson vs. Drain Current Characteristics

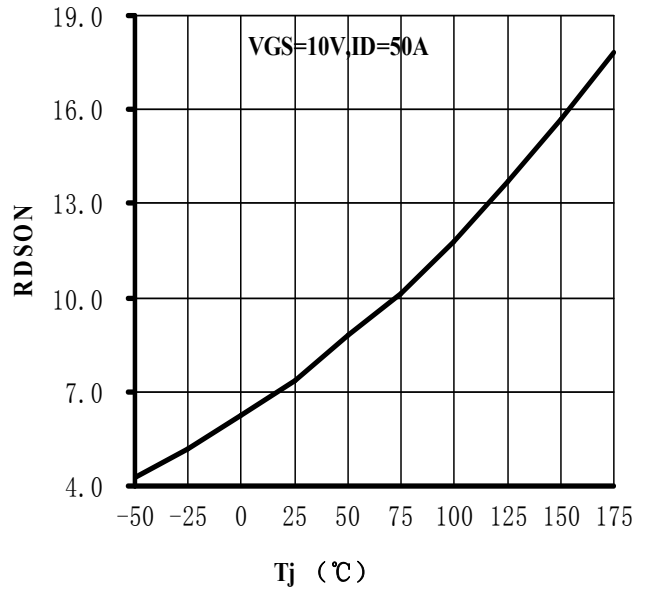

Figure 6. Rdson vs. Junction Tem Characteristics

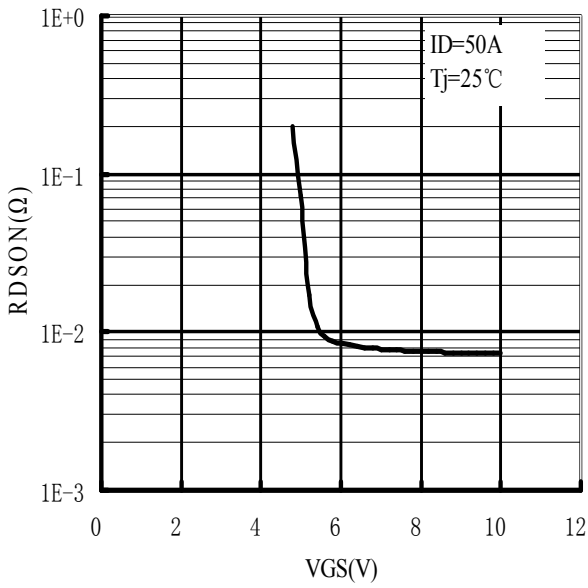

Figure 7. Rdson vs. VGS Characteristics

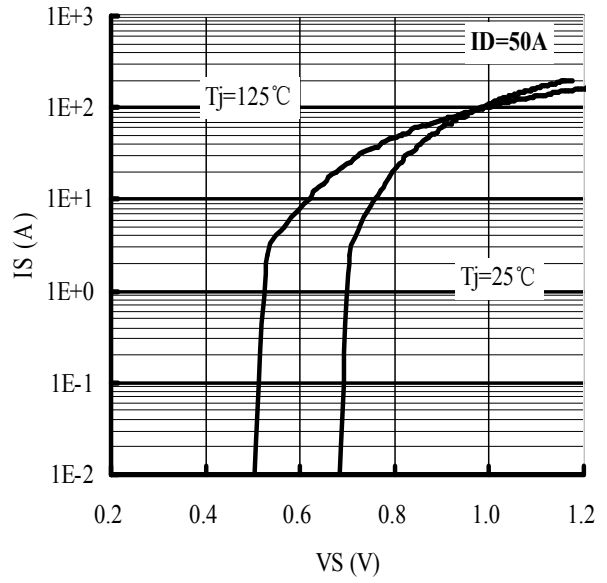

Figure 8. IS vs. VSD Characteristics

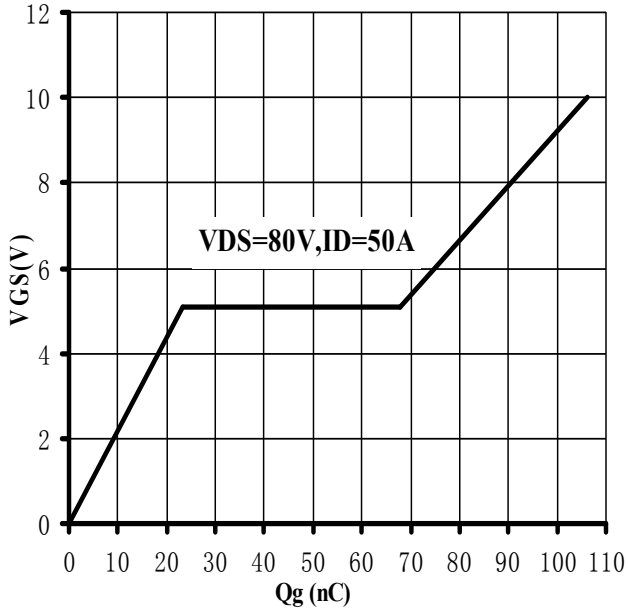

Figure 9. Gate Charge Characteristics

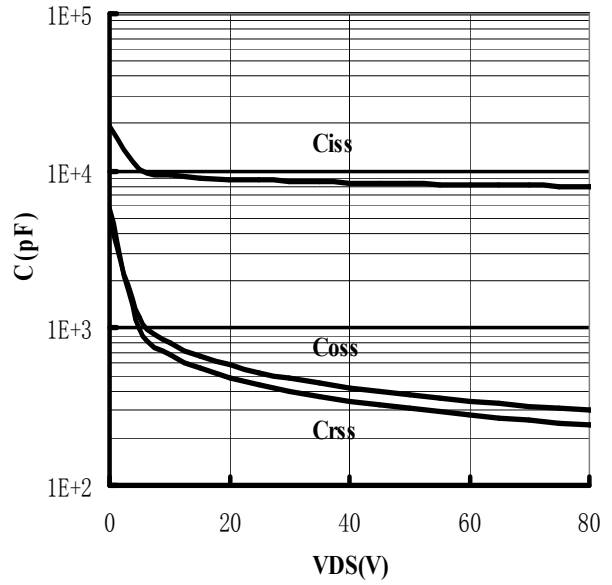

Figure 10. Capacitance Characteristics

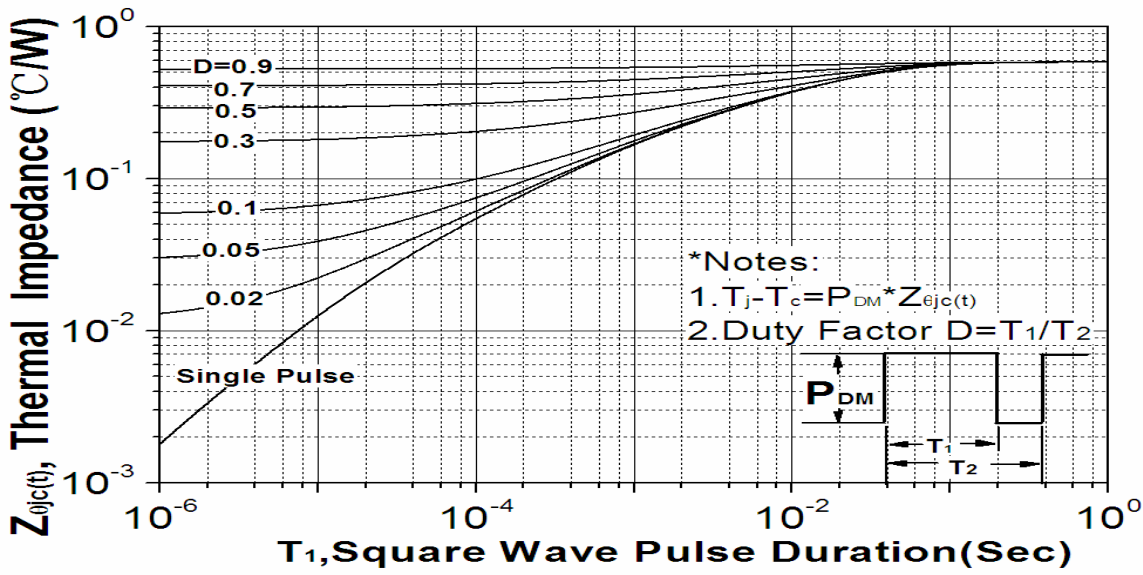
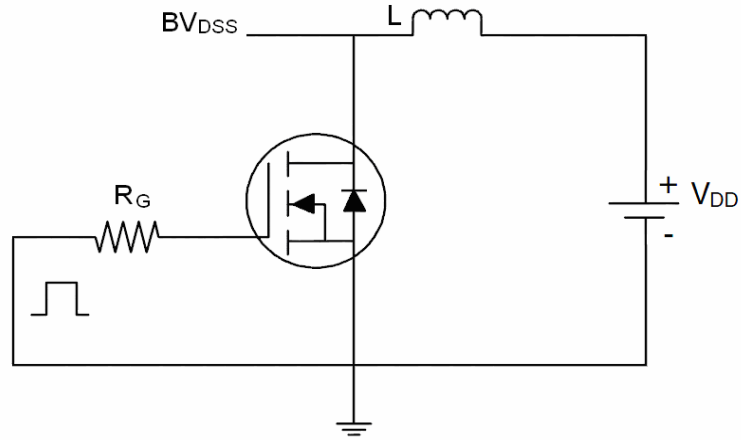

Figure 11. Thermal Resistance Characteristics

Test Circuit

1) E_{AS} test Circuit



2) Gate charge test Circuit

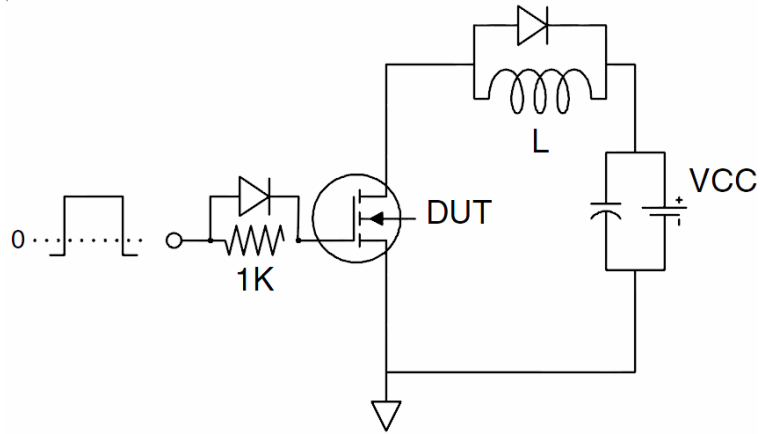

3) Switch Time Test Circuit

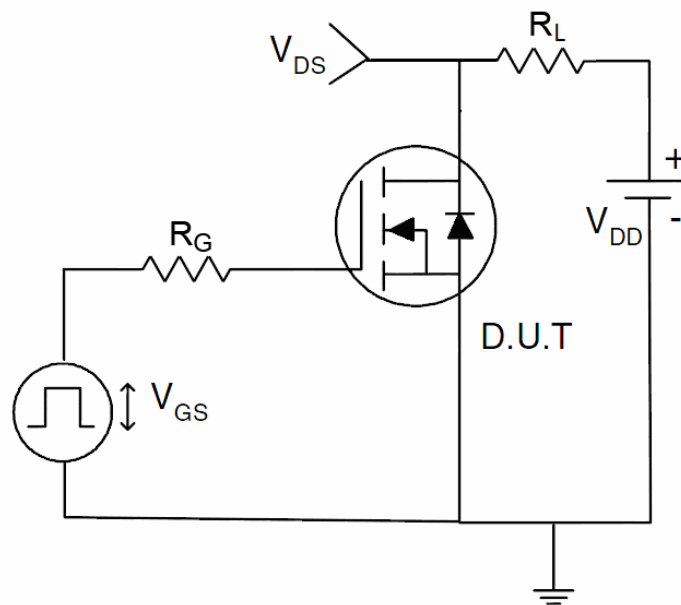

X-ON Electronics

Largest Supplier of Electrical and Electronic Components

Click to view similar products for [MOSFET](#) category:

Click to view products by [PUOLOP](#) manufacturer:

Other Similar products are found below :

[614233C](#) [648584F](#) [NTNS3A92PZT5G](#) [IRFD120](#) [IRFF430](#) [JANTX2N5237](#) [2N7000](#) [2SK2464-TL-E](#) [FCA20N60_F109](#) [FDZ595PZ](#) [AOD464](#)
[2SK2267\(Q\)](#) [2SK2545\(Q,T\)](#) [405094E](#) [423220D](#) [MIC4420CM-TR](#) [VN1206L](#) [614234A](#) [715780A](#) [SSM6J414TU,LF\(T](#) [751625C](#)
[IPP60R600P6XKSA1](#) [RJK60S5DPK-M0#T0](#) [PSMN4R2-30MLD](#) [TK31J60W5,S1VQ\(O](#) [2SK2614\(Te16L1,Q\)](#) [DMN1017UCP3-7](#)
[EFC2J004NUZTDG](#) [FCAB21350L1](#) [P85W28HP2F-7071](#) [DMN1053UCP4-7](#) [NTE2384](#) [NTE2969](#) [NTE6400A](#) [DMN61D9UWQ-13](#)
[US6M2GTR](#) [DMN31D5UDJ-7](#) [SSM6P54TU,LF](#) [DMP22D4UFO-7B](#) [IPS60R3K4CEAKMA1](#) [DMN1006UCA6-7](#) [DMN16M9UCA6-7](#)
[STF5N65M6](#) [STU5N65M6](#) [C3M0021120D](#) [DMN13M9UCA6-7](#) [BSS340NWH6327XTSA1](#) [MCM3400A-TP](#) [DMTH10H4M6SPS-13](#)
[IRF40SC240ARMA1](#)