

Features

- For WCDMA applications
- Usable 1 dB bandwidth of 20 MHz
- Low loss
- Single-ended operation at 50 Ω
- Single-ended input \ balanced output at 200 Ω
- Ceramic Surface Mount Package (SMP)
- Hermetic
- **RoHS** compliant (2002/95/EC), **Pb-free** 

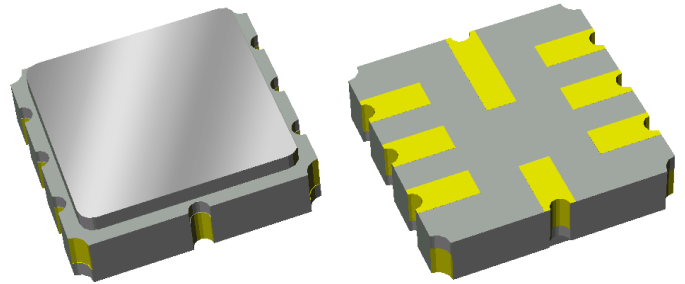

Package

Surface Mount 5.00 x 5.00 x 1.32 mm
SMP-20A

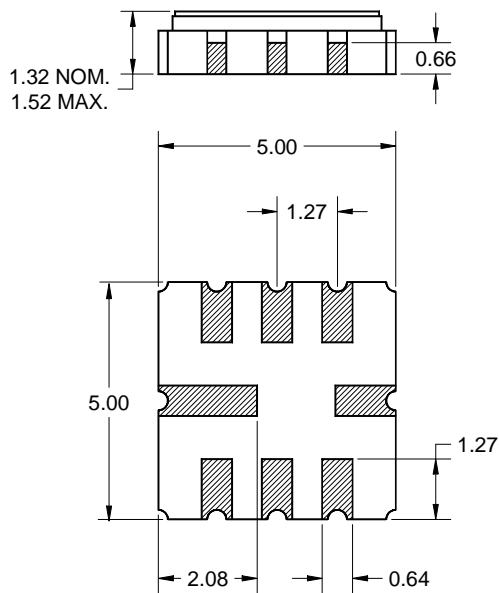

Dimensions shown are nominal in millimeters
All tolerances are ± 0.15 mm except overall
length and width $+0.15/-0.10$ mm

Body: Al_2O_3 ceramic
Lid: Kovar, Ni plated
Terminations: Au plating 0.5 - 1.0 μ m,
over a 2 - 6 μ m Ni plating

Pin Configuration

Bottom View

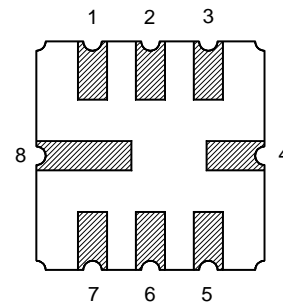

SE - Balanced Configuration

Pin No.	Description
7	Input +
3	Output +
2	Output -
1,6,5	Ground
4,8	Case Ground

Single-ended Configuration

Pin No.	Description
3	Input
7	Output
1,2,5,6	Ground
4,8	Case Ground

Electrical Specifications ⁽¹⁾

Operating Temperature Range: ⁽²⁾ -20 to +80 °C

Parameter ⁽³⁾	Minimum	Typical ⁽⁴⁾	Maximum	Unit
Center Frequency	-	168.5	-	MHz
Minimum Insertion Loss 158.5 – 178.5 MHz	-	8.0	9.0	dB
1.0 dB Bandwidth	22	26.4	-	MHz
Amplitude Variation 158.5 – 178.5 MHz	-	0.6	1.0	dB
Group Delay Ripple 158.5 – 178.5 MHz 160.5 – 176.5 MHz	- -	20 20	40 40	nsec nsec
Relative Attenuation ⁽⁵⁾ 10 – 100 MHz 100 – 149 MHz 149 – 150.5 MHz 150.5 – 153.5 MHz 183.5 – 186.5 MHz 186.5 – 190 MHz 190 – 250 MHz 250 – 310 MHz 310 – 410 MHz 410 – 1000 MHz	50 33 20 3 2 19 33 40 50 55	61 41 32 6.5 4.5 32 42 56 59 59	- - - - - - - - - -	dB dB dB dB dB dB dB dB dB dB
Input/Output Return Loss 158.5 – 178.5 MHz	10	14	-	dB
EVM 158.5 – 163.5 MHz 163.5 – 168.5 MHz 168.5 – 173.5 MHz 173.5 – 178.5 MHz	- - - -	1.2 1.2 1.2 1.3	2.5 2.6 2.5 2.5	% % % %
Source Impedance (single-ended) ⁽⁶⁾ Load Impedance (single-ended) ⁽⁶⁾ Load Impedance (balanced) ⁽⁶⁾	- - -	50 50 200	- - -	Ω Ω Ω

Notes:

1. All specifications are based on the TriQuint test circuit matching schematics shown on page 5
2. In production, devices will be tested at room temperature to a guardbanded specification to ensure electrical compliance over temperature
3. Electrical margin has been built into the design to account for the variations due to temperature drift and manufacturing tolerances
4. Typical values are based on average measurements at room temperature
5. Relative to minimum insertion loss
6. This is the optimum impedance in order to achieve the performance shown

Electrical Specifications ⁽¹⁾

Operating Temperature Range: ⁽²⁾ -40 to +85 °C

Parameter ⁽³⁾	Minimum	Typical ⁽⁴⁾	Maximum	Unit
Center Frequency	-	168.5	-	MHz
Minimum Insertion Loss 158.5 – 178.5 MHz	-	8.0	9.0	dB
1.0 dB Bandwidth	22	26.4	-	MHz
Amplitude Variation 158.5 – 178.5 MHz	-	0.6	1.0	dB
Group Delay Ripple 158.5 – 178.5 MHz 160.5 – 176.5 MHz	- -	20 20	50 40	nsec nsec
Relative Attenuation ⁽⁵⁾ 10 – 100 MHz 100 – 149 MHz 149 – 150.5 MHz 150.5 – 153.5 MHz 183.5 – 186.5 MHz 186.5 – 190 MHz 190 – 250 MHz 250 – 310 MHz 310 – 410 MHz 410 – 1000 MHz	50 33 19 2.5 1.8 16 33 40 50 55	61 41 32 6.5 4.5 32 42 56 59 59	- - - - - - - - - -	dB dB dB dB dB dB dB dB dB dB
Input/Output Return Loss 158.5 – 178.5 MHz	10	14	-	dB
EVM 158.5 – 163.5 MHz 163.5 – 168.5 MHz 168.5 – 173.5 MHz 173.5 – 178.5 MHz	- - - -	1.2 1.2 1.2 1.3	3.5 3.5 3 3	% % % %
Source Impedance (single-ended) ⁽⁶⁾ Load Impedance (single-ended) ⁽⁶⁾ Load Impedance (balanced) ⁽⁶⁾	- - -	50 50 200	- - -	Ω Ω Ω

Notes:

1. All specifications are based on the TriQuint test circuit matching schematics shown on page 5
2. In production, devices will be tested at room temperature to a guardbanded specification to ensure electrical compliance over temperature
3. Electrical margin has been built into the design to account for the variations due to temperature drift and manufacturing tolerances
4. Typical values are based on average measurements at room temperature
5. Relative to minimum insertion loss
6. This is the optimum impedance in order to achieve the performance shown

Typical Performance (at room temperature)

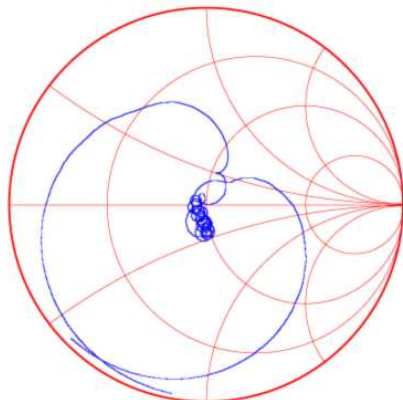
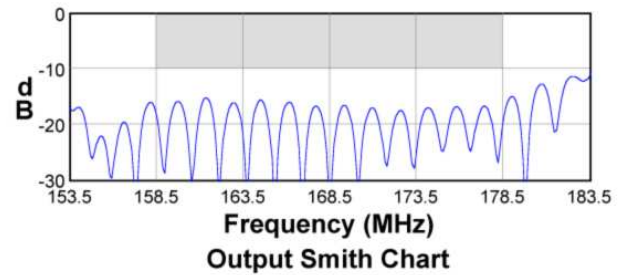
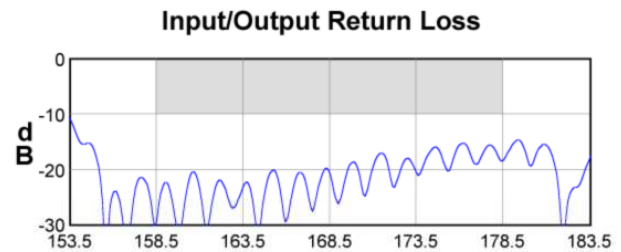
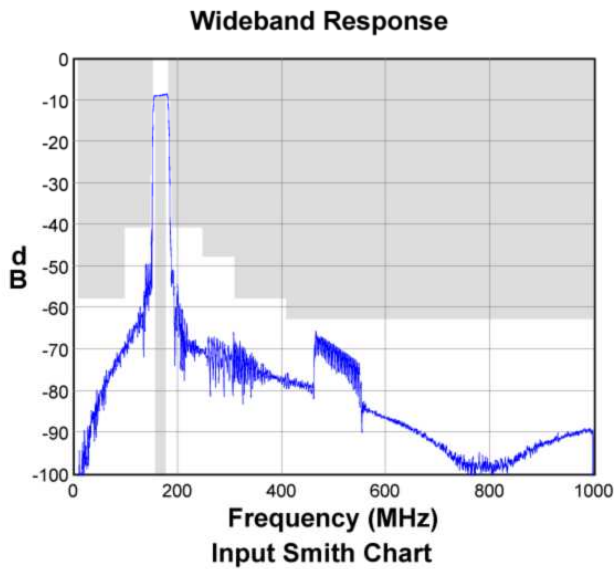
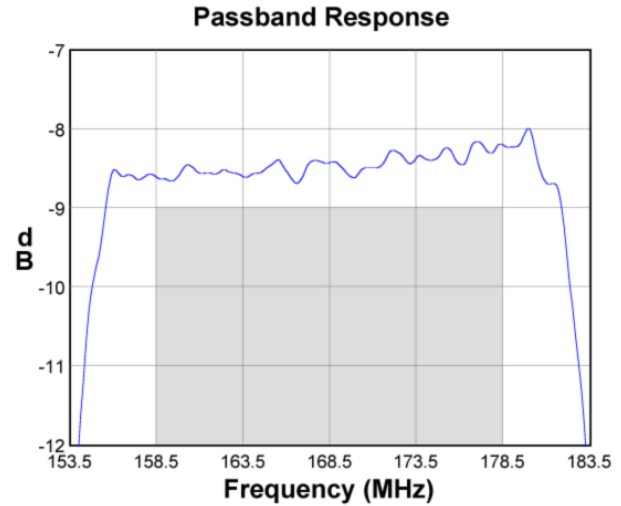
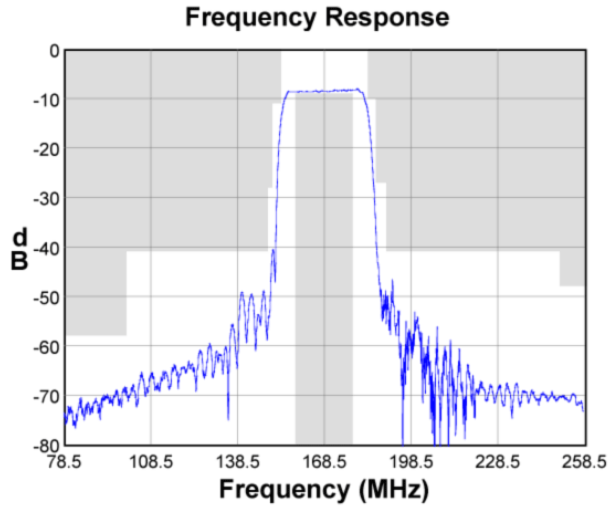

Matching Schematics

Actual matching values may vary due to PCB layout and parasitics

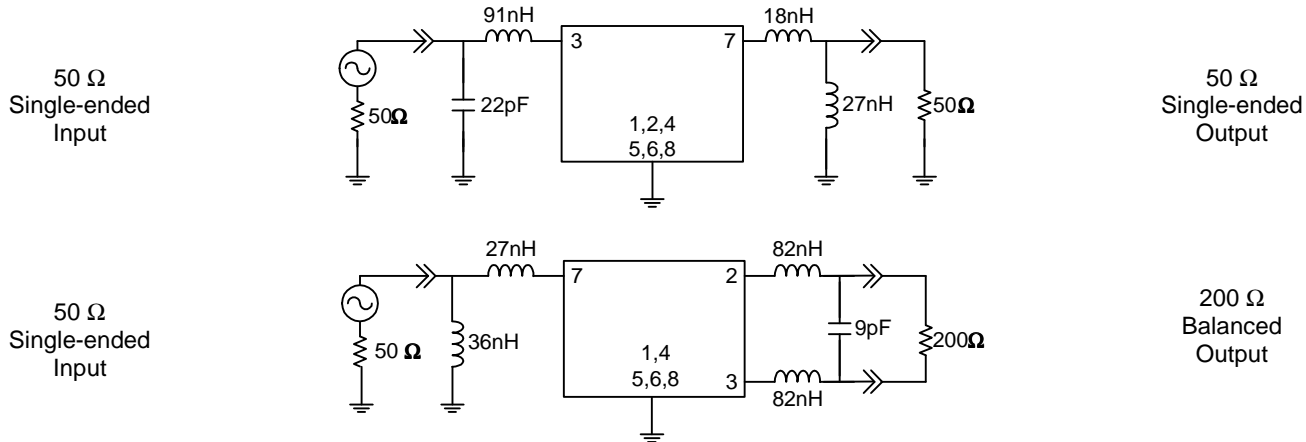

Marking

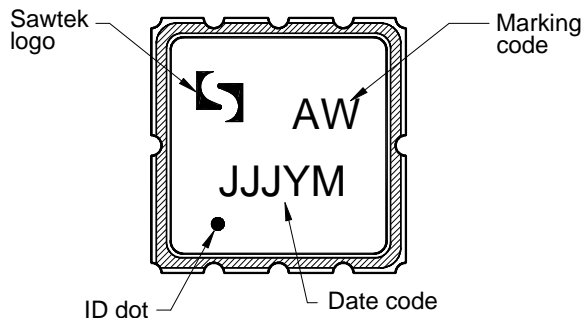

The date code consists of: JJJ = Julian day,
Y = last digit of year, M = manufacturing site code

PCB Footprint

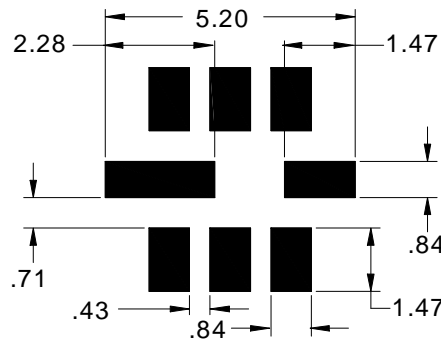

This footprint represents a recommendation only
Dimensions shown are nominal in millimeters

Tape and Reel

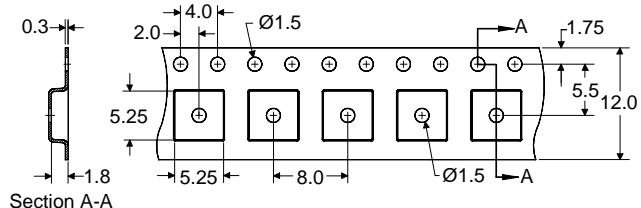
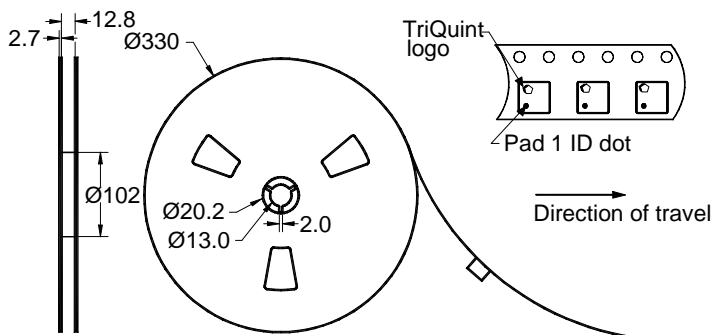

Dimensions shown are nominal in millimeters
Packaging quantity: 4000 units/reel

Maximum Ratings

Parameter	Symbol	Minimum	Maximum	Unit
Operating Temperature Range	T	-40	+85	°C
Storage Temperature Range	T _{stg}	-40	+85	°C

Important Notes

Warnings

- Electrostatic Sensitive Device (ESD) 
- Avoid ultrasonic exposure

RoHS Compliance

- This product complies with EU directive 2002/95/EC (RoHS) 

Solderability

- Compatible with JESD22-B102, Pb-free process, 260C peak reflow temperature ([see soldering profile](#))

Links to Additional Technical Information

[PCB Layout Tips](#)

[Qualification Flowchart](#)

[Soldering Profile](#)

[S-Parameters](#)

[RoHS Information](#)

[Other Technical Information](#)

TriQuint's liability is limited only to the Surface Acoustic Wave (SAW) component(s) described in this data sheet. TriQuint does not accept any liability for applications, processes, circuits or assemblies, which are implemented using any TriQuint component described in this data sheet.

Contact Information

TriQuint 
SEMICONDUCTOR

PO Box 609501
Orlando, FL 32860-9501
USA

Phone: +1 (407) 886-8860
Fax: +1 (407) 886-7061
Email: info-product@tqs.com
Web: www.triquint.com

Or contact one of our worldwide
Network of [sales offices](#),
[Representatives or distributors](#)

X-ON Electronics

Largest Supplier of Electrical and Electronic Components

Click to view similar products for [Sub-GHz Development Tools](#) category:

Click to view products by [Qorvo](#) manufacturer:

Other Similar products are found below :

[EVAL-ADF7021DBJZ](#) [EVAL-ADF7021-NDBZ2](#) [EVAL-ADF7021-VDB3Z](#) [EVAL-ADF7023DB3Z](#) [MICRF219A-433 EV](#) [MICRF220-433 EV](#) [AD6679-500EBZ](#) [EVAL-ADF7901EBZ](#) [EVAL-ADF790XEBZ](#) [110976-HMC453QS16G](#) [STEVAL-IKR002V7D](#) [MAX2602EVKIT+](#) [MAX1472EVKIT-315](#) [MAX1479EVKIT-315](#) [STEVAL-IKR002V3D](#) [MAX7042EVKIT-315+](#) [MAX2902EVKIT#](#) [MAX9947EVKIT+](#) [MAX1470EVKIT-315](#) [SKY66188-11-EK1](#) [SKY66013-11-EVB](#) [EVAL-ADF7023DB5Z](#) [DRF1200/CLASS-E 1096](#) [1098](#) [MDEV-900-PRO](#) [DVK-SFUS-1-GEVK](#) [DVK-SFUS-API-1-GEVK](#) [US-SIGFOX-GEVB](#) [STEVAL-IKR002V2D](#) [107755-HMC454ST89](#) [DM182017-2](#) [110961-HMC453ST89](#) [DM182017-1](#) [SX1272MB2DAS](#) [3179](#) [DC689A](#) [DC1513B-AB](#) [3229](#) [3230](#) [3231](#) [3232](#) [DC1250A-AA](#) [DC1513B-AC](#) [DC1513B-AD](#) [DC1513B-AA](#) [TEL0075](#) [131903-HMC921LP4E](#) [EU-SIGFOX-GEVB](#) [856512-EVB](#)