

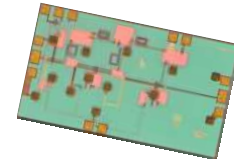

Let Performance Drive

CMD190

33-45 GHz Low Noise Amplifier



Features

- ▶ Ultra low noise performance
- ▶ All positive bias
- ▶ Low current consumption
- ▶ Small die size

Applications

- ▶ Point-to-point radios
- ▶ Point-to-multi-point radios
- ▶ Military and space

Description

The CMD190 is a highly efficient GaAs MMIC low noise amplifier ideally suited for EW and communications systems where small size and low power consumption are needed. The device operates from 33 to 45 GHz and delivers greater than 19 dB of gain with a corresponding noise figure of 2.1 dB at 36 GHz. The CMD190 is a 50 ohm matched design which eliminates the need for external DC blocks and RF port matching. The CMD190 offers full passivation for increased reliability and moisture protection.

Functional Block Diagram

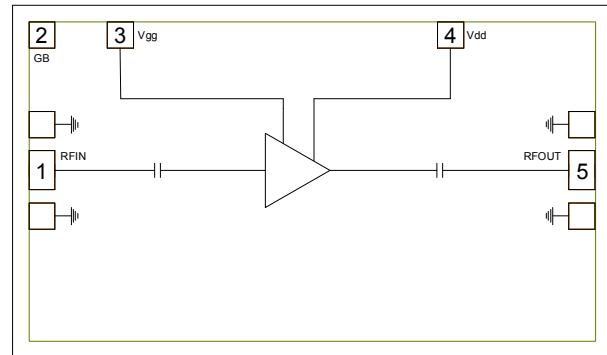

Electrical Performance - $V_{dd} = 2.0\text{ V}$, $V_{gg} = 2.0\text{ V}$, $T_A = 25\text{ }^\circ\text{C}$, $F=36\text{ GHz}$

Parameter	Min	Typ	Max	Units
Frequency Range	33 - 45			GHz
Gain		19		dB
Noise Figure		2.1		dB
Input Return Loss		17		dB
Output Return Loss		13		dB
Output P1dB		4		dBm
Supply Current		25		mA

ver 1.1 1114

Specifications

Absolute Maximum Ratings

Parameter	Rating
Drain Voltage, V _{dd}	5.0 V
Gate Voltage, V _{gg}	3.0 V
RF Input Power	+20 dBm
Channel Temperature, T _{ch}	150 °C
Power Dissipation, P _{diss}	268 mW
Thermal Resistance	242 °C/W
Operating Temperature	-55 to 85 °C
Storage Temperature	-55 to 150 °C

Operation of this device outside the maximum ratings may cause permanent damage.

Recommended Operating Conditions

Parameter	Min	Typ	Max	Units
V _{dd}	1.0	2.0	4.0	V
I _{dd}		25		mA
V _{gg}	0	2.0	3.0	V

Electrical performance is measured at specific test conditions. Electrical specifications are not guaranteed over all recommended operating conditions.

Electrical Specifications, V_{dd} = 2.0 V, V_{gg} = 2.0 V, T_A = 25 °C

Parameter	Min	Typ	Max	Min	Typ	Max	Min	Typ	Max	Units
Frequency Range	33 - 36			36 - 40			40 - 45			GHz
Gain	17	21	25	13	17	22	13	15.5	19	dB
Noise Figure		2.1	2.6		2.5	3		2.75	3.6	dB
Input Return Loss		17			18			18		dB
Output Return Loss		11			10			10		dB
Output P1dB		4			4			4		dBm
Output IP3		12.5			13.5			14		dBm
Supply Current	17	25	33	17	25	33	17	25	33	mA
Gain Temperature Coefficient		0.02			0.02			0.02		dB/°C
Noise Figure Temperature Coefficient		0.012			0.012			0.012		dB/°C

ver 1.1 1114

Typical Performance

Broadband Performance, $V_{dd} = 2.0\text{ V}$, $V_{gg} = 2.0\text{ V}$, $I_{dd} = 25\text{mA}$, $T_A = 25\text{ }^\circ\text{C}$

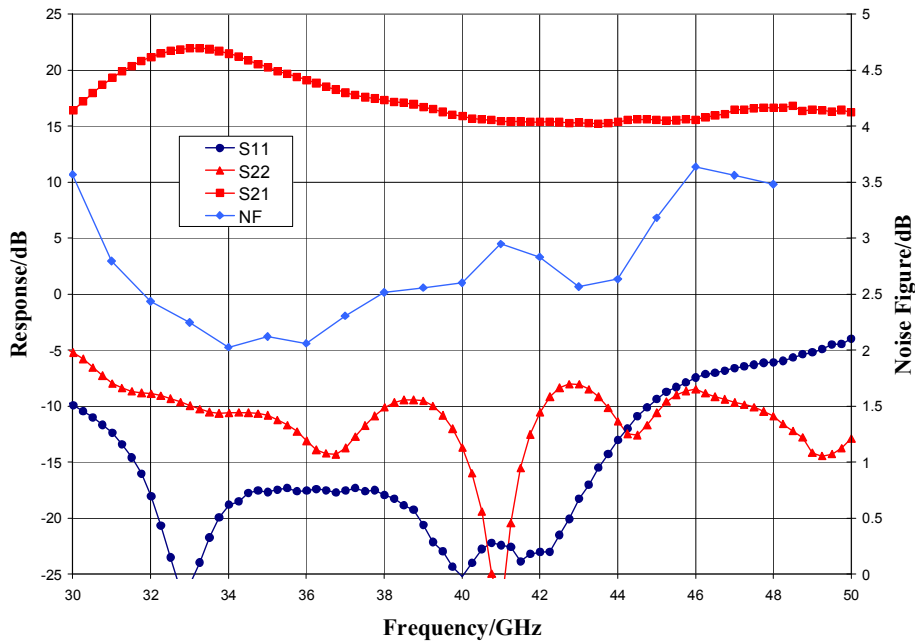

Narrow-band Performance, $V_{dd} = 2.0\text{ V}$, $V_{gg} = 2.0\text{ V}$, $I_{dd} = 25\text{ mA}$, $T_A = 25\text{ }^\circ\text{C}$

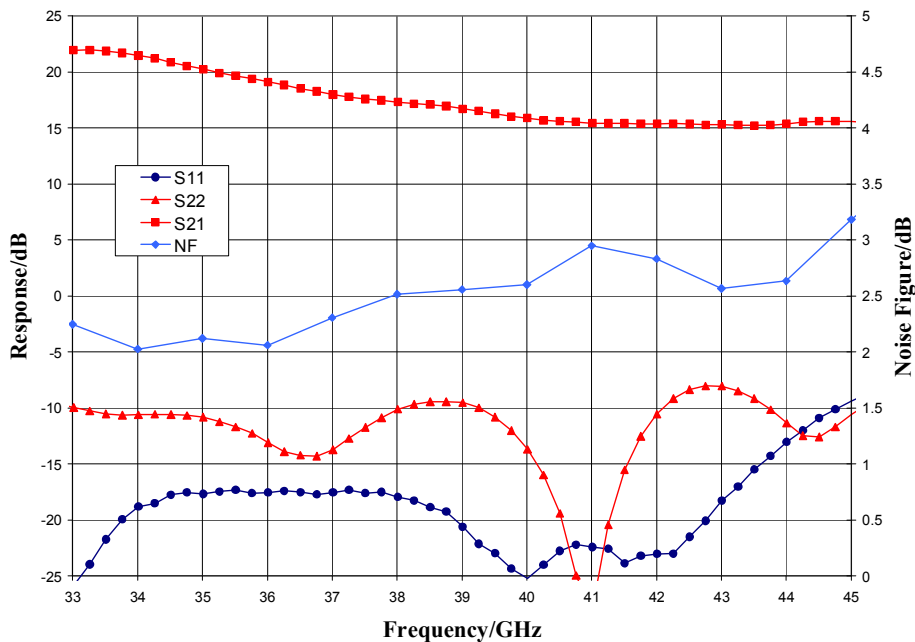

ver 1.1 1114

Typical Performance

Gain vs. Temperature, $V_{dd} = 2.0\text{ V}$, $V_{gg} = 2.0\text{ V}$

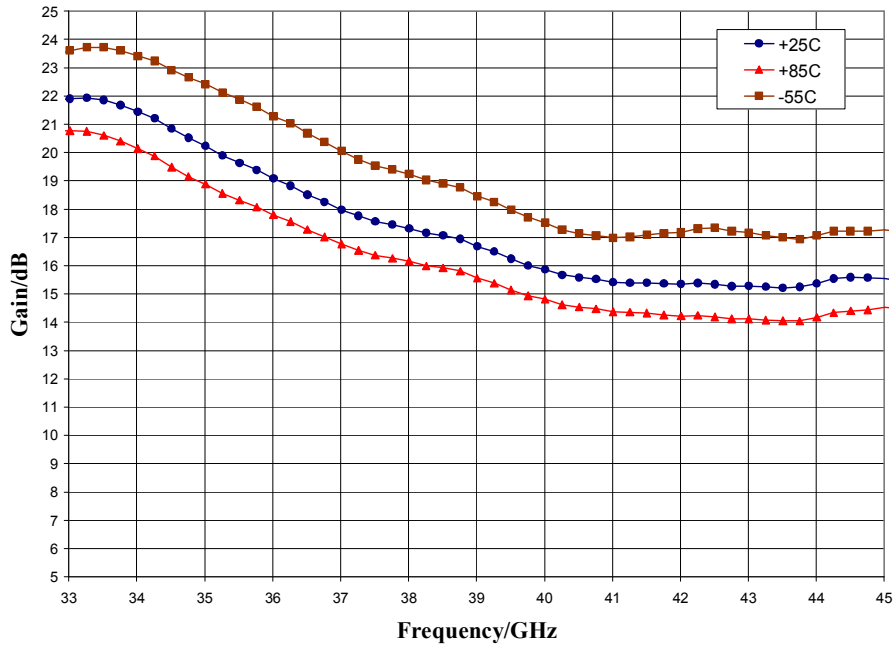

Noise Figure vs. Temperature, $V_{dd} = 2.0\text{ V}$, $V_{gg} = 2.0\text{ V}$

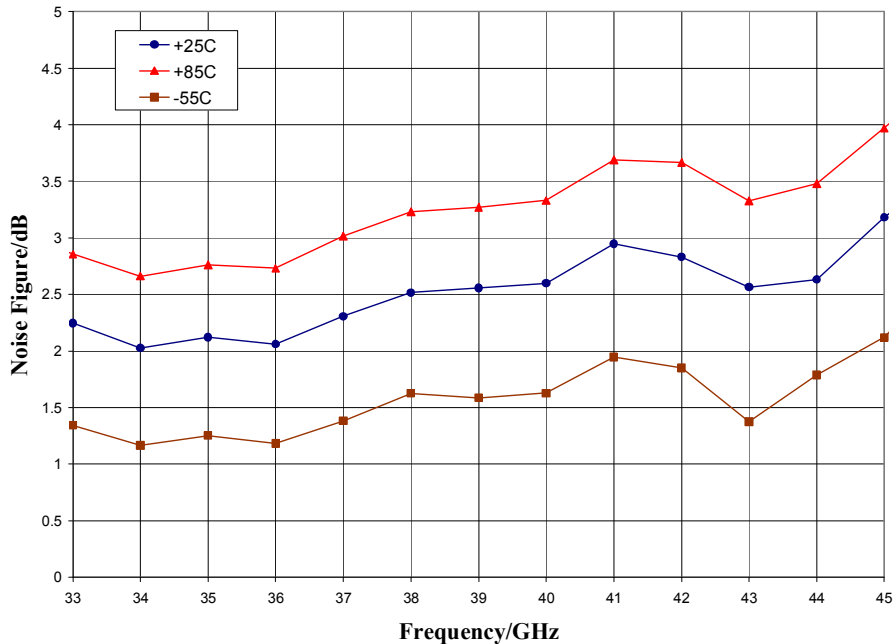

ver 1.1 1114

Typical Performance

Output Power, $V_{dd} = 2.0\text{ V}$, $V_{gg} = 2.0\text{ V}$, $I_{dd} = 25\text{ mA}$, $T_A = 25\text{ }^\circ\text{C}$

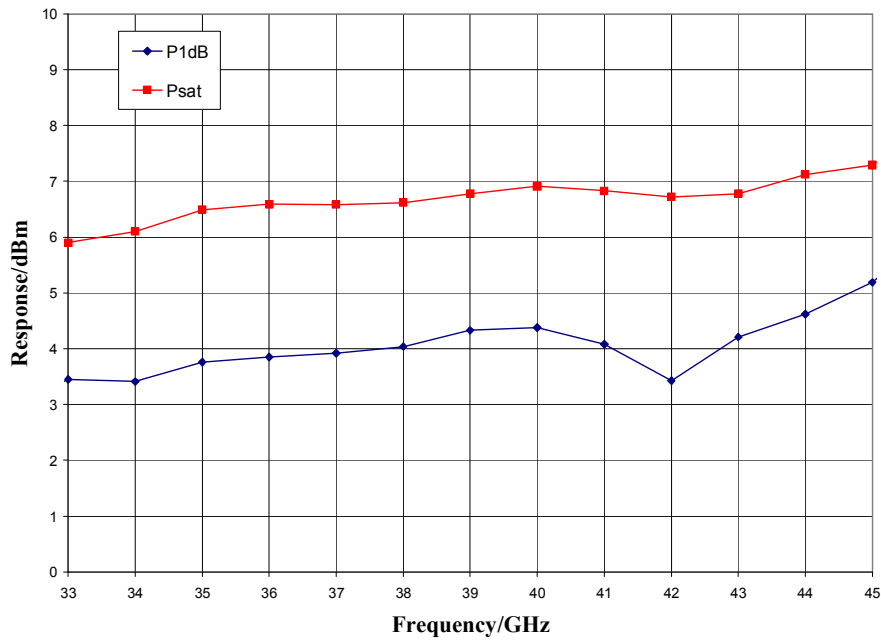

Output IP3 vs. Temperature, $V_{dd} = 2.0\text{ V}$, $V_{gg} = 2.0\text{ V}$

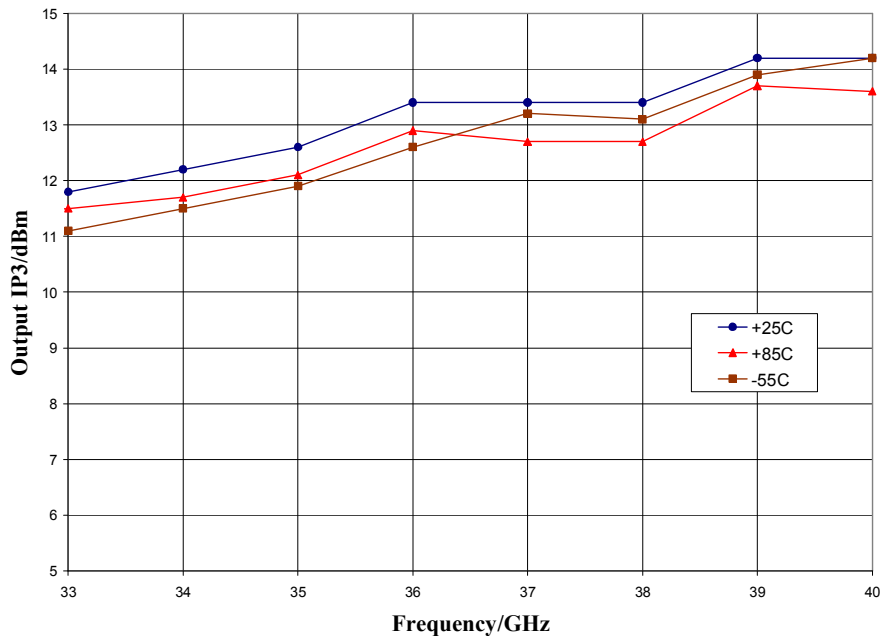

ver 1.1 1114

Mechanical Information

Die Outline (all dimensions in microns)

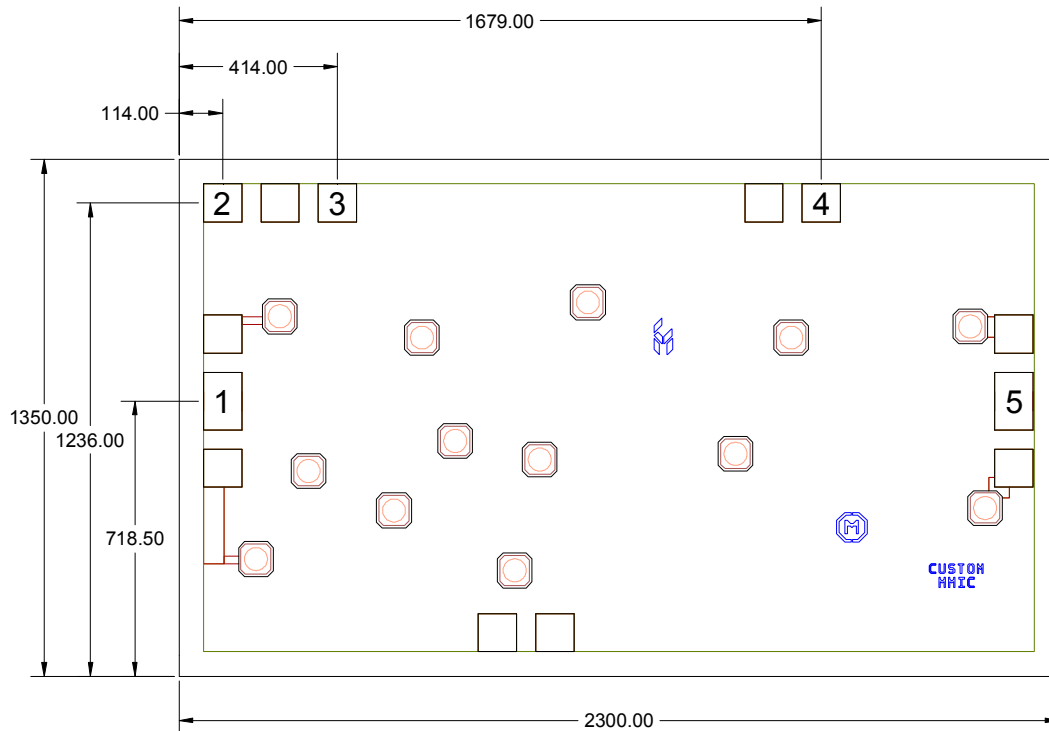

Notes:



1. No connection required for unlabeled pads
2. Backside is RF and DC ground
3. Backside and bond pad metal: Gold
4. Die is 85 microns thick
5. DC bond pads are 100 microns square

Pad Description

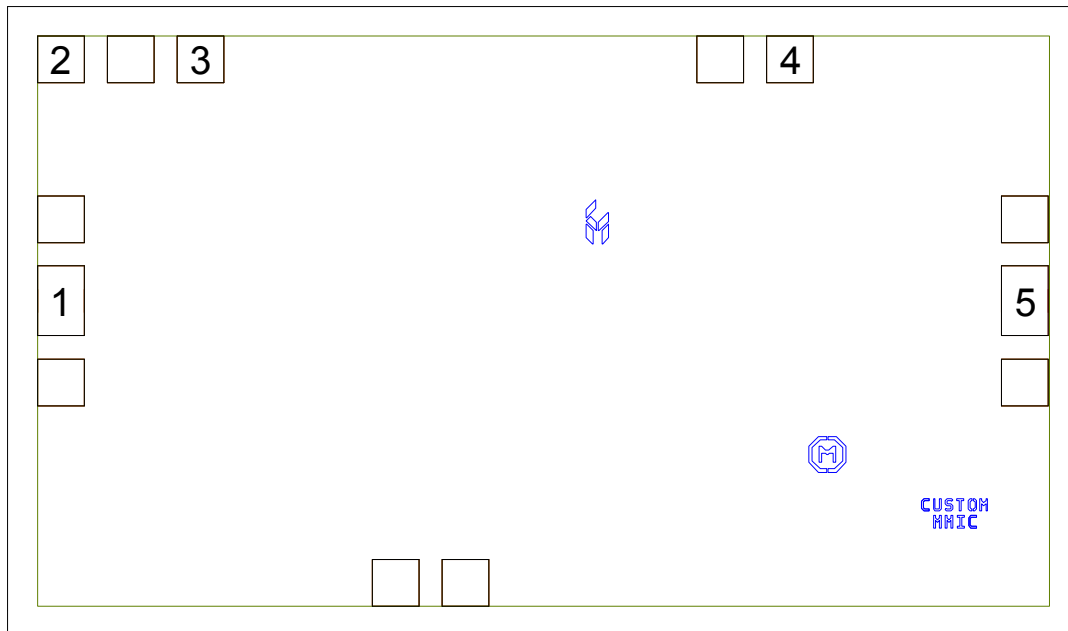
Pad Diagram

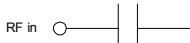
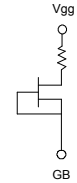
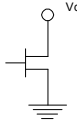

Functional Description

Pad	Function	Description	Schematic
1	RF in	DC blocked and 50 ohm matched	
2	GB	Connect to DC ground	
3	Vgg	Power supply voltage Decoupling and bypass caps required	
4	Vdd	Power supply voltage Decoupling and bypass caps required	
5	RF out	DC blocked and 50 ohm matched	
Backside	Ground	Connect to RF / DC ground	

ver 1.1 1114

Applications Information

Assembly Guidelines

The backside of the CMD190 is RF ground. Die attach should be accomplished with electrically and thermally conductive epoxy only. Eutectic attach is not recommended. Standard assembly procedures should be followed for high frequency devices. The top surface of the semiconductor should be made planar to the adjacent RF transmission lines, and the RF decoupling capacitors placed in close proximity to the DC connections on chip.

RF connections should be made as short as possible to reduce the inductive effect of the bond wire. Use of a 0.8 mil thermosonic wedge bonding is highly recommended as the loop height will be minimized. The RF input and output require a double bond wire as shown.

The semiconductor is 85 um thick and should be handled by the sides of the die or with a custom collet. Do not make contact directly with the die surface as this will damage the monolithic circuitry. Handle with care.

Assembly Diagram

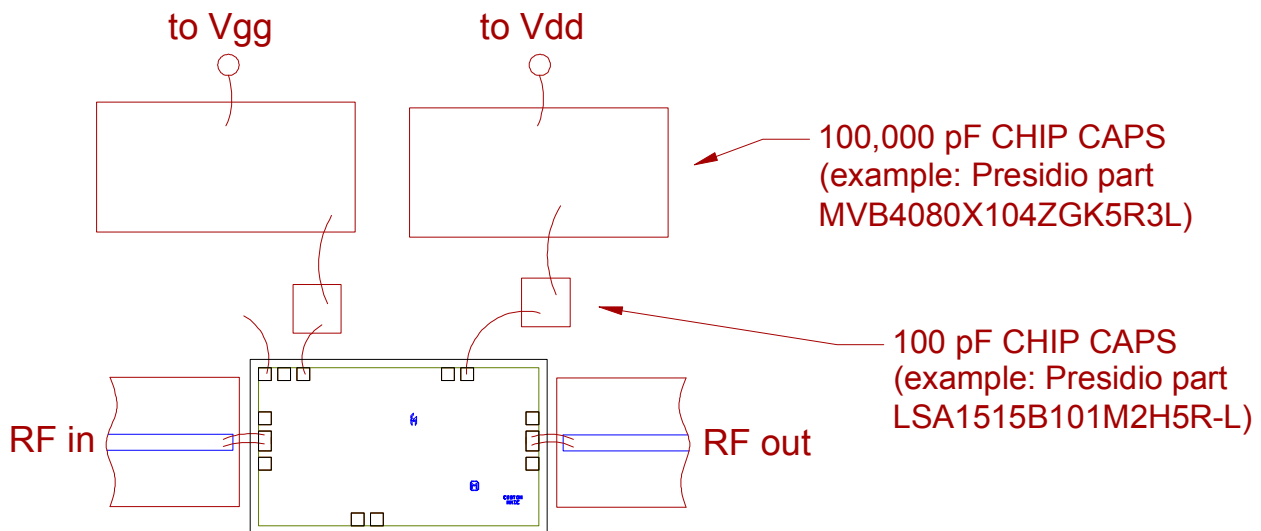

GaAs MMIC devices are susceptible to damage from Electrostatic Discharge. Proper precautions should be observed during handling, assembly and test.

Applications Information

Biasing and Operation

The CMD190 is biased with a positive drain supply and positive gate supply. Performance is optimized when the drain and gate voltage are set to +2.0 V.

Turn ON procedure:

1. Apply drain voltage V_{dd} and set to +2 V
2. Apply gate voltage V_{gg} and set to +2 V

Turn OFF procedure:

1. Turn off gate voltage V_{gg}
2. Turn off drain voltage V_{dd}

RF power can be applied at any time.

X-ON Electronics

Largest Supplier of Electrical and Electronic Components

Click to view similar products for [RF Amplifier](#) category:

Click to view products by [Qorvo](#) manufacturer:

Other Similar products are found below :

[A82-1](#) [BGA622H6820XTSA1](#) [BGA 728L7 E6327](#) [BGB719N7ESDE6327XTMA1](#) [HMC397-SX](#) [HMC405](#) [HMC561-SX](#) [HMC8120-SX](#)
[HMC8121-SX](#) [HMC-ALH382-SX](#) [HMC-ALH476-SX](#) [SE2433T-R](#) [SMA3101-TL-E](#) [SMA39](#) [A66-1](#) [A66-3](#) [A67-1](#) [LX5535LQ](#) [LX5540LL](#)
[MAAM02350](#) [HMC3653LP3BETR](#) [HMC549MS8GETR](#) [HMC-ALH435-SX](#) [SMA101](#) [SMA32](#) [SMA411](#) [SMA531](#) [SST12LP17E-XX8E](#)
[SST12LP19E-QX6E](#) [WPM0510A](#) [HMC5929LS6TR](#) [HMC5879LS7TR](#) [HMC1126](#) [HMC1087F10](#) [HMC1086](#) [HMC1016](#) [SMA1212](#)
[MAX2689EWS+T](#) [MAAMSS0041TR](#) [MAAM37000-A1G](#) [LTC6430AIUF-15#PBF](#) [CHA5115-QDG](#) [SMA70-2](#) [SMA4011](#) [A231](#) [HMC-](#)
[AUH232](#) [LX5511LQ](#) [LX5511LQ-TR](#) [HMC7441-SX](#) [HMC-ALH310](#)