

Features

- ▶ Ultra low noise figure
- ▶ High gain broadband performance
- ▶ Single supply voltage: +3.0 V @ 63 mA
- ▶ Small die size

Description

The CMD264 is a broadband MMIC low noise amplifier ideally suited for EW and communications systems where small size and low power consumption are needed. The broadband device delivers greater than 25 dB of gain with a corresponding output 1 dB compression point of +10 dBm and a noise figure of 1.6 dB. The CMD264 is a 50 ohm matched design eliminating the need for external DC blocks and RF port matching. The CMD264 amplifier is the perfect alternative to costly hybrid amplifiers.

Functional Block Diagram

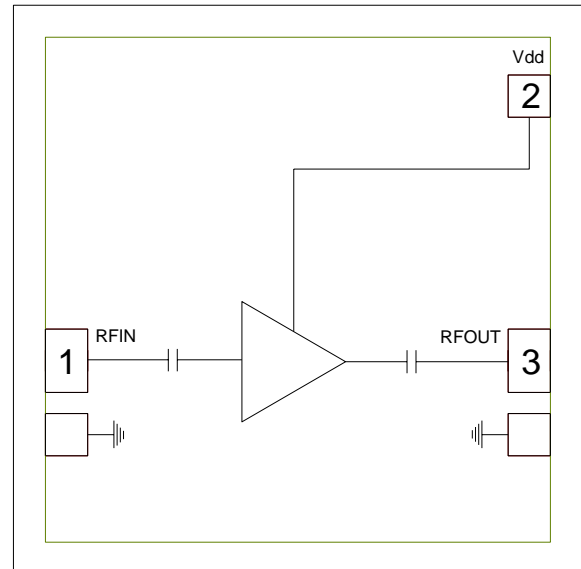

Electrical Performance – $V_{dd} = 3.0\text{ V}$, $T_A = 25\text{ }^\circ\text{C}$

Parameter	Min	Typ	Max	Units
Frequency Range	6 – 18			GHz
Gain		26		dB
Noise Figure		1.6		dB
Input Return Loss		10		dB
Output Return Loss		14		dB
Output P1dB		11		dBm
Supply Current		63		mA

Specifications

Absolute Maximum Ratings

Parameter	Rating
Drain Voltage, V _{dd}	5.0 V
RF Input Power	+20 dBm
Channel Temperature, T _{ch}	150 °C
Power Dissipation, P _{diss}	540 mW
Thermal Resistance, Θ_{JC}	120 °C/W
Operating Temperature	-55 to 85 °C
Storage Temperature	-55 to 150 °C
ESD Sensitivity (HBM)	Class 1A

Operation of this device outside the maximum ratings may cause permanent damage.

Recommended Operating Conditions

Parameter	Min	Typ	Max	Units
V _{dd}	2.0	3.0	4.5	V
I _{dd}		63		mA

Electrical performance is measured at specific test conditions. Electrical specifications are not guaranteed over all recommended operating conditions.

Electrical Specifications – V_{dd} = 3.0 V, T_A = 25 °C

Parameter	Min	Typ	Max	Min	Typ	Max	Units
Frequency Range	6 – 12			12 – 18			GHz
Gain	25	29	33	22	27	31	dB
Noise Figure		2.0	2.9		1.6	2.3	dB
Input Return Loss		15			10		dB
Output Return Loss		18			20		dB
Output P _{1dB}		13			13		dBm
Output IP ₃		27			25		dBm
Supply Current	44	63	82	44	63	82	mA
Gain Temperature Coefficient		0.015			0.015		dB/°C
Noise Figure Temperature Coefficient		0.008			0.008		dB/°C

ver 1.0 0517

Typical Performance

Broadband Performance, $V_{dd} = 3.0\text{ V}$, $I_{dd} = 63\text{ mA}$, $T_A = 25\text{ }^\circ\text{C}$

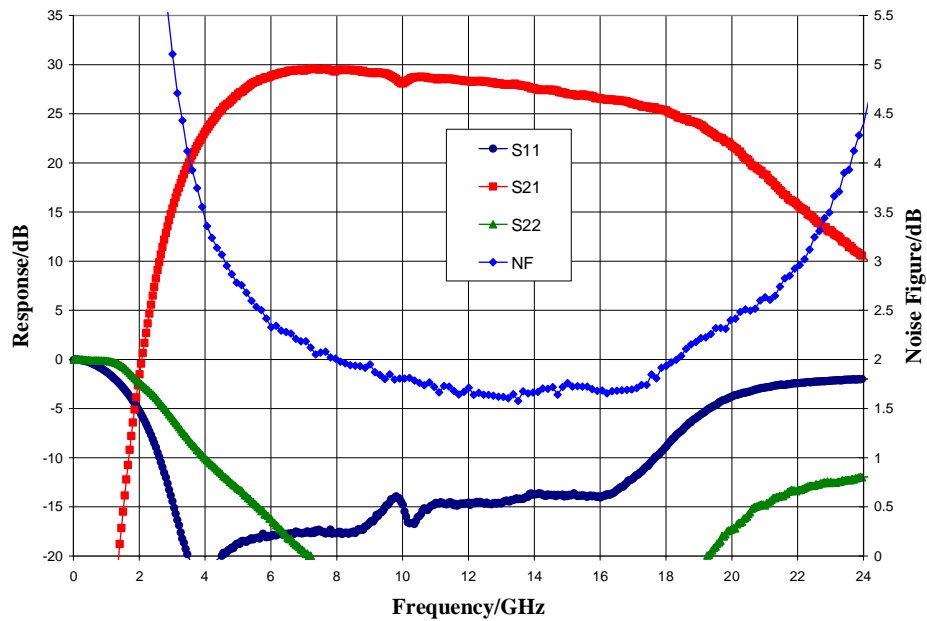

Narrow-band Performance, $V_{dd} = 3.0\text{ V}$, $I_{dd} = 63\text{ mA}$, $T_A = 25\text{ }^\circ\text{C}$

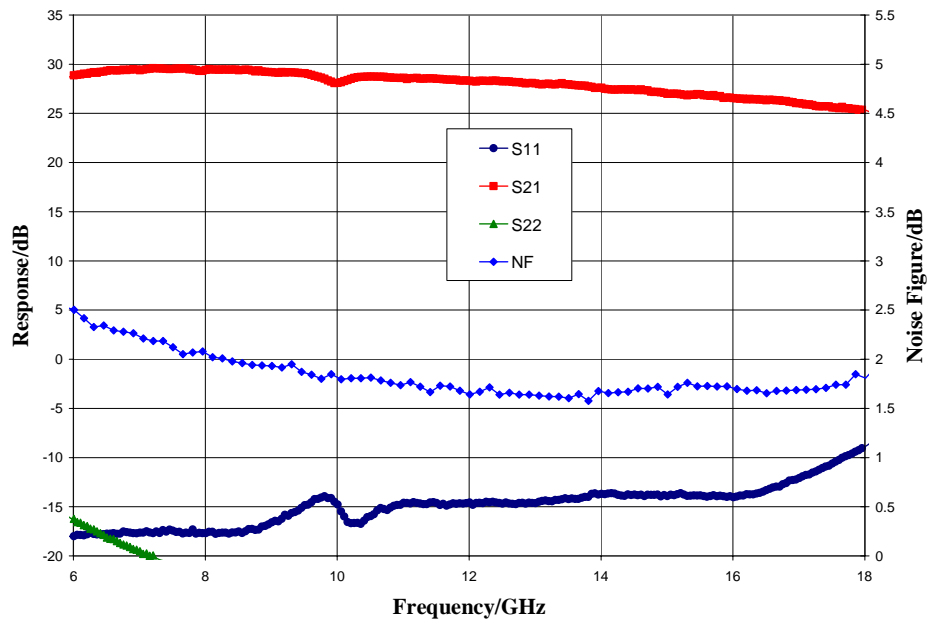

ver 1.0 0517

Typical Performance

Gain vs. Temperature, $V_{dd} = 3.0\text{ V}$

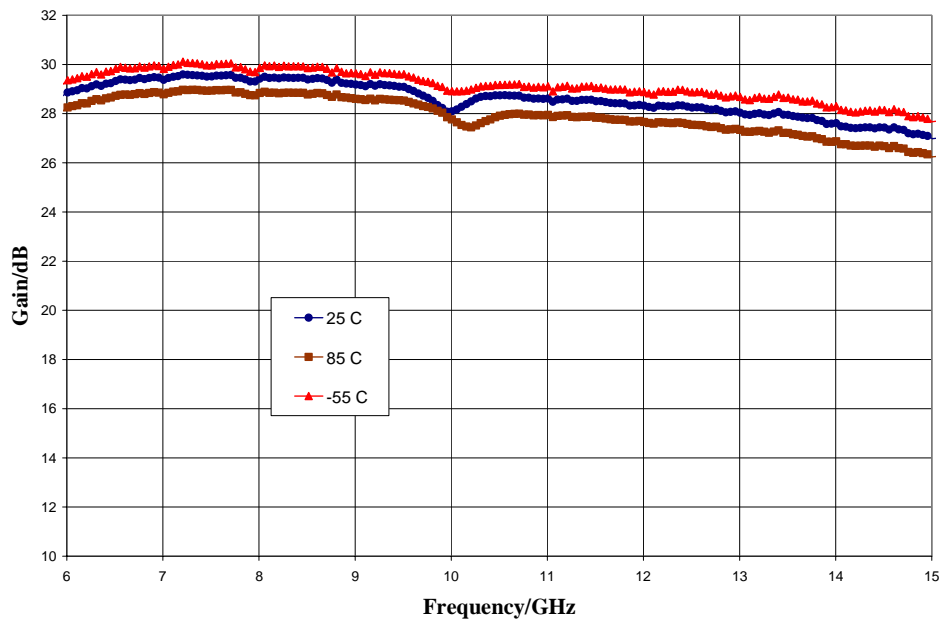

Noise Figure vs. Temperature, $V_{dd} = 3.0\text{ V}$

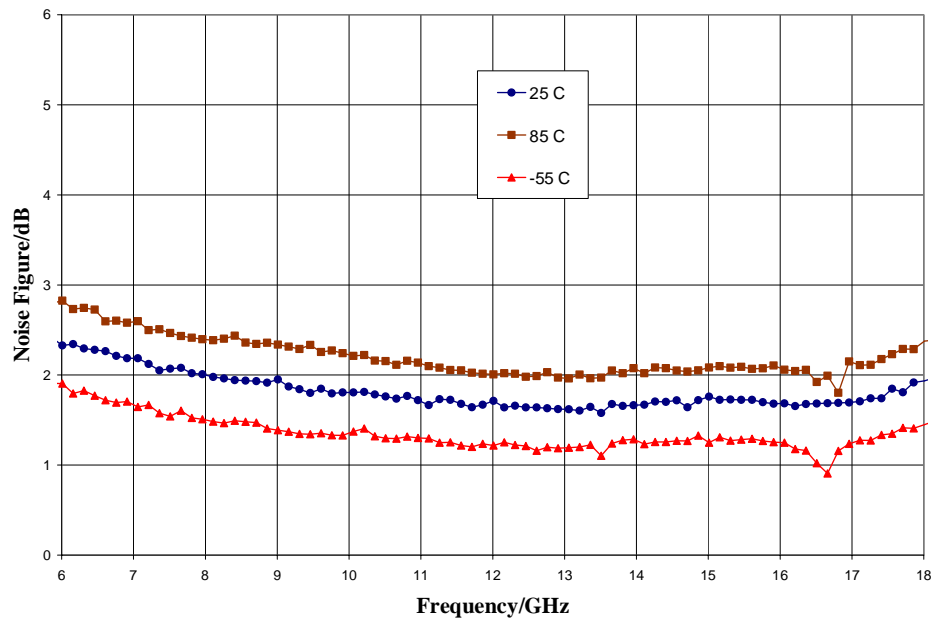

ver 1.0 0517

Typical Performance

Output Power, $V_{dd} = 3.0\text{ V}$, $I_{dd} = 63\text{ mA}$, $T_A = 25\text{ }^\circ\text{C}$

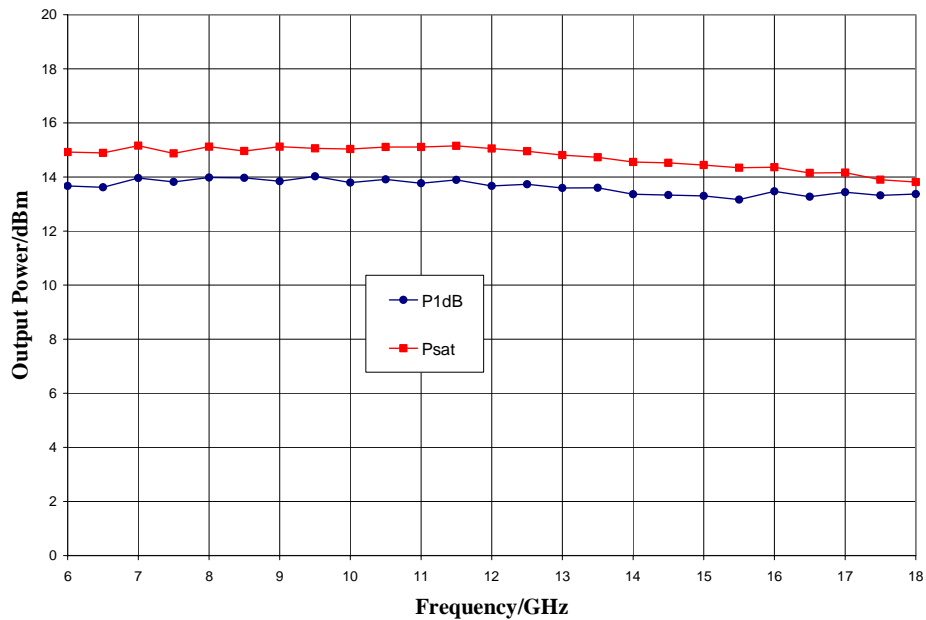

Output P1dB vs. Temperature, $V_{dd} = 3.0\text{ V}$, $I_{dd} = 63\text{ mA}$

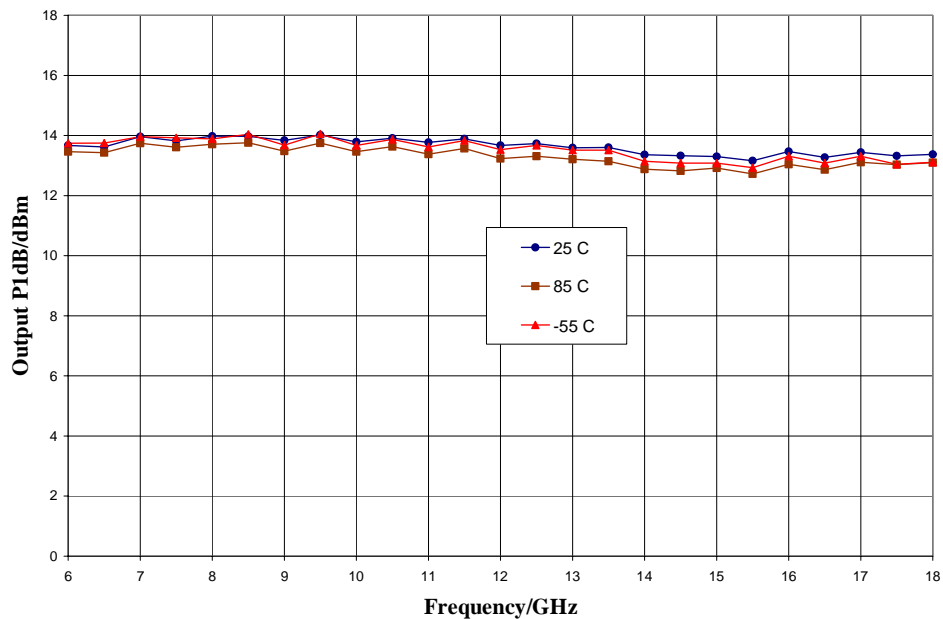

ver 1.0 0517

Typical Performance

Output IP3 vs. Temperature, $V_{dd} = 3.0\text{ V}$, $I_{dd} = 63\text{ mA}$

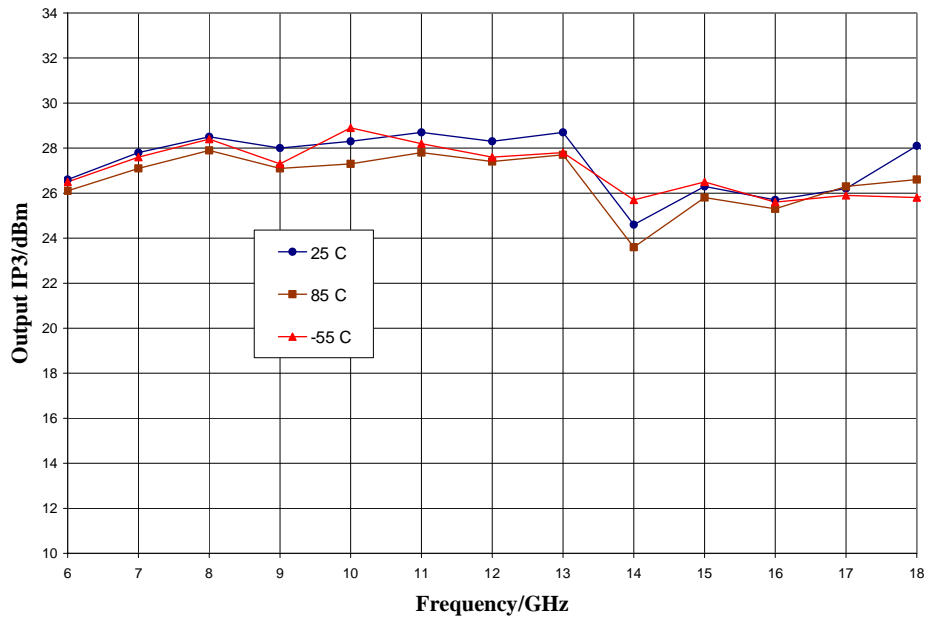

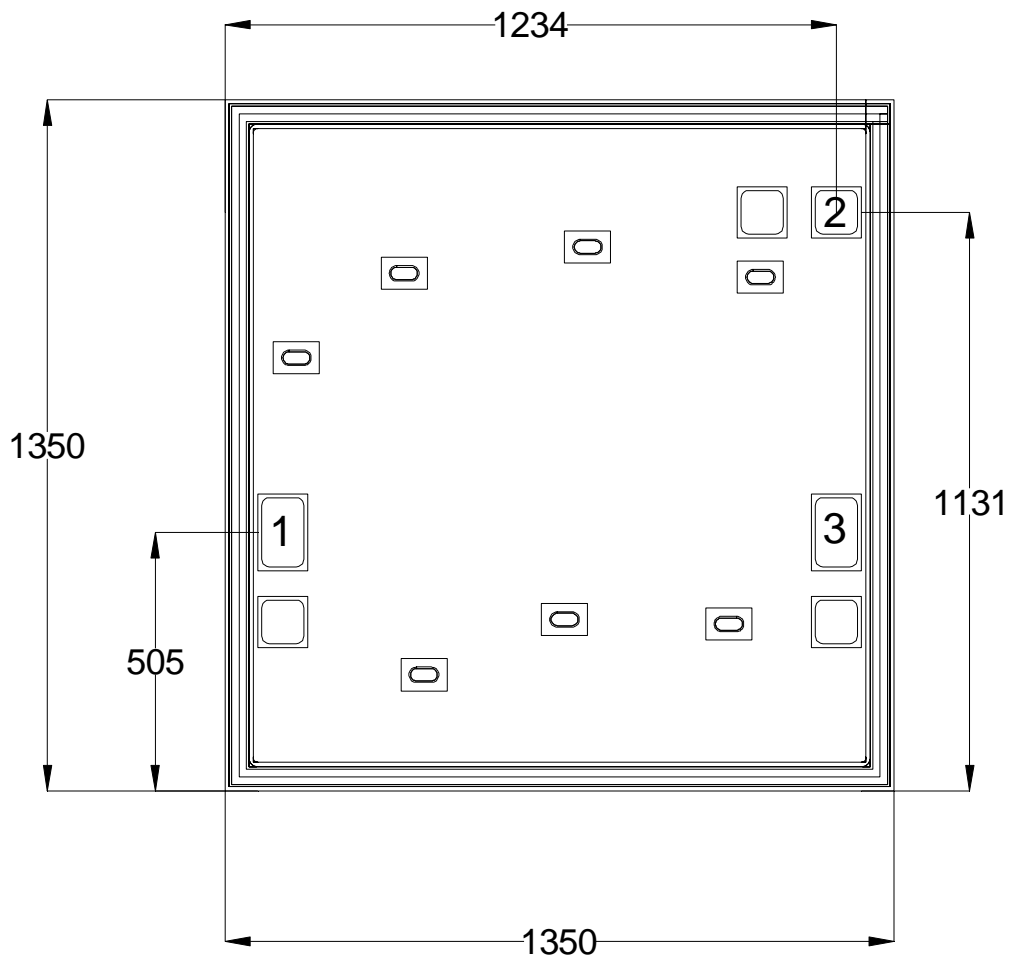
Mechanical Information**Die Outline (all dimensions in microns)****Notes:**



1. No connection required for unlabeled pads
2. Backside is RF and DC ground
3. Backside and bond pad metal: Gold
4. Die is 100 microns thick
5. DC bond pad (2) is 100 microns square
6. RF bond pads (1, 3) are 100 x 150 microns

Pad Description

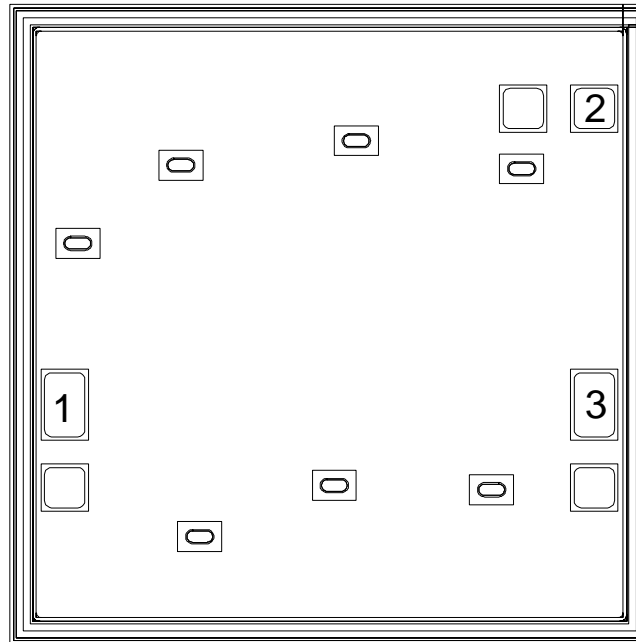
Pad Diagram

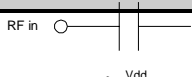
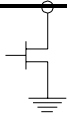
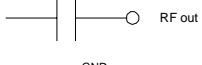

Functional Description

Pad	Function	Description	Schematic
1	RF in	DC blocked and 50 ohm matched	
2	Vdd	Power supply voltage Decoupling and bypass caps required	
3	RF out	DC blocked and 50 ohm matched	
Backside	Ground	Connect to RF / DC ground	

Applications Information

Assembly Guidelines

The backside of the CMD264 is RF ground. Die attach should be accomplished with electrically and thermally conductive epoxy only. Eutectic attach is not recommended. Standard assembly procedures should be followed for high frequency devices. The top surface of the semiconductor should be made planar to the adjacent RF transmission lines, and the RF decoupling capacitors placed in close proximity to the DC connections on chip.

RF connections should be made as short as possible to reduce the inductive effect of the bond wire. Use of a 0.8 mil thermosonic wedge bonding is highly recommended as the loop height will be minimized. The RF input and output require a double bond wire as shown.

The semiconductor is 100um thick and should be handled by the sides of the die or with a custom collet. Do not make contact directly with the die surface as this will damage the monolithic circuitry. Handle with care.

Assembly Diagram

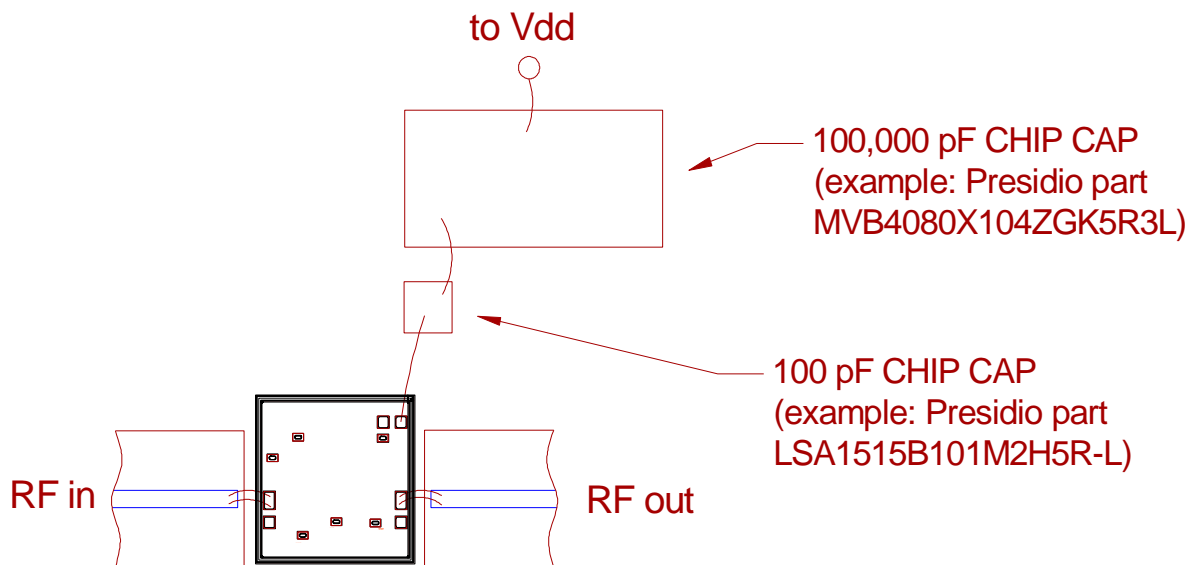

GaAs MMIC devices are susceptible to damage from Electrostatic Discharge. Proper precautions should be observed during handling, assembly and test.

ver 1.0 0517

*Applications Information***Biasing and Operation**

The CMD264 is biased with a positive drain supply. Performance is optimized when the drain voltage is set to +3.0 V, though it may be set to a minimum of +2.0 V and a maximum of +4.5 V.

Turn ON procedure:

1. Apply drain voltage V_{dd} and set to +3 V

Turn OFF procedure:

1. Turn off drain voltage V_{dd}

RF power can be applied at any time.

X-ON Electronics

Largest Supplier of Electrical and Electronic Components

Click to view similar products for [RF Amplifier](#) category:

Click to view products by [Qorvo](#) manufacturer:

Other Similar products are found below :

[A82-1](#) [BGA622H6820XTSA1](#) [BGA 728L7 E6327](#) [BGB719N7ESDE6327XTMA1](#) [HMC397-SX](#) [HMC405](#) [HMC561-SX](#) [HMC8120-SX](#)
[HMC8121-SX](#) [HMC-ALH382-SX](#) [HMC-ALH476-SX](#) [SE2433T-R](#) [SMA3101-TL-E](#) [SMA39](#) [A66-1](#) [A66-3](#) [A67-1](#) [LX5535LQ](#) [LX5540LL](#)
[MAAM02350](#) [HMC3653LP3BETR](#) [HMC549MS8GETR](#) [HMC-ALH435-SX](#) [SMA101](#) [SMA32](#) [SMA411](#) [SMA531](#) [SST12LP19E-QX6E](#)
[WPM0510A](#) [HMC5929LS6TR](#) [HMC5879LS7TR](#) [HMC1126](#) [HMC1087F10](#) [HMC1086](#) [HMC1016](#) [SMA1212](#) [MAX2689EWS+T](#)
[MAAMSS0041TR](#) [MAAM37000-A1G](#) [LTC6430AIUF-15#PBF](#) [CHA5115-QDG](#) [SMA70-2](#) [SMA4011](#) [A231](#) [HMC-AUH232](#) [LX5511LQ](#)
[LX5511LQ-TR](#) [HMC7441-SX](#) [HMC-ALH310](#) [XD1001-BD-000V](#)