

Applications

- Wireless Infrastructure
- CATV / SATV / MoCA
- Point to Point
- Defense & Aerospace
- Test & Measurement Equipment
- General Purpose Wireless

Product Features

- DC – 4 GHz
- +24 dBm P1dB at 1 GHz
- +40 dBm OIP3 at 1 GHz
- 15 dB Gain at 1 GHz
- 4.6 dB Noise Figure
- Internally matched to 50 Ω
- Lead-free / green / RoHS-Compliant SOT-89 Package

General Description

The ECG008B-G is a general-purpose buffer amplifier that offers high dynamic range in a low-cost surface-mount package. At 1000 MHz, the ECG008B-G typically provides 15 dB of gain, +40 dBm Output IP3, and +24 dBm P1dB.

The ECG008B-G consists of Darlington pair amplifiers using the high reliability InGaP/GaAs HBT process technology and only requires DC-blocking capacitors, a bias resistor, and an inductive RF choke for operation. The device is ideal for wireless applications and is available in a lead-free/green/RoHS-compliant SOT-89 package. All devices are 100% RF and DC tested.

This broadband MMIC amplifier can be directly applied to various current and next generation wireless technologies. In addition, the ECG008B-G will satisfy general amplification requirements in the DC to 4 GHz frequency range such as CATV and mobile wireless.



SOT-89 Package Style

Functional Block Diagram

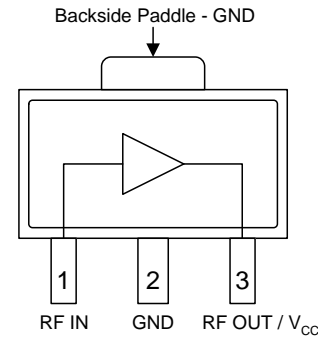

Pin Configuration

Pin No.	Label
1	RF IN
2	GND
3	RF OUT / V _{CC}
Backside Paddle	GND

Ordering Information

Part No.	Description
ECG008B-G	InGaP HBT Gain Block
ECG008B-PCB	500 – 4000 MHz Evaluation Board

Standard T/R size = 1000 pieces on a 7" reel

Absolute Maximum Ratings

Parameter	Rating
Storage Temperature	-65 to +150 °C
RF Input Power (Continuous)	+15 dBm
Device Current	160 mA

Operation of this device outside the parameter ranges given above may cause permanent damage.

Recommended Operating Conditions

Parameter	Min	Typ	Max	Units
T _{CASE}	-40		+85	°C
Junction Temperature			+160	°C

Electrical specifications are measured at specified test conditions. Specifications are not guaranteed over all recommended operating conditions.

Electrical Specifications

Test conditions unless otherwise noted: V_{SUPPLY} = +9 V, R_{BIAS} = 14 Ω, Temp.=+25 °C, 50 Ω System

Parameter	Conditions	Min	Typ	Max	Units
Operational Bandwidth		DC		4000	MHz
Gain			15		dB
Output P1dB	Freq.=1000 MHz Pout=+2 dBm / Tone, Δf = 1 MHz		+24		dBm
Output IP3			+40		dBm
Noise Figure			4.6		dB
Gain		13	14.3	17.2	dB
Input Return Loss			25		dB
Output Return Loss	Freq.=2000 MHz Pout=+2 dBm / Tone, Δf = 1 MHz		14		dB
Output P1dB			+23		dBm
Output IP3		+34	+37		dBm
Noise Figure			4.8		dB
Device Voltage		+6.8	+7.3	+7.8	V
Device Current			120		mA
Output mismatch w/o spurs			10:1		VSWR
Thermal Resistance			86		°C / W

Typical Device RF Performance ⁽¹⁾

Test conditions unless otherwise noted: V_{SUPPLY} = +9 V, I_{CC} = 120 mA (typ.), R_{BIAS} = 14 Ω, Temp.=+25 °C, 50 Ω System

Parameter	Typical								Units
Frequency	100	500	900	1900	2140	2400	3500	5800	MHz
Gain	14.8	14.7	14.6	14.3	14.3	14.2	14.5	12.4	dB
Input Return Loss	25	26	28.5	28	25	23.2	15.4	6	dB
Output Return Loss	20	19	17	13	13	12	7.9	2.7	dB
Output P1dB	+24.5	+24.3	+24	+23.2	+22.8	+21.8	+17.3		dBm
Output IP3 ⁽²⁾	+41.6	+41	+40	+37	+36	+34			dBm
Noise Figure	4.9	4.7	4.6	4.7	4.9	5.2			dB

Notes:

- Gain and return loss values presented above, and in the plots of the following section, are measured at the device level. Application specific performance values will differ in accordance with external components selected for the desired frequency band of operation. P1dB, OIP3 and NF data is measured using the application circuit shown on page 4.
- Pout = +9 dBm / tone, 1 MHz tone spacing.

Typical RF Device Performance⁽¹⁾

Test conditions unless otherwise noted: $V_{SUPPLY} = +9\text{ V}$, $I_{CC} = 120\text{ mA}$ (typ.), $R_{BIAS} = 14\ \Omega$, $50\ \Omega$ System

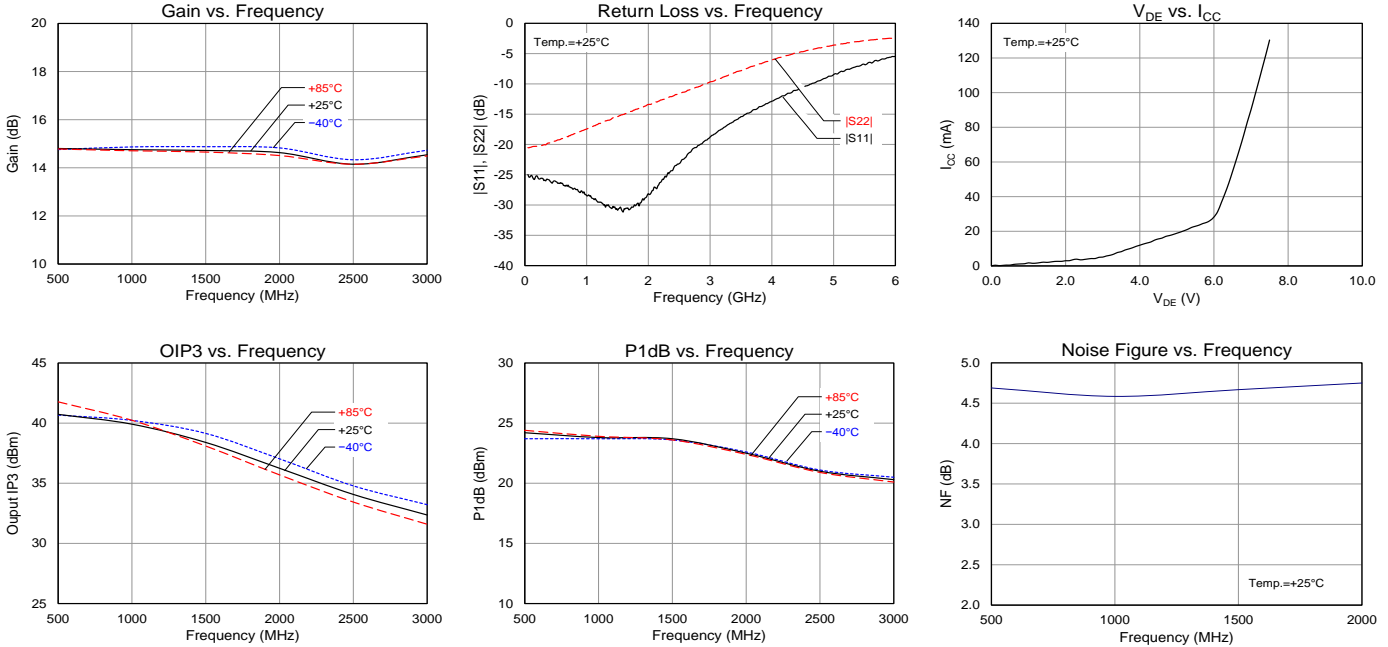

Typical Device S-Parameters

Test Conditions: $V_{DEVICE} = +7.3\text{ V}$, $I_{CC} = 120\text{ mA}$, Temp. = +25 °C, Calibrated to device leads

Freq (MHz)	S11 (dB)	S11 (ang)	S21 (dB)	S21 (ang)	S12 (dB)	S12 (ang)	S22 (dB)	S22 (ang)
50	-24.87	176.05	14.88	177.77	-18.94	-1.51	-20.41	-4.20
500	-26.14	167.68	14.71	161.26	-18.94	-5.99	-19.43	-39.76
1000	-28.46	166.94	14.60	142.99	-19.02	-11.44	-17.47	-72.27
1500	-30.86	-178.22	14.39	125.46	-18.94	-16.56	-15.40	-95.62
2000	-28.14	-144.76	14.30	108.38	-18.86	-21.00	-13.40	-116.18
2500	-23.15	-137.68	14.20	91.08	-18.64	-25.54	-11.63	-133.34
3000	-18.78	-150.37	14.30	74.41	-18.20	-29.98	-9.65	-151.20
3500	-15.39	-171.26	14.48	56.29	-17.52	-36.74	-7.83	-171.17
4000	-12.91	161.38	14.65	35.57	-16.85	-45.50	-6.06	165.56
4500	-10.59	132.87	14.51	13.60	-16.36	-56.53	-4.68	141.33
5000	-8.44	105.27	14.04	-8.75	-16.20	-68.74	-3.62	117.07
5500	-6.76	80.71	13.17	-31.25	-16.26	-81.52	-2.87	94.30
6000	-5.43	61.63	12.10	-50.89	-16.59	-93.75	-2.41	73.89

Notes:

1. Device S-parameters are available for download off of the website at: www.triquint.com

ECG008B-PCB Evaluation Board

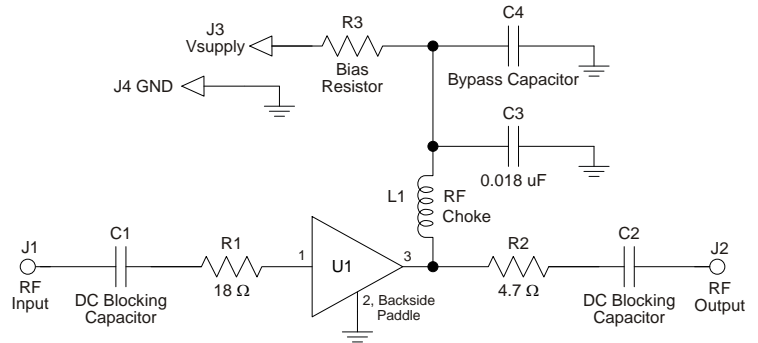
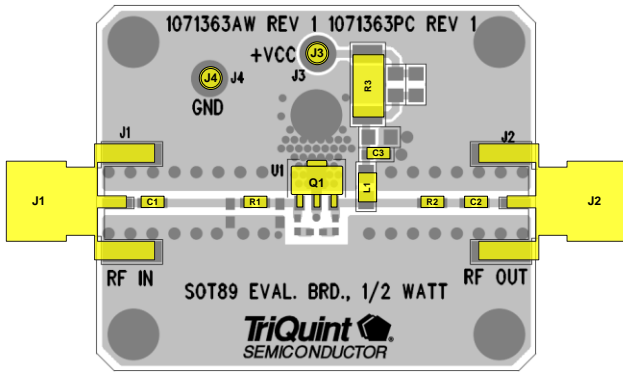

Notes:

1. See Evaluation Board PCB Information section for material and stack-up.

Bill of Material: ECG008B-PCB

Ref. Des.	Value	Description
U1	n/a	ECG008B-G
L1	39 nH	Wirewound Inductor, 0603
C1, C2	56 pF	Chip Capacitor, 0603
C3	0.018 μF	Chip Capacitor, 0603
C4	Do Not Place	
R1	18 Ω	Chip Resistor, 0603
R2	4.7 Ω	Chip Resistor, 0603
R3	14 Ω	1% Tolerance, 2010

R_{BIAS} Values for Various V_{SUPPLY}

V _{SUPPLY} (V _{CC})	9	10	12
R3 (Ω)	14	23	39
Component Size	2010	2512	2512

Component Values for Specific Frequencies

Frequency (MHz)	50	500	900	1900	2200	2500	3500
L1	820 nH	220 nH	68 nH	27 nH	22 nH	18 nH	15 nH
C1, C2, C3	.018 uF	1000 pF	100 pF	68 pF	68 pF	56 pF	39 pF

Notes:

1. R1 and R2 are shown in the circuit diagram to avoid potential instabilities. The configuration shown above assures unconditional stability. It is expected linearity parameters (OIP3 and P1dB) to degrade about 0.5 dB, while overall gain will be about 2 dB less than the performance shown on page 2 and 3. Input and output return loss is expected to improve with the use of the I/O series resistances at 2 GHz.

Application Circuit RF Performance

Test conditions unless otherwise noted: VSUPPLY = +9 V, RBIAS = 14 Ω, ICC = 120 mA (typ.), 50 Ω System

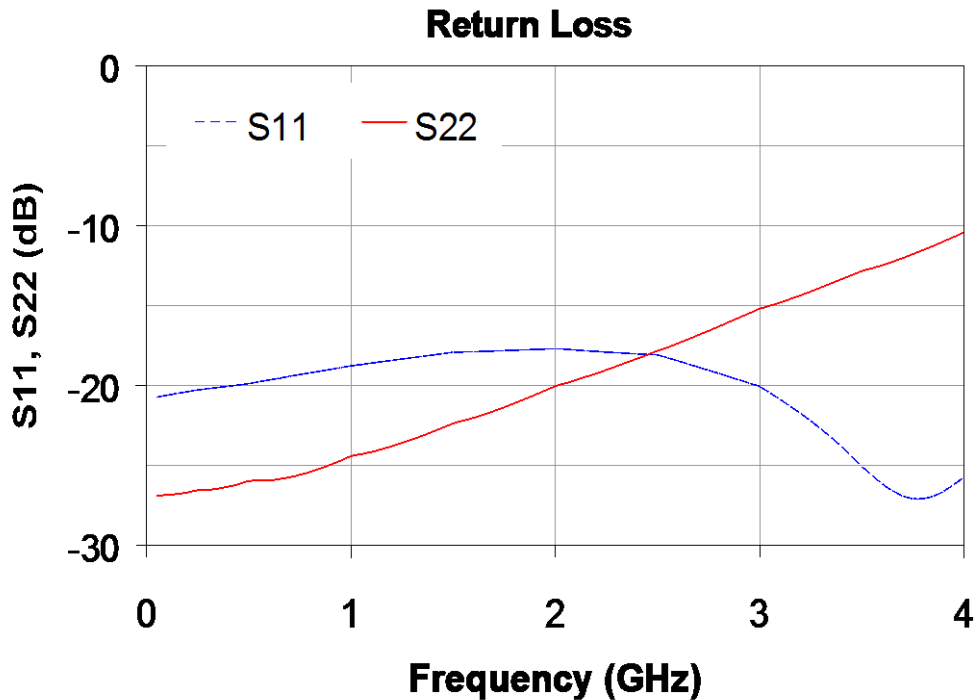
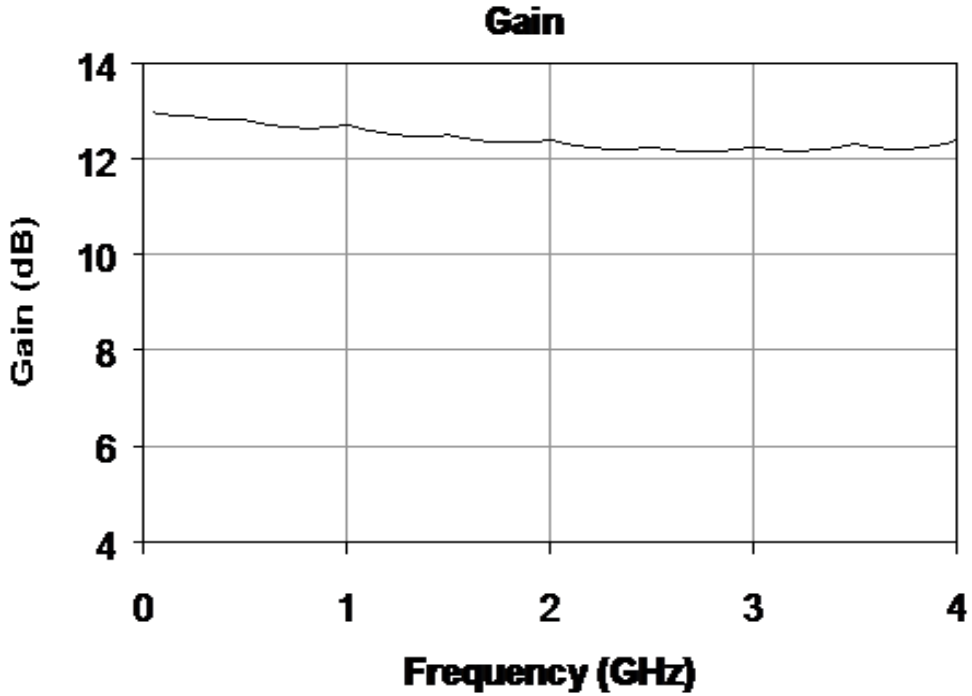

Pin Configuration and Description

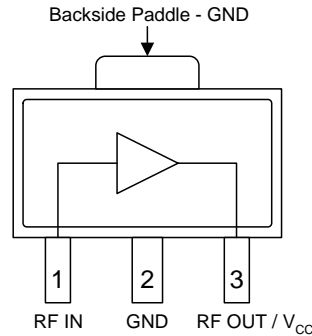

Pin No.	Label	Description
1	RF IN	RF input, matched to 50 Ω. External DC Block is required.
3	RF OUT / V _{CC}	RF output / DC supply, matched to 50 Ω. External DC Block, bias choke, and dropping resistor is required.
2, Backside Paddle	GND Paddle	RF/DC ground. Use recommended via pattern to minimize inductance and thermal resistance. See PCB Mounting Pattern for suggested footprint.

Evaluation Board PCB Information

TriQuint PCB 1069136 Material and Stack-up

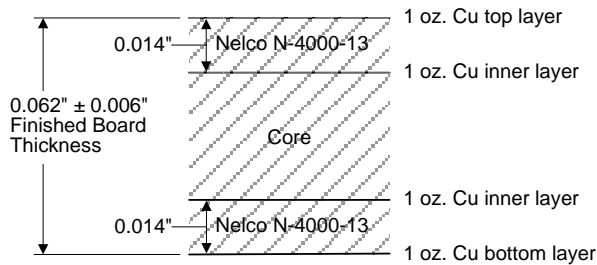

50 Ohm Line Dimensions: Width=0.028"
Spacing=0.036"

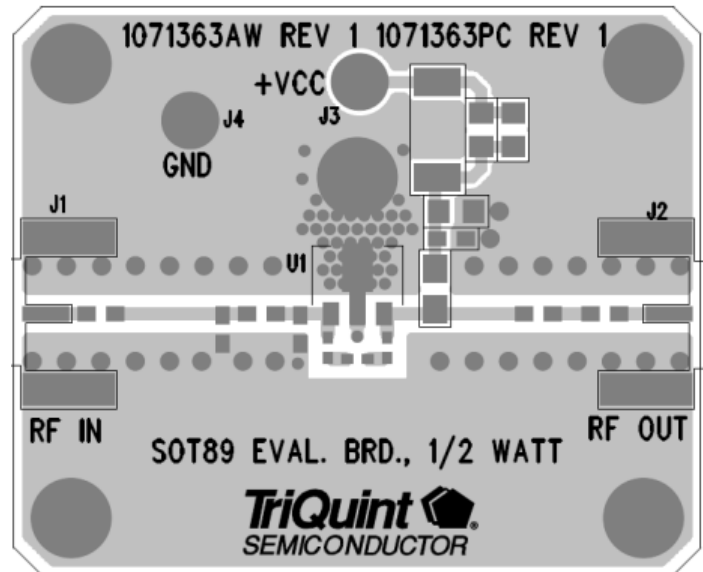

Package Marking and Dimensions

Marking: Product Identifier – E008G
Lot Code – YXXX

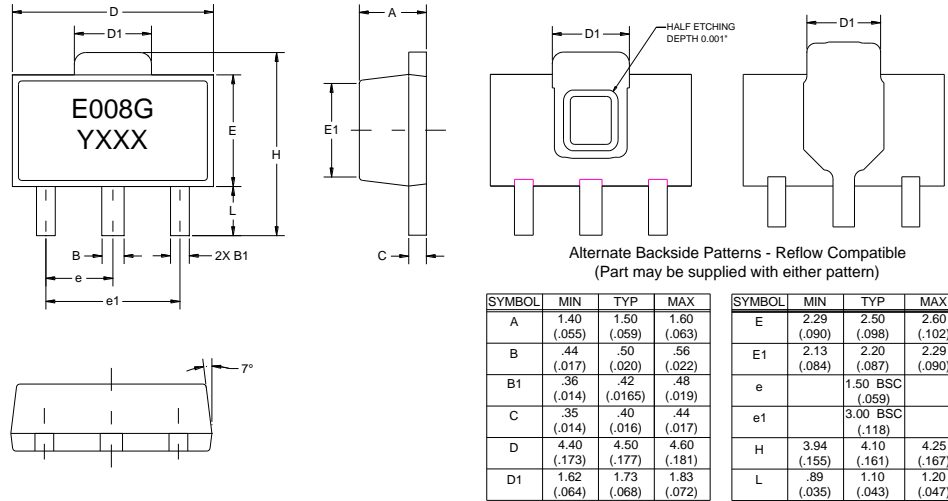

Notes:

1. All dimensions are in millimeters. Angles are in degrees.
2. Dimension and tolerance formats conform to ASME Y14.4M-1994.
3. The terminal #1 identifier and terminal numbering conform to JESD 95-1 SPP-012.
4. Contact plating: NiPdAu

PCB Mounting Pattern

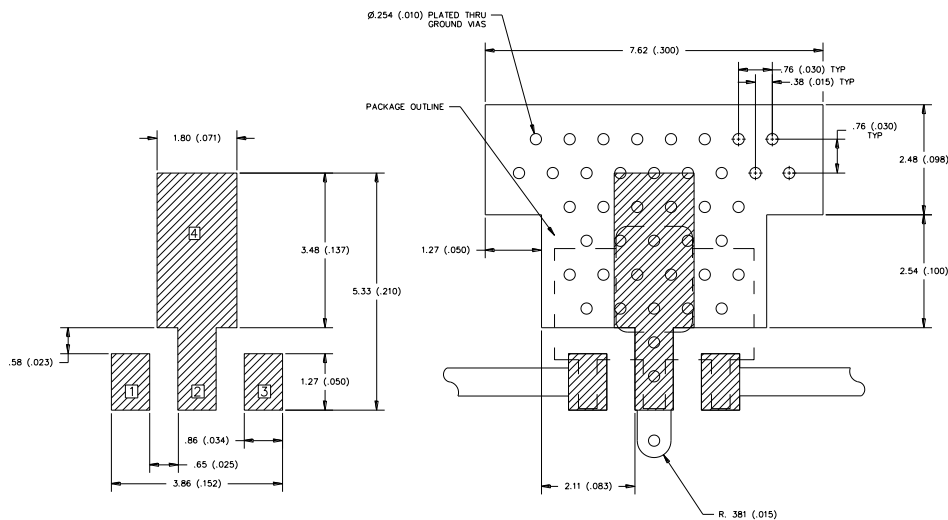

Notes:

1. All dimensions are in millimeters. Angles are in degrees.
2. Use 1 oz. copper minimum for top and bottom layer metal.
3. Vias are required under the backside paddle of this device for proper RF/DC grounding and thermal dissipation.
4. Do not remove or minimize via hole structure in the PCB. Thermal and RF grounding is critical.
5. We recommend a 0.35mm (#80/.0135") diameter bit for drilling via holes and a final plated thru diameter of 0.25 mm (0.10").
6. Ensure good package backside paddle solder attach for reliable operation and best electrical performance.

Product Compliance Information

ESD Sensitivity Ratings



Caution! ESD-Sensitive Device

ESD Rating: Class 1A
Value: ≥ 250 V to < 500 V
Test: Human Body Model (HBM)
Standard: ESDA/JEDEC Standard JS-001-2012

MSL Rating

MSL Rating: Level 3
Test: 260 °C convection reflow
Standard: JEDEC Standard IPC/JEDEC J-STD-020

Solderability

Compatible with both lead-free (260 °C maximum reflow temperature) and tin/lead (245 °C maximum reflow temperature) soldering processes.

Contact plating: NiPdAu

RoHS Compliance

This part is compliant with EU 2002/95/EC RoHS directive (Restrictions on the Use of Certain Hazardous Substances in Electrical and Electronic Equipment).

This product also has the following attributes:

- Lead Free
- Halogen Free (Chlorine, Bromine)
- Antimony Free
- TBBP-A (C₁₅H₁₂Br₄O₂) Free
- PFOS Free
- SVHC Free

Contact Information

For the latest specifications, additional product information, worldwide sales and distribution locations:

Web: www.triquint.com

Tel: 877-800-8584

Email: customer.support@qorvo.com

For information about the merger of RFMD and TriQuint as Qorvo:

Web: www.qorvo.com

For technical questions and application information:

Email: sjcapplications.engineering@qorvo.com

Important Notice

The information contained herein is believed to be reliable. TriQuint makes no warranties regarding the information contained herein. TriQuint assumes no responsibility or liability whatsoever for any of the information contained herein. TriQuint assumes no responsibility or liability whatsoever for the use of the information contained herein. The information contained herein is provided "AS IS, WHERE IS" and with all faults, and the entire risk associated with such information is entirely with the user. All information contained herein is subject to change without notice. Customers should obtain and verify the latest relevant information before placing orders for TriQuint products. The information contained herein or any use of such information does not grant, explicitly or implicitly, to any party any patent rights, licenses, or any other intellectual property rights, whether with regard to such information itself or anything described by such information.

TriQuint products are not warranted or authorized for use as critical components in medical, life-saving, or life-sustaining applications, or other applications where a failure would reasonably be expected to cause severe personal injury or death.

X-ON Electronics

Largest Supplier of Electrical and Electronic Components

Click to view similar products for [RF Development Tools](#) category:

Click to view products by [Qorvo](#) manufacturer:

Other Similar products are found below :

[MAAM-011117](#) [MAAP-015036-DIEEV2](#) [EV1HMC1113LP5](#) [EV1HMC6146BLC5A](#) [EV1HMC637ALP5](#) [EVAL-ADG919EBZ](#) [ADL5363-EVALZ](#) [LMV228SDEVAL](#) [SKYA21001-EVB](#) [SMP1331-085-EVB](#) [EV1HMC618ALP3](#) [EVAL01-HMC1041LC4](#) [MAAL-011111-000SMB](#)
[MAAM-009633-001SMB](#) [MASW-000936-001SMB](#) [107712-HMC369LP3](#) [107780-HMC322ALP4](#) [SP000416870](#) [EV1HMC470ALP3](#)
[EV1HMC520ALC4](#) [EV1HMC244AG16](#) [MAX2614EVKIT#](#) [124694-HMC742ALP5](#) [SC20ASATEA-8GB-STD](#) [MAX2837EVKIT+](#)
[MAX2612EVKIT#](#) [MAX2692EVKIT#](#) [EV1HMC629ALP4E](#) [SKY12343-364LF-EVB](#) [108703-HMC452QS16G](#) [EV1HMC863ALC4](#)
[EV1HMC427ALP3E](#) [119197-HMC658LP2](#) [EV1HMC647ALP6](#) [ADL5725-EVALZ](#) [MAX2371EVKIT#](#) [106815-HMC441LM1](#)
[EV1HMC1018ALP4](#) [UXN14M9PE](#) [MAX2016EVKIT](#) [EV1HMC939ALP4](#) [MAX2410EVKIT](#) [MAX2204EVKIT+](#) [EV1HMC8073LP3D](#)
[SIMSA868-DKL](#) [SIMSA868C-DKL](#) [SKY65806-636EK1](#) [SKY68020-11EK1](#) [SKY67159-396EK1](#) [SKY66181-11-EK1](#)