



QM14501

GPS, GLONASS, and BeiDou Low Noise Amplifier With Integrated Output SAW Filter

Product Overview

The QM14501 is a Low Noise Amplifier with an integrated SAW filter at the output. The low noise figure and high gain make the QM14501 ideal for GNSS receivers requiring high sensitivity. This module uses pHEMT process and integrates input matching and low loss, high rejection SAW filter at the output. This results in a simplified and high-performing receiver design. The QM14501 is packaged in a 3.3 mm x 2.1 mm x 1.0 mm package with low external component count required to achieve the best-in-class performance.

Functional Block Diagram

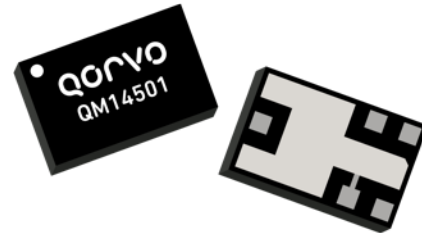
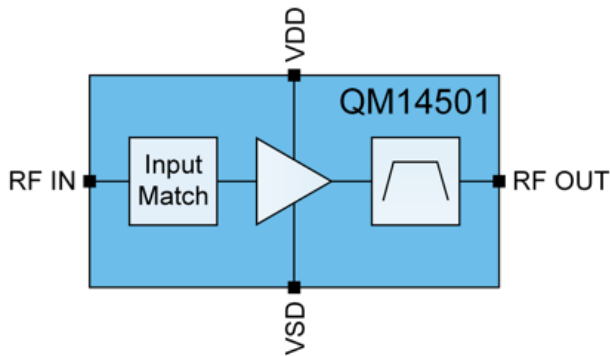

Package Style: module 3.3 mm x 2.1 mm x 1.0 mm

Key Features

- Low Noise Figure: 0.9 dB
- Gain: 13.5 dB
- High IIP3: +8 dBm
- Current Tunability Via Single Resistor
- Operating frequencies: 1.55 – 1.61 GHz
- Small package: 3.3 mm x 2.1 mm x 1.0 mm (nominal)

Applications

- Cellular and Non-Cellular GNSS receivers (GPS, GLONASS, and BeiDou platforms)

Ordering Information

Part Number	Description
QM14501SB	5 Piece Sample Bag
QM14501SR	100 Piece Reel
QM14501TR13-5K	5000 Piece 13" Reel
QM14501PCK401	Fully Assembled Evaluation Board

GPS, GLONASS, and BeiDou Low Noise Amplifier With Integrated Output SAW Filter

Absolute Maximum Ratings

Parameter	Rating	Unit
V _{DD}	3.6	V
Logic – SD	3.6	V
Supply Current I _{DD}	20	mA
RF Input Power	+15	dBm
Operating Temperature	-30 to +85	°C
Storage Temperature	-65 to +150	°C
ESD (HBM)	TBD	V

Exceeding any one or a combination of the Absolute Maximum Rating conditions may cause permanent damage to the device. Extended application of Absolute Maximum Rating conditions to the device may reduce device reliability. Specified typical performance or functional operation of the device under Absolute Maximum Rating conditions is not implied.

Nominal Operating Parameters

Parameter	Specification			Unit	Condition
	Min.	Typ.	Max.		
General Performance					
V _{DD} Supply Voltage	1.5		3.3	V	
V _{DD} Supply Current, Gain Mode		8		mA	
V _{DD} Supply Current, Low Current Mode		4.5		mA	
V _{DD} Supply Current, Shutdown Mode		0.1		uA	
SD – Control Logic Voltage HIGH	1.0		V _{DD}	V	
SD – Control Logic Voltage LOW	0		0.4	V	
SD Control Logic Current		760		uA	

GPS, GLONASS, and BeiDou Low Noise Amplifier With Integrated Output SAW Filter

Electrical Specifications – GPS Band (1575.42 MHz ± 12 MHz)

Parameter	Specification			Unit	Condition
	Min.	Typ.	Max.		
					Nominal conditions unless otherwise stated (T = 25 °C, 50 Ω) V _{DD} = 2.8 V, VSD = 2.8 V, R2 = 3 kΩ
Gain Mode					
Operating Frequency Range	1563.42		1587.42	MHz	
V _{DD} Supply Current		8.8		mA	
Gain		13.7		dB	
Noise Figure		0.9		dB	
Input Return Loss		7		dB	
Output Return Loss		24		dB	
Reverse Isolation		23		dB	
Input 1dB Compression Point		-2		dBm	
Input Third Order Intercept Point		9		dBm	F1 – F2 = 1 MHz, PF1 & PF2 = -30 dBm
Cell Band Rejection (Relative to 1575 GHz at 827.5 Hz)		54		dBc	
PCS Band Rejection (Relative to 1575 GHz at 1885 MHz)		45		dBc	
Stability Factor k	1				20 MHz to 10 GHz
Low Current Mode					Nominal conditions unless otherwise stated (T = 25 °C, 50 Ω) V _{DD} = 2.8 V, VSD = 1.67 V, R2 = 3 kΩ
V _{DD} Supply Current		4.9		mA	
Gain		12.8		dB	
Noise Figure		1.0		dB	
Input Return Loss		6		dB	
Output Return Loss		25		dB	
Reverse Isolation		22		dB	
Input 1dB Compression Point		0		dBm	
Input Third Order Intercept Point		6		dBm	F1 – F2 = 1 MHz, PF1 & PF2 = -30 dBm
Cell Band Rejection (Relative to 1575 GHz at 827.5 Hz)		55		dBc	
PCS Band Rejection (Relative to 1575 GHz at 1885 MHz)		44		dBc	
Stability Factor k	1				20 MHz to 10 GHz
Low Voltages	V _{DD} = 2 V	V _{DD} = 1.5 V	V _{DD} = 1 V		Nominal conditions unless otherwise stated (T = 25 °C, 50 Ω) VSD = V _{DD} , R2 = 1.5 kΩ
V _{DD} Supply Current	10.5	7.3	4	mA	
Gain	14	13.5	11.5	dB	
Noise Figure	0.85	0.95	1.1	dB	
Input 1dB Compression Point	-2	-4	-6	dB	
Input Third Order Intercept Point	10	7.5	3	dB	

GPS, GLONASS, and BeiDou Low Noise Amplifier With Integrated Output SAW Filter

Electrical Specifications: GLONASS (1598 MHz – 1605 MHz)

Parameter	Specification			Unit	Condition
	Min.	Typ.	Max.		
					Nominal conditions unless otherwise stated (T = 25 °C, 50 Ω) V _{DD} = 2.8 V, VSD = 2.8 V, R2 = 3 kΩ
Gain Mode					
Operating Frequency Range	1598		1606	MHz	
V _{DD} Supply Current		8.8		mA	
Gain		13.1		dB	
Noise Figure		0.9		dB	
Input Return Loss		7		dB	
Output Return Loss		21		dB	
Reverse Isolation		24		dB	
Input 1dB Compression Point		-1		dBm	
Input Third Order Intercept Point		8		dBm	F1 – F2 = 1 MHz, PF1 & PF2 = -30 dBm
Cell Band Rejection (Relative to 1575 GHz at 827.5 Hz)		54		dBc	
PCS Band Rejection (Relative to 1575 GHz at 1885 MHz)		45		dBc	
Stability Factor k	1				20 MHz to 10 GHz
Low Current Mode					Nominal conditions unless otherwise stated (T = 25 °C, 50 Ω) V _{DD} = 2.8 V, VSD = 1.67 V, R2 = 3 kΩ
V _{DD} Supply Current		4.9		mA	
Gain		12.2		dB	
Noise Figure		1.0		dB	
Input Return Loss		6		dB	
Output Return Loss		18		dB	
Reverse Isolation		23		dB	
Input 1dB Compression Point		0		dBm	
Input Third Order Intercept Point		5		dBm	F1 – F2 = 1 MHz, PF1 & PF2 = -30 dBm
Cell Band Rejection (Relative to 1575 GHz at 827.5 Hz)		55		dBc	
PCS Band Rejection (Relative to 1575 GHz at 1885 MHz)		44		dBc	
Stability Factor k	1				20 MHz to 10 GHz
Low Voltages	V _{DD} = 2 V	V _{DD} = 1.5 V	V _{DD} = 1 V		Nominal conditions unless otherwise stated (T = 25 °C, 50 Ω) VSD = V _{DD} , R2 = 1.5 kΩ
V _{DD} Supply Current	10.5	7.3	4	mA	
Gain	13.5	13	1.1	dB	
Noise Figure	0.85	0.95	1.1	dB	
Input 1dB Compression Point	-2	-4	-6	dB	
Input Third Order Intercept Point	10	7.5	3	dB	

GPS, GLONASS, and BeiDou Low Noise Amplifier With Integrated Output SAW Filter

Electrical Specifications: BeiDou (1561.098 MHz)

Parameter	Specification			Unit	Condition
	Min.	Typ.	Max.		
					Nominal conditions unless otherwise stated (T = 25 °C, 50 Ω) V _{DD} = 2.8 V, V _{SD} = 2.8 V, R ₂ = 3 kΩ
Gain Mode					
Operating Frequency Range	1559		1563	MHz	
V _{DD} Supply Current		8.8		mA	
Gain		13.1		dB	
Noise Figure		0.9		dB	
Input Return Loss		9		dB	
Output Return Loss		13		dB	
Reverse Isolation		24		dB	
Input 1dB Compression Point		-1		dBm	
Input Third Order Intercept Point		9		dBm	F1 – F2 = 1 MHz, PF1 & PF2 = -30 dBm
Cell Band Rejection (Relative to 1575 GHz at 827.5 Hz)		54		dBc	
PCS Band Rejection (Relative to 1575 GHz at 1885 MHz)		45		dBc	
Stability Factor k	1				20 MHz to 10 GHz
Low Current Mode					Nominal conditions unless otherwise stated (T = 25 °C, 50 Ω) V _{DD} = 2.8 V, V _{SD} = 1.67 V, R ₂ = 3 kΩ
V _{DD} Supply Current		4.9		mA	
Gain		12.1		dB	
Noise Figure		1.1		dB	
Input Return Loss		8		dB	
Output Return Loss		12		dB	
Reverse Isolation		23		dB	
Input 1dB Compression Point		0		dBm	
Input Third Order Intercept Point		6		dBm	F1 – F2 = 1 MHz, PF1 & PF2 = -30 dBm
Cell Band Rejection (Relative to 1575 GHz at 827.5 Hz)		55		dBc	
PCS Band Rejection (Relative to 1575 GHz at 1885 MHz)		44		dBc	
Stability Factor k	1				20 MHz to 10 GHz
Low Voltages	V _{DD} = 2 V	V _{DD} = 1.5 V	V _{DD} = 1 V		Nominal conditions unless otherwise stated (T = 25 °C, 50 Ω) V _{SD} = V _{DD} , R ₂ = 1.5 kΩ
V _{DD} Supply Current	10.5	7.3	4	mA	
Gain	13	12.5	10.5	dB	
Noise Figure	0.95	1	1.2	dB	
Input 1dB Compression Point	-2	-4	-6	dBm	
Input Third Order Intercept Point	10	7.5	3	dBm	

GPS, GLONASS, and BeiDou Low Noise Amplifier With Integrated Output SAW Filter

Pin – Out Description

Pin	Name	Description
1	RFIN	LNA input
2	GND	Ground
3	SD	Shutdown
4	GND	Ground
5	GND	Ground
6	GND	Ground
7	GND	Ground
8	RFOUT	Filter output
9	GND	Ground
10	GND	Ground
11	GND	Ground
12	V _{DD}	DC supply

Pin – Out Drawing

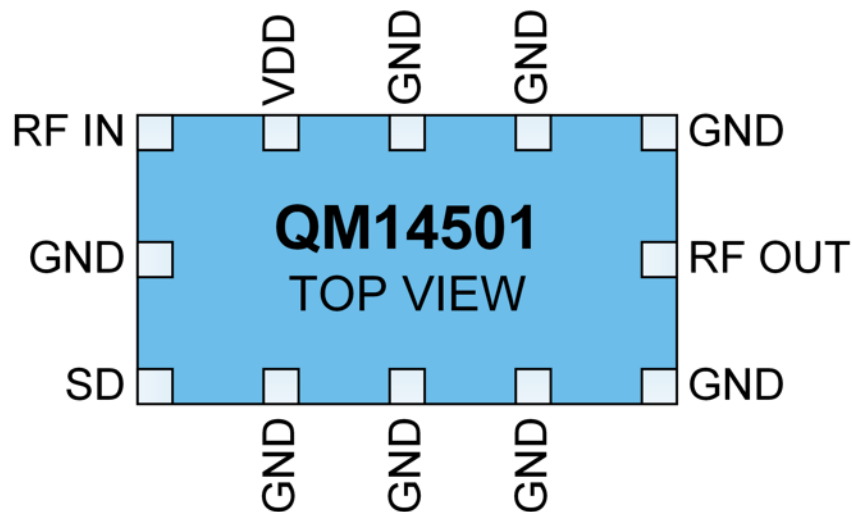

GPS, GLONASS, and BeiDou Low Noise Amplifier With Integrated Output SAW Filter

Timing Diagram

Power – Up/Down Sequence

It is very important that the user adhere to the correct power – up/down sequence in order to avoid damaging the device. When V_{DD} is not applied to part, all the control lines must be set to 0 V (or ground).

ON Sequence: First turn ON V_{DD} , apply control signals (EN) and then RF signal.

OFF Sequence: First turn OFF the RF signal then control signals (EN) and finally turn OFF the V_{DD} .

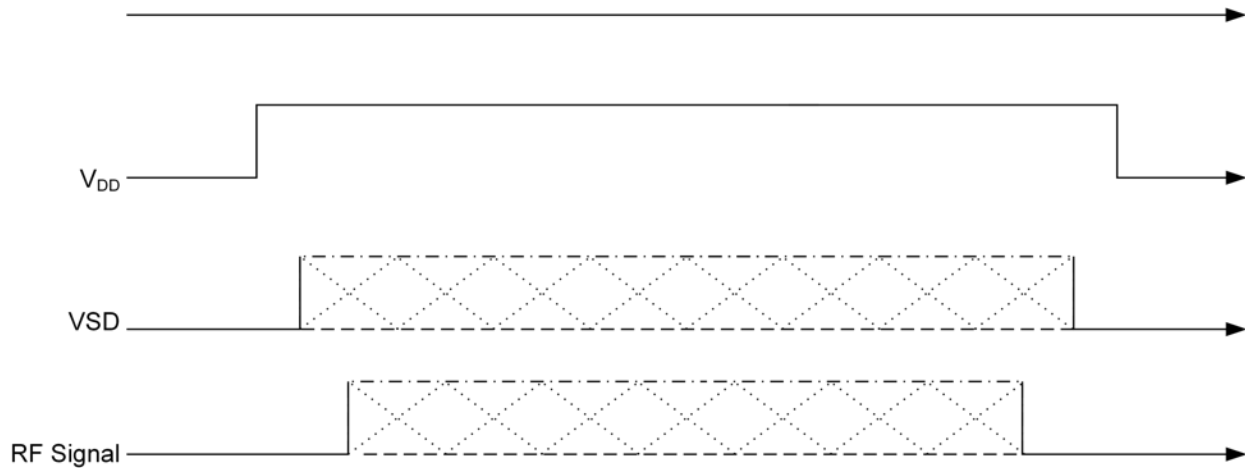

GPS, GLONASS, and BeiDou Low Noise Amplifier With Integrated Output SAW Filter

Evaluation Board Schematic

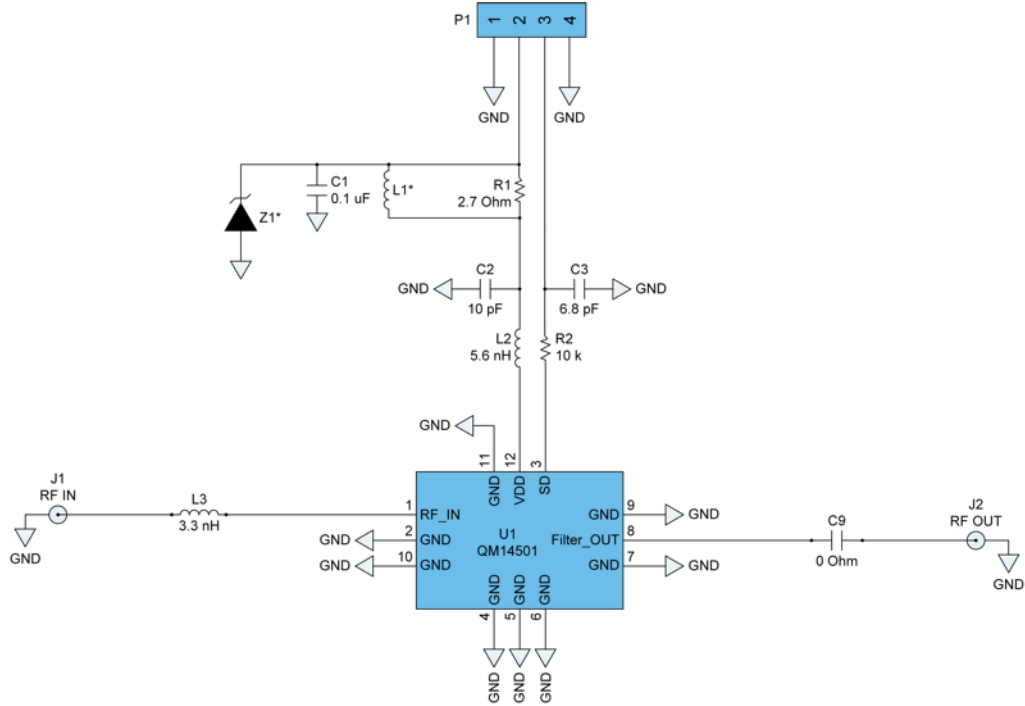

Evaluation Board Layout

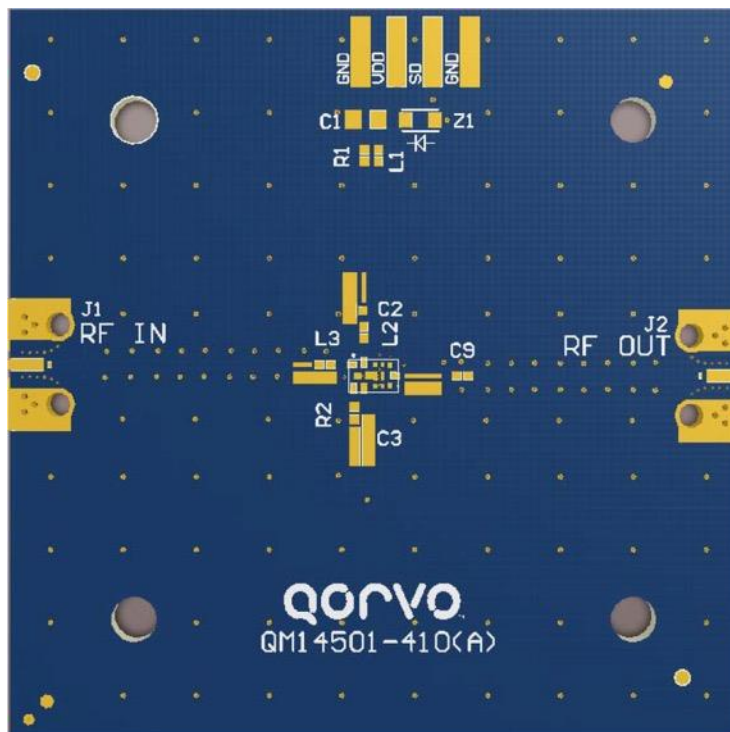

GPS, GLONASS, and BeiDou Low Noise Amplifier With Integrated Output SAW Filter

Applications Schematic

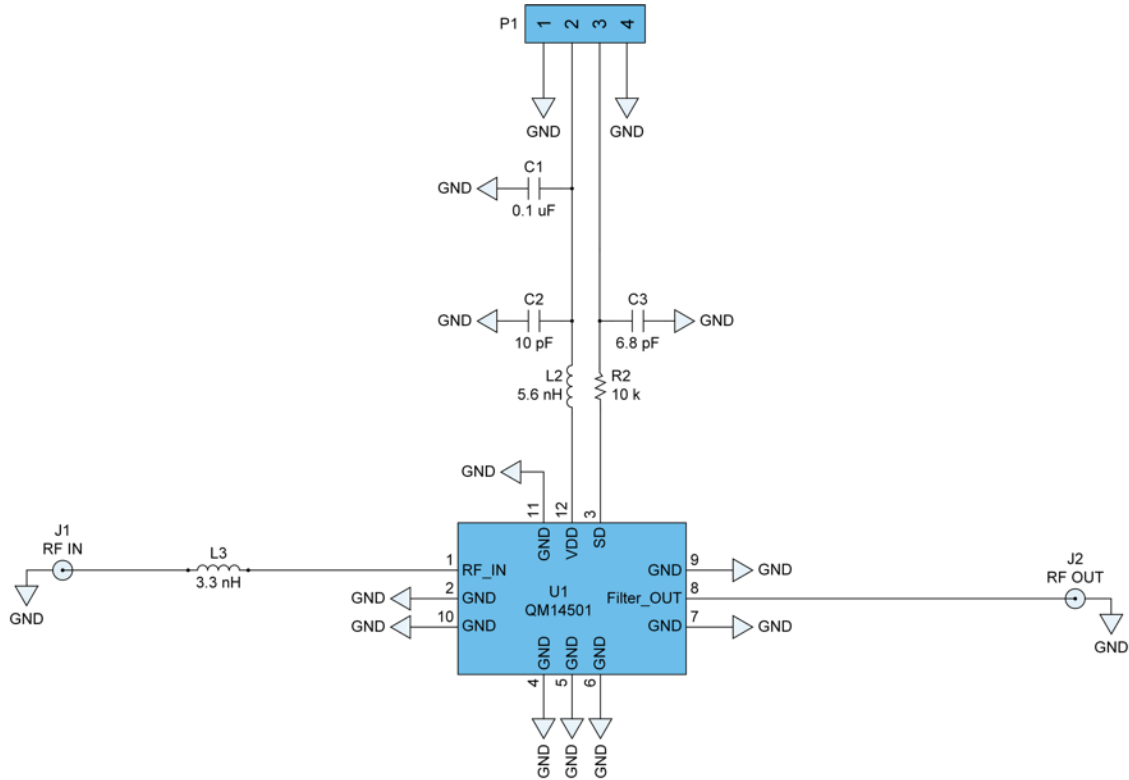

GPS, GLONASS, and BeiDou Low Noise Amplifier With Integrated Output SAW Filter

Package Outline

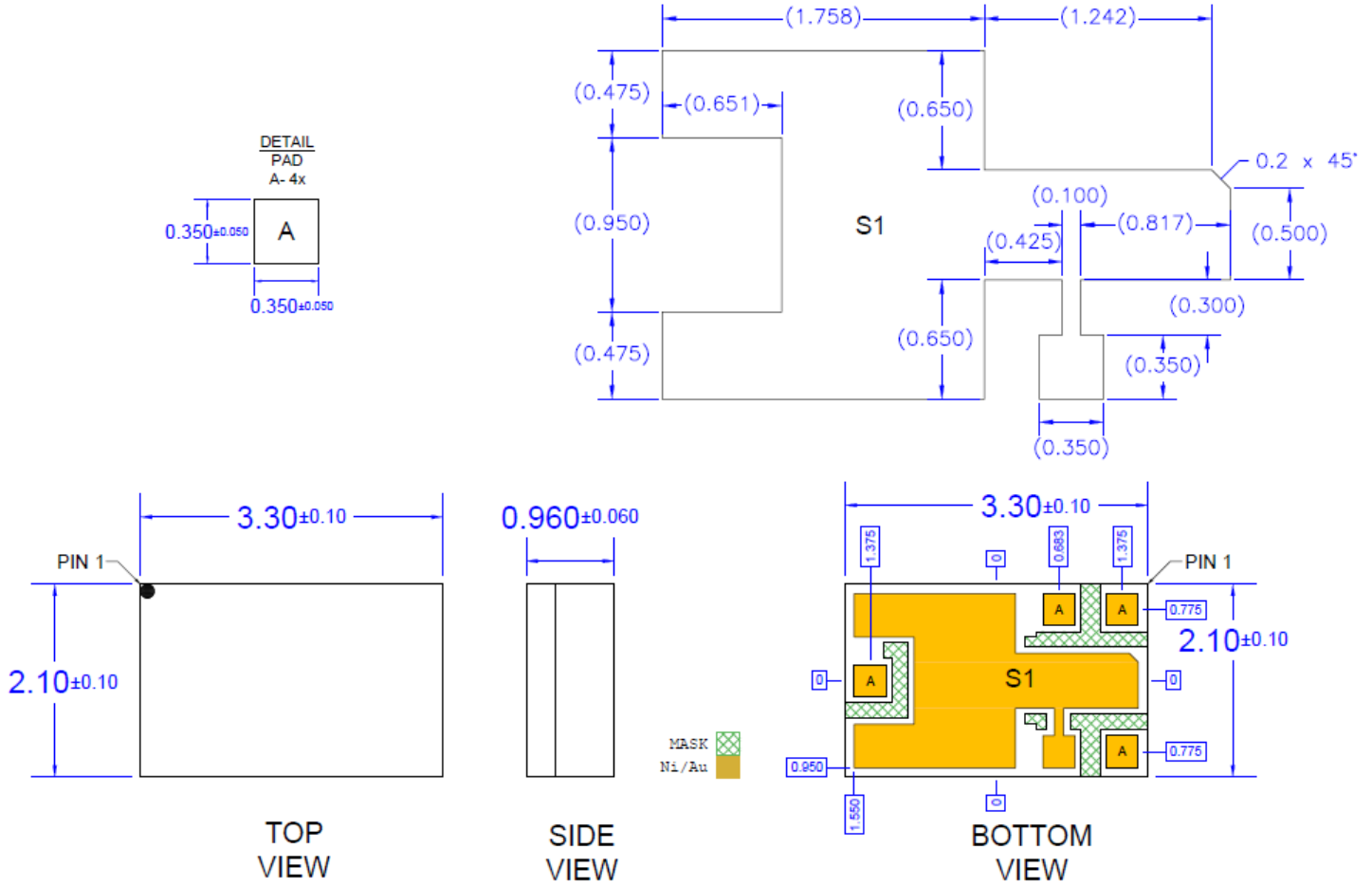

GPS, GLONASS, and BeiDou Low Noise Amplifier With Integrated Output SAW Filter

PCB Patterns

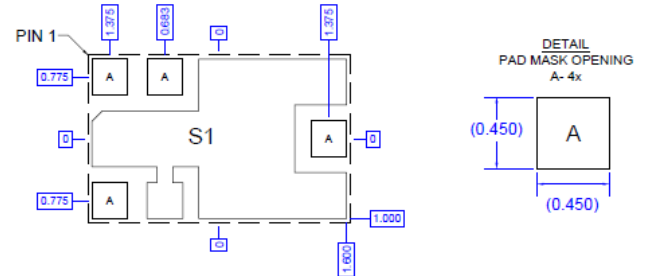
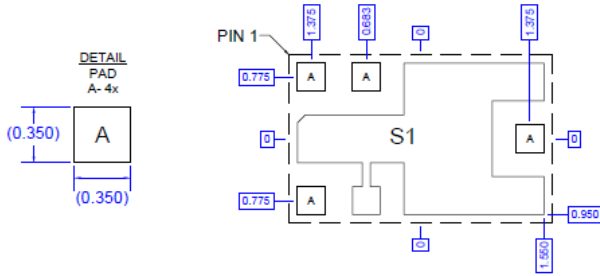
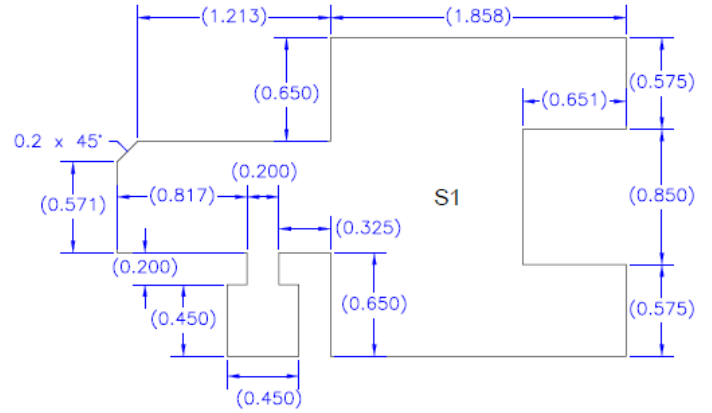
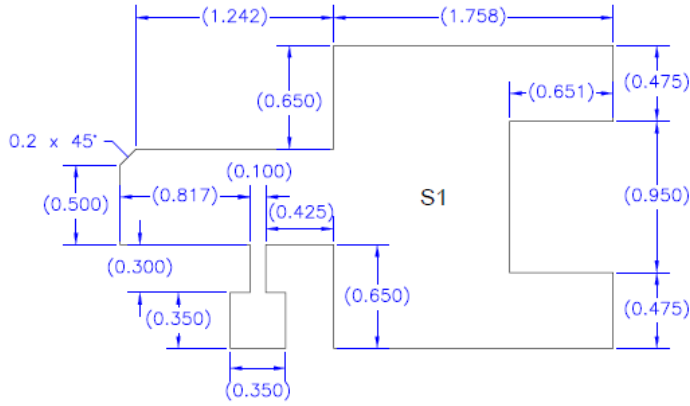

RECOMMENDED
LAND PATTERN

RECOMMENDED
LAND PATTERN MASK

GPS, GLONASS, and BeiDou Low Noise Amplifier With Integrated Output SAW Filter

Solderability

Compatible with both lead-free (260 °C max. reflow temperature) and tin/lead (245 °C max. reflow temperature) soldering processes.

Package lead plating: Plated Au over Ni

RoHS Compliance

This part is compliant with the 2011/65/EU RoHS directive (Restrictions on the Use of Certain Hazardous Substances in Electrical and Electronic Equipment), as amended by Directive 2015/863/EU.

This product also has the following attributes:

- Lead free
- Halogen Free (Chlorine, Bromine)
- Antimony Free
- TBBP-A (C₁₅H₁₂Br₄O₂) Free



GPS, GLONASS, and BeiDou Low Noise Amplifier With Integrated Output SAW Filter

REVISION HISTORY

Revision	Description
DS20160310	Initial Release.
DS20160401	Updated ordering information.
DS20170510	Converted from RFMD to Qorvo template. Changed ordering information (pg. 1) – “QM14501PCK-410” changed to “QM14501PCK401”.
D - 20180315	Added “Not For New Designs” information
E - 20180510	Removed “Not For New Designs” marks – part will be supported into the future
F - 20200219	Updated Package Outline and land pattern drawings

Contact Information

For the latest specifications, additional product information, worldwide sales and distribution locations:

Web: www.qorvo.com

Tel: 1-844-890-8163

Email: customer.support@qorvo.com

Important Notice

The information contained herein is believed to be reliable; however, Qorvo makes no warranties regarding the information contained herein and assumes no responsibility or liability whatsoever for the use of the information contained herein. All information contained herein is subject to change without notice. Customers should obtain and verify the latest relevant information before placing orders for Qorvo products. The information contained herein or any use of such information does not grant, explicitly or implicitly, to any party any patent rights, licenses, or any other intellectual property rights, whether with regard to such information itself or anything described by such information. **THIS INFORMATION DOES NOT CONSTITUTE A WARRANTY WITH RESPECT TO THE PRODUCTS DESCRIBED HEREIN, AND QORVO HEREBY DISCLAIMS ANY AND ALL WARRANTIES WITH RESPECT TO SUCH PRODUCTS WHETHER EXPRESS OR IMPLIED BY LAW, COURSE OF DEALING, COURSE OF PERFORMANCE, USAGE OF TRADE OR OTHERWISE, INCLUDING THE IMPLIED WARRANTIES OF MERCHANTABILITY AND FITNESS FOR A PARTICULAR PURPOSE.**

Without limiting the generality of the foregoing, Qorvo products are not warranted or authorized for use as critical components in medical, life-saving, or life-sustaining applications, or other applications where a failure would reasonably be expected to cause severe personal injury or death.

Copyright 2017 © Qorvo, Inc. | Qorvo is a registered trademark of Qorvo, Inc.

X-ON Electronics

Largest Supplier of Electrical and Electronic Components

Click to view similar products for [RF Amplifier](#) category:

Click to view products by [Qorvo](#) manufacturer:

Other Similar products are found below :

[A82-1](#) [BGA622H6820XTSA1](#) [BGA 728L7 E6327](#) [BGB719N7ESDE6327XTMA1](#) [HMC397-SX](#) [HMC405](#) [HMC561-SX](#) [HMC8120-SX](#)
[HMC8121-SX](#) [HMC-ALH382-SX](#) [HMC-ALH476-SX](#) [SE2433T-R](#) [SMA3101-TL-E](#) [SMA39](#) [A66-1](#) [A66-3](#) [A67-1](#) [LX5535LQ](#) [LX5540LL](#)
[MAAM02350](#) [HMC3653LP3BETR](#) [HMC549MS8GETR](#) [HMC-ALH435-SX](#) [SMA101](#) [SMA32](#) [SMA411](#) [SMA531](#) [SST12LP17E-XX8E](#)
[SST12LP19E-QX6E](#) [WPM0510A](#) [HMC5929LS6TR](#) [HMC5879LS7TR](#) [HMC1126](#) [HMC1087F10](#) [HMC1086](#) [HMC1016](#) [SMA1212](#)
[MAX2689EWS+T](#) [MAAMSS0041TR](#) [MAAM37000-A1G](#) [LTC6430AIUF-15#PBF](#) [CHA5115-QDG](#) [SMA70-2](#) [SMA4011](#) [A231](#) [HMC-](#)
[AUH232](#) [LX5511LQ](#) [LX5511LQ-TR](#) [HMC7441-SX](#) [HMC-ALH310](#)