

### Product Overview

The QPA9127 is a cascadable, high linearity gain block amplifier in a low-cost surface mount package. At 3.5 GHz, the amplifier provides 20 dB gain, +35 dBm OIP3 and 1.4 dB Noise Figure while drawing 70 mA current from a 5V supply.

The QPA9127 provides very flat gain across a broad range of frequencies with the integration of a shut-down biasing capability to allow for operation for TDD applications. The low noise figure and high linearity performance allows the device to be used in both receiver and transmitter chains for high performance systems. The internal active bias circuit also enables stable operation over bias and temperature variations and can be biased from a single positive supply ranging from +3.3 to +5 volts. The amplifier is internally matched using a high-performance E-pHEMT process and is housed in a small 2x2 mm surface-mount package.

The QPA9127 covers the 1 – 6 GHz frequency band and is targeted for wireless infrastructure or other applications requiring high linearity and/or low noise figure.



8 Pad 2 x 2 mm DFN Package

### Key Features

- 1.0 – 6.0 GHz Operational
- 50Ω Matched RF Input and Output
- 0.3dB Gain Flatness over 400 MHz Bandwidth
- 20 dB Gain
- +35 dBm Output IP3
- +19.5 dBm P1dB
- Noise Figure 1.4dB
- 1.8V Logic Compatible Shutdown Control

### Functional Block Diagram

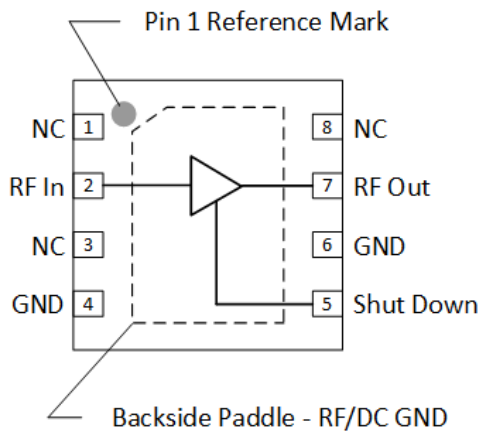

Top View

### Applications

- 5G m-MIMO
- Mobile Infrastructure
- Repeater / DAS
- General Purpose Wireless
- TDD / FDD System
- Defense Communication

### Ordering Information

Part No.	Description
QPA9127TR7	2,500 pieces on a 7" reel (standard)
QPA9127 EVB-01	Evaluation Board

## Absolute Maximum Ratings

Parameter	Rating
Storage Temperature	-65 °C to +150 °C
RF Input Power, CW, 50 Ω, T=25 °C	+22 dBm
Device Voltage (V <sub>DD</sub> )	+7 V
Dissipated Power (P <sub>DISS</sub> )	0.7 W

Exceeding any one or a combination of the Absolute Maximum Rating conditions may cause permanent damage to the device. Extended application of Absolute Maximum Rating conditions to the device may reduce device reliability.

## Recommended Operating Conditions

Parameter	Min	Typ	Max	Units
Device Voltage (V <sub>DD</sub> )	+3.3	+5.0	+5.25	V
T <sub>CASE</sub>	-40		+105	°C
T <sub>j</sub> for >10 <sup>6</sup> hours MTTF			+190	°C

Electrical specifications are measured at specified test conditions. Specifications are not guaranteed over all recommended operating conditions.

## Electrical Specifications

Parameter	Conditions <sup>(1)</sup>	Min	Typ	Max	Units
Operational Frequency Range		1000		6000	MHz
Test Frequency			3500		MHz
Gain			20		dB
Gain Flatness	Over 400 MHz		0.3		dB
Input Return Loss			10		dB
Output Return Loss			10		dB
Output P1dB			19.5		dBm
Output IP3	P <sub>out</sub> = +1 dBm/tone, Δf = 1 MHz		35		dBm
Noise Figure	EVB trace loss excluded		1.4		dB
Device Current, I <sub>DD</sub>	ON, Normal operation, V <sub>PD</sub> = 0 V		70		mA
	OFF, Shut down, V <sub>PD</sub> = 1.8 V		4		mA
Device Control Voltage, V <sub>PD</sub>	ON, Logic Low	0		0.63	V
	OFF, Logic High	1.17		V <sub>DD</sub>	V
Control Pin Current, I <sub>PD</sub>			150		μA
Device ON or OFF Timing	50% of V <sub>PD</sub> to 90% or 10% RF Output		0.1		μS
Thermal Resistance, θ <sub>JC</sub>	Junction to case		50.0		°C/W

Notes:

1. Test conditions unless otherwise noted: V<sub>DD</sub> on EVB = +5.0V, V<sub>PD</sub> = 0V, Temp = +25 °C, 50 Ω system.

## Logic Table

Parameter, V <sub>PD</sub>	High	Low
Device State	OFF	ON

## Evaluation Board - QPA9127EVB-01

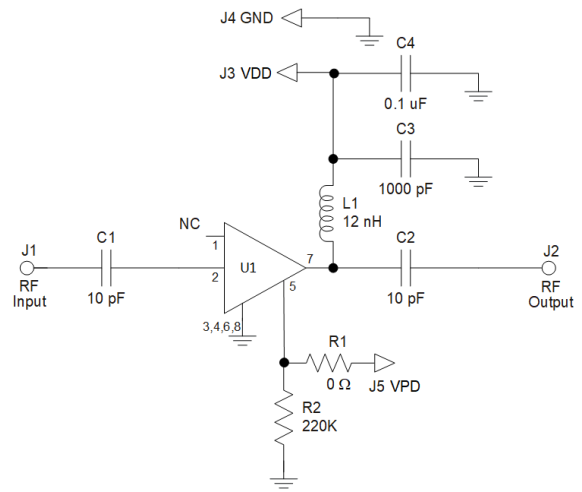
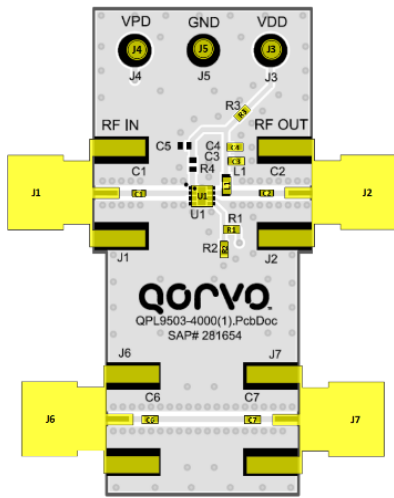

**Notes:**

1. See Evaluation Board PCB Information for material and stack-up
2. R3, 0  $\Omega$  jumper, is not shown on the schematic. It could be replaced with cooper trace in target layout

## Bill of Material

Ref. Des.	Value	Description	Manuf.	Part Number
n/a	-	Printed Circuit Board	Qorvo	
U1	-	High Gain High Linearity Amplifier	Qorvo	QPA9127
R1, R3	0 $\Omega$	Res, 0 $\Omega$ , 0402, 1/10W	various	
R2	220 K $\Omega$	Res, 220 K $\Omega$ , 0402, 5%, 1/16W	various	
C1, C2	10 pF	Cap, 10 pF, 0402, 5%, 50V C0G	various	
C3	1000 pF	Cap, 1000 pF, 0402, 10%, 50V X7R	various	
C4	0.1 $\mu$ F	Cap, 0.1 $\mu$ F, 0402, 10%, 50V, X5R	various	
L1	12 nH	Ind, 12 nH, 0603, 5%, W/W	Coilcraft	0603HP-12NXGLW
J1, J2	-	Conn, SMA F STRT .062"	Cinch Connectivity	142-0701-851

## Typical Performance on EVB

Parameter	Conditions	Typical Value					Units
		3000	3500	4000	4500	5000	
Frequency							MHz
Gain	Small Signal	19.8	20.6	21.4	22.6	22.8	dB
Input Return Loss		15.2	19.1	20.6	17.4	14.9	dB
Output Return Loss		13.6	10.8	9.1	7.2	5.2	dB
Noise Figure		1.28	1.45	1.48	1.54	1.56	dB
Output P1dB		20.3	19.5	18.9	17.8	18.1	dBm
Output IP3	Pout = +1 dBm/tone, $\Delta$ f = 1 MHz	34.9	34.9	34.4	34.4	34.2	dBm
Device Current	I <sub>DD</sub>	59					mA

**Notes:**

1. Test Conditions unless otherwise noted: V<sub>DD</sub> on EVB = +5.0V, V<sub>PD</sub> = 0 V, Temp.=+25 °C

Performance Plots – QPA9127EVb-01

Test conditions unless otherwise noted:  $V_{DD}$  on EVB = +5.0 V,  $I_{DD}$  = 70 mA,  $V_{PD}$  = 0 V, Temp. = +25 °C

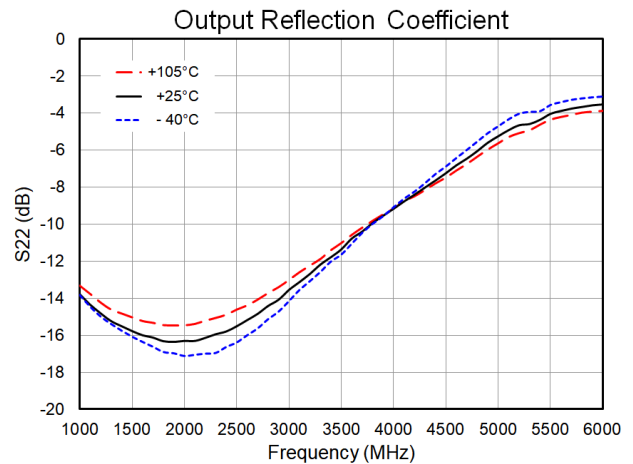
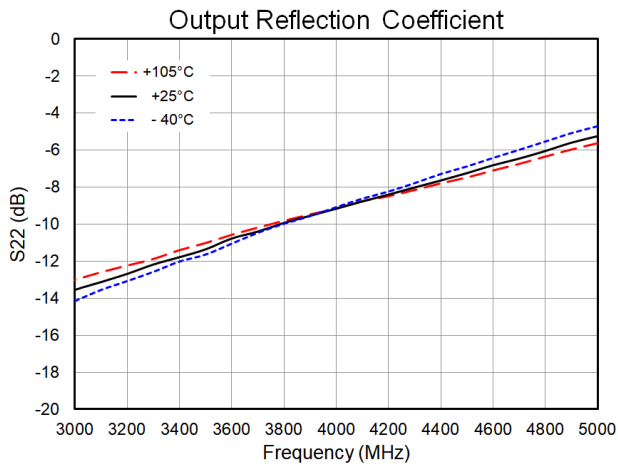
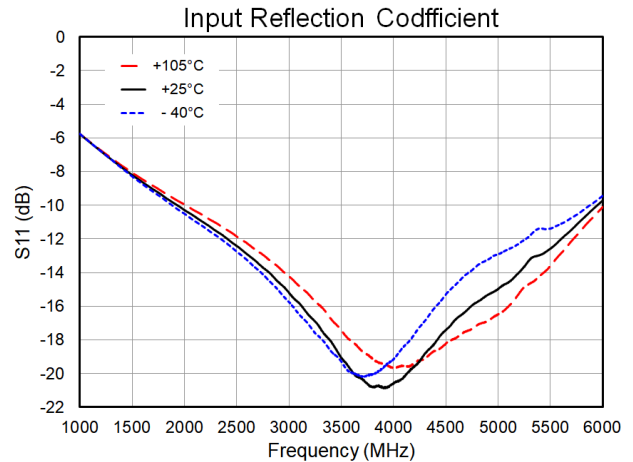
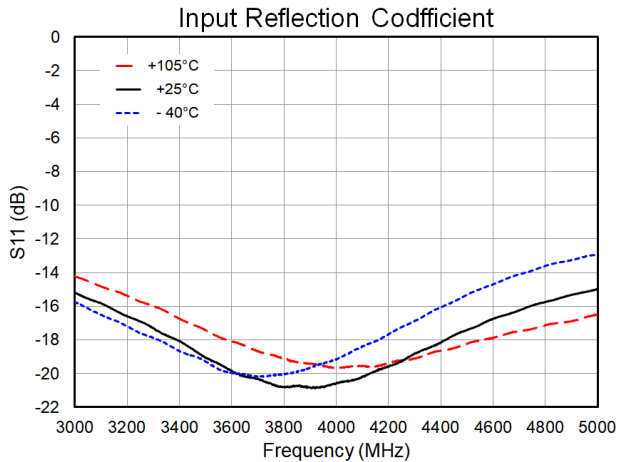
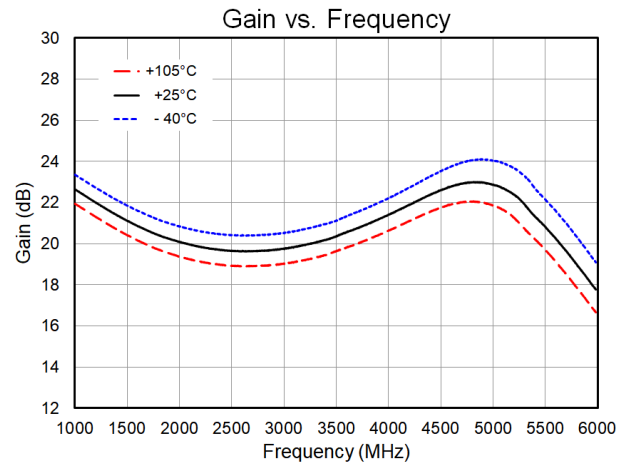
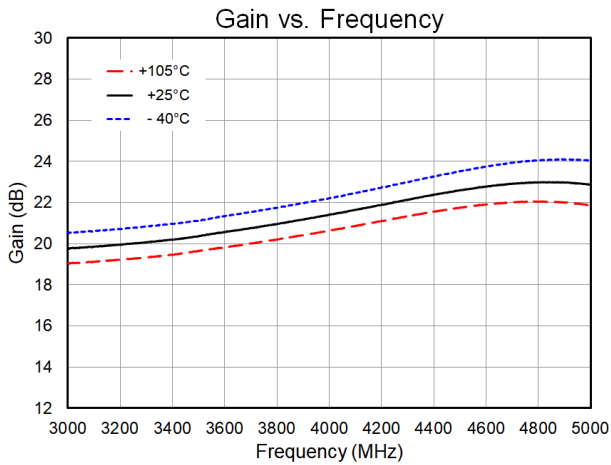

Performance Plots – QPA9127EVB-01 (Continue)

Test conditions unless otherwise noted:  $V_{DD} = +5.0\text{ V}$ ,  $I_{DD} = 70\text{ mA}$ ,  $V_{PD} = 0\text{ V}$ , Temp. =  $+25\text{ }^{\circ}\text{C}$

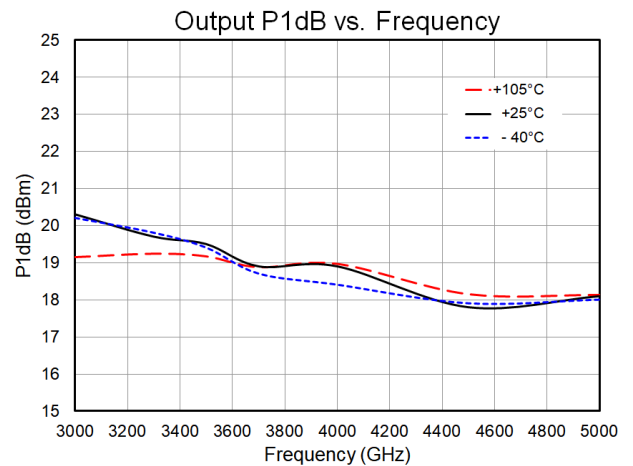
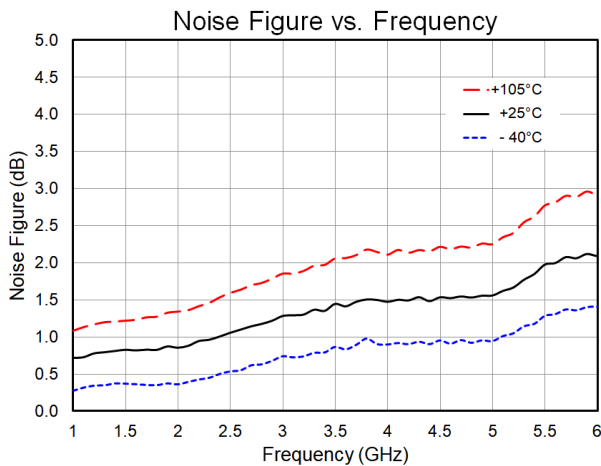
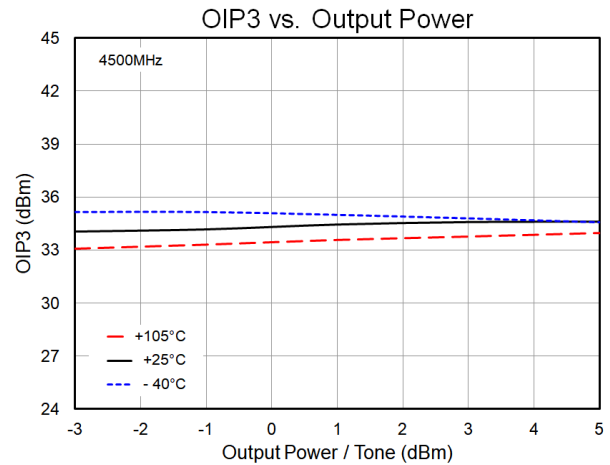
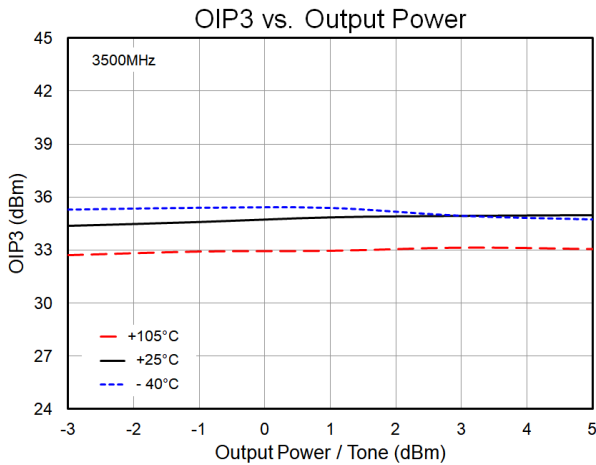
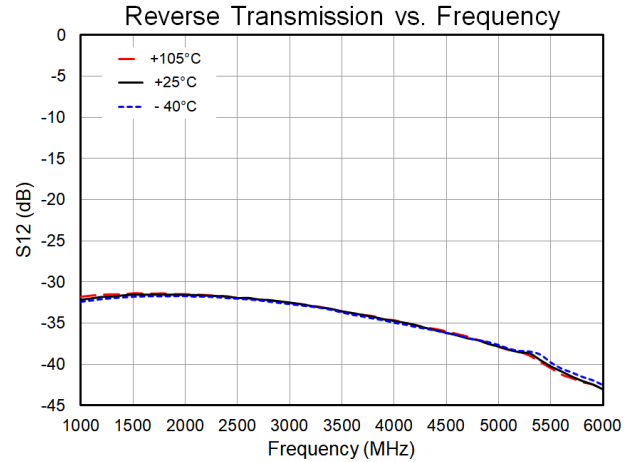
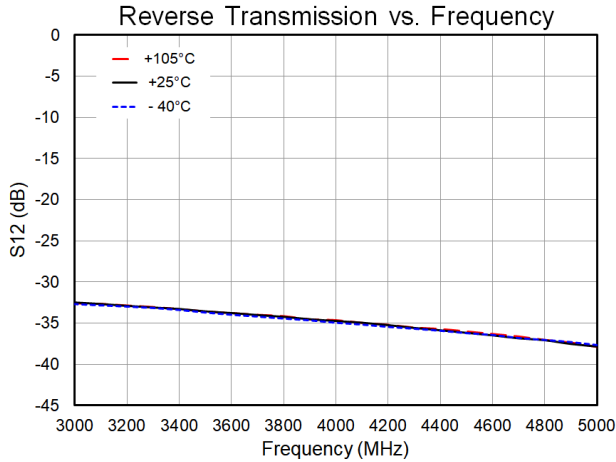

Performance Plots – QPA9127EVB-01 (Continue)

Test conditions unless otherwise noted:  $V_{DD}$  on EVB = +5V,  $I_{DD}$  = 70 mA,  $V_{PD}$  = 0 V, Temp.=+25 °C, on QPA9127EVB01

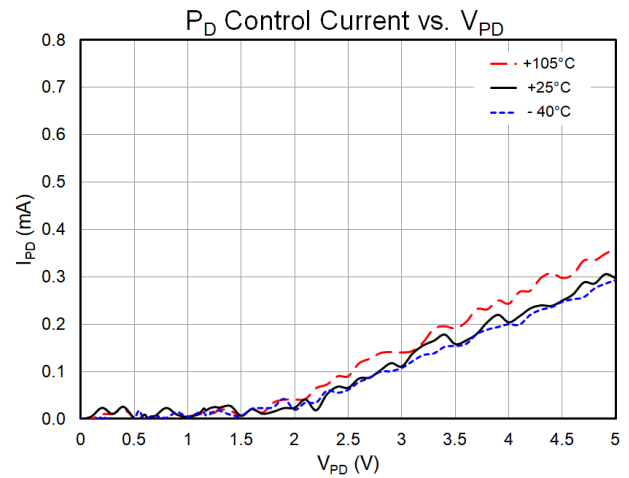
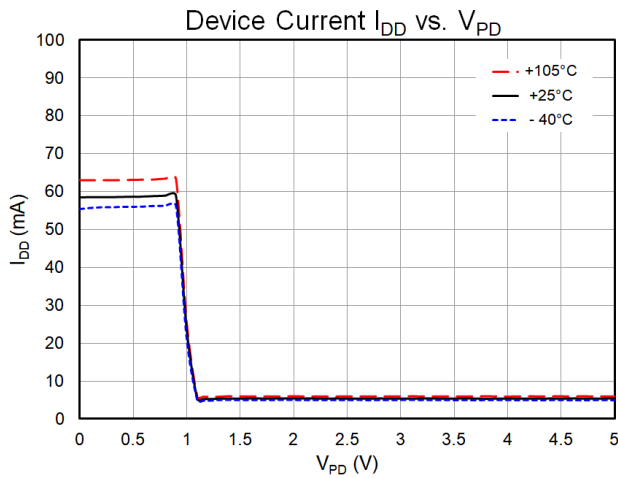
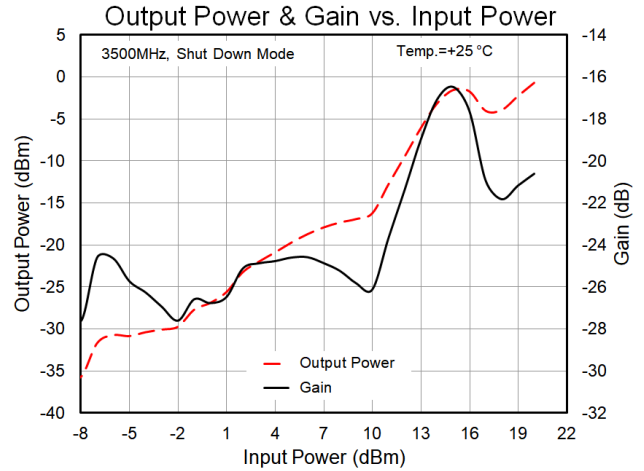
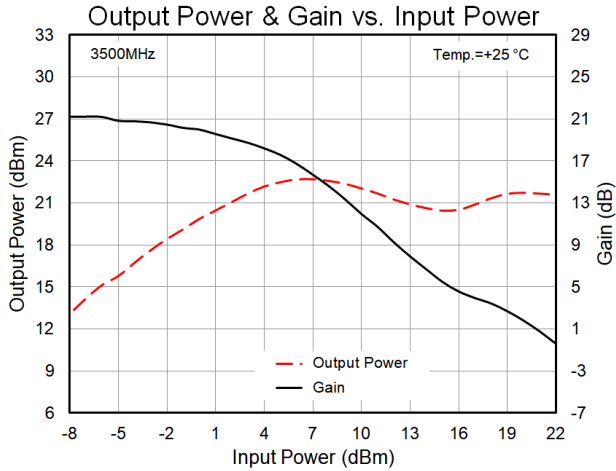

## Evaluation Board PCB Information

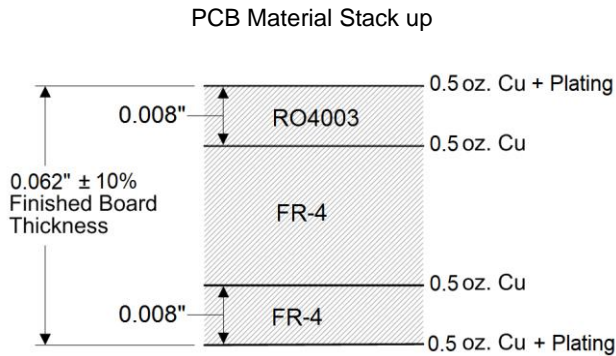

50 Ω line dimensions: width = 0.0182", spacing = 0.020"

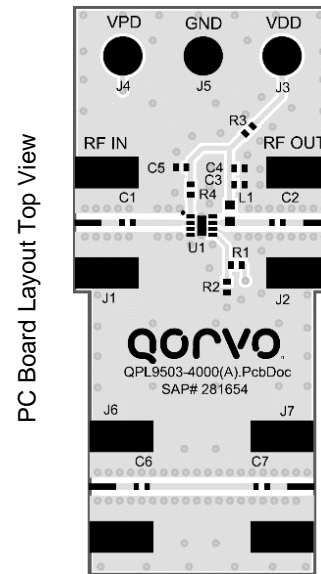

## Pad Configuration and Description

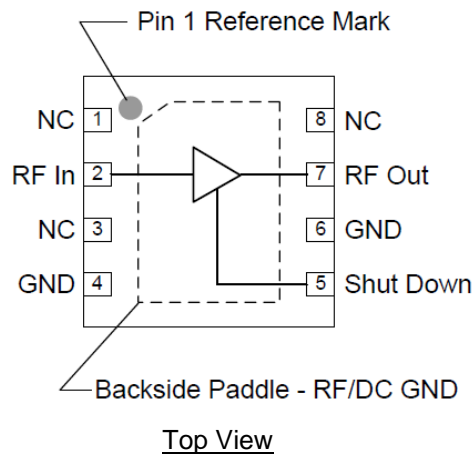

Pad No.	Label	Description
1, 3, 4, 6, 8	NC or GND	No electrical connection internally. It may be left floating or connected to ground. Land pads should be provided for PCB mounting integrity.
2	RF IN	RF input. Internally matched to 50Ω. External DC Block required
5	Shut Down	Amplifier ON/OFF Logic control input, controls internal bias voltage regulator
7	RF OUT	RF output and DC supply V <sub>DD</sub> input. Internally matched to 50Ω. External chock and DC Block capacitor required.
Backside Paddle	GND	RF/DC ground. Use recommended via pattern to minimize inductance and thermal resistance. See PCB Mounting Pattern for suggested footprint.

**Package Marking and Dimensions**

Marking: Pin 1 marker – Dot and Logo – Q  
 Part Number – 9127  
 Trace Code – XXXX up to 4 Characters assigned by sub-contractor

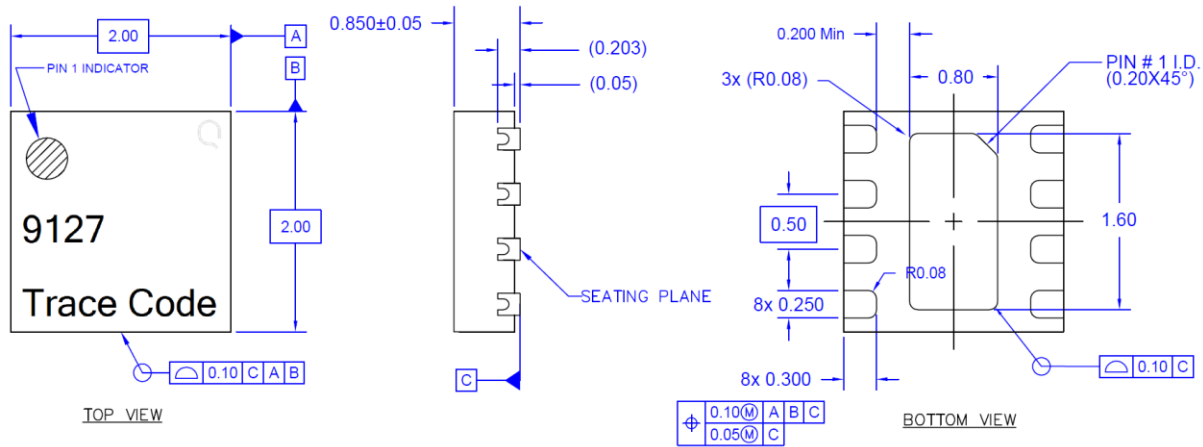

- Notes:
1. All dimensions are in millimeters. Angles are in degrees.
  2. The terminal #1 identifier and terminal numbering conform to JESD 95-1 SPP-012.
  3. Contact plating: NiPdAu

**Recommended PCB Layout Pattern**

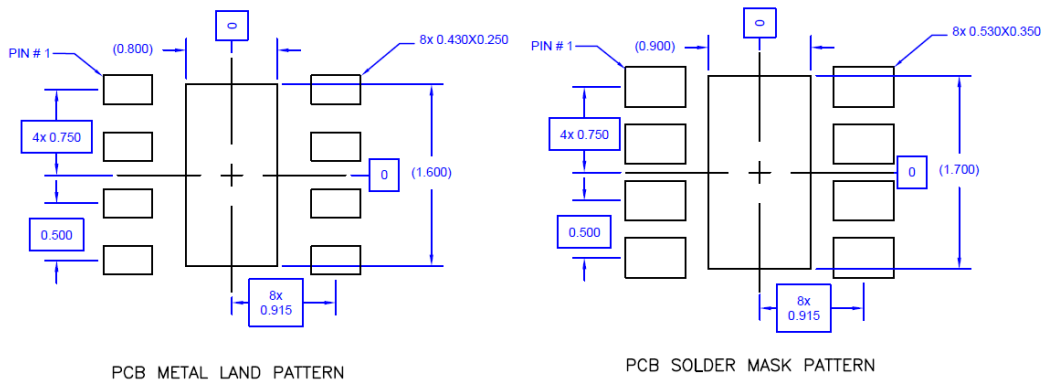

- Notes:
1. All dimensions are in millimeters. Angles are in degrees.
  2. Use 1 oz. copper minimum for top and bottom layer metal.
  3. Via holes are required under the backside paddle of this device for proper RF/DC grounding and thermal dissipation. We recommend a 0.35mm (#80/.0135") diameter bit for drilling via holes and a final plated thru diameter of 0.25 mm (0.01").
  4. Ensure good package backside paddle solder attach for reliable operation and best electrical performance.



Tape and Reel Information – Carrier and Cover Tape Dimensions

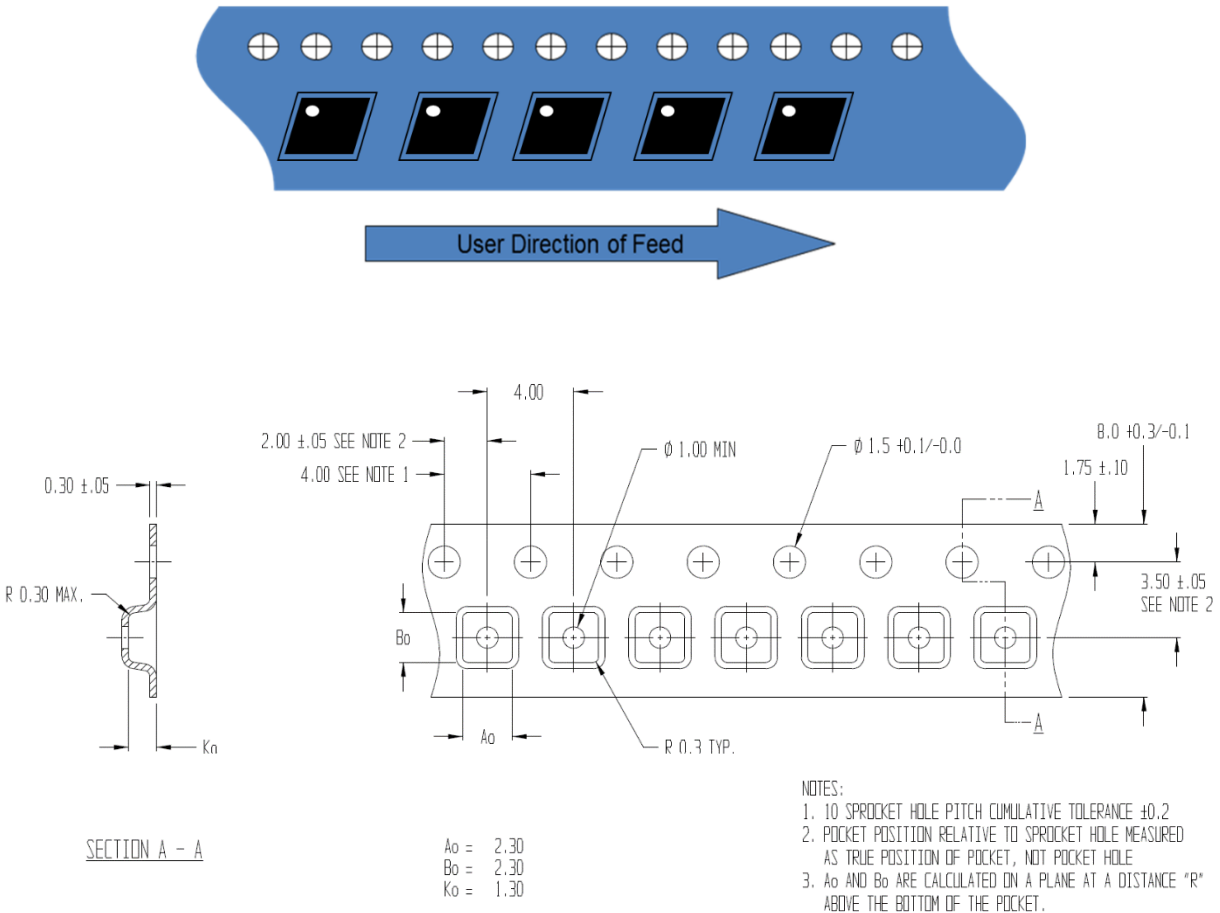

Feature	Measure	Symbol	Size (in)	Size (mm)
Cavity	Length	A0	0.091	2.30
	Width	B0	0.091	2.30
	Depth	K0	0.051	1.30
	Pitch	P1	0.157	4.00
Centerline Distance	Cavity to Perforation - Length Direction	P2	0.079	2.00
	Cavity to Perforation - Width Direction	F	0.138	3.50
Cover Tape	Width	C	0.213	5.40
Carrier Tape	Width	W	0.315	8.00

**Tape and Reel Information – Reel Dimensions**

Standard T/R size = 2,500 pieces on a 7" reel.

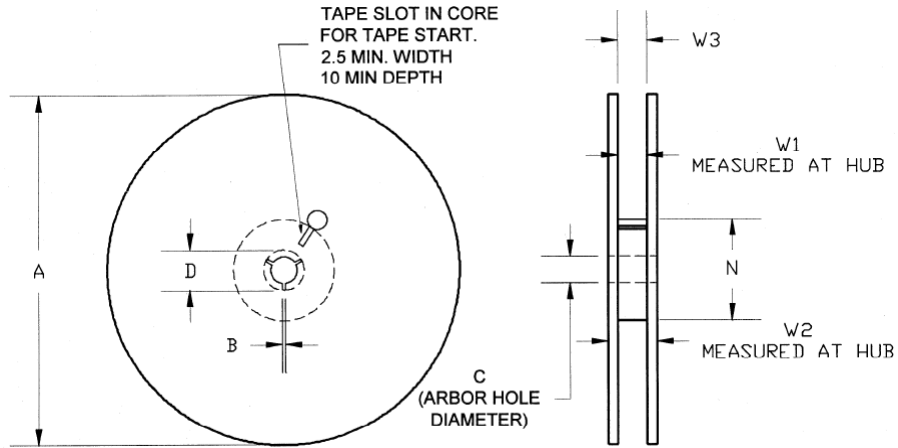

Feature	Measure	Symbol	Size (in)	Size (mm)
Flange	Diameter	A	6.969	177.0
	Thickness	W2	0.559	14.2
	Space Between Flange	W1	0.346	8.8
Hub	Outer Diameter	N	2.283	58.0
	Arbor Hole Diameter	C	0.512	13.0
	Key Slit Width	B	0.079	2.0
	Key Slit Diameter	D	0.787	20.0

**Tape and Reel Information – Tape Length and Label Placement**

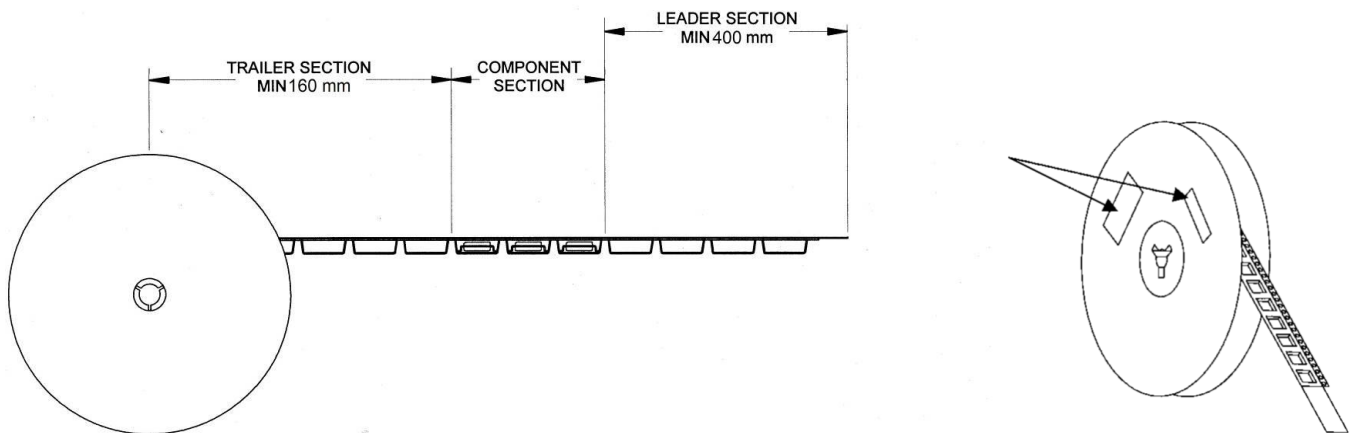

- Notes:
1. Empty part cavities at the trailing and leading ends are sealed with cover tape. See EIA 481-1-A.
  2. Labels are placed on the flange opposite the sprockets in the carrier tape.

## Handling Precautions

Parameter	Rating	Standard
ESD – Human Body Model (HBM)	Class 1B	ESDA / JEDEC JS-001-2012
ESD – Charged Device Model (CDM)	Class C3	JEDEC JESD22-C101F
MSL – Moisture Sensitivity Level	Level 1	IPC/JEDEC J-STD-020



Caution!  
ESD-Sensitive Device

## Solderability

Compatible with both lead-free (260°C max. reflow temperature) and tin/lead (245°C max. reflow temperature) soldering processes. Solder profiles available upon request.

Contact plating: NiPdAu

## RoHS Compliance

This part is compliant with 2011/65/EU RoHS directive (Restrictions on the Use of Certain Hazardous Substances in Electrical and Electronic Equipment) as amended by Directive 2015/863/EU.

This product also has the following attributes:

- Lead Free
- Halogen Free (Chlorine, Bromine)
- Antimony Free
- TBBP-A (C<sub>15</sub>H<sub>12</sub>Br<sub>4</sub>O<sub>2</sub>) Free
- PFOS Free
- SVHC Free



## Contact Information

For the latest specifications, additional product information, worldwide sales and distribution locations:

Web: [www.qorvo.com](http://www.qorvo.com)

Tel: 1-844-890-8163

Email: [customer.support@qorvo.com](mailto:customer.support@qorvo.com)

## Important Notice

The information contained herein is believed to be reliable; however, Qorvo makes no warranties regarding the information contained herein and assumes no responsibility or liability whatsoever for the use of the information contained herein. All information contained herein is subject to change without notice. Customers should obtain and verify the latest relevant information before placing orders for Qorvo products. The information contained herein or any use of such information does not grant, explicitly or implicitly, to any party any patent rights, licenses, or any other intellectual property rights, whether with regard to such information itself or anything described by such information. **THIS INFORMATION DOES NOT CONSTITUTE A WARRANTY WITH RESPECT TO THE PRODUCTS DESCRIBED HEREIN, AND QORVO HEREBY DISCLAIMS ANY AND ALL WARRANTIES WITH RESPECT TO SUCH PRODUCTS WHETHER EXPRESS OR IMPLIED BY LAW, COURSE OF DEALING, COURSE OF PERFORMANCE, USAGE OF TRADE OR OTHERWISE, INCLUDING THE IMPLIED WARRANTIES OF MERCHANTABILITY AND FITNESS FOR A PARTICULAR PURPOSE.**

Without limiting the generality of the foregoing, Qorvo products are not warranted or authorized for use as critical components in medical, life-saving, or life-sustaining applications, or other applications where a failure would reasonably be expected to cause severe personal injury or death.

Copyright 2019 © Qorvo, Inc. | Qorvo is a registered trademark of Qorvo, Inc.

## X-ON Electronics

Largest Supplier of Electrical and Electronic Components

*Click to view similar products for [RF Amplifier](#) category:*

*Click to view products by [Qorvo](#) manufacturer:*

Other Similar products are found below :

[A82-1](#) [BGA622H6820XTSA1](#) [BGA 728L7 E6327](#) [BGB719N7ESDE6327XTMA1](#) [HMC397-SX](#) [HMC405](#) [HMC561-SX](#) [HMC8120-SX](#)  
[HMC8121-SX](#) [HMC-ALH382-SX](#) [HMC-ALH476-SX](#) [SE2433T-R](#) [SMA3101-TL-E](#) [SMA39](#) [A66-1](#) [A66-3](#) [A67-1](#) [LX5535LQ](#) [LX5540LL](#)  
[MAAM02350](#) [HMC3653LP3BETR](#) [HMC549MS8GETR](#) [HMC-ALH435-SX](#) [SMA101](#) [SMA32](#) [SMA411](#) [SMA531](#) [SST12LP17E-XX8E](#)  
[SST12LP19E-QX6E](#) [WPM0510A](#) [HMC5929LS6TR](#) [HMC5879LS7TR](#) [HMC1126](#) [HMC1087F10](#) [HMC1086](#) [HMC1016](#) [SMA1212](#)  
[MAX2689EWS+T](#) [MAAMSS0041TR](#) [MAAM37000-A1G](#) [LTC6430AIUF-15#PBF](#) [CHA5115-QDG](#) [SMA70-2](#) [SMA4011](#) [A231](#) [HMC-](#)  
[AUH232](#) [LX5511LQ](#) [LX5511LQ-TR](#) [HMC7441-SX](#) [HMC-ALH310](#)