

Product Overview

The QPA9133 is an 100 Ω differential input to 50 Ω single-ended output, wideband gain block. It is well suited as the 5G m-MIMO BTS Tx path gain stage, to directly interface with the DAC of the transceiver, eliminating the need for a discrete Balun.

With Qorvo’s GaAs E-pHEMT process, this amplifier delivers exceptional performance with 18 dB of small signal gain and 34 dBm output 3rd order intercept (OIP3). The amplifier has excellent gain flatness of 0.5 dB over any 400 MHz bandwidth and a CMRR of 35dB. The amplifier features a shut-down function through V_{PD} control Pin.

The QPA9133 is optimized over 3.3 GHz to 5.0 GHz band and is housed in a compact 2X2mm SMT package



12-pin, 2 x 2 mm SMT Package

Key Features

- 3.3 GHz to 5.0 GHz Operational Frequency
- 100 Ohm Differential Input
- 50 Ohm Single-Ended Output
- +34 dBm OIP3
- 18 dB Gain
- Small 2 x 2 mm SMT Package

Functional Block Diagram

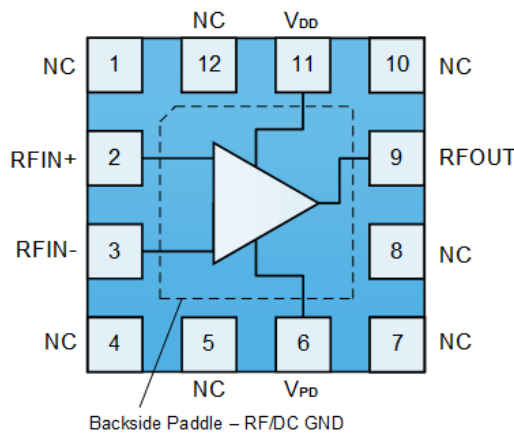

Top View

Applications

- 5G m-MIMO
- Mobile Infrastructure
- General Purpose Wireless
- TDD / FDD System

Ordering Information

Part No.	Description
QPA9133TR7	2500 pcs on 7" reel (standard)
QPA9133EVB-01	Differential Input Evaluation Board

Absolute Maximum Ratings

Parameter	Rating
Storage Temperature	-65 to +150°C
RF Input Power, CW, 50 Ω, T=25 °C	+22 dBm
Device Voltage (V _{DD})	+7 V
Dissipated Power (P _{DISS})	0.7 W

Exceeding any one or a combination of the Absolute Maximum Rating conditions may cause permanent damage to the device. Extended application of Absolute Maximum Rating conditions to the device may reduce device reliability.

Recommended Operating Conditions

Parameter	Min	Typ	Max	Units
Device Voltage (V _{DD})	+3.3	+5	+5.25	V
T _{CASE}	-40		+105	°C
T _j for >10 ⁶ hours MTTF			+190	°C

Electrical specifications are measured at specified test conditions. Specifications are not guaranteed over all recommended operating conditions.

Electrical Specifications

Parameter	Conditions ⁽¹⁾	Min	Typ	Max	Units
Operational Frequency Range		3300		5000	MHz
Test Frequency			3500		MHz
Small Signal Gain ⁽²⁾		17	18	21	dB
Gain Flatness	Any 400 MHz BW within band		0.5		dB
Input Return Loss ⁽²⁾			10		dB
Output Return Loss			10		dB
Output P1dB		+18	+19		dBm
Output IP3	P _{out} = +1 dBm/tone, Δf = 1 MHz	+29	+34		dBm
Input Impedance	Differential		100		ohm
Noise Figure	Input Balun and PCB trace losses deducted		1.8		dB
Device Current, ON	V _{PD} = 0.63 V		70	110	mA
Device Current, OFF	V _{PD} = 1.17 V		4		mA
V _{PD} , Logic Low		0		0.63	V
V _{PD} , Logic High		1.17		V _{DD}	V
I _{PD} , Control Current	V _{PD} Logic High		150		μA
Switching Time	50% DC to 10/90% RF		100		nsec
Thermal Resistance, θ _{Jc}	Junction to case		50		°C/W

Notes:

1. Test conditions unless otherwise noted: V_{DD} = +5.0 V, V_{PD} = +0.63 V, I_{DD} = 70 mA, Temp = +25 °C, 50 Ω system.
2. Calculated or converted from 3 port S-Parameter measurement, and assuming an ideal Balun at differential port.

Logic Table

Parameter, V _{PD}	High	Low
Device State	OFF	ON

3300 to 5000MHz Evaluation Board - QPA9133EVB-01

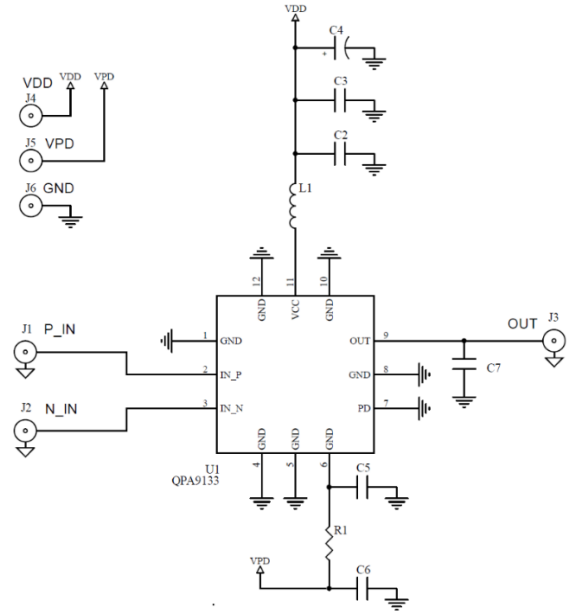
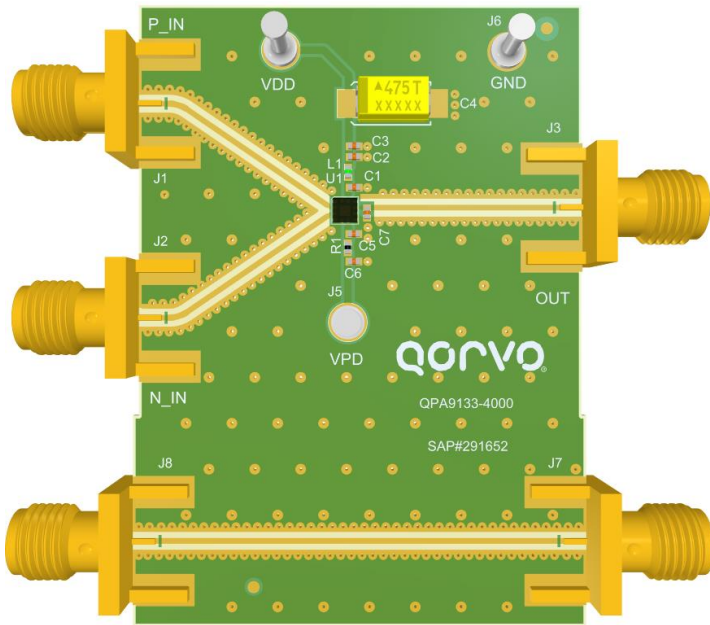

Bill of Materials

Reference Des.	Value	Description	Manuf.	Part Number
PCB	-	Printed Circuit Board	Qorvo	291652
U1	-	AMP, Differential Input Gain Block	Qorvo	QPA9133
C2	1000 pF	CAP, 1000 pF, 10%, 50V, X7R, 0402	Various	
C3	0.1 μF	CAP, 0.1 μF, 10%, 50V, X5R, 0402	Various	
C4	10 μF	CAP, 10 μF, 20%, 25V, Tantalum, 6032	Cal-Chip	TCMIE106CT
C7	0.2 pF	CAP, 0.2 pF, ±0.1pF, 50V, Hi-Q, 0402	Murata	GJM1555C1HR20BB01D
L1	2 nH	IND, 2 nH, ±0.1 nH, Thin Film, 0402	Murata	LQP15MN2N0B02D
R1	0 Ω	RES, 0 Ω, 1/10W, 0402	Various	
J1, J2, J3	-	CONN, SMA F STRT .062"	Cinch	142-0701-851

Typical Performance – QPA9133EVB-01

Parameter	Conditions ⁽¹⁾	Typical Value							Units
		3300	3500	3600	3800	4500	4800	5000	
Frequency									MHz
Gain ⁽²⁾	Small signal	19.9	20.3	20.5	20.8	21.8	21.6	20.6	dB
Input Return Loss ⁽²⁾		12.8	14.5	15.1	14.3	7.9	8.4	9.8	dB
Output Return Loss		8.6	8.3	8.0	7.6	8.5	7.4	4.8	dB
Noise Figure	Balun & PCB trace lose excluded	1.61	1.69	1.70	2.00	1.95	1.97	2.06	dB
Output P1dB		19.9	19.3	19.0	18.8	16.5	16.5	16.5	dBm
Output IP3	Pout = -1 dBm/tone, Δf = 1 MHz	35.8	34.5	35.3	34.2	32.5	32.2	32.0	dBm

Notes:

1. Test conditions unless otherwise noted: V_{DD} = +5.0V, V_{PD} = +0.63V, I_{DD} = 70 mA, V_{PD} = +0.63V, Temp = +25 °C, 50 Ω system.
2. Calculated or converted from 3 port S-Parameter measurement, and assuming an ideal Balun at differential port.

Performance Plots⁽¹⁾ – QPA9133EVB-01

Test conditions unless otherwise noted: $V_{DD} = +5V$, $V_{PD} = +0.63V$, $I_{DQ} = 70\text{ mA}$, Temp. = +25 °C

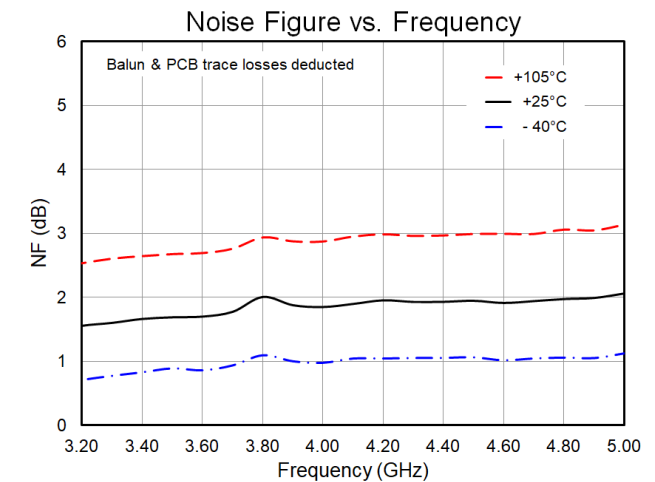
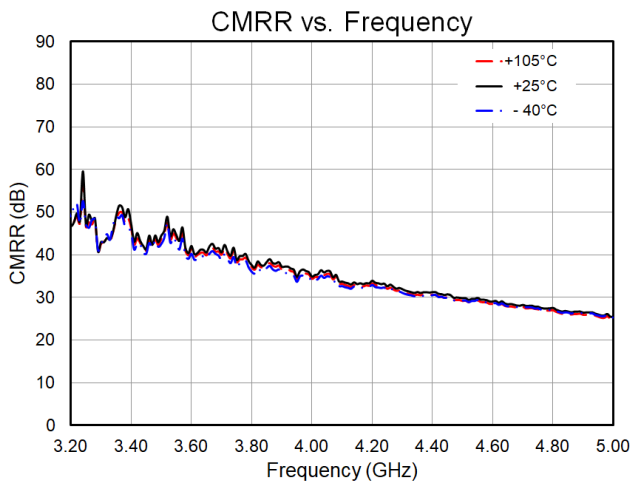
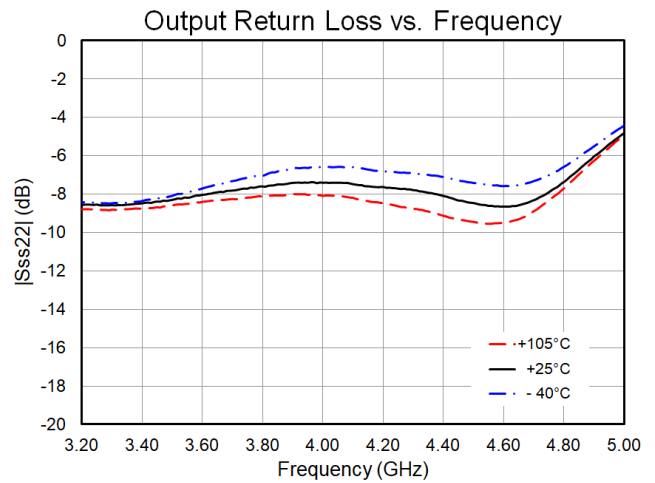
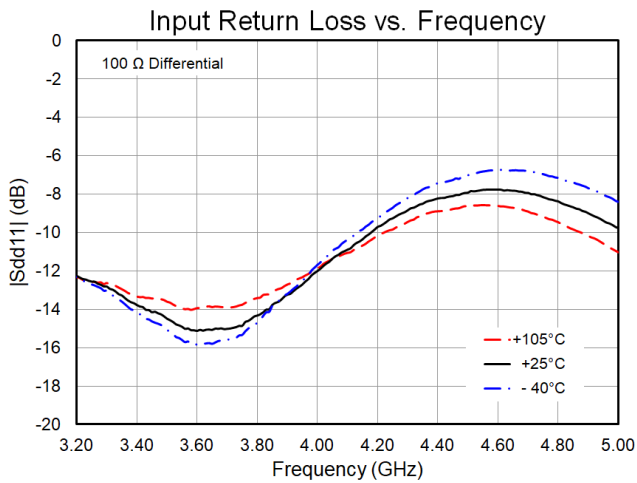
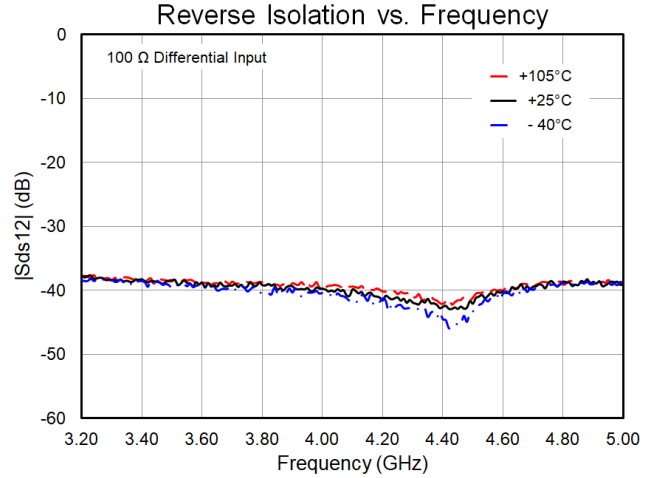
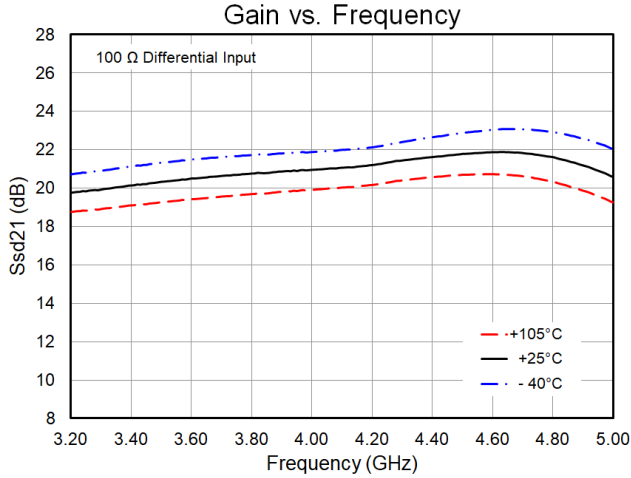

Note:

1. Differential related s-parameters converted or calculated from 3 port measurement, and assuming an ideal Balun at differential port.

Performance Plots – QPA9133EVB-01 (Continued)

Test conditions unless otherwise noted: $V_{DD} = +5V$, $V_{PD} = +0.63V$, $I_{DQ} = 70\text{ mA}$, $Temp. = +25\text{ }^\circ\text{C}$

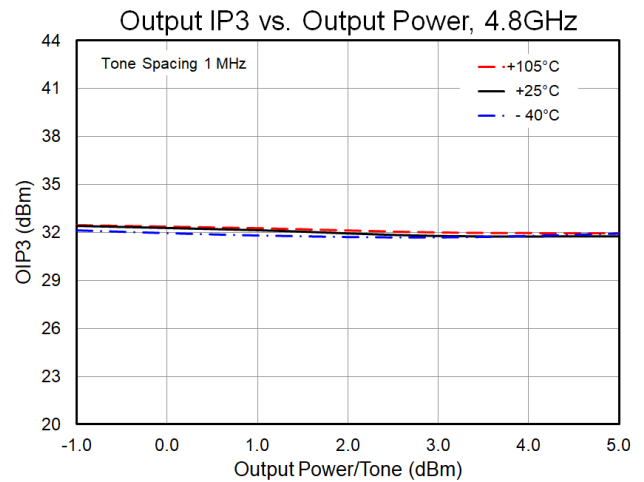
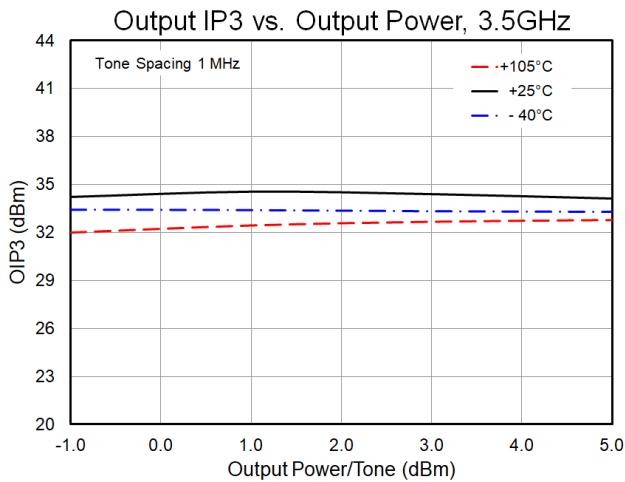
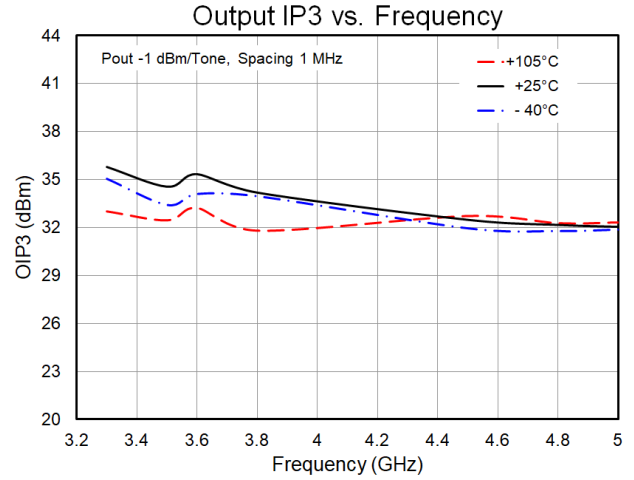
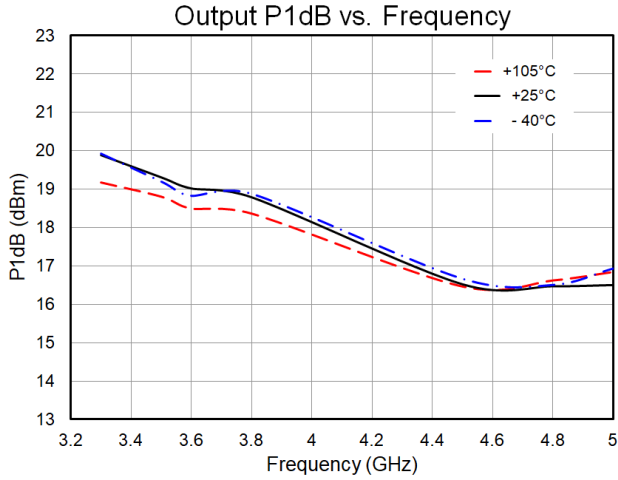

3300 to 5000MHz Evaluation Board with Balun

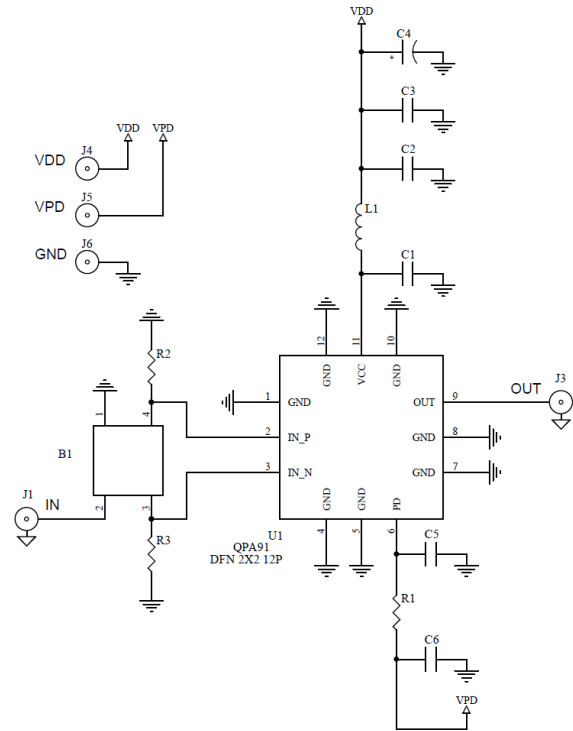

Bill of Materials, EVB with Balun

Reference Des.	Value	Description	Manuf.	Part Number
PCB	-	Printed Circuit Board	Qorvo	289725
U1	-	AMP, Differential Input Gain Block	Qorvo	QPA9133
B1	-	BALUN, 100 Ω Differential / 50 Ω Single Ended	Anaren	BD3150N50100AHF
C2	1000 pF	CAP, 1000 pF, 10%, 50V, X7R, 0402	Various	-
C3	0.1 μF	CAP, 0.1 μF, 10%, 50V, X5R, 0402	Various	-
C4	10 μF	CAP, 10 μF, 20%, 25V, Tantalum, 6032	Cal-Chip	TCMIE106CT
C7	0.2 pF	CAP, 0.2 pF, ±0.1pF, 50V, Hi-Q, 0402	Murata	GJM1555C1HR20BB01D
L1	2 nH	IND, 2 nH, ±0.1 nH, Thin Film, 0402	Murata	LQP15MN2N0B02D
R1	0 Ω	RES, 0 Ω, 1/10W, 0402	Various	-
J1, J3	-	CONN, SMA F STRT .062"	Cinch	142-0701-851

Pad Configuration and Description

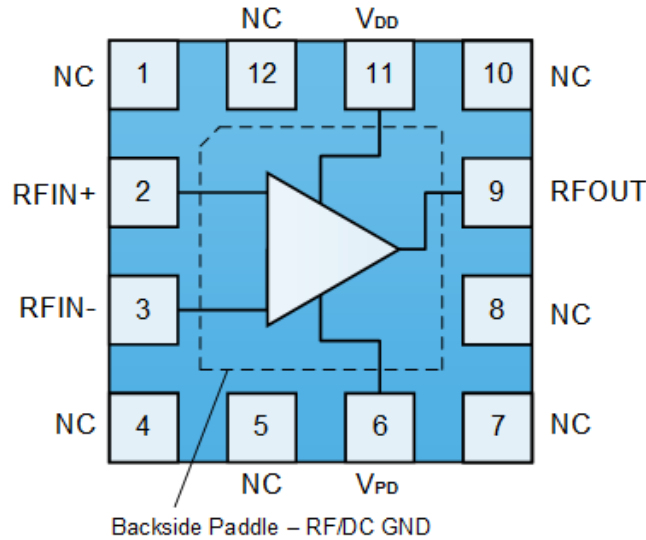

Top View

Pad No.	Label	Description
1, 3, 4, 5, 7, 10, 12	NC	Pads with no electrical connection internally. It may be left floating or connected to ground. Land pads should be provided for PCB mounting integrity.
2	RFIN+	Positive end of the differential input. External DC blocking capacitor required if DC is present.
3	RFIN-	Negative end of the differential input. External DC blocking capacitor required if DC is present.
6	V _{PD}	Control input. Amplifier ON or OFF
9	RFIN	RF output. Internally matched to 50 ohms.
11	V _{DD}	DC voltage input. Power supply for amplifier. RF choke required.
Center Ground Pad	-	DC and RF ground. Via holes required for DC, RF and thermal conductivity.

Package Marking and Dimensions

Marking: Part Number – 9133
Trace Code – XXXX up to 4 Characters assigned by sub-contractor

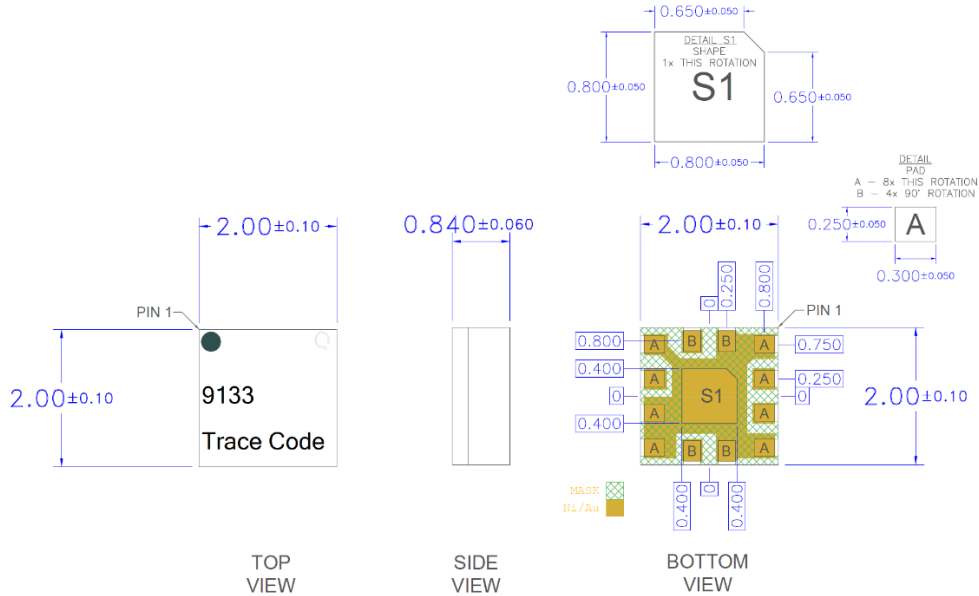

- Notes:
1. All dimensions are in millimeters. Angles are in degrees.
 2. The terminal #1 identifier and terminal numbering conform to SPE-000677.

Recommended PCB Layout Pattern

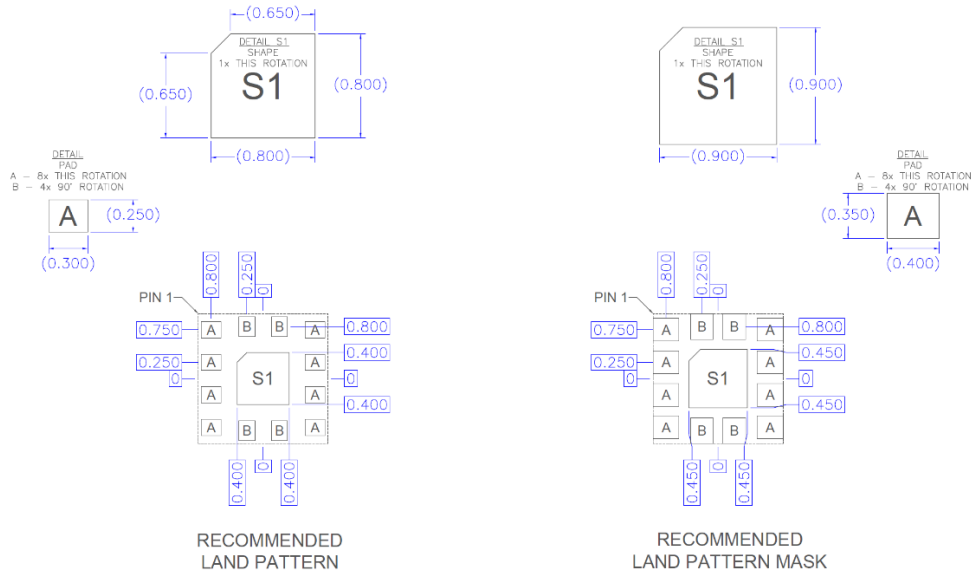

- Notes:
1. All dimensions are in millimeters. Angles are in degrees.
 2. Use 0.5 oz. copper minimum for top and bottom layer metal.
 3. Via holes are required under the backside paddle of this device for proper RF/DC grounding and thermal dissipation. We recommend a 0.35mm (#80/.0135") diameter bit for drilling via holes and a final plated thru diameter of 0.25 mm (0.01").
 4. Ensure good package backside paddle solder attach for reliable operation and best electrical performance.

Tape and Reel Information – Carrier and Cover Tape Dimensions

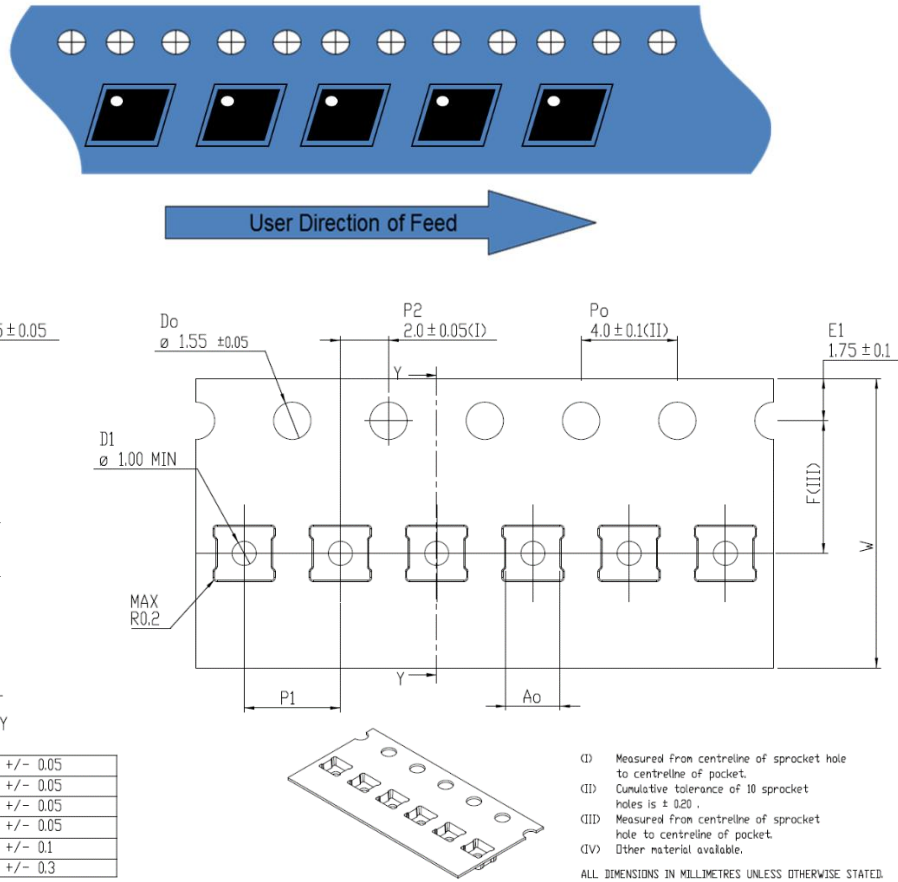

Ao	2.20 +/- 0.05
Bo	2.20 +/- 0.05
Ko	0.95 +/- 0.05
F	5.50 +/- 0.05
P1	4.00 +/- 0.1
W	12.00 +/- 0.3

Feature	Measure	Symbol	Size (in)	Size (mm)
Cavity	Length	A0	0.087	2.20
	Width	B0	0.087	2.20
	Depth	K0	0.037	0.95
	Pitch	P1	0.157	4.00
Centerline Distance	Cavity to Perforation - Length Direction	P2	0.079	2.00
	Cavity to Perforation - Width Direction	F	0.217	5.50
Cover Tape	Width	C	0.362	9.20
Carrier Tape	Width	W	0.472	12.0

Tape and Reel Information – Reel Dimensions (7")

Standard T/R size = 2,500 pieces on a 7" reel.

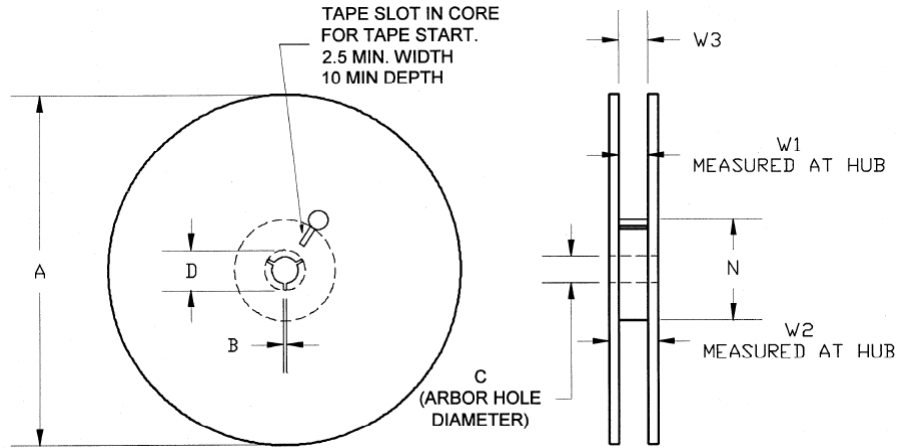

Feature	Measure	Symbol	Size (in)	Size (mm)
Flange	Diameter	A	6.969	177.0
	Thickness	W2	0.717	18.2
	Space Between Flange	W1	0.504	12.8
Hub	Outer Diameter	N	2.283	58.0
	Arbor Hole Diameter	C	0.512	13.0
	Key Slit Width	B	0.079	2.0
	Key Slit Diameter	D	0.787	20.0

Tape and Reel Information – Tape Length and Label Placement

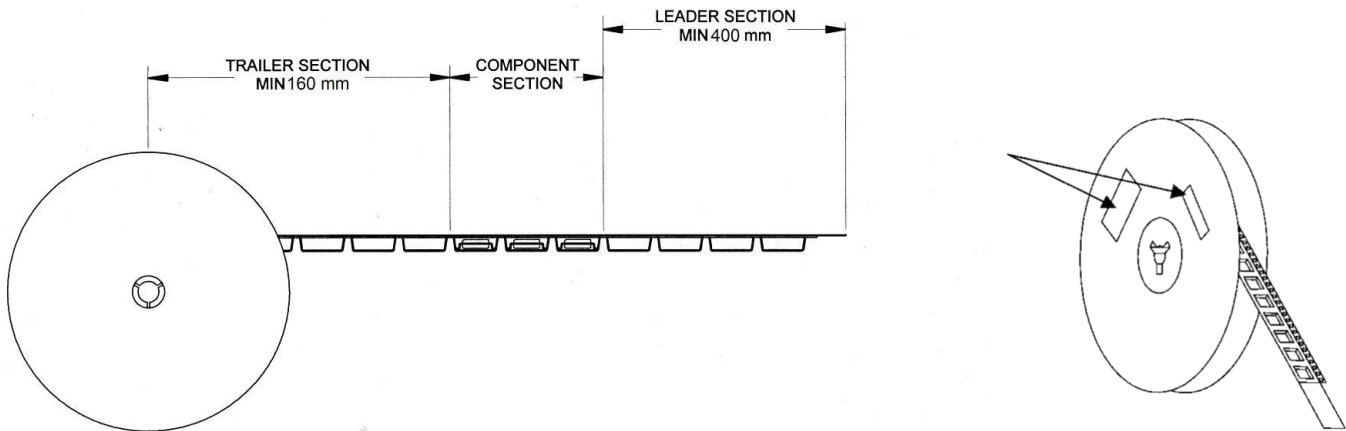

- Notes:
1. Empty part cavities at the trailing and leading ends are sealed with cover tape. See EIA 481-1-A.
 2. Labels are placed on the flange opposite the sprockets in the carrier tape.

Handling Precautions

Parameter	Rating	Standard
ESD – Human Body Model (HBM)	Class 1C	ESDA / JEDEC JS-001-2017
ESD – Charged Device Model (CDM)	Class C3	JEDEC JESD22-C101F
MSL – Moisture Sensitivity Level	Level 3	IPC/JEDEC J-STD-020E



Caution!
ESD-Sensitive Device

Solderability

Compatible with both lead-free (260°C max. reflow temperature) and tin/lead (245°C max. reflow temperature) soldering processes. Solder profiles available upon request.

Contact plating: ENEPIG

RoHS Compliance

This part is compliant with 2011/65/EU RoHS directive (Restrictions on the Use of Certain Hazardous Substances in Electrical and Electronic Equipment) as amended by Directive 2015/863/EU.

This product also has the following attributes:

- Lead Free
- Halogen Free (Chlorine, Bromine)
- Antimony Free
- TBBP-A (C₁₅H₁₂Br₄O₂) Free
- SVHC Free



Contact Information

For the latest specifications, additional product information, worldwide sales and distribution locations:

Web: www.qorvo.com

Tel: 1-844-890-8163

Email: customer.support@qorvo.com

Important Notice

The information contained herein is believed to be reliable; however, Qorvo makes no warranties regarding the information contained herein and assumes no responsibility or liability whatsoever for the use of the information contained herein. All information contained herein is subject to change without notice. Customers should obtain and verify the latest relevant information before placing orders for Qorvo products. The information contained herein or any use of such information does not grant, explicitly or implicitly, to any party any patent rights, licenses, or any other intellectual property rights, whether with regard to such information itself or anything described by such information. **THIS INFORMATION DOES NOT CONSTITUTE A WARRANTY WITH RESPECT TO THE PRODUCTS DESCRIBED HEREIN, AND QORVO HEREBY DISCLAIMS ANY AND ALL WARRANTIES WITH RESPECT TO SUCH PRODUCTS WHETHER EXPRESS OR IMPLIED BY LAW, COURSE OF DEALING, COURSE OF PERFORMANCE, USAGE OF TRADE OR OTHERWISE, INCLUDING THE IMPLIED WARRANTIES OF MERCHANTABILITY AND FITNESS FOR A PARTICULAR PURPOSE.**

Without limiting the generality of the foregoing, Qorvo products are not warranted or authorized for use as critical components in medical, life-saving, or life-sustaining applications, or other applications where a failure would reasonably be expected to cause severe personal injury or death.

Copyright 2020 © Qorvo, Inc. | Qorvo is a registered trademark of Qorvo, Inc.

X-ON Electronics

Largest Supplier of Electrical and Electronic Components

Click to view similar products for [RF Amplifier](#) category:

Click to view products by [Qorvo](#) manufacturer:

Other Similar products are found below :

[A82-1](#) [BGA622H6820XTSA1](#) [BGA 728L7 E6327](#) [BGB719N7ESDE6327XTMA1](#) [HMC397-SX](#) [HMC405](#) [HMC561-SX](#) [HMC8120-SX](#)
[HMC8121-SX](#) [HMC-ALH382-SX](#) [HMC-ALH476-SX](#) [SE2433T-R](#) [SMA3101-TL-E](#) [SMA39](#) [A66-1](#) [A66-3](#) [A67-1](#) [A81-2](#) [LX5535LQ](#)
[LX5540LL](#) [MAAM02350](#) [HMC3653LP3BETR](#) [HMC549MS8GETR](#) [HMC-ALH435-SX](#) [SMA101](#) [SMA32](#) [SMA411](#) [SMA531](#)
[SST12LP19E-QX6E](#) [WPM0510A](#) [HMC5929LS6TR](#) [HMC5879LS7TR](#) [HMC1126](#) [HMC1087F10](#) [HMC1086](#) [HMC1016](#) [SMA1212](#)
[MAX2689EWS+T](#) [MAAMSS0041TR](#) [MAAM37000-A1G](#) [LTC6430AIUF-15#PBF](#) [SMA70-2](#) [SMA4011](#) [A231](#) [HMC-AUH232](#) [LX5511LQ](#)
[LX5511LQ-TR](#) [HMC7441-SX](#) [HMC-ALH310](#) [XD1001-BD-000V](#)