

Product Overview

The QPB8896 is a GaAs pHEMT RF balanced amplifier IC operating as return path amplifier capable of supporting DOCSIS 4.0 applications. This IC is designed to provide a low noise, high gain option for 5 – 700 MHz interface using a 5V power supply to provide lower overall power dissipation. QPB8896 is in a convenient SOIC-8 package.



SOIC-8 with Exposed Pad

Functional Block Diagram

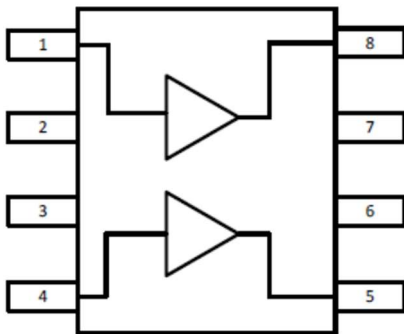

Functional Block Diagram

Top View

Key Features

- 5 MHz to 700 MHz Operation
- 5 V Operation
- High Gain: 25 dB Typical
- Low Noise Figure:
 - 1.1dB for Upstream Splits Through 492MHz
 - 1.8dB for 684MHz
- SOIC-8 Exposed Pad

Applications

- Head End CMTS Equipment
- Post Amp for Return Path Optical Receivers
- Full Duplex Upstream
- DOCSIS 4.0 Optical Nodes
- DOCSIS 4.0 Amplifiers

Ordering Information

Part Number	Description
QPB8896SR	7" Reel with 100 pieces
QPB8896TR13	13" Reel with 2500 pieces
QPB8896PCK	5 – 700 MHz PCBA with 5 pc sample bag
QPB8896PCK-1	5 – 300 MHz PCBA with 5 pc sample bag

Absolute Maximum Ratings

Parameter	Rating
Supply Voltage (V _{DD})	+8 V
Supply Current (I _{DD})	360 mA
Maximum CW Input Power for V _{DD} = 5 V	+1 dBm
Operating Temperature Range	-40 to +85 °C
Storage Temperature Range	-40 to +150 °C
Maximum Junction Temperature	+160 °C

Exceeding any one or a combination of the Absolute Maximum Rating conditions may cause permanent damage to the device. Extended application of Absolute Maximum Rating conditions to the device may reduce device reliability.

Electrical Specifications; 5-700MHz

Parameter	Condition ⁽¹⁾	Min	Typ	Max	Unit
Supply Voltage (V _{DD})			5		V
Supply Current (I _{DD})			275		mA
Frequency Range		5		700	MHz
Gain	Full Bandwidth		25.0		dB
Gain Flatness	Max. deviation from line using least squares fit from 5 to 700 MHz		±0.5		dB
Gain Tilt	Gain (700 MHz) – Gain (5 MHz)		-0.1		dB
Input Return Loss	5 MHz		33		dB
	125 MHz		26		dB
	300 MHz		20		dB
	700 MHz		16		dB
Output Return Loss	5 MHz		20		dB
	125 MHz		22		dB
	300 MHz		18		dB
	700 MHz		16.5		dB
Reverse Isolation			30		dB
Noise Figure	(includes balun loss)		1.8		dB
ACLR	P _{out} = 62 dBmV, 5 – 195 MHz OFDM w/ 9.6 MHz exclusion band.		59.7		dB
DTO	f ₁ =13 MHz, f ₂ =19 MHz 58.75 dBmV/tone		-62		dBc
DSO	f ₁ =13 MHz, f ₂ =19 MHz 58.75 dBmV/tone		-60		dBc
OIP2	5 – 700 MHz 2-Tone, 6 MHz spacing 3 dBm/tone		70		dBm
OIP3	5 – 700 MHz 2-Tone, 6 MHz spacing 5 dBm/tone		38		dBm
Output P1dB	Full Band		22.6		dBm
Thermal Resistance	Θ _{JC}		23		°C/W

Notes:

1. Typical performance at these conditions: Temp = +25 °C, V_{DD} = +5 V, 75 Ω system

Evaluation Board Schematic; QPB8896-4000 EVB (5 – 700 MHz)

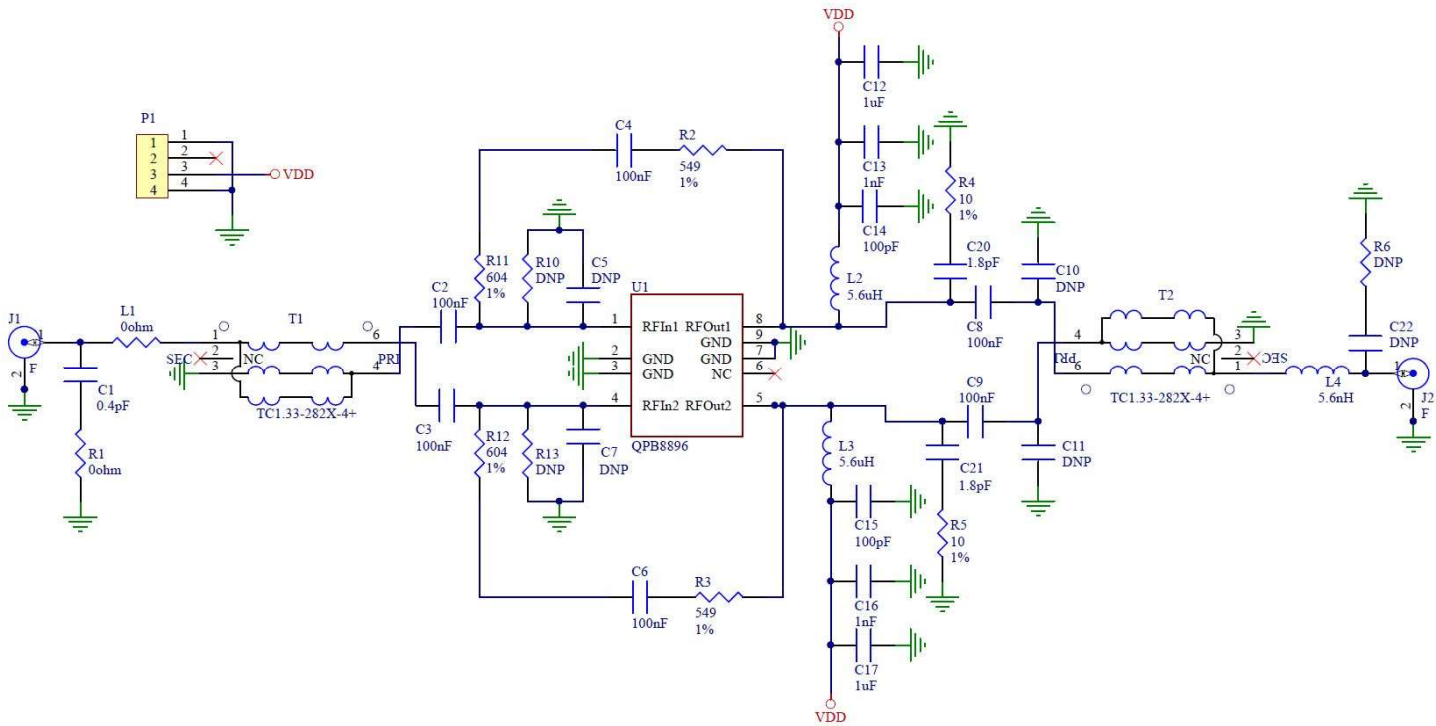



QPB8896

25 dB Balanced Return Path Amplifier (5 – 700 MHz)

Evaluation Board Bill of Materials; QPB8896-4000 (5 – 700 MHz)

Reference Designator	Description	Manufacturer	Part Number
PCB	QPB8896-4000	Viasystems	QPB8896-4000
U1	Balanced Return Path Amplifier, 5-700 MHz	Qorvo	QPB8896
C1	CAP, 0.4 pF, +/-0.05 pF, 50 V, C0G, 0402	Murata Electronics	GRM1555C1HR40WA01D
C13, C16	CAP, 1000 pF, 10 %, 50 V, X7R, 0402	Taiyo Yuden	RM UMK105BJ102KV-F
C4, C6	CAP, 0.1 uF, 10 %, 16 V, X7R, 0402	Murata Electronics	GRM155R71C104KA88D
C2, C3, C8, C9	CAP, 0.1 uF, 10 %, 16 V, X7R, 0603	Murata Electronics	GRM188R71C104KA01D
C20, C21	CAP, 1.8 pF, +/-0.1 pF, 50 V, C0G, 0402	Murata Electronics	GRM1555C1H1R8BA01E
C12, C17	CAP, 1 uF, 10 %, 16 V, X7R, 0603	Murata Electronics	GRM188R71C105KA12D
C14, C15	CAP, 100 pF, 5 %, 50 V, C0G, 0402	Taiyo Yuden	RM UMK105CG101JV-F
L2, L3	IND, 5.6 uH, 5 %, W/W, 1008	Coilcraft, Inc.	1008LS-562XJLC
R2, R3	RES, 549 Ω , 1 %, 1/10 W, 0402	Kamaya, Inc	RMC1/16SK5490FTH
R11, R12	RES, 604 Ω , 1 %, 1/10 W, 0402	Kamaya, Inc	RMC1/16SK6040FTH
R4, R5	RES, 10 Ω , 1 %, 1/16 W, 0402	Panasonic Industrial Devices	ERJ-2RKF10R0X
R1, L1	RES, 0 Ω , 0402	Kamaya, Inc	RMC1/16SJPTH
L4	IND, 5.6 nH, +/-0.1 nH, M/L, 0402	Murata Electronics	LQG15HS5N6B02D
T1, T2	XFMR, 5-2800 MHz, 100-75 Ω	MiniCircuits	TC1.33-282X-4+
P1	CONN, HDR, ST, FRCTN LOCK, 4-PIN	Molex	22-23-2041
J1, J2	CONN, F FEM EDGE MOUNT, 75 Ω , 0.068"	Millimeter Wave, LLC	MW-846-C-DD-75
M1	HEATSINK BLOCK, 1.5 X 2.0 IN	Shenzhen Minxingda Automation	EEF-105441
S1-S4	SCREW, 2-56X3/16", SOCKET HEAD	McMaster-Carr Supply Co.	92196A076
C5, C7, C10, C11, C22, R6, R10, R13	Not Populated		

Evaluation Board Assembly Drawing; QPB8896-4000 (5 – 700 MHz)

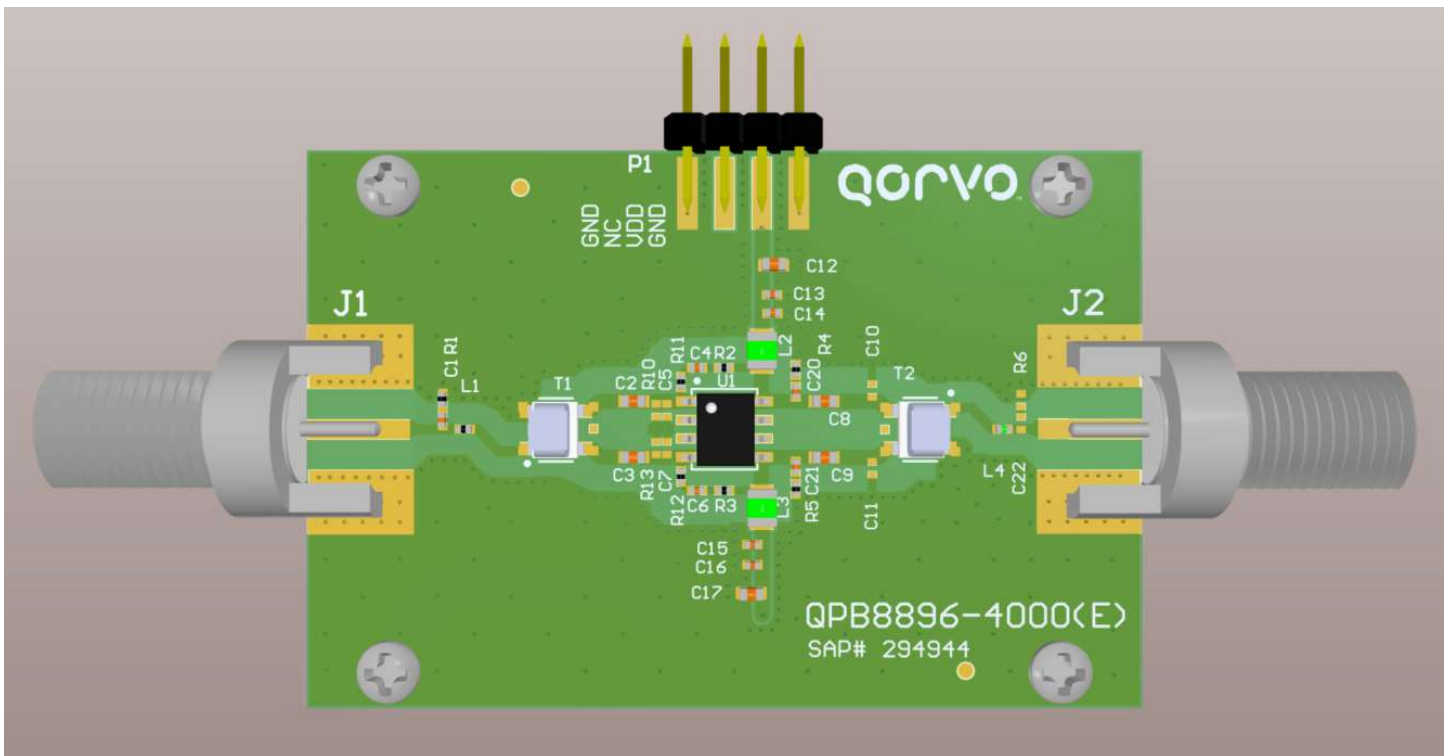

Typical Applications Schematic (5 – 700 MHz)

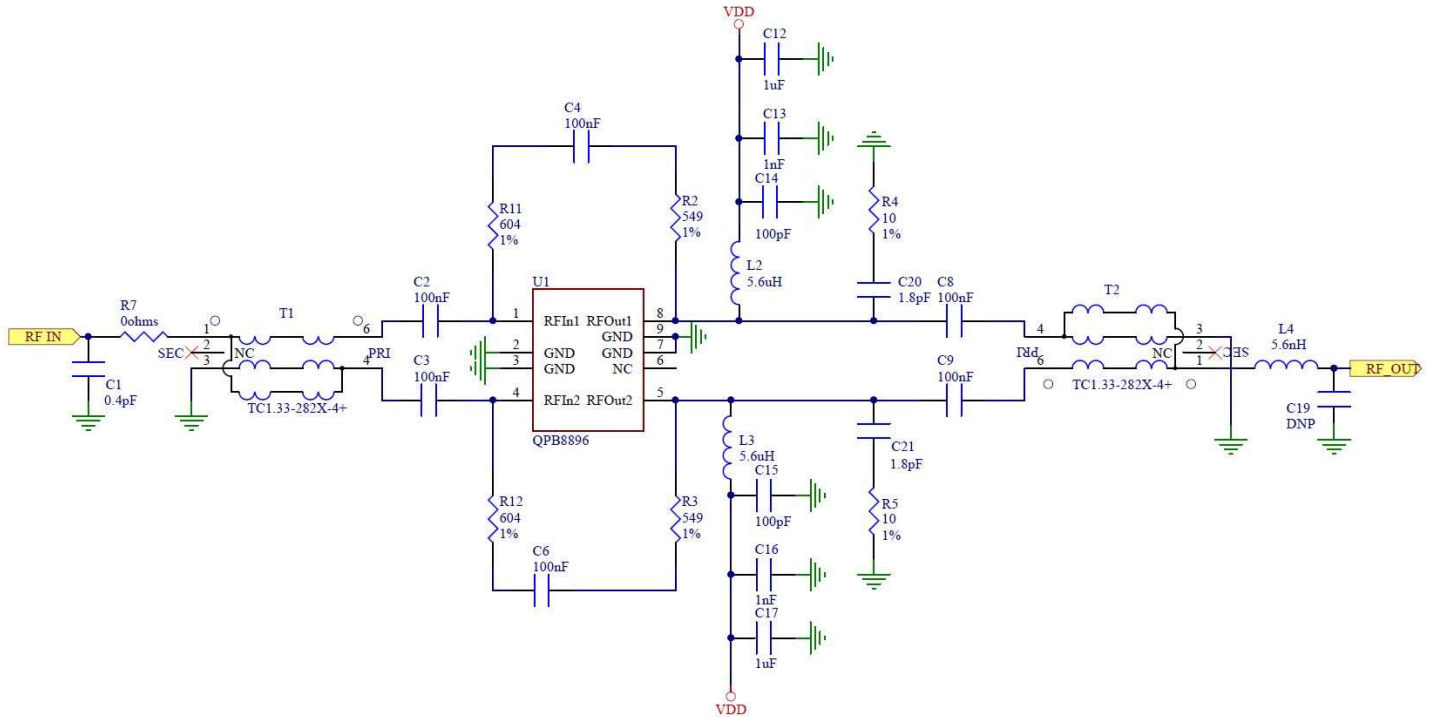

Notes:

1. C1-R7 tune to optimize input return loss.
2. L4-C19 tune to optimize output return loss.
3. Feedback R11/R2/C4 and R12/R3/C6 can be adjusted to balance gain flatness versus return loss and IMD performance.

Performance Data (5 – 700 MHz)

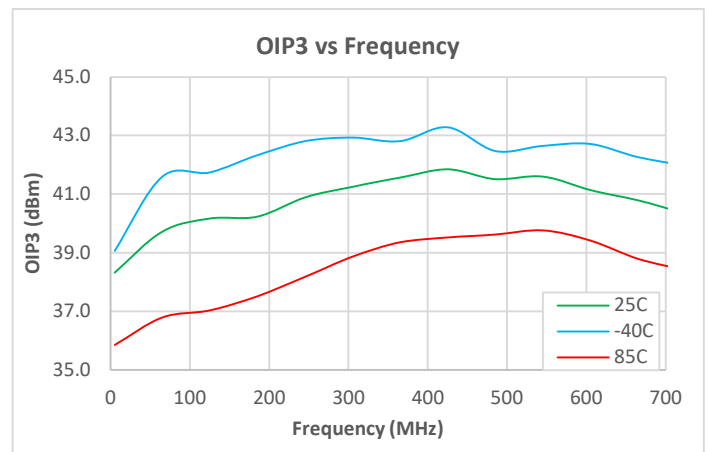
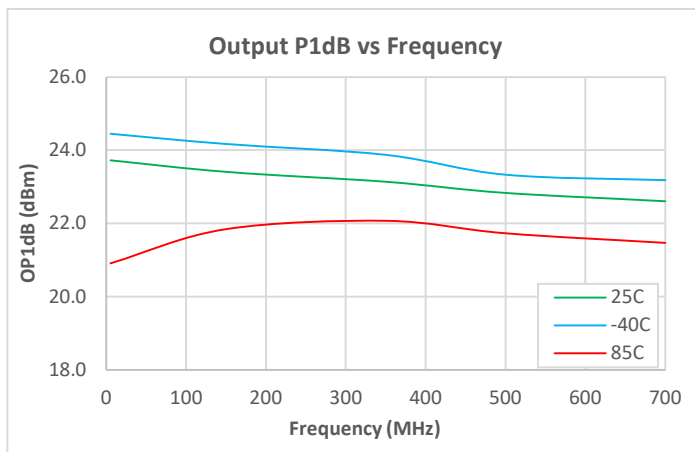
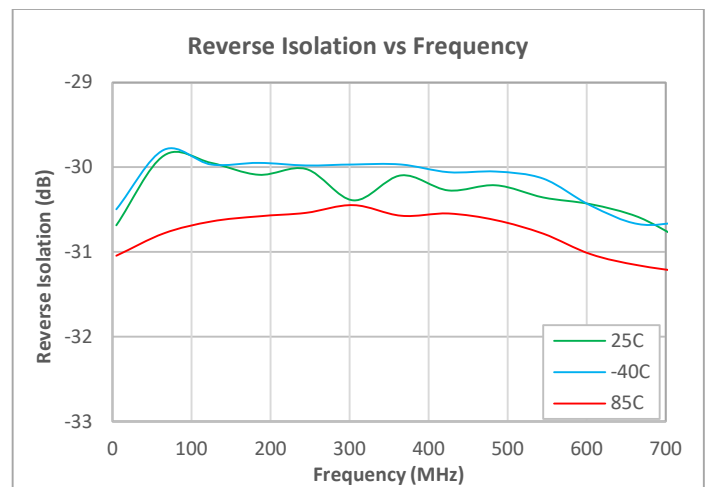
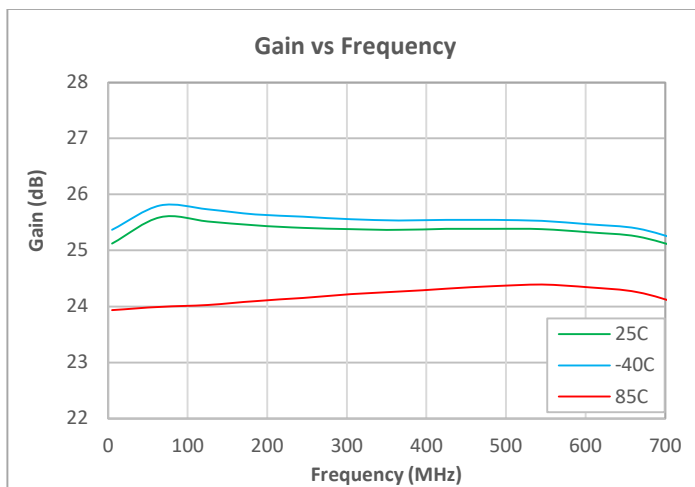
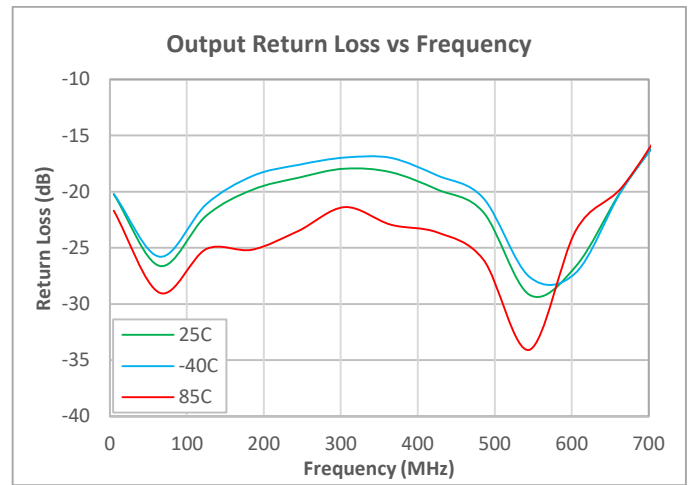
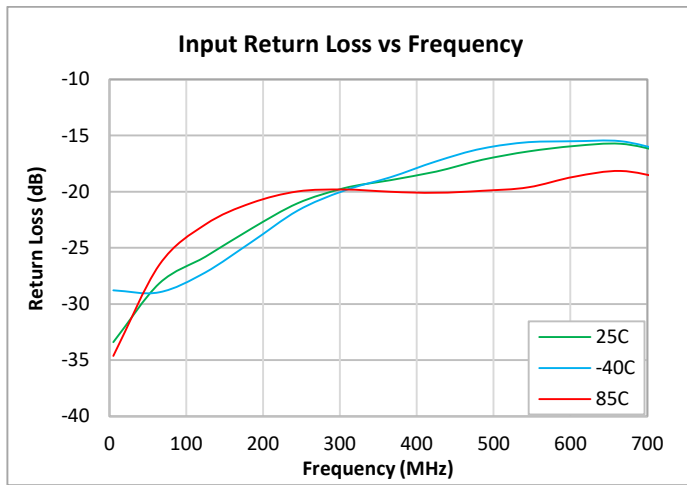

Notes:

- (1) OIP3: +5 dBm/tone, 6 MHz spacing

Performance Data (5 – 700 MHz)

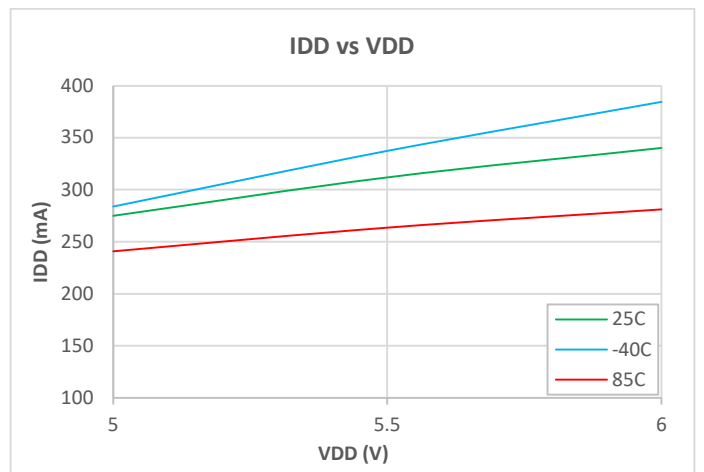
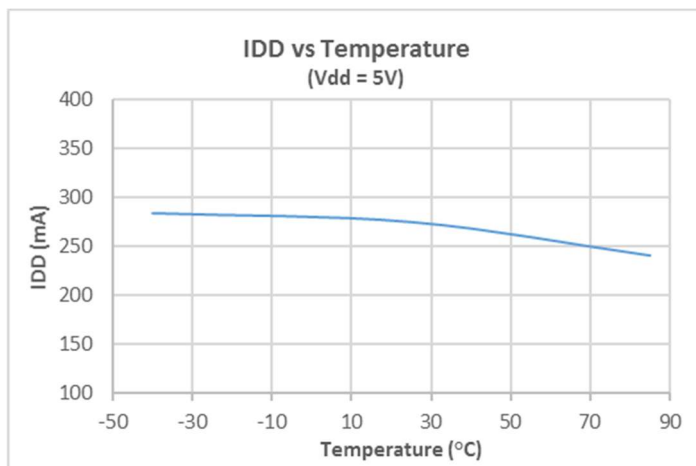
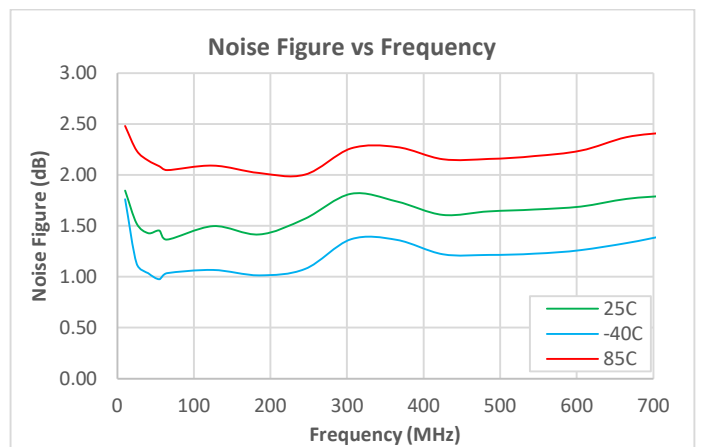
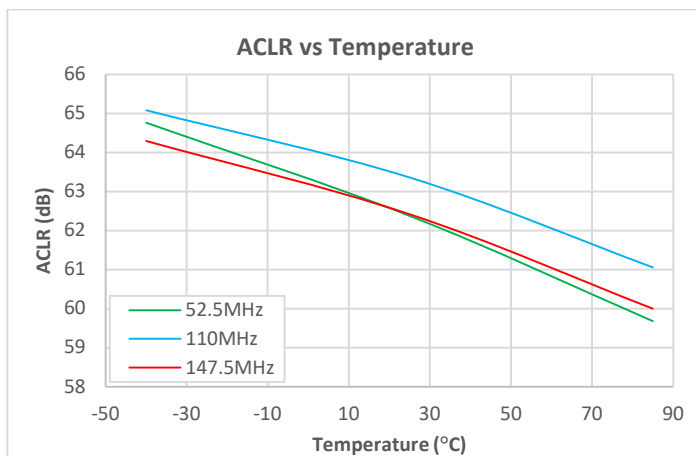
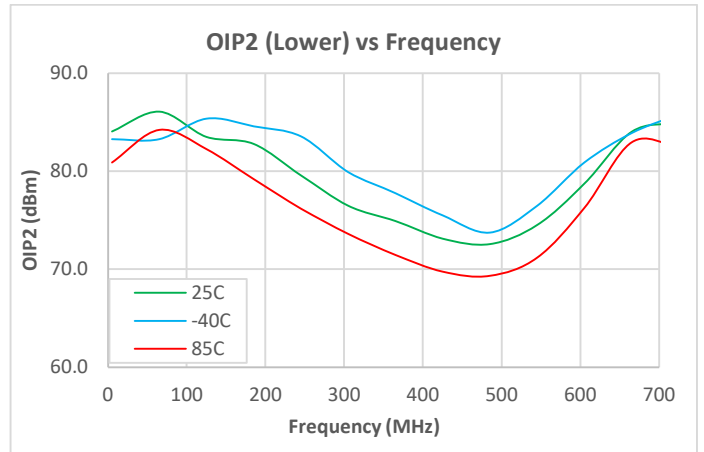
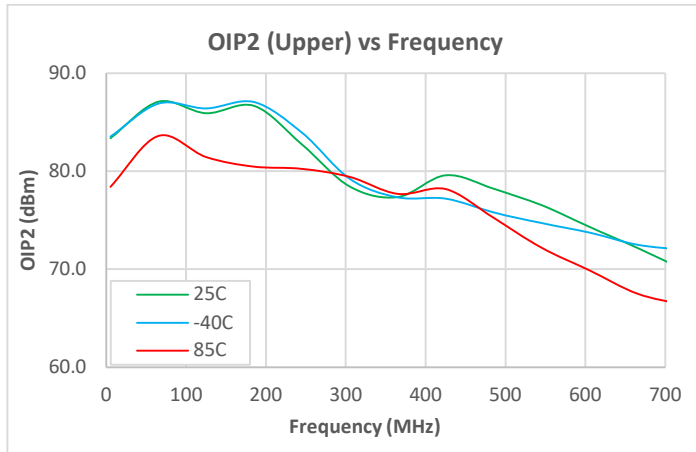

Notes:

- (1) OIP2: 3 dBm/tone, 6 MHz spacing
- (2) ACLR: P_{out} = 62 dBmV, 5-195 MHz OFDM w/ 9.6 MHz exclusion band.
- (3) IDD vs V_{DD}, -10 dBm input power at 125 MHz
- (4) IDD vs Temperature, -10 dBm input power at 125 MHz, V_{DD} = 5 V.

Performance Data (5 – 700 MHz)

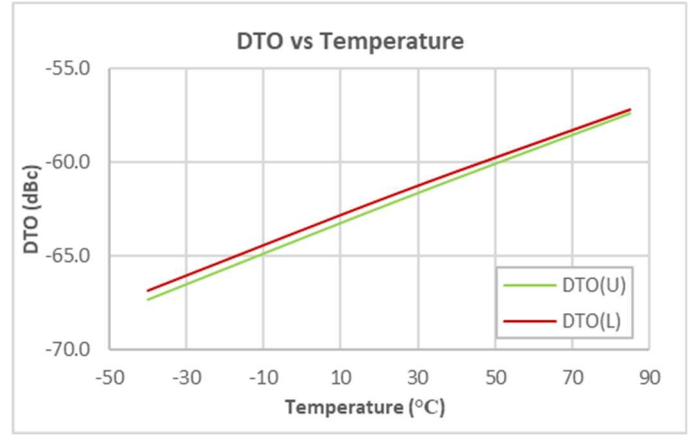
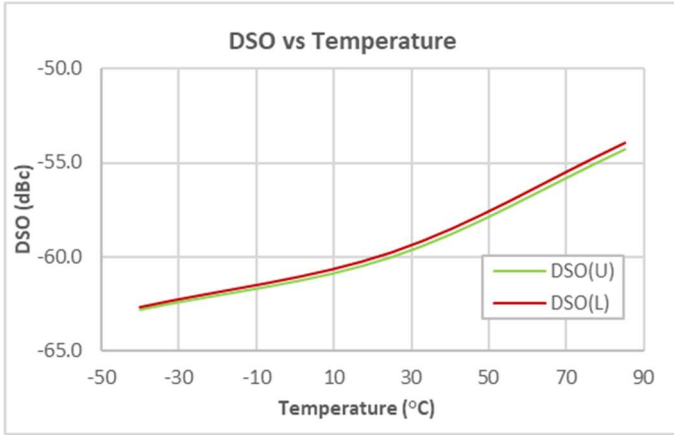

Notes:

- (1) DSO/DTO: f1=13 MHz, f2=19 MHz 58.75 dBmV per tone

Evaluation Board Schematic; QPB8896-4002 (5 – 300 MHz)

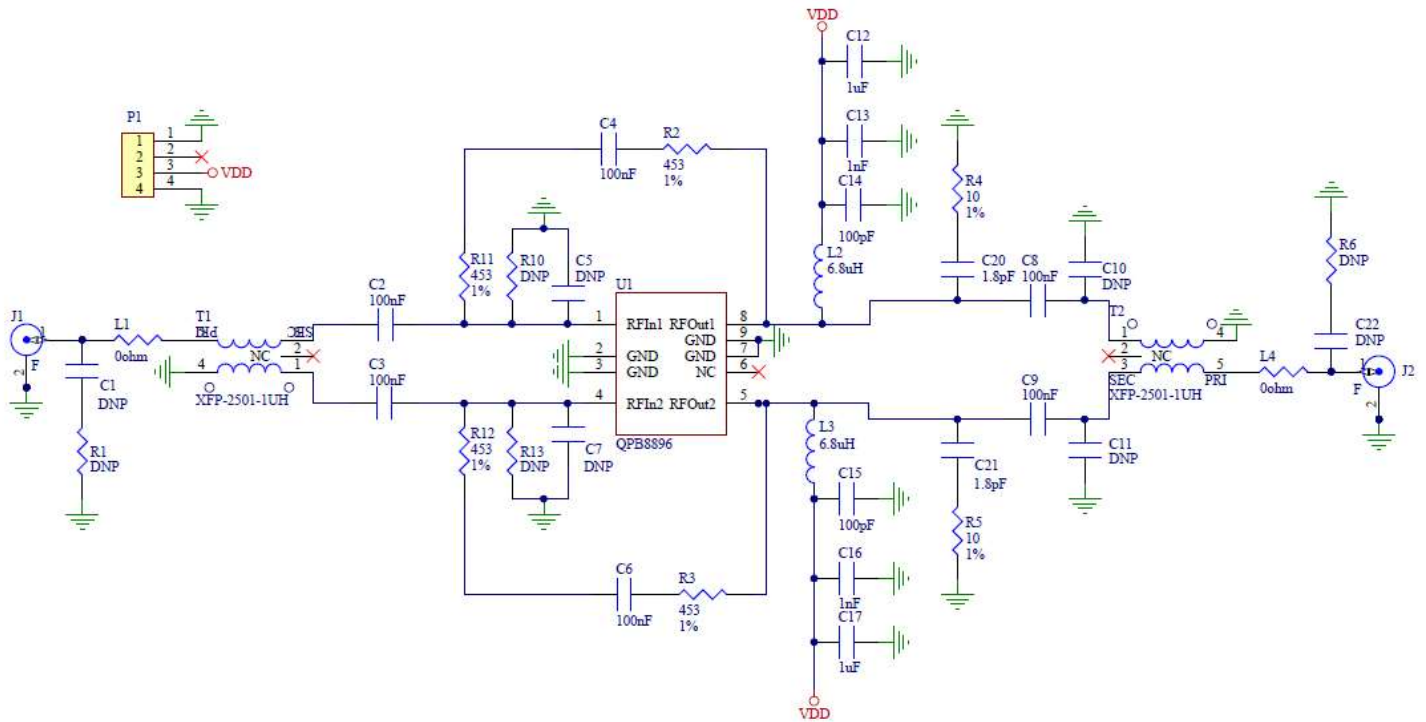



QPB8896

25 dB Balanced Return Path Amplifier (5 – 700 MHz)

Evaluation Board Bill of Materials for QPB8896-4002 (5 – 300 MHz)

Reference Designator	Description	Manufacturer	Part Number
PCB	QPB8896-4002	Viasystems	QPB8896-4002
U1	Balanced Return Path Amplifier, 5-700 MHz	Qorvo	QPB8896
C13, C16	CAP, 1000 pF, 10 %, 50 V, X7R, 0402	Taiyo Yuden	RM UMK105BJ102KV-F
C4, C6	CAP, 0.1 uF, 10 %, 16 V, X7R, 0402	Murata Electronics	GRM155R71C104KA88D
C2, C3, C8, C9	CAP, 0.1 uF, 10 %, 16 V, X7R, 0603	Murata Electronics	GRM188R71C104KA01D
C20, C21	CAP, 1.8 pF, +/-0.1 pF, 50 V, C0G, 0402	Murata Electronics	GRM1555C1H1R8BA01E
C12, C17	CAP, 1 uF, 10 %, 16 V, X7R, 0603	Murata Electronics	GRM188R71C105KA12D
C14, C15	CAP, 100 pF, 5 %, 50 V, C0G, 0402	Taiyo Yuden	RM UMK105CG101JV-F
L2, L3	IND, 6.8 uH, 5 %, W/W, 1008	Coilcraft, Inc.	1008LS-682XJLC
R2, R3, R11, R12	RES, 453 Ω , 1 %, 1/10 W, 0402	Panasonic	ERJ-2RKF4530X
R4, R5	RES, 10 Ω , 1 %, 1/16 W, 0402	Panasonic Industrial Devices	ERJ-2RKF10R0X
L1, L4	RES, 0 Ω , 0402	Kamaya, Inc	RMC1/16SJPTH
T1, T2	BALUN, 1:1, 1-2500 MHz, 75 Ω , SMD	MiniRF	XFP-2501-1UH
P1	CONN, HDR, ST, FRCTN LOCK, 4-PIN	Molex	22-23-2041
J1, J2	CONN, F FEM EDGE MOUNT, 75 Ω , 0.068"	Millimeter Wave , LLC	MW-846-C-DD-75
M1	HEATSINK BLOCK, 1.5 X 2.0 IN	Shenzhen Minxingda Automation	EEF-105441
S1-S4	SCREW, 2-56 X 3/16", SOCKET HEAD	McMaster-Carr Supply Co.	92196A076
C1, C5, C7, C10, C11, C22, R1, R6, R10, R13	Not Populated		

Evaluation Board Assembly Drawing for QPB8896-4002 (5 – 300 MHz)

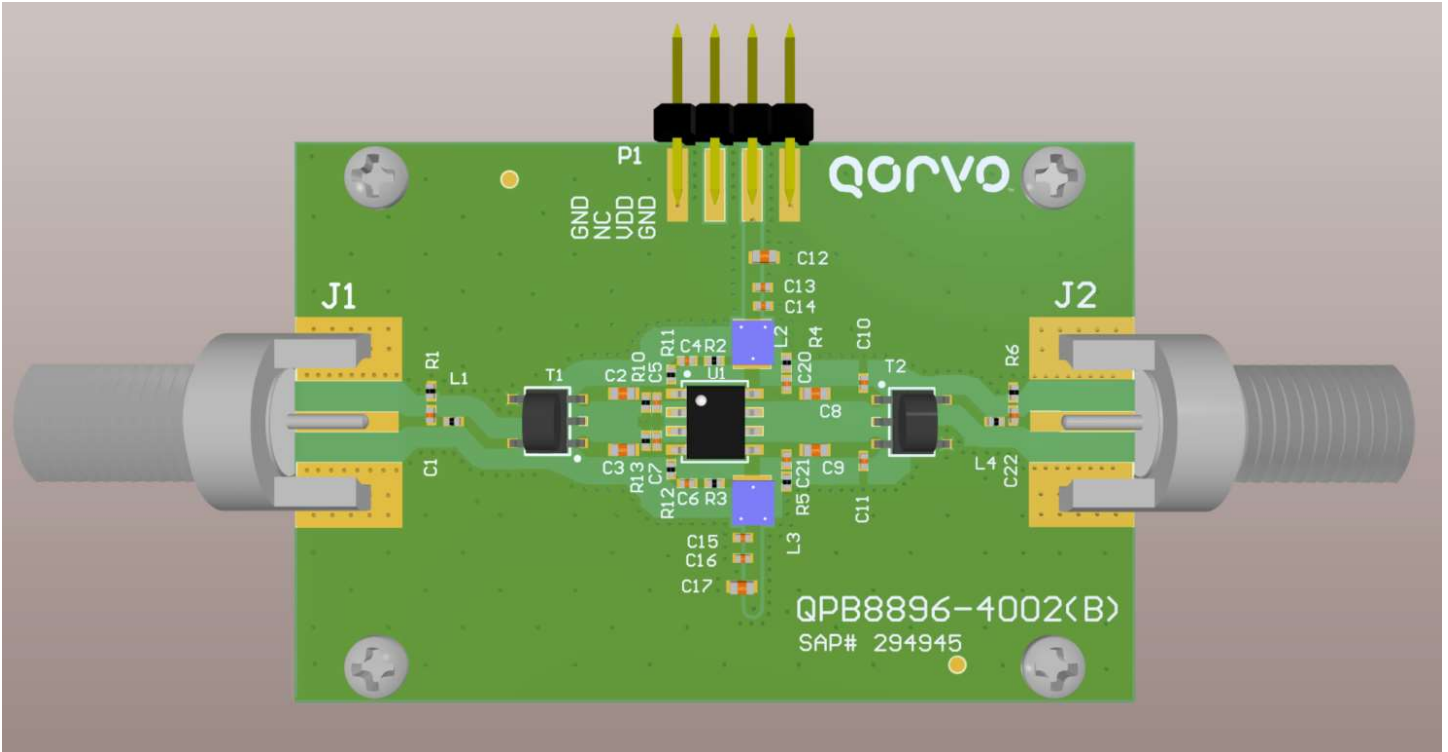

Typical Applications Schematic (5 – 300 MHz)

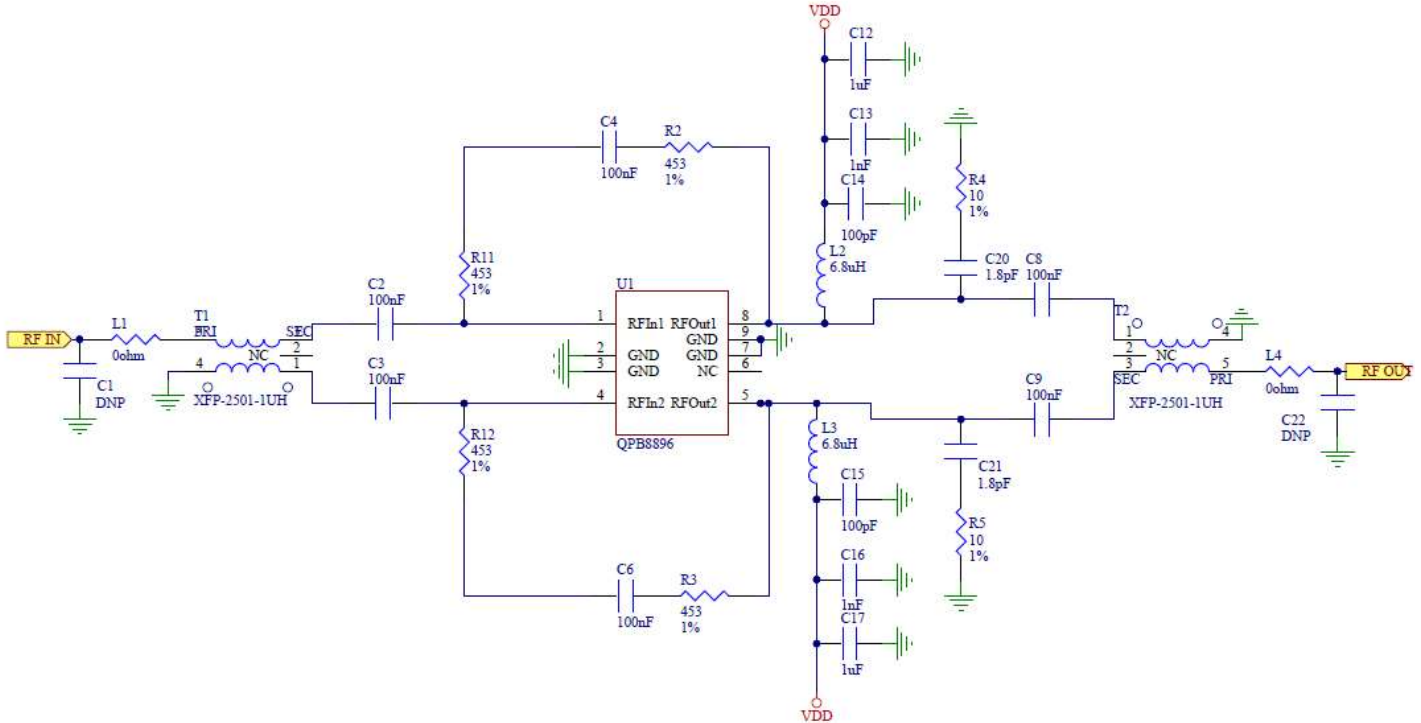

Notes:

1. Low insertion loss 1:1 baluns help reduce noise figure ≤ 1.1 dB
2. Optimal bandwidth with 1:1 baluns is 5 to 500MHz. 1.33:1 ratio baluns provide an easier path to matching for bandwidths beyond 500MHz.
3. C1-L1 tune to optimize input return loss.
4. L4-C22 tune to optimize output return loss.
5. Feedback R11/R2/C4 and R12/R3/C6 can be adjusted to balance gain flatness versus return loss and IMD performance.

Performance Data (5 – 300 MHz)

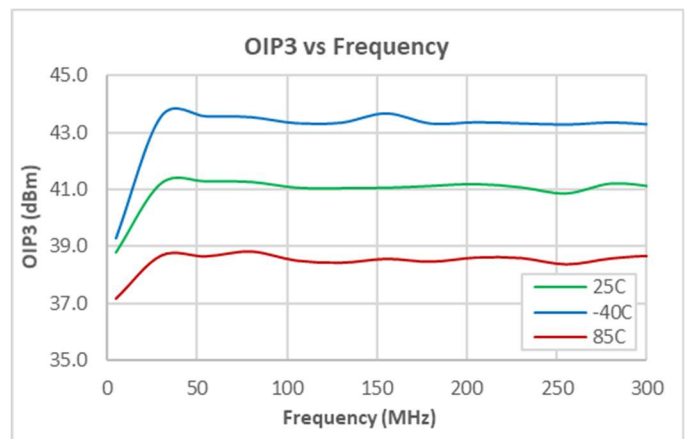
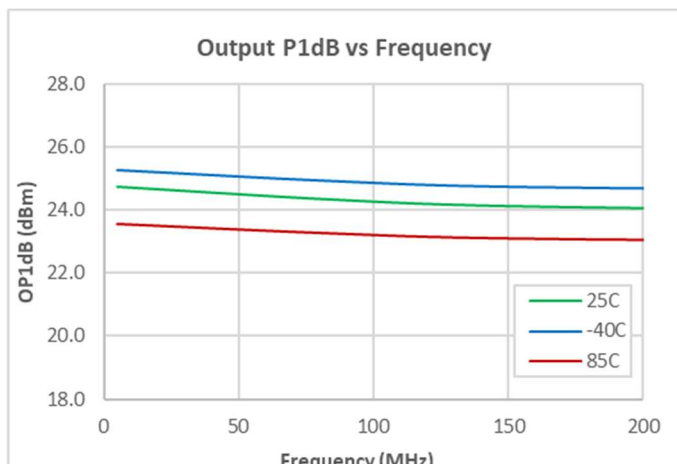
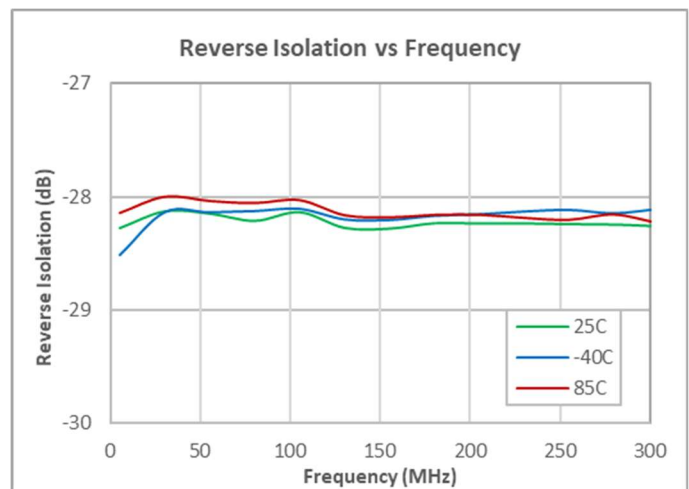
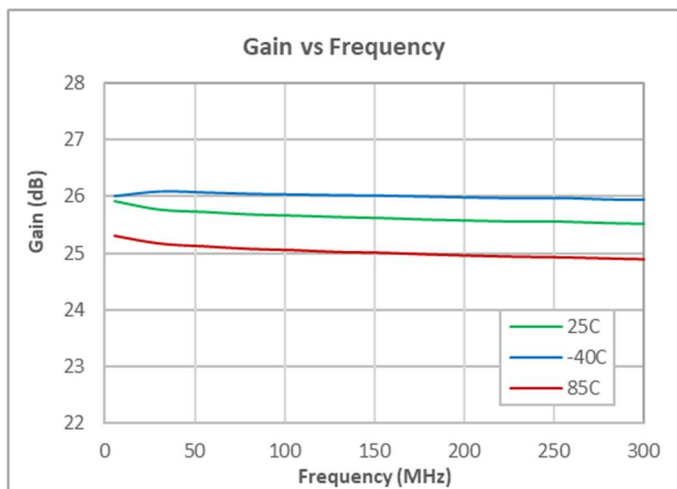
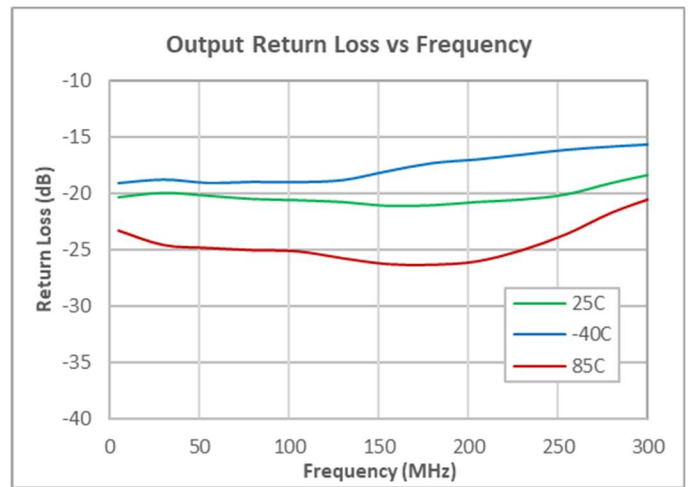
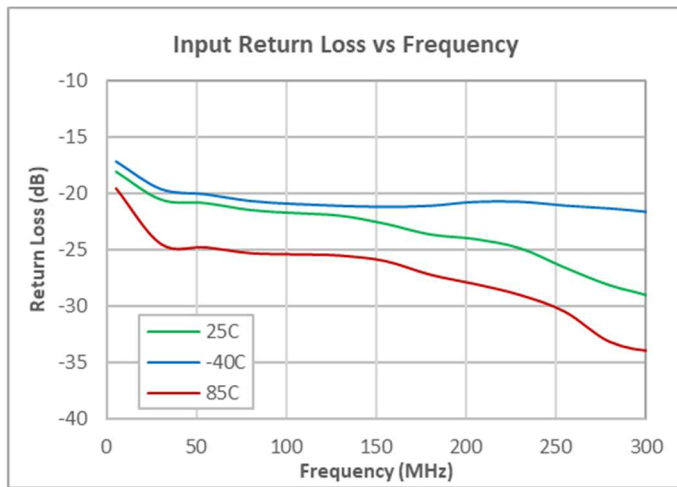

Notes:

- (1) OIP3: +5 dBm/tone, 6 MHz spacing

Performance Data (5 – 300 MHz)

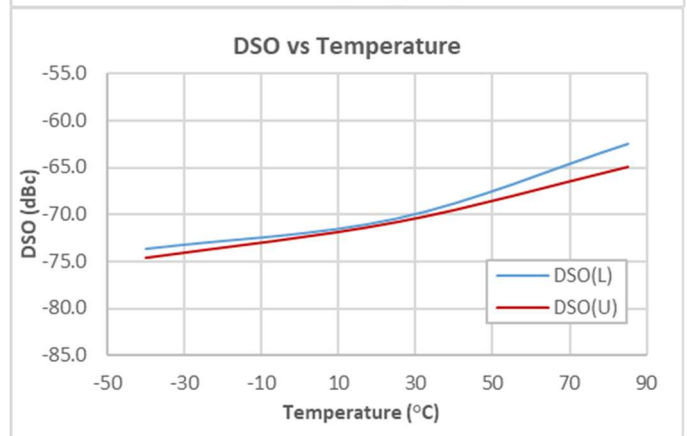
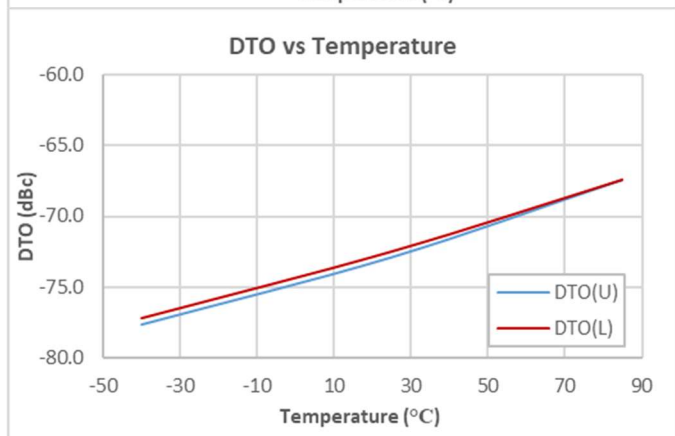
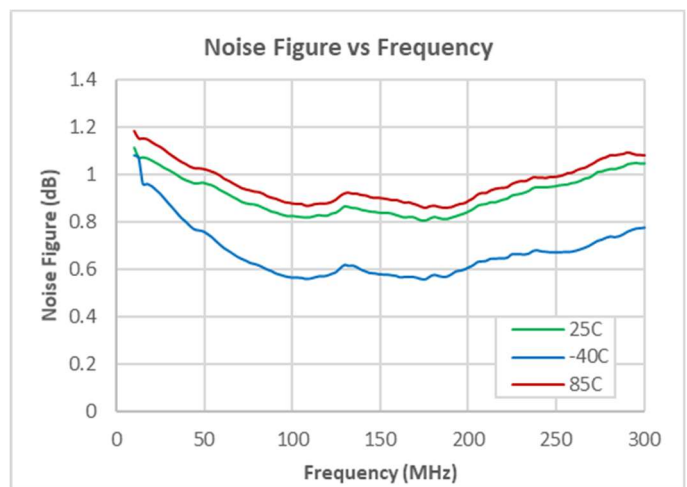
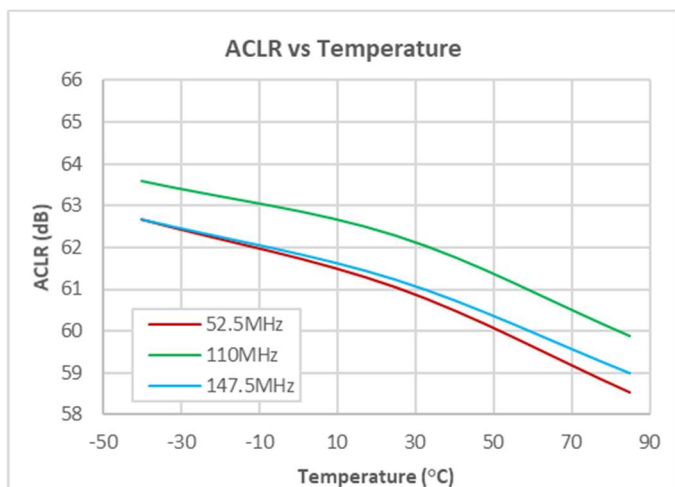
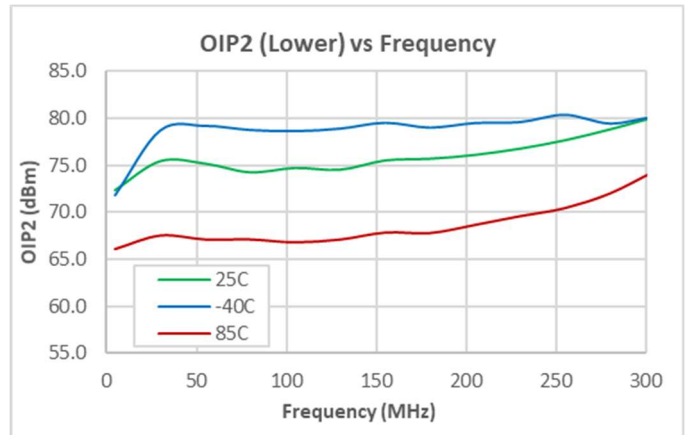
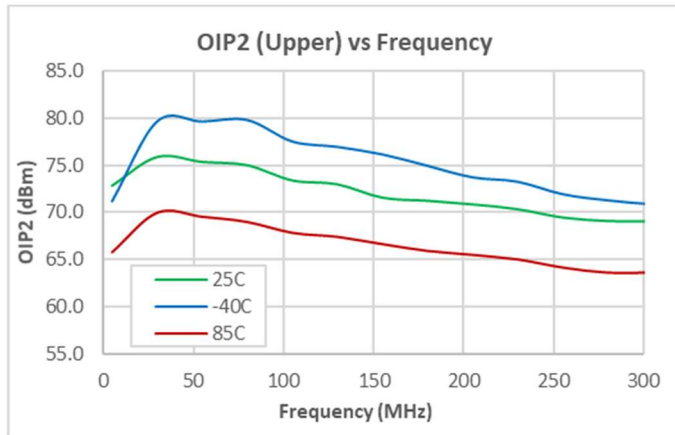

Notes:

- (1) OIP2: 3 dBm/tone, 6 MHz spacing
- (2) ACLR: Pout = 62 dBmV, 5-195 MHz OFDM w/ 9.6 MHz exclusion band.
- (3) DSO/DTO: f1=13 MHz, f2=19 MHz 58.75 dBmV per tone.

Pin Configuration and Description

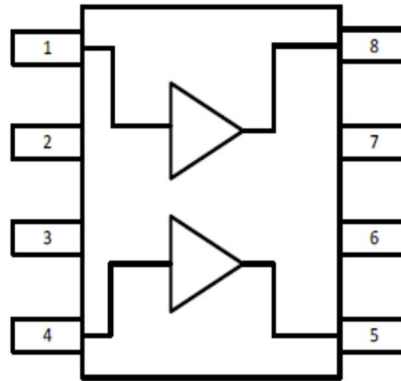

Functional Block Diagram

[Top View](#)

Pin Number	Label	Description
1	RFIN1	RF Input for plus side of amplifier
2	GND	Internally Not Connected
3	GND	Internally Not Connected
4	RFIN2	RF Input for minus side of amplifier
5	RFOUT2	RF Output for minus side of amplifier
6	NC	Internally Not Connected; Can be left open or grounded.
7	GND	Internally Not Connected
8	RFOUT1	RF Output for plus side of amplifier
Backside Paddle	GND	Ground. Use recommended via pattern to minimize inductance and thermal resistance. See PCB Mounting Pattern for suggested footprint.

Package Outline

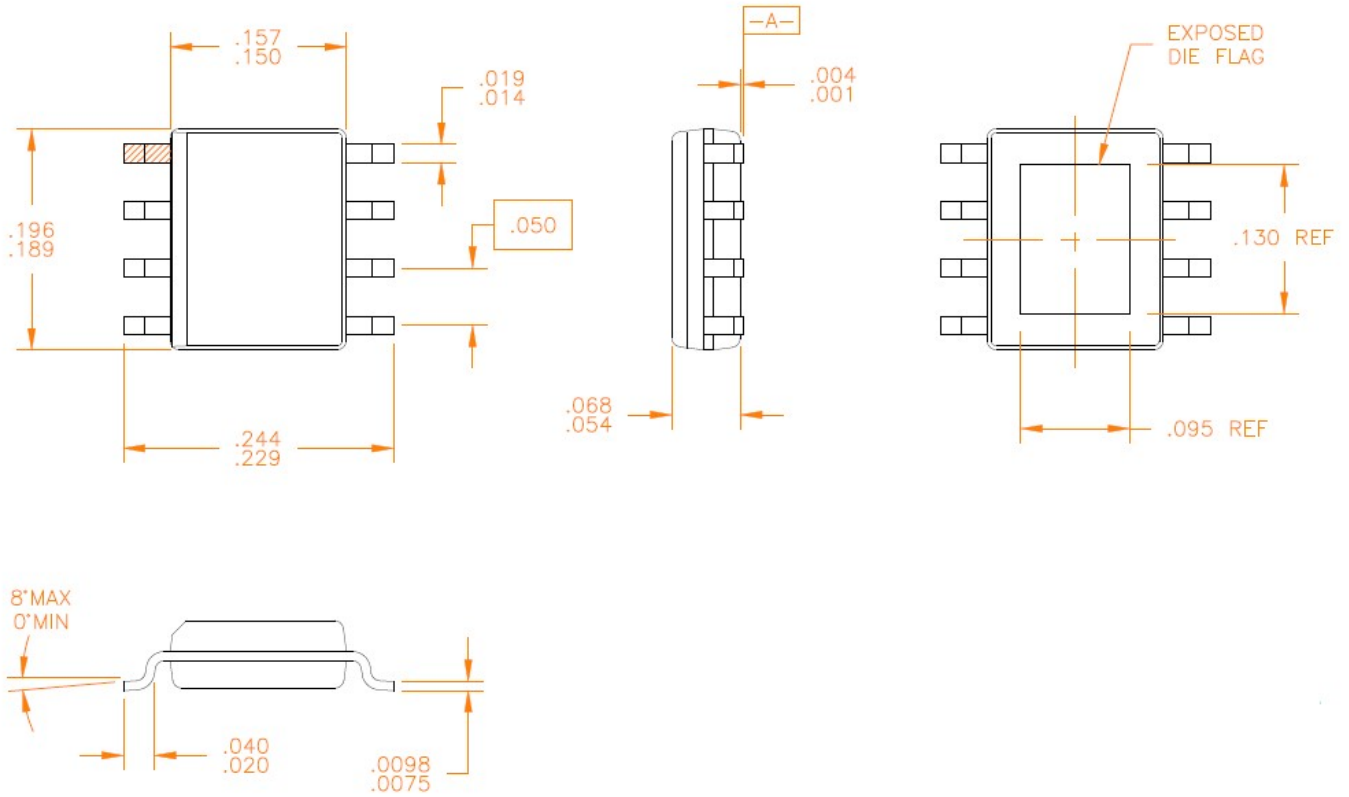

Notes:

1. Dimensions in millimeters

Package Marking

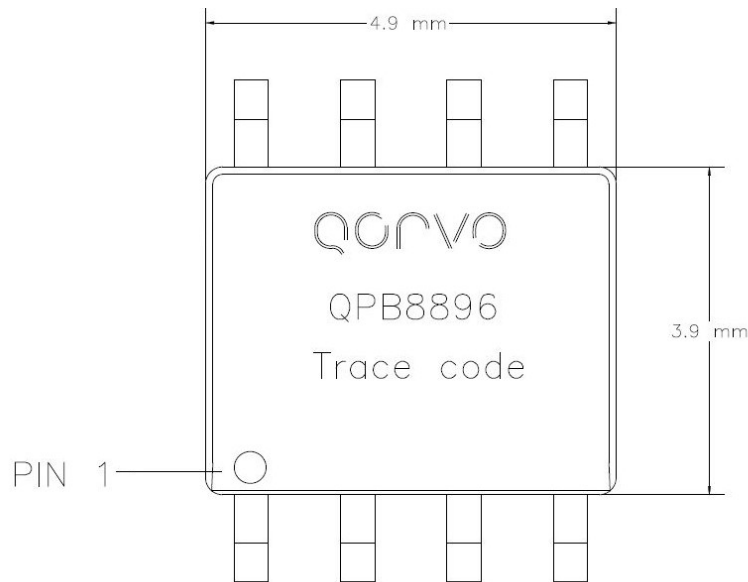

Recommended Mounting Pattern

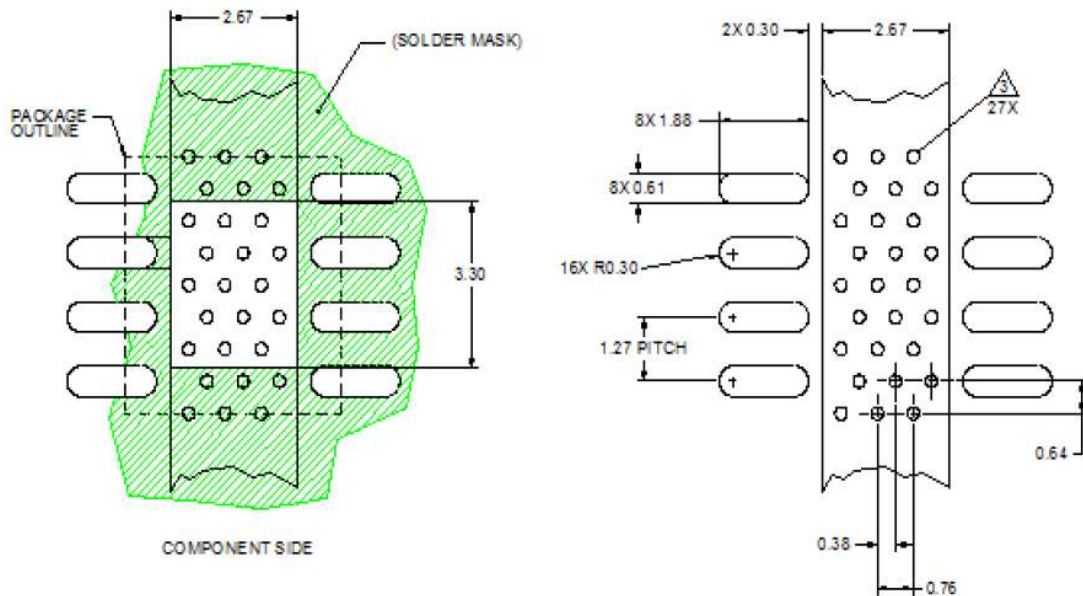

Notes:

1. All dimensions are in millimeters. Angles are in degrees.
2. Use 1 oz. copper minimum for top and bottom layers
3. Vias are required under the backside paddle for proper RF/DC grounding and thermal dissipation. We recommend a 0.35 mm (# 80/0.135") diameter bit for drilling via holes and a final plated through diameter of 0.25 mm (0.010").
4. Ensure good backside paddle solder attach for reliable operation and best electrical performance.

Handling Precautions

Parameter	Rating	Standard
ESD – Human Body Model (HBM)	1A (250V)	ESDA / JEDEC JS-001-2012
ESD – Charged Device Model (CDM)	C3 (1000V)	JEDEC JESD22-C101F
MSL – Moisture Sensitivity Level	Level 2	IPC/JEDEC J-STD-020



Caution!
ESD-Sensitive Device

Solderability

Compatible with both lead-free (260 °C max. reflow temp.) and tin/lead (245 °C max. reflow temp.) soldering processes. Solder profiles available upon request.

Contact plating: Matte Sn

RoHS Compliance

This part is compliant with 2011/65/EU RoHS directive (Restrictions on the Use of Certain Hazardous Substances in Electrical and Electronic Equipment) as amended by Directive 2015/863/EU.

This product also has the following attributes:

- Lead Free
- Halogen Free (Chlorine, Bromine)
- Antimony Free
- TBBP-A (C₁₅H₁₂Br₄O₂) Free
- PFOS Free
- SVHC Free



Contact Information

For the latest specifications, additional product information, worldwide sales and distribution locations:

Tel: 1-844-890-8163

Web: www.qorvo.com

Email: customer.support@qorvo.com

Important Notice

The information contained in this Data Sheet and any associated documents (“Data Sheet Information”) is believed to be reliable; however, Qorvo makes no warranties regarding the Data Sheet Information and assumes no responsibility or liability whatsoever for the use of said information. All Data Sheet Information is subject to change without notice. Customers should obtain and verify the latest relevant Data Sheet Information before placing orders for Qorvo® products. Data Sheet Information or the use thereof does not grant, explicitly, implicitly or otherwise any rights or licenses to any third party with respect to patents or any other intellectual property whether with regard to such Data Sheet Information itself or anything described by such information.

DATA SHEET INFORMATION DOES NOT CONSTITUTE A WARRANTY WITH RESPECT TO THE PRODUCTS DESCRIBED HEREIN, AND QORVO HEREBY DISCLAIMS ANY AND ALL WARRANTIES WITH RESPECT TO SUCH PRODUCTS WHETHER EXPRESS OR IMPLIED BY LAW, COURSE OF DEALING, COURSE OF PERFORMANCE, USAGE OF TRADE OR OTHERWISE, INCLUDING THE IMPLIED WARRANTIES OF MERCHANTABILITY AND FITNESS FOR A PARTICULAR PURPOSE. Without limiting the generality of the foregoing, Qorvo® products are not warranted or authorized for use as critical components in medical, life-saving, or life-sustaining applications, or other applications where a failure would reasonably be expected to cause severe personal injury or death. Applications described in the Data Sheet Information are for illustrative purposes only. Customers are responsible for validating that a particular product described in the Data Sheet Information is suitable for use in a particular application.

© 2021 Qorvo US, Inc. All rights reserved. This document is subject to copyright laws in various jurisdictions worldwide and may not be reproduced or distributed, in whole or in part, without the express written consent of Qorvo US, Inc. | QORVO® is a registered trademark of Qorvo US, Inc.

X-ON Electronics

Largest Supplier of Electrical and Electronic Components

Click to view similar products for [RF Amplifier](#) category:

Click to view products by [Qorvo](#) manufacturer:

Other Similar products are found below :

[A82-1](#) [BGA622H6820XTSA1](#) [BGA 728L7 E6327](#) [BGB719N7ESDE6327XTMA1](#) [HMC397-SX](#) [HMC405](#) [HMC561-SX](#) [HMC8120-SX](#)
[HMC8121-SX](#) [HMC-ALH382-SX](#) [HMC-ALH476-SX](#) [SE2433T-R](#) [SMA3101-TL-E](#) [SMA39](#) [A66-1](#) [A66-3](#) [A67-1](#) [LX5535LQ](#) [LX5540LL](#)
[MAAM02350](#) [HMC3653LP3BETR](#) [HMC549MS8GETR](#) [HMC-ALH435-SX](#) [SMA101](#) [SMA32](#) [SMA411](#) [SMA531](#) [SST12LP19E-QX6E](#)
[WPM0510A](#) [HMC5929LS6TR](#) [HMC5879LS7TR](#) [HMC1126](#) [HMC1087F10](#) [HMC1086](#) [HMC1016](#) [SMA1212](#) [MAX2689EWS+T](#)
[MAAMSS0041TR](#) [MAAM37000-A1G](#) [LTC6430AIUF-15#PBF](#) [CHA5115-QDG](#) [SMA70-2](#) [SMA4011](#) [A231](#) [HMC-AUH232](#) [LX5511LQ](#)
[LX5511LQ-TR](#) [HMC7441-SX](#) [HMC-ALH310](#) [XD1001-BD-000V](#)