

Product Description

The QPF4010 is a high frequency, high performance MMIC front-end module targeted for 5G - n258 at 26 GHz phased array base stations and terminals. It is fabricated on Qorvo’s 90 nm pHEMT (QPHT09) production process. The device combines a low noise high linearity LNA, a low insertion-loss high-isolation TR switch, and a high-efficiency multi-stage PA.

The QPF4010 covers a frequency range from 24.25 GHz to 27.5 GHz. The receive path (LNA + TR SW) is designed to provide 13.5 dB of gain and a typical noise figure of 4.0 dB. The transmit path (PA+SW) provides 17 dB of small signal gain and a saturated output power of 22.5 dBm. It can operate at an average power of 14 dBm with 4% typical EVM at 64 QAM, 100MHz modulated signal.

The QPF4010 is offered in a small 4x4 mm overmold QFN surface mount package, matched to 50 Ω and has integrated DC blocking capacitors on all RF ports allowing for simple system integration. The frequency coverage and operational flexibility allows it to support satellite communication, point to point data links and 5G systems.

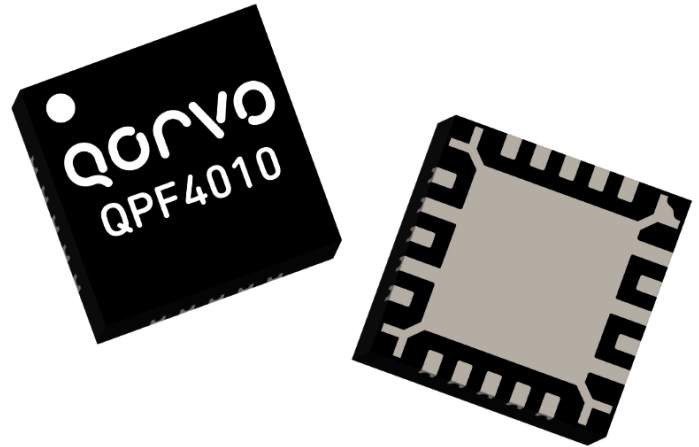

Product Features

- Frequency Range: 24.25 – 27.5 GHz
- RX Noise Figure: 4.0 dB
- RX Small Signal Gain: 13.5 dB
- RX Output TOI : 14 dBm @ - 10 dBm Pin / tone
- TX Small Signal Gain: 17 dB
- TX Saturated Power: 22.5 dBm
- TX ACPR: 32dBc @ 14 dBm average Pout ²
- TX Linearity: 4 % EVM @ 14 dBm average Pout ²
- TX PAE: 5 % @ 14 dBm average Pout
- Package Dimensions: 4.0 x 4.0 x 0.85 mm

1. Performance is typical at room temperature.
2. OFDM, 100 MHz modulation bandwidth, 64QAM.

Applications

- 5G Wireless base stations and terminals
- Point to Point communications
- Repeaters, small cells and CPE

Functional Block Diagram

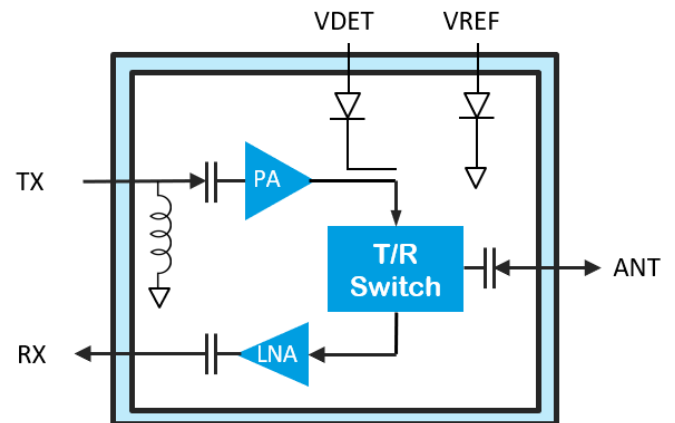

Ordering Information

Part No.	Description
QPF4010SR	Tape and Reel 7", Qty 100
QPF4010EVB1	QPF4010 Evaluation Board, Qty 1

Normal Operating Conditions ¹

Parameter	Value	Units
Drain Voltage (TXVD)	2.5	V
Drain Current (TXIDQ)	215	mA
Drain Voltage (RXVD)	3.5	V
Drain Current (RXIDQ)	10	mA
Gate Voltage (TXVG1/TXVG2) ²	-0.5	V
RX Current Adjust (RXADJ)	Connect to an external resistor to adjust RX drain current	-
Switch Control (SWCTRL) ³	3.5 (Switch to RX Channel) / 0 (Switch to TX Channel)	V
Switch Reference (SWREF)	3.5	V
Operating Temperature Range	-40 to 85	°C

- 1 Electrical specifications are measured at specified test conditions. Specifications are not guaranteed over all recommended operating conditions.
- 2 Gate voltage shown are typical, can be adjusted to set required drain current. TXVG1 and TXVG2 can be connected.
- 3 The SWCTRL logic high voltage (Switch to RX operation) should be the same as SWREF.

Absolute Maximum Ratings

Parameter	Min Value	Max Value	Units
Drain Voltage (TXVD, RXVD)	-	4.5	V
Drain Current (RXID)	-	30	mA
Drain Current (TXID)	-	345	mA
Gate Voltage (TXVG1, TXVG2)	-1.5	0	V
Gate Current (TXIG1, TXIG2)	-	2	mA
Switch Reference Voltage (SWREF)	0	4.0	V
Switch Control Voltage (SWCTRL)	0	SWREF	V
Switch Control and Switch Ref Current	-	1.5	mA
RF Input Power (All RF ports, 85 °C)	-	23	dBm
Channel Temperature, T _{CH}	-	150	°C
Mounting Temperature (30 seconds)	-	260	°C
Storage Temperature	-55	150	°C

Operation of this device outside the parameter ranges given above may cause permanent damage. These are stress ratings only, and functional operation of the device at these conditions is not implied. Extended application of Absolute Maximum Rating conditions to the device may reduce device reliability.

Electrical Specifications RX

Test conditions, unless otherwise noted: VD = 3.5 V, IDQ = 10 mA, SWCTRL = 3.5 V, SWREF = 3.5 V.
Data de-embedded to device reference planes, 25 °C

Parameter	Min	Typical	Max	Units
Frequency	24.25		27.5	GHz
Small Signal Gain		13.5		dB
Noise Figure		4.0		dB
Saturated Output Power		4.5		dBm
Input Return Loss		12		dB
Output Return Loss		15		dB
Output TOI, @ - 10 dBm Pin / tone, 111 MHz tone spacing		14		dBm
Switch Rise Time ¹		14		nS
Switch Fall Time ²		4		nS
Gain Temperature Coefficient		-0.013		dB/°C

1 From 50% trigger signal to 90 % of RF on.

2 From 50% trigger signal to 10 % of RF off

Electrical Specifications TX

Test conditions unless otherwise noted: VD = 2.5 V, TXIDQ = 215 mA, SWCTRL = 0 V, SWREF = 3.5 V.
Data de-embedded to device reference planes, 25 °C

Parameter	Min	Typical	Max	Units
Frequency	24.25		27.5	GHz
Small Signal Gain		17		dB
Input Return Loss		13		dB
Output Return Loss		14		dB
Saturated Output Power		22.5		dBm
P1dB		21		dBm
PAE at average output power (14dBm)		5		%
Output TOI, @ 10 dBm Pout / tone, 111 MHz tone spacing		31		dBm
ACPR (14 dBm average power, OFDM, 100MHz, 64QAM)		-32		dBc
EVM (14 dBm average power, OFDM, 100MHz, 64QAM)		4		%
Power Detector Output (For output power @ 23 dBm) ³		0.48		V
Switch Rise Time ¹		36		nS
Switch Fall Time ²		14		nS
Gain Temperature Coefficient		-0.021		dB/°C

1 From 50% trigger signal to 90 % of RF on.

2 From 50% trigger signal to 10 % of RF off.

3 Value is VREF - VDET

Performance Plots, Small Signal, Receive Path

Test Conditions unless otherwise stated: RXVD = 3.5 V, RXIDQ = 10 mA, 25 °C

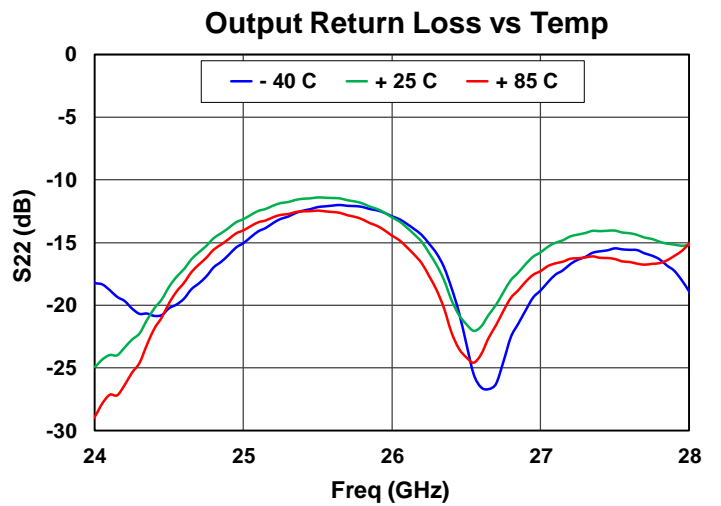
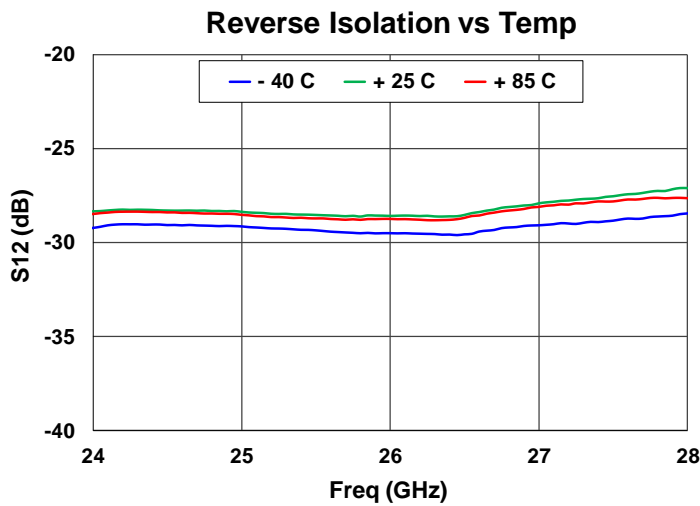
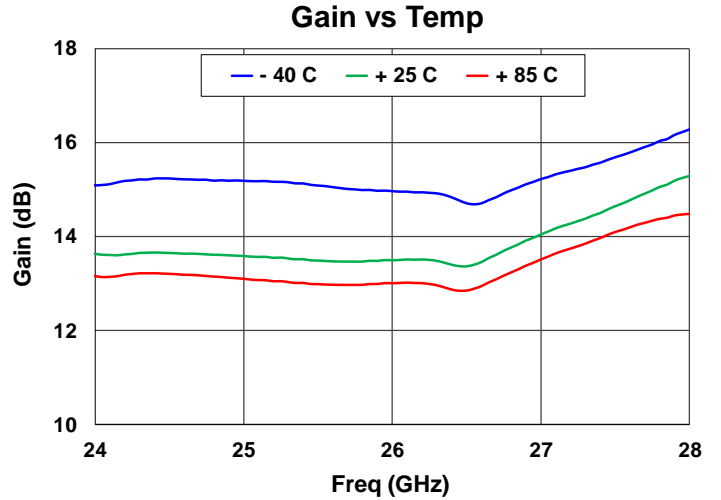
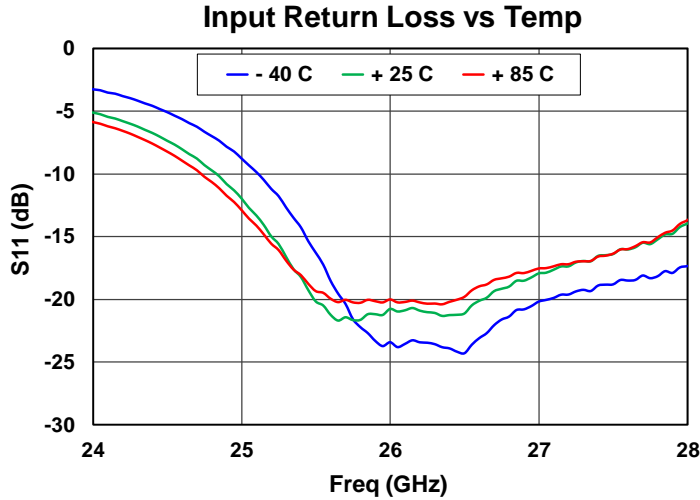

Performance Plots, Small Signal, Receive Path

Test Conditions unless otherwise stated: RXVD = 3.5 V, RXIDQ = 10 mA, 25 °C

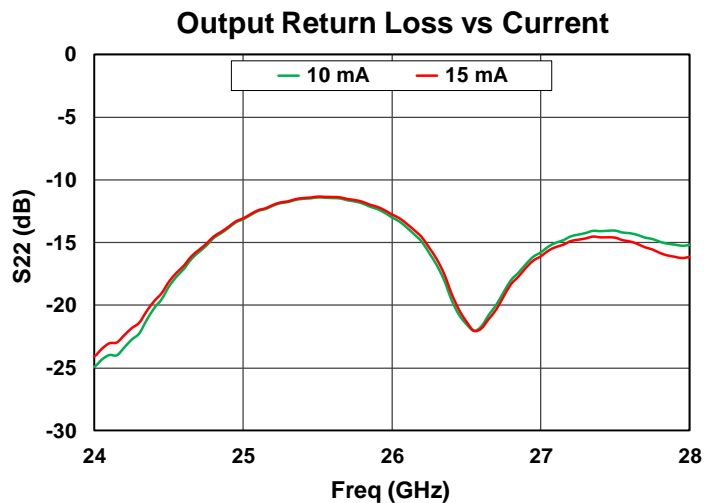
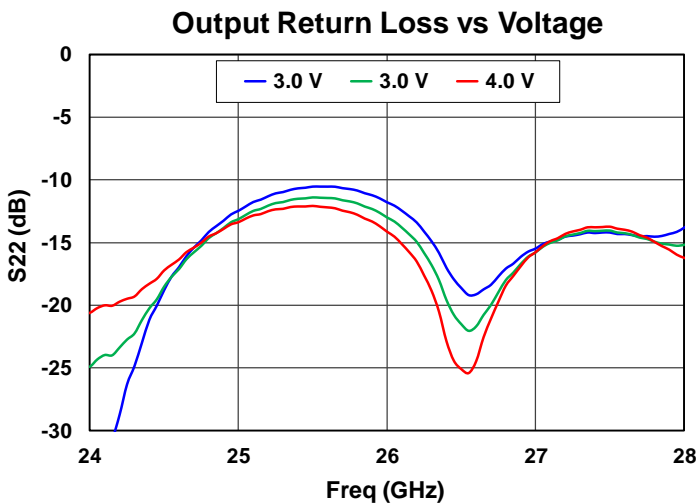
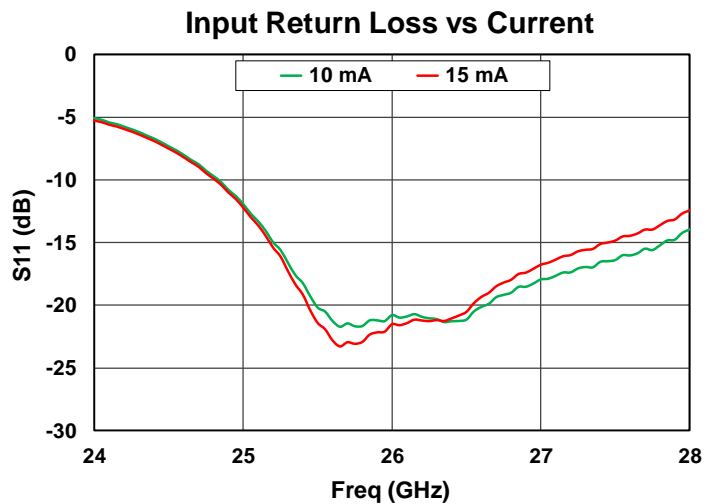
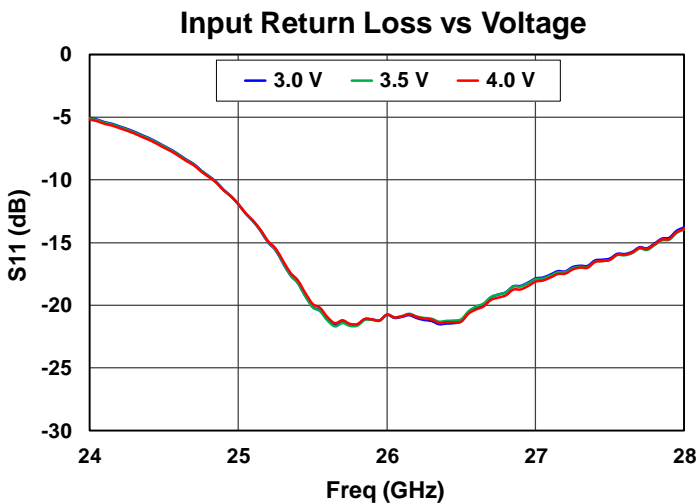
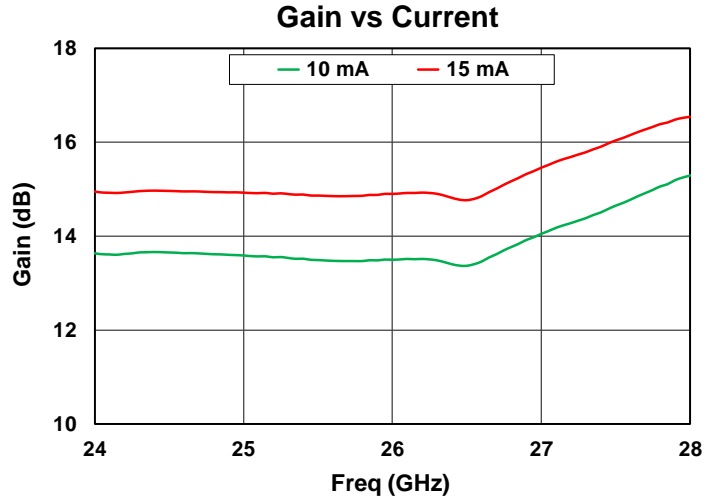
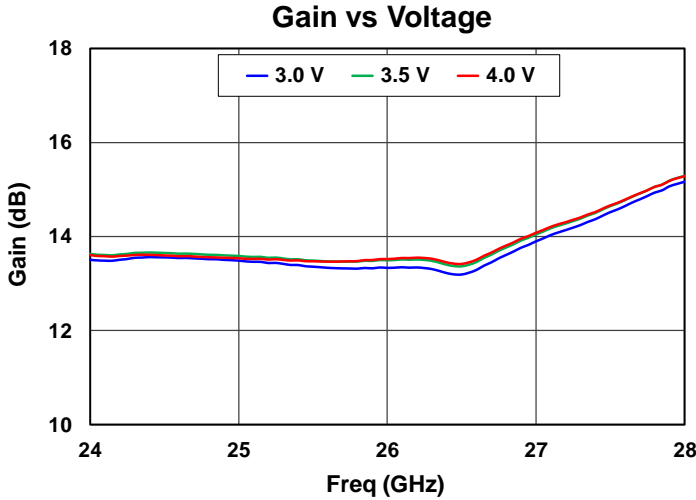

Performance Plots, Noise Figure, Receive Path

Test Conditions unless otherwise stated: RXVD = 3.5 V, RXIDQ = 10 mA, 25 °C

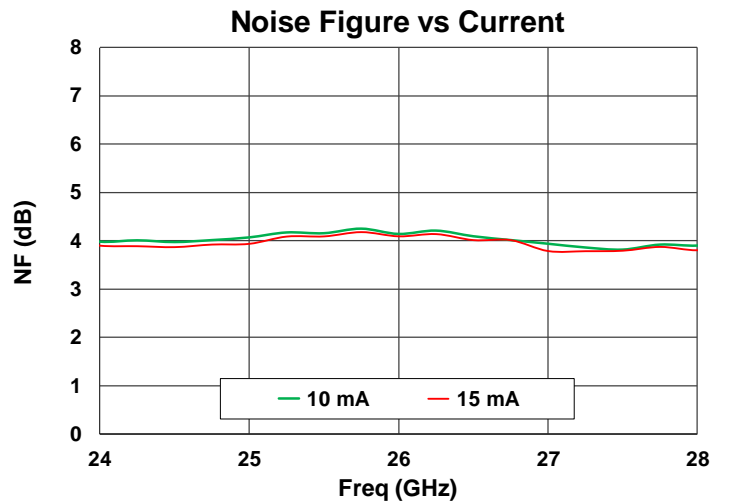
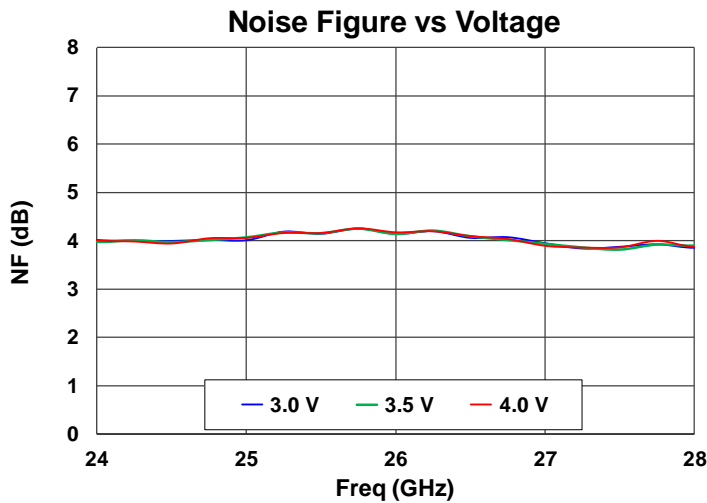
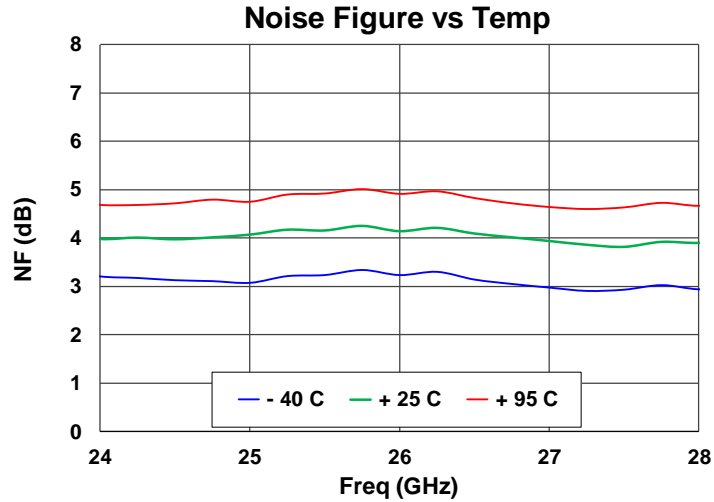

Performance Plots, Large Signal, Receive Path

Test Conditions unless otherwise stated: RXVD = 3.5 V, RXIDQ = 10 mA, CW, 25 °C

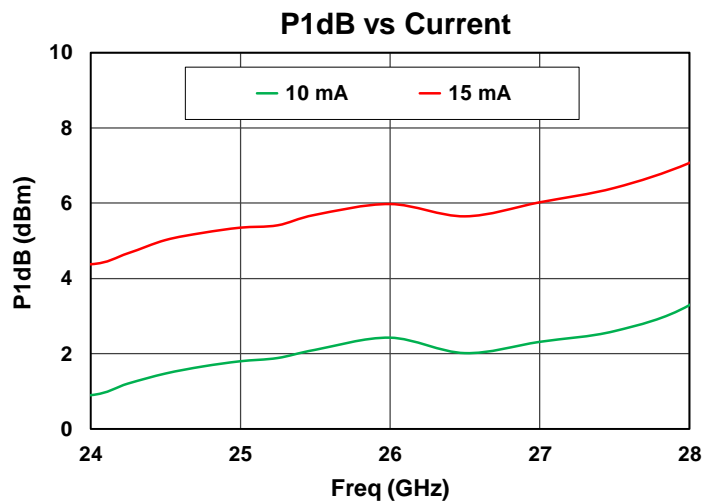
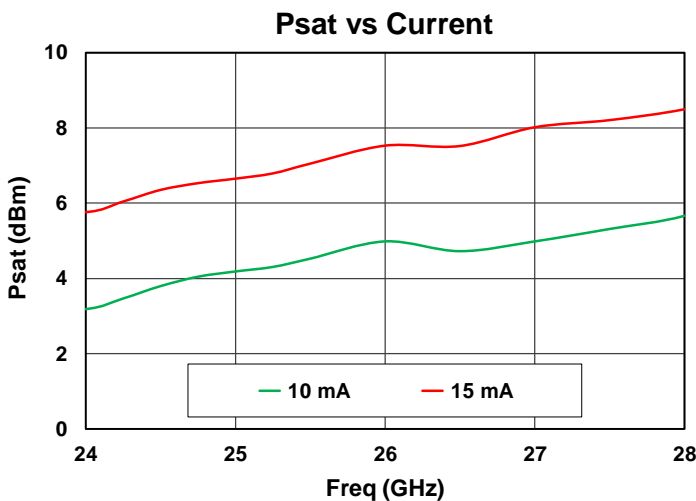
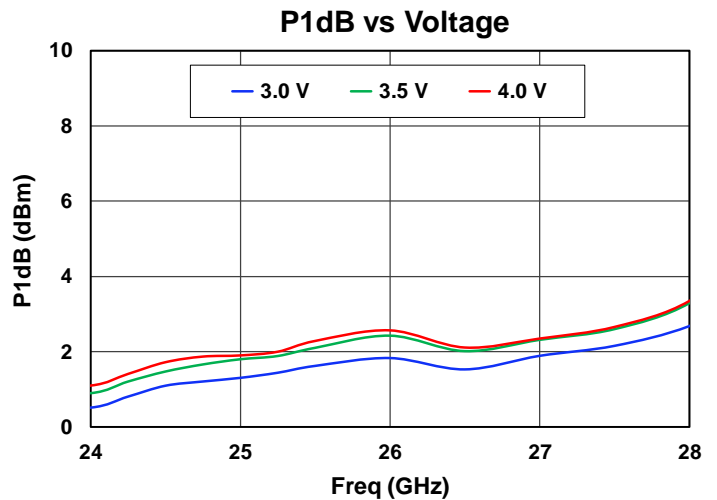
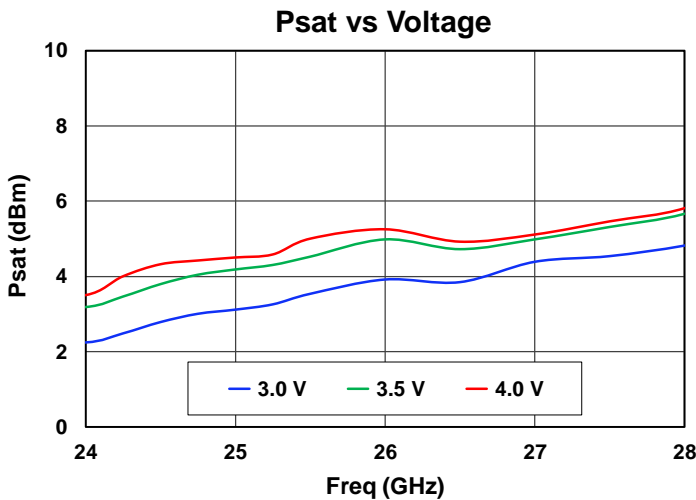
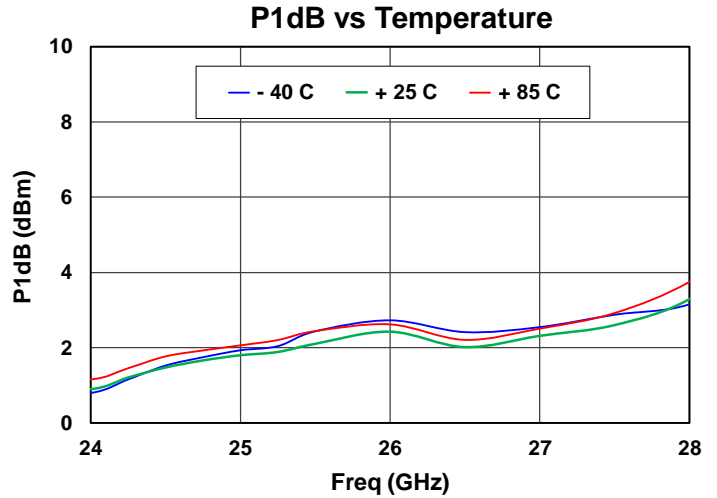
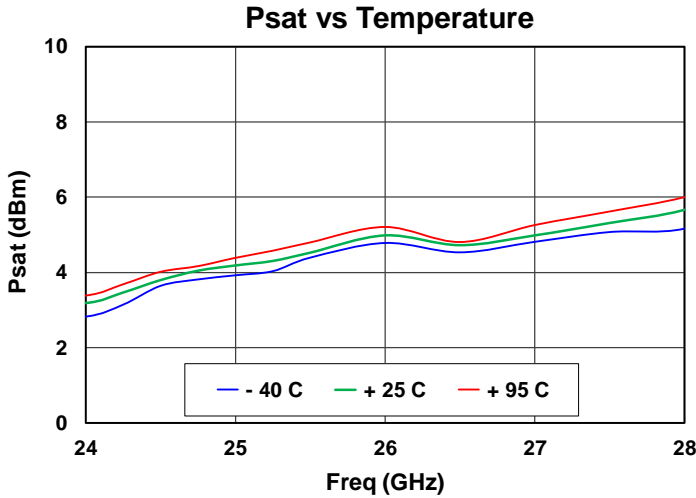

Performance Plots, Large Signal, Receive Path

Test Conditions unless otherwise stated: RXVD = 3.5 V, RXIDQ = 10 mA, CW, 25 °C

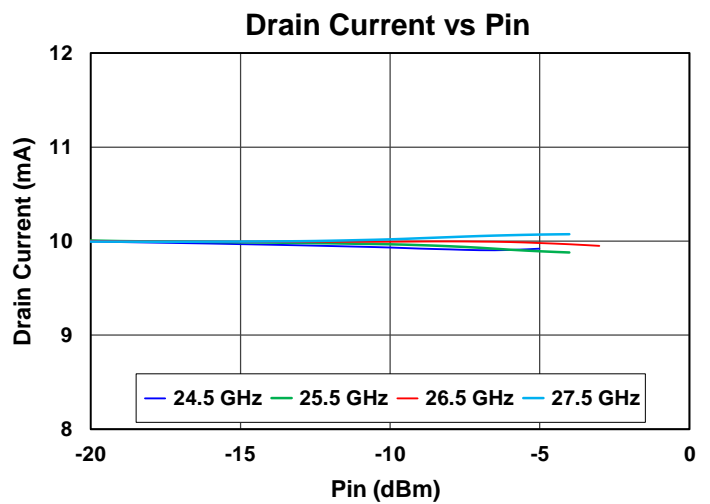
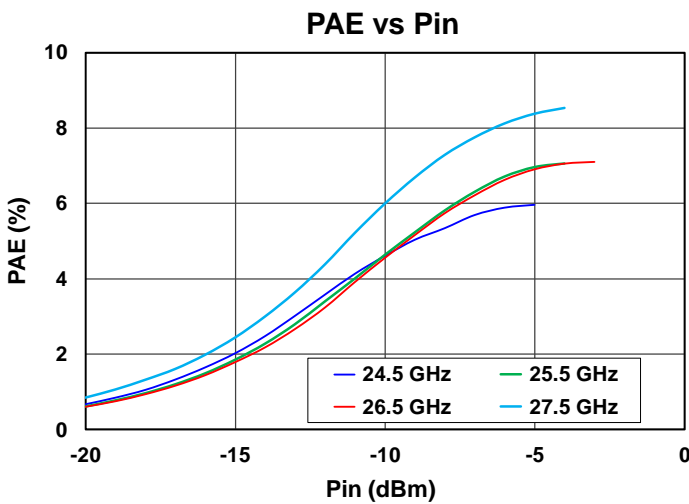
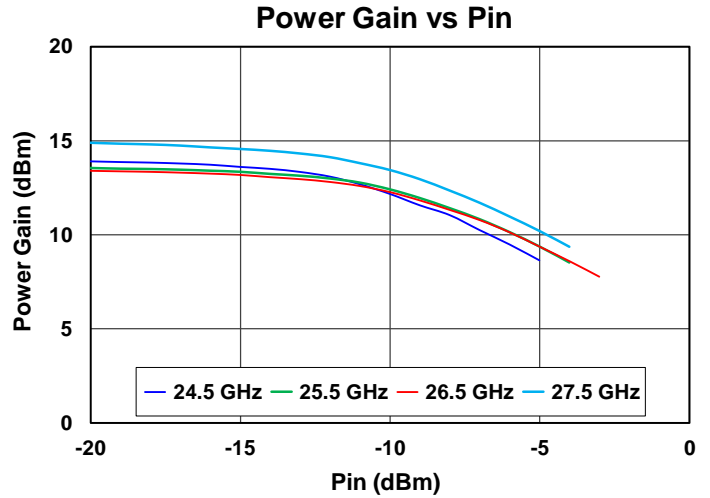
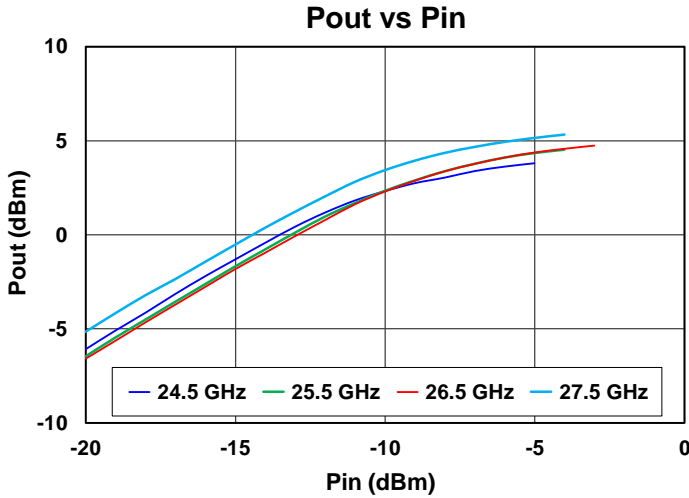

Performance Plots, Linearity, Receive Path

Test Conditions unless otherwise stated: RXVD = 3.5 V, RXIDQ = 10 mA, Tone spacing: 111 MHz, 25 °C

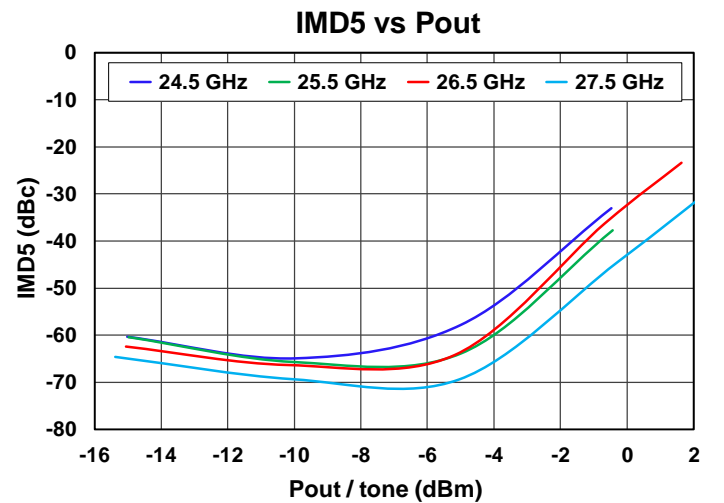
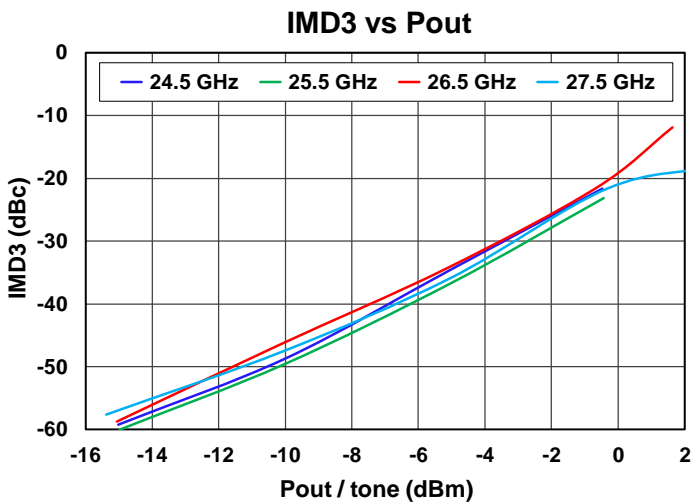
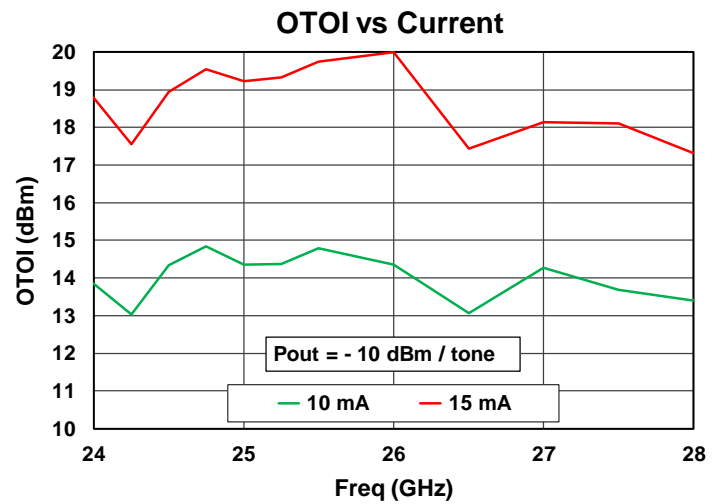
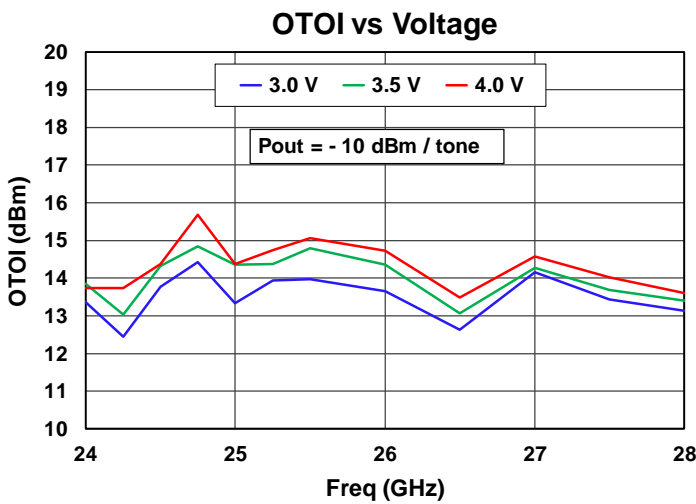
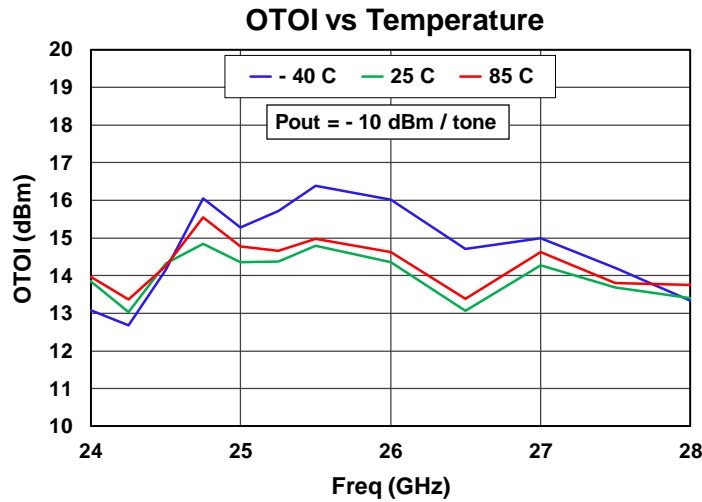

Performance Plots, Small Signal, Transmit Path

Test Conditions unless otherwise stated: TXVD = 2.5 V, TXIDQ = 215 mA, 25 °C

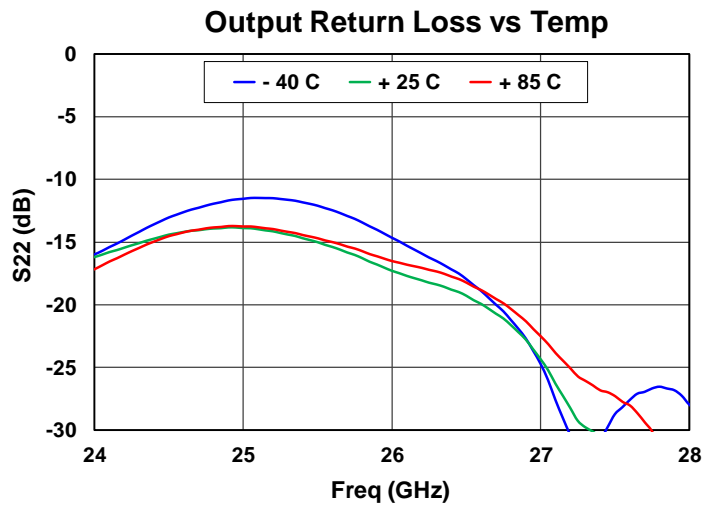
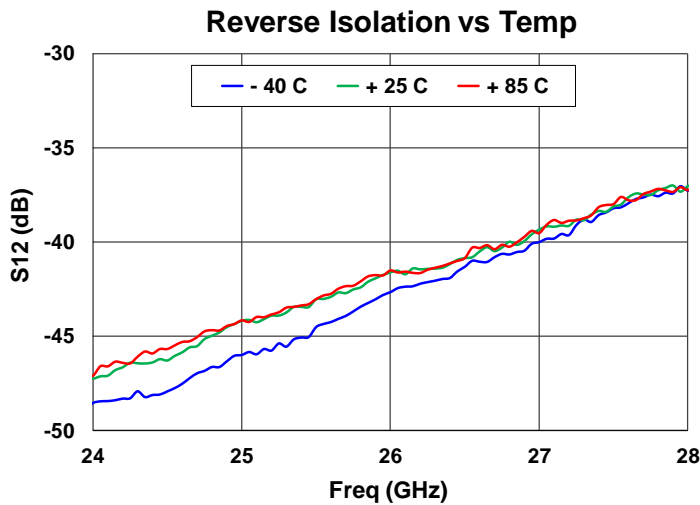
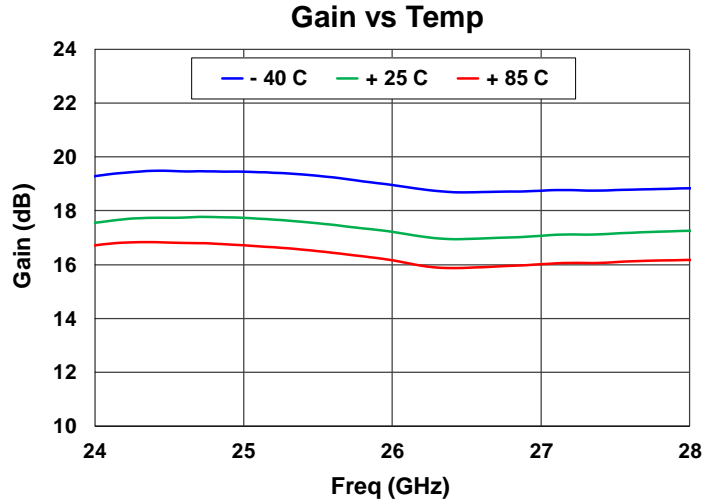
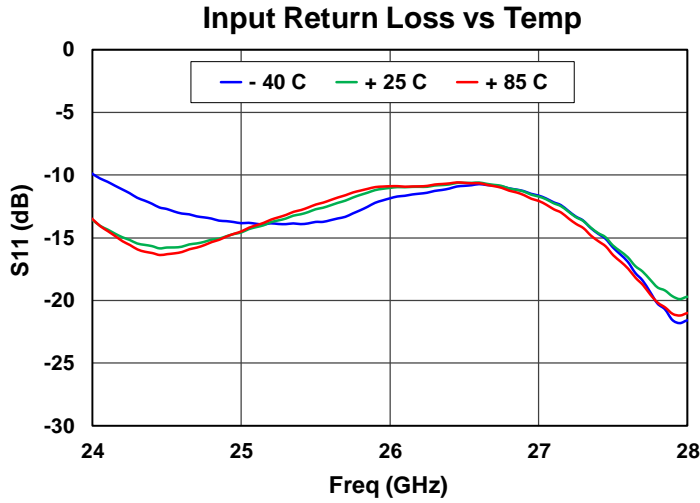

Performance Plots, Small Signal, Transmit Path

Test Conditions unless otherwise stated: TXVD = 2.5 V, TXIDQ = 215 mA, 25 °C

Gain vs Voltage

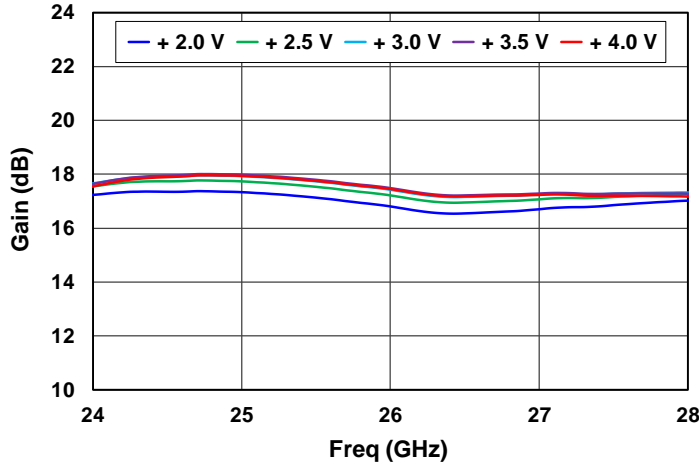

Gain vs Current

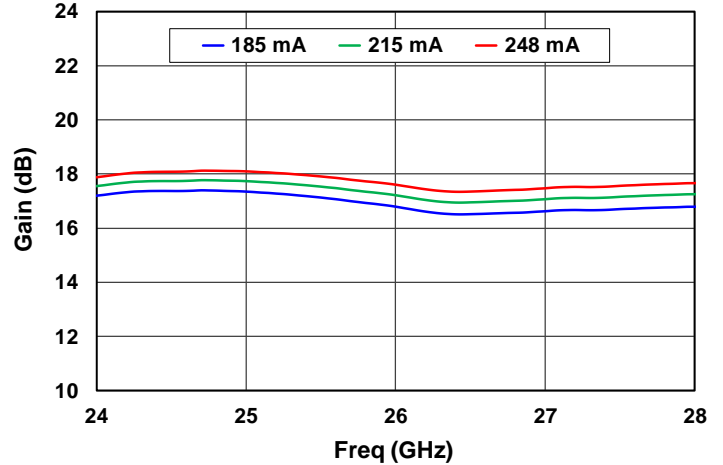

Input Return Loss vs Voltage

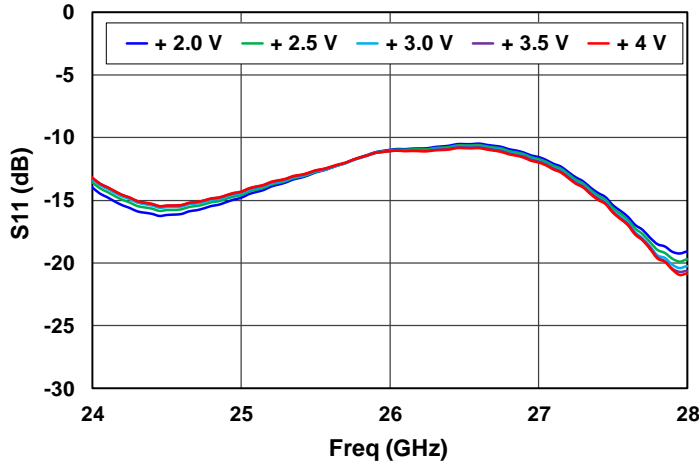

Input Return Loss vs Current

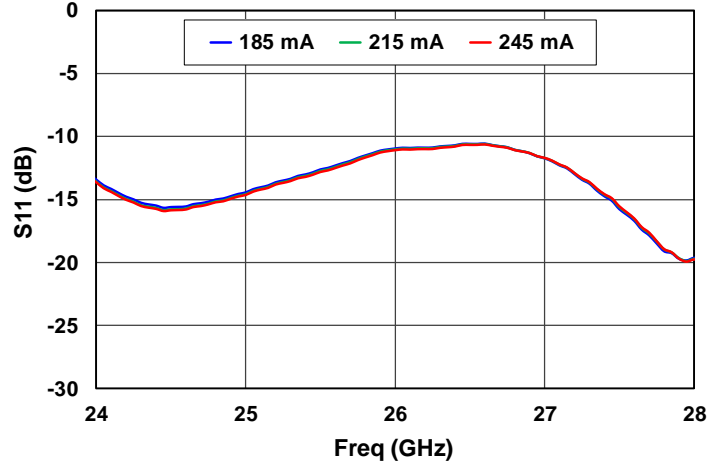

Output Return Loss vs Voltage

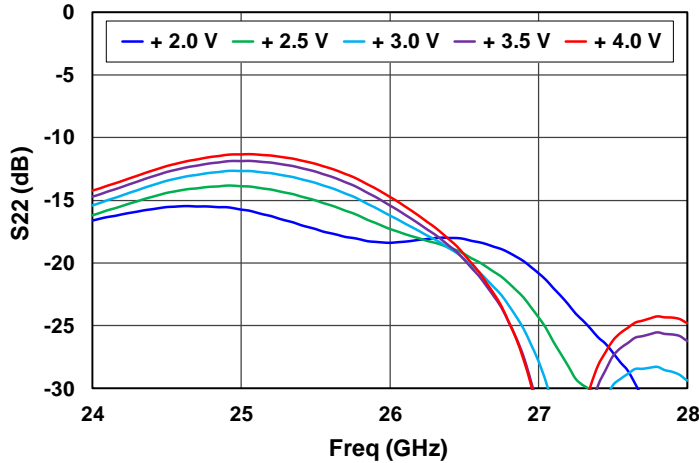

Output Return Loss vs Current

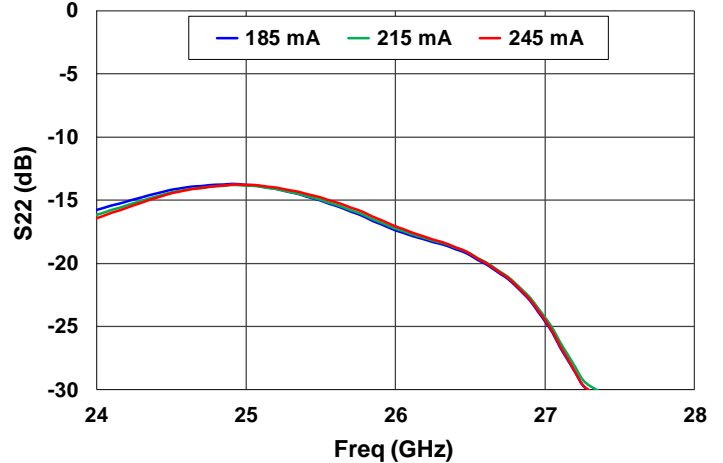

Performance Plots, Large Signal, Transmit Path

Test Conditions unless otherwise stated: TXVD = 2.5 V, TXIDQ = 215 mA, CW, 25 °C

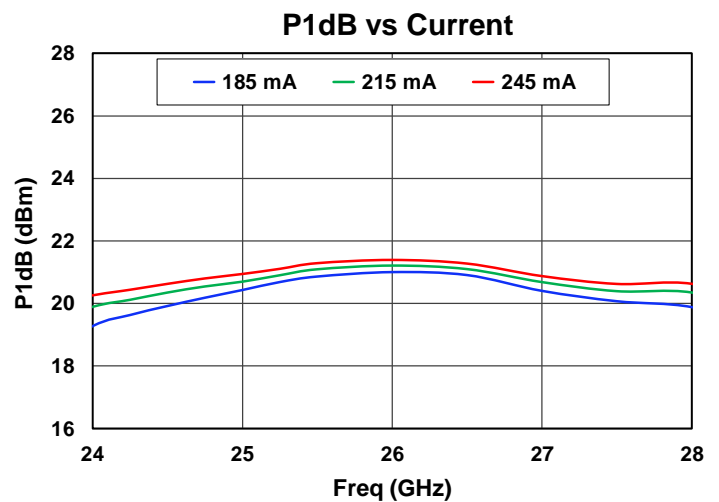
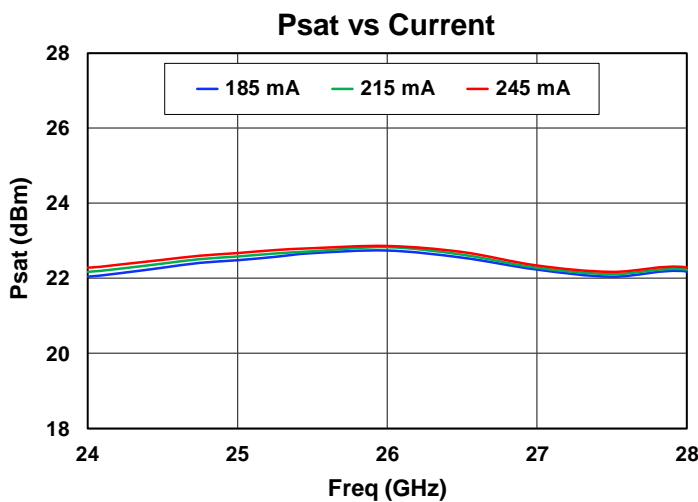
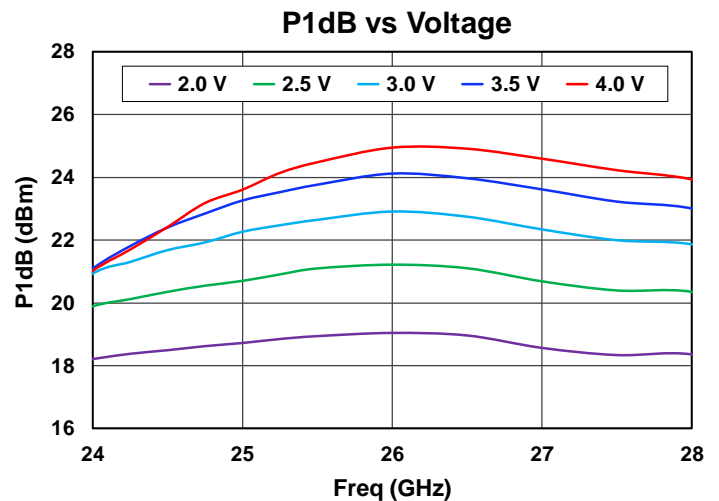
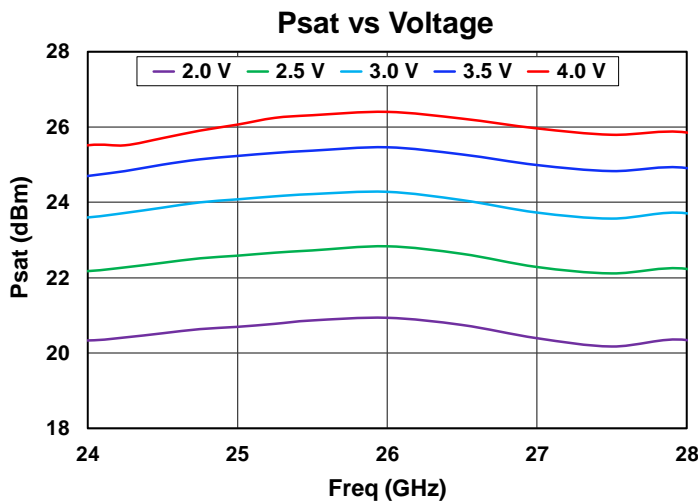
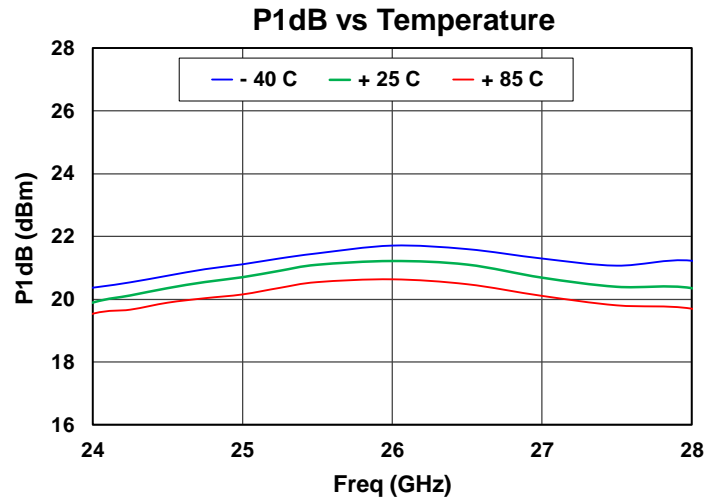
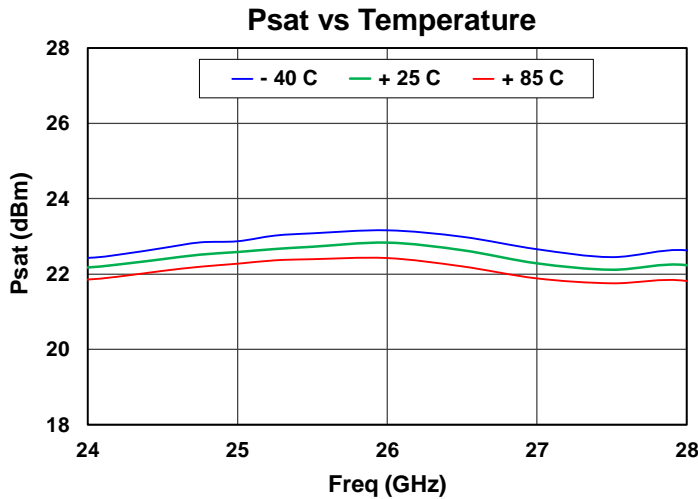

Performance Plots, Large Signal, Transmit Path

Test Conditions unless otherwise stated: TXVD = 2.5 V, TXIDQ = 215 mA, CW, 25 °C

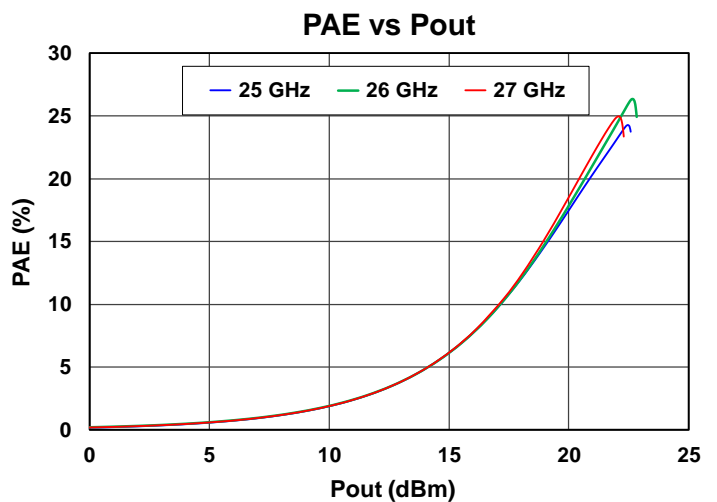
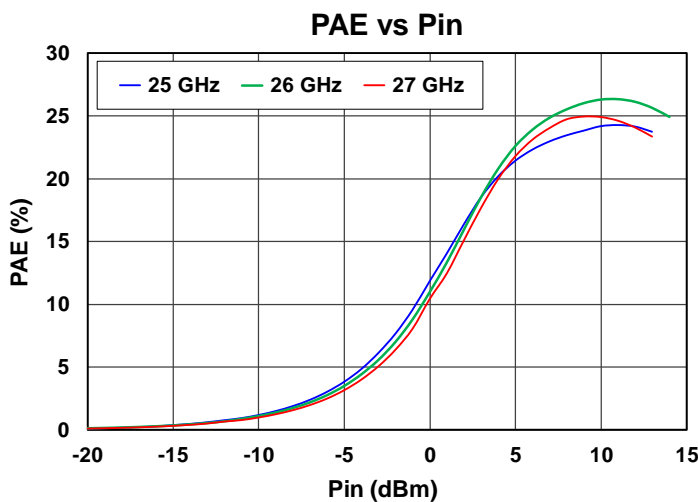
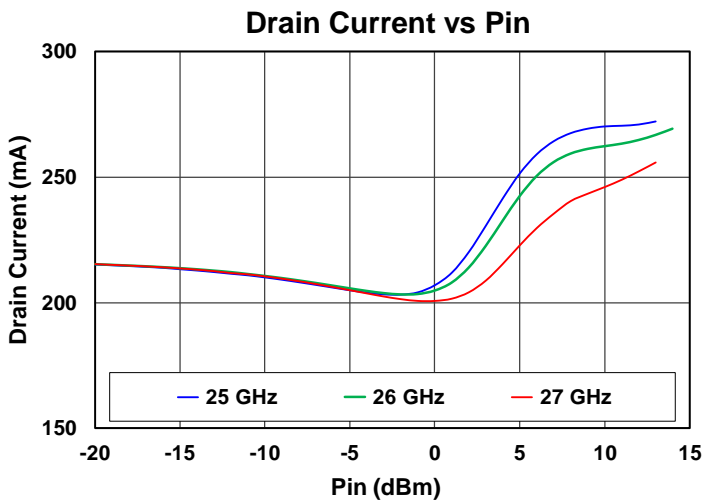
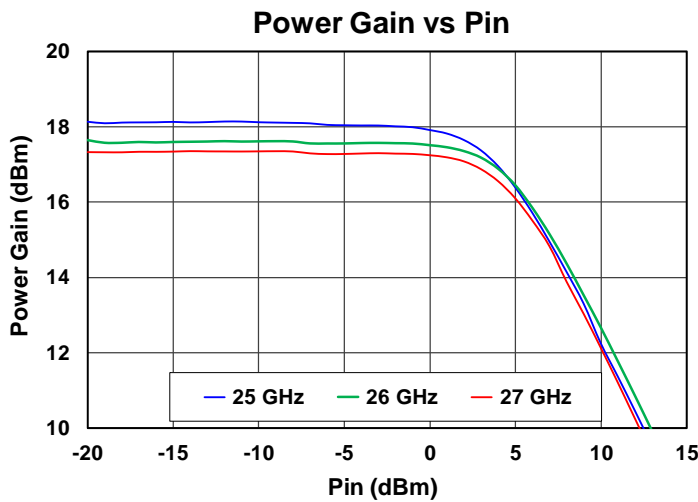
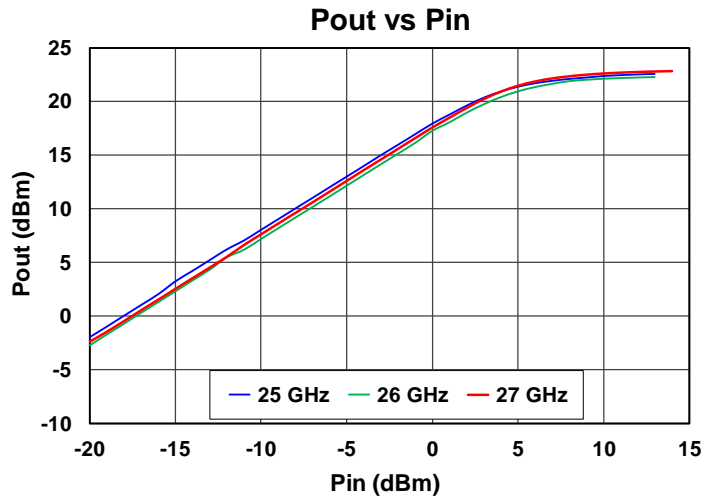
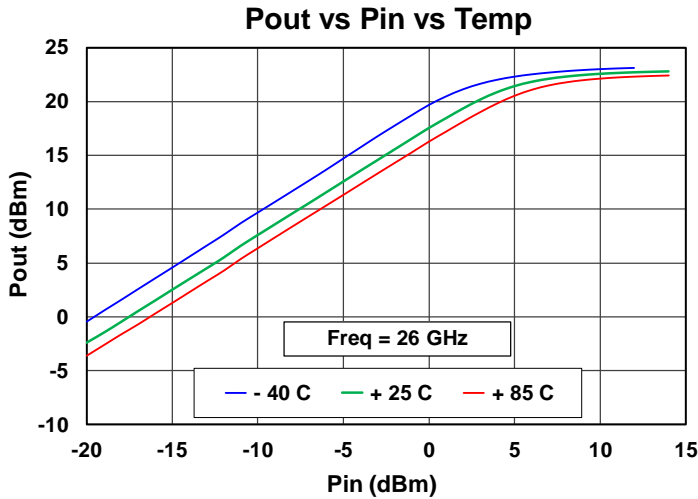

Performance Plots, Power Detection and Isolation

Test Conditions unless otherwise stated: TXVD = 2.5 V, TXIDQ = 215 mA, RXVD = 0 V, RXIDQ = 0 mA, CW, 25 °C
 Plot value of Power Detector is VREF – VDET. Isolation is for small signal condition.

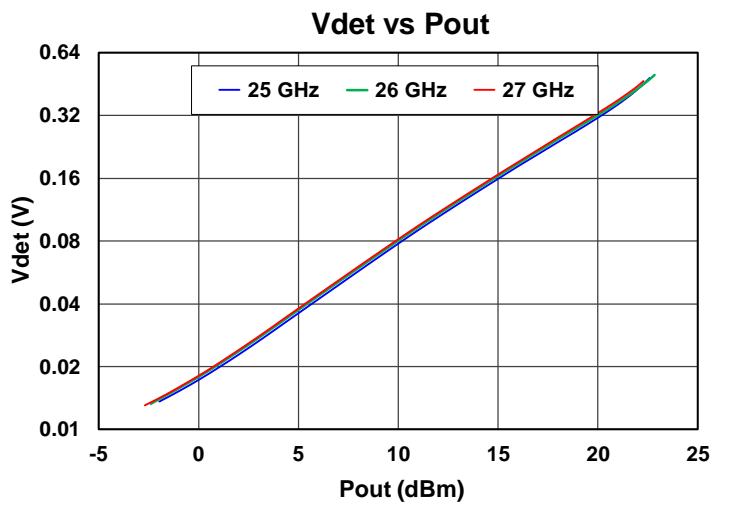
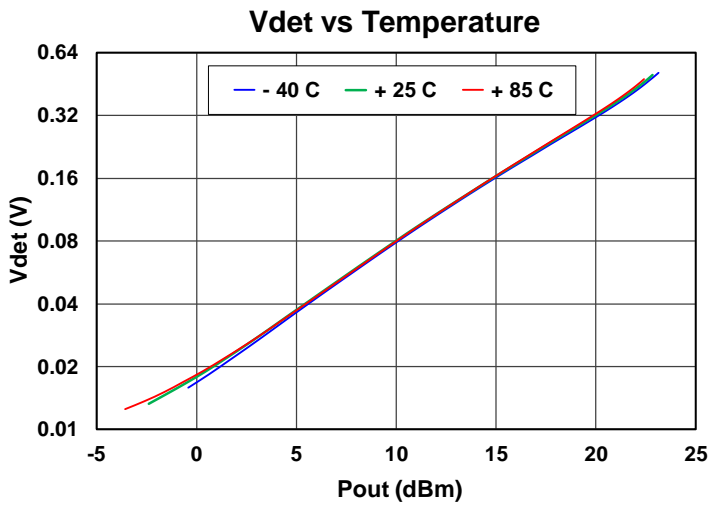
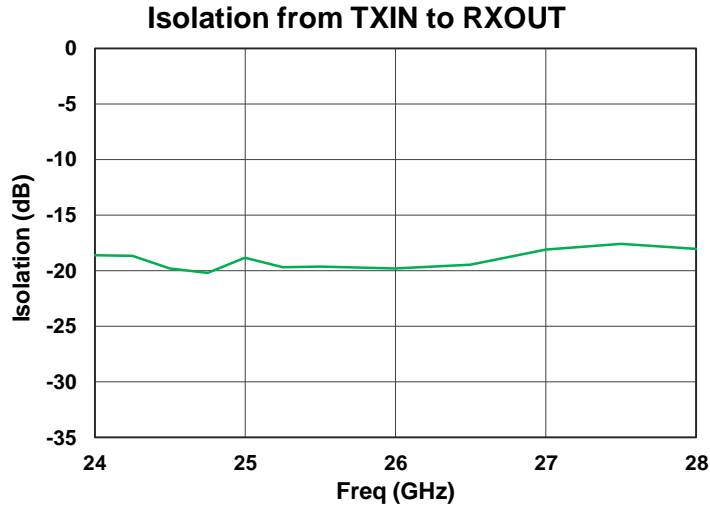

Performance Plots, Linearity, Transmit Path

Test Conditions unless otherwise stated: TXVD = 2.5 V, TXIDQ = 215 mA, Tone Spacing = 111 MHz, 25 °C

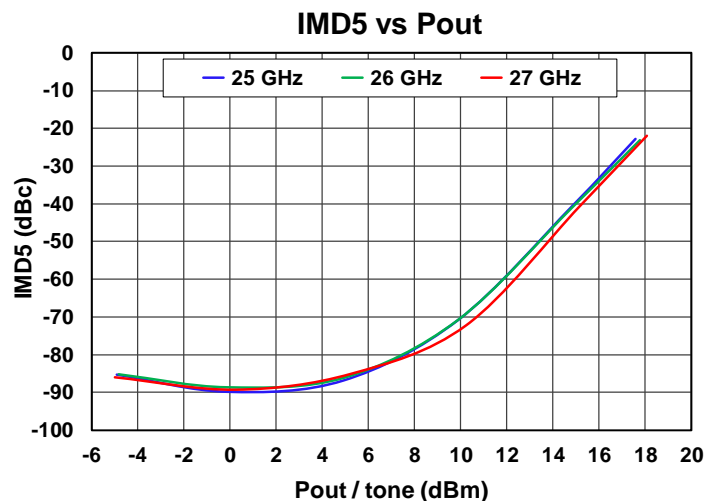
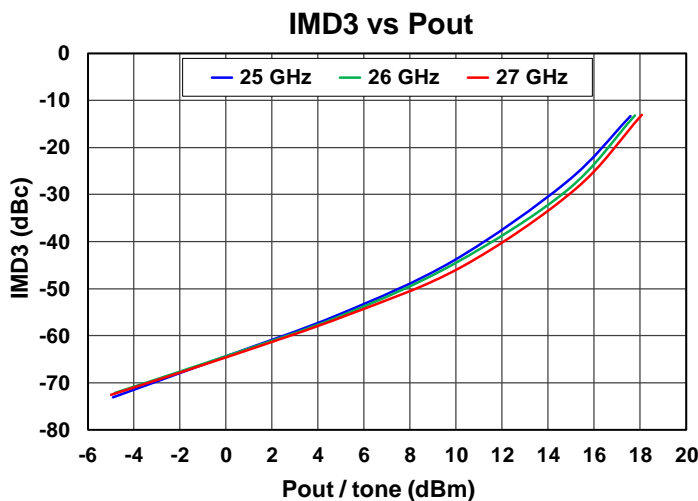
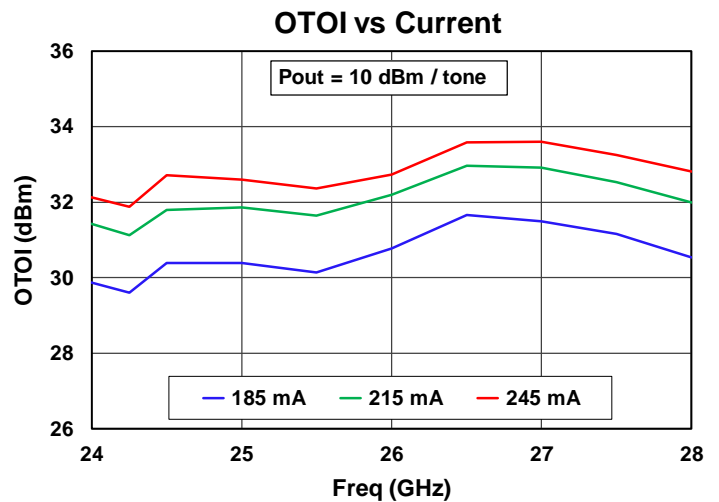
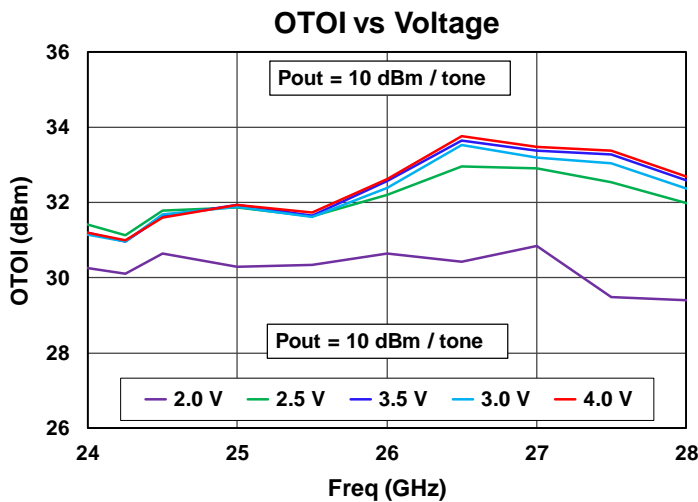
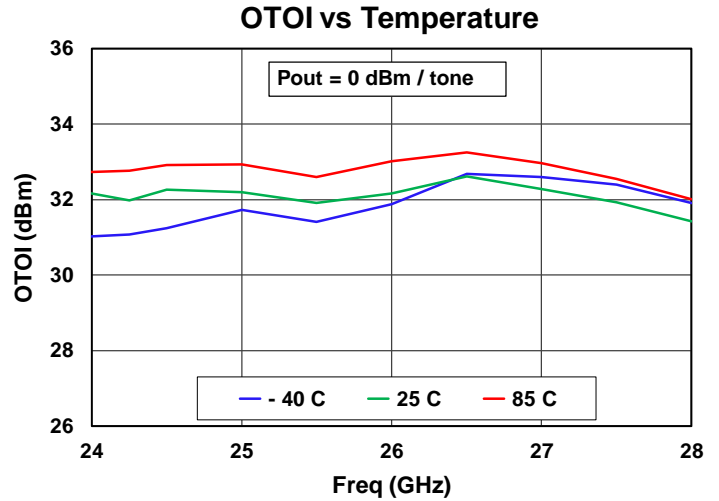
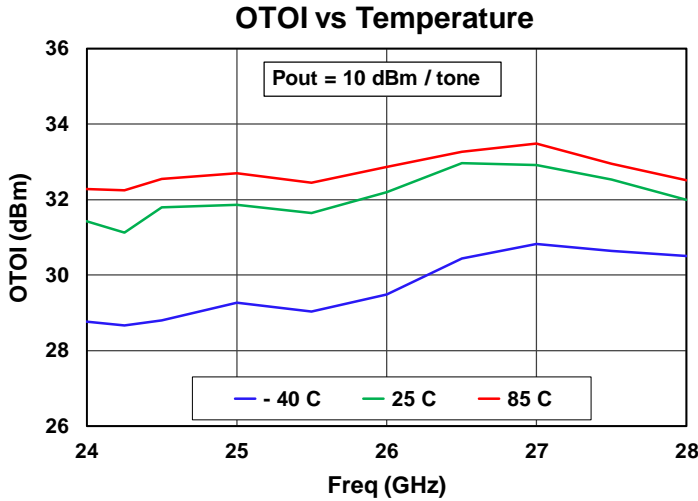

Performance Plots, Modulated Signal, Transmit Path

Test Conditions unless otherwise stated: TXVD = 2.5 V, TXIDQ12 = 215 mA, Source: 400 MHz OFDM, 64 QAM, 25 °C

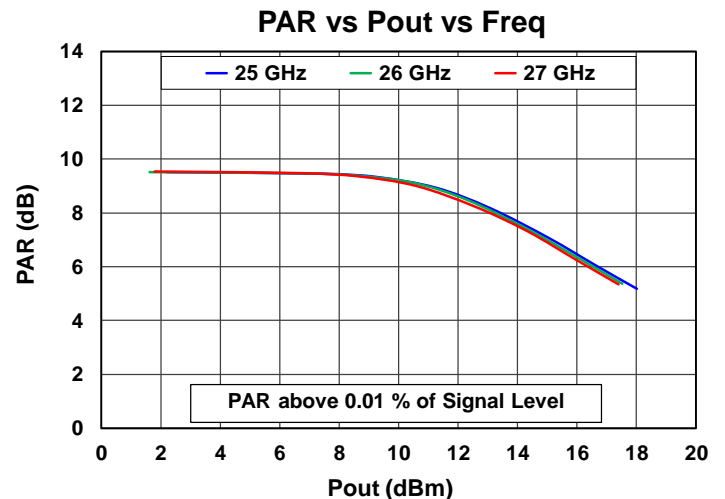
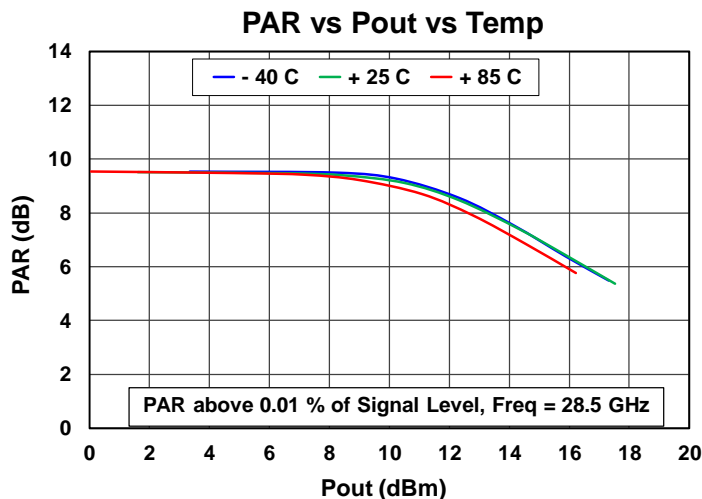
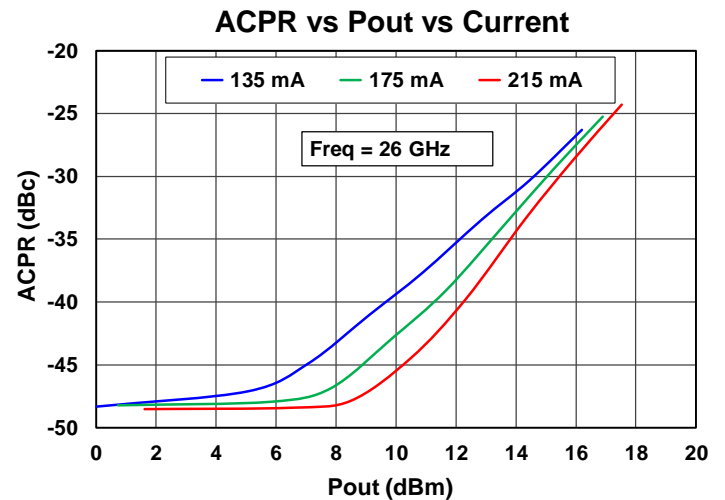
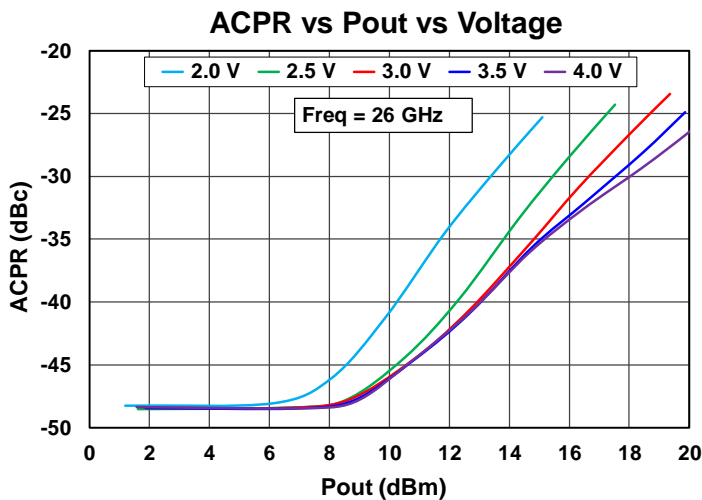
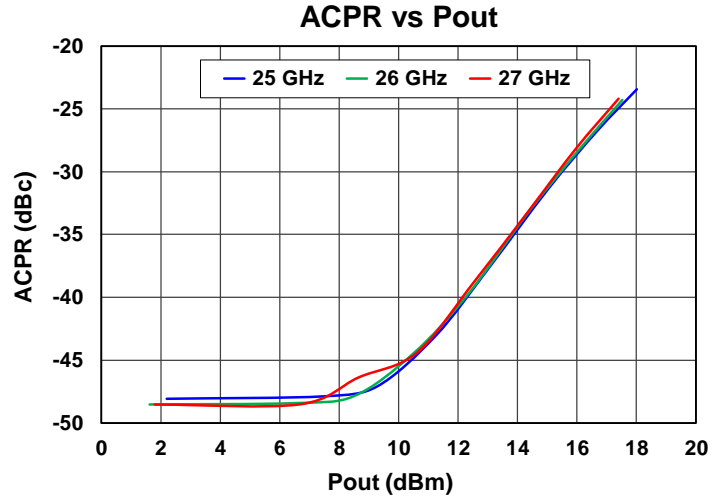
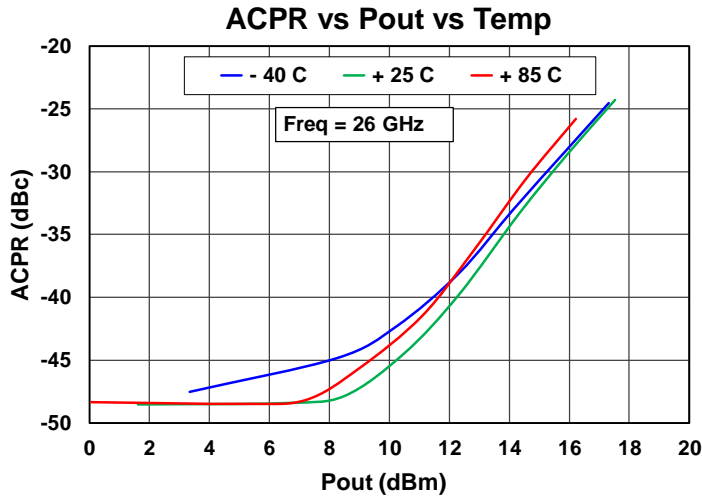

Performance Plots, Modulated Signal, Transmit Path

Test Conditions unless otherwise stated: TXVD = 2.5 V, TXIDQ12 = 215 mA, Source: 400 MHz OFDM, 64 QAM, 25 °C

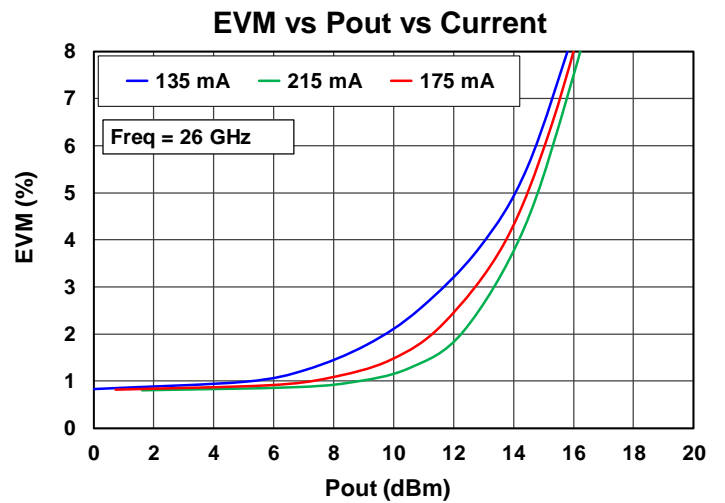
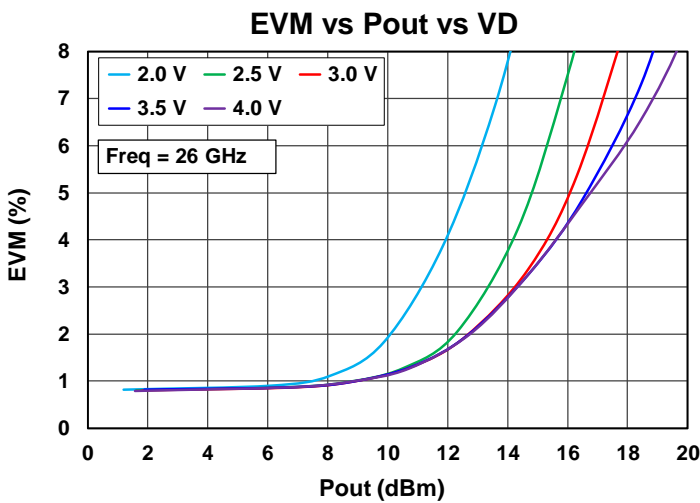
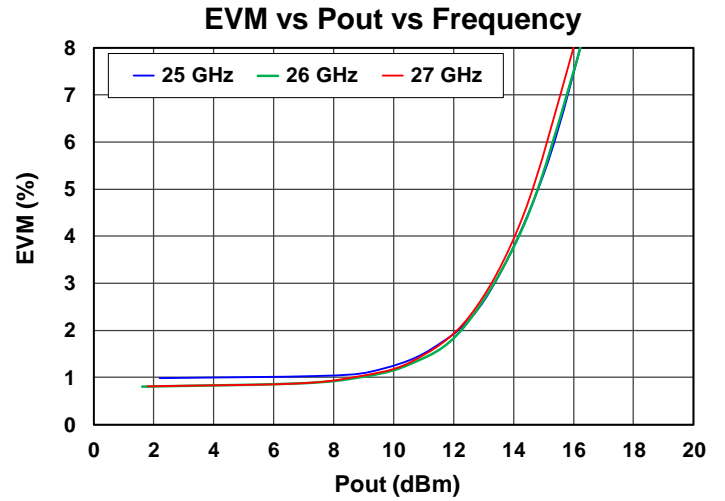
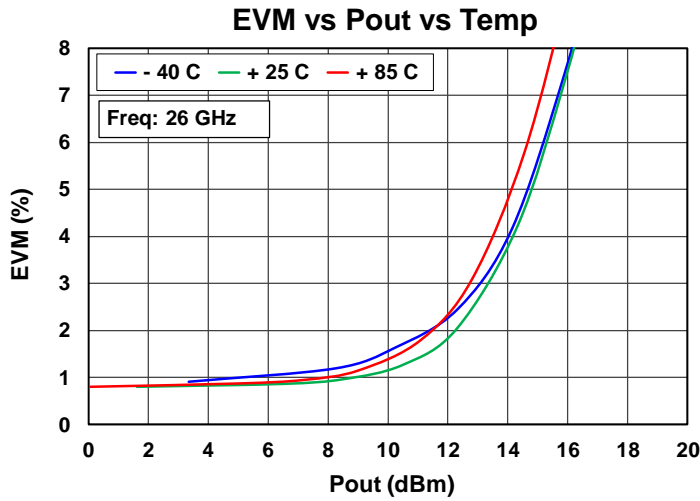

Mechanical Drawings & Pad Descriptions

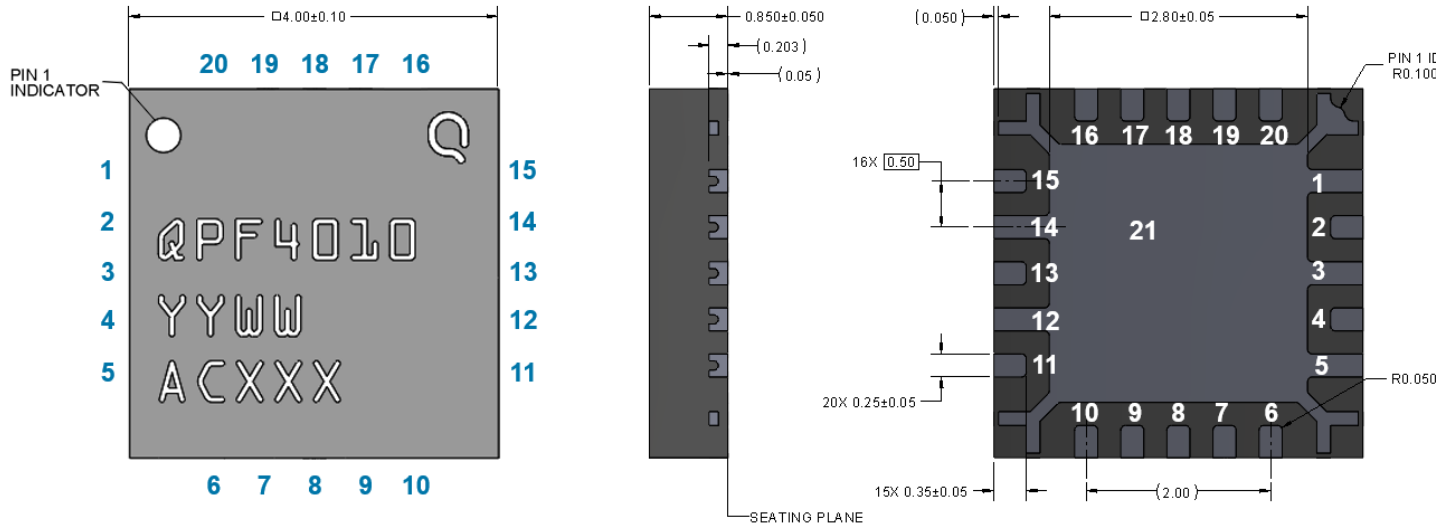

Dimensions in mm

Part package is mold encapsulated with NiPdAu plated lead finish

Part Marking: QPF4010: Part Number; YY: Part Assembly Year; WW: Part Assembly Week, ACXXX: Batch ID

Pin Number	Label	Description
1, 3, 5, 12, 14, 21 (slug)	GND	GROUND
2	TXIN	Transmit Input
4	RXOUT	LNA Output
6	RXVD	LNA Drain Voltage
8	RXADJ	LNA Bias Control, can leave open or connect to GND through a resistor or short to GND, open will get 10mA current, short will get 15 mA of LNA current.
9	SWCTRL	Switch Control
10	SWREF	Switch Control Reference
13	ANT	Antenna
16	VREF	Transmit Power Detector Reference
17	VDET	Transmit Power Detector
18	TXVD	Transmit Drain Voltage
19	TXVG2	Transmit PA VG2 Control
20	TXVG1	Transmit PA VG1 Control
7, 11, 15	N/C	No Internal Connection

Evaluation Board and Assembly

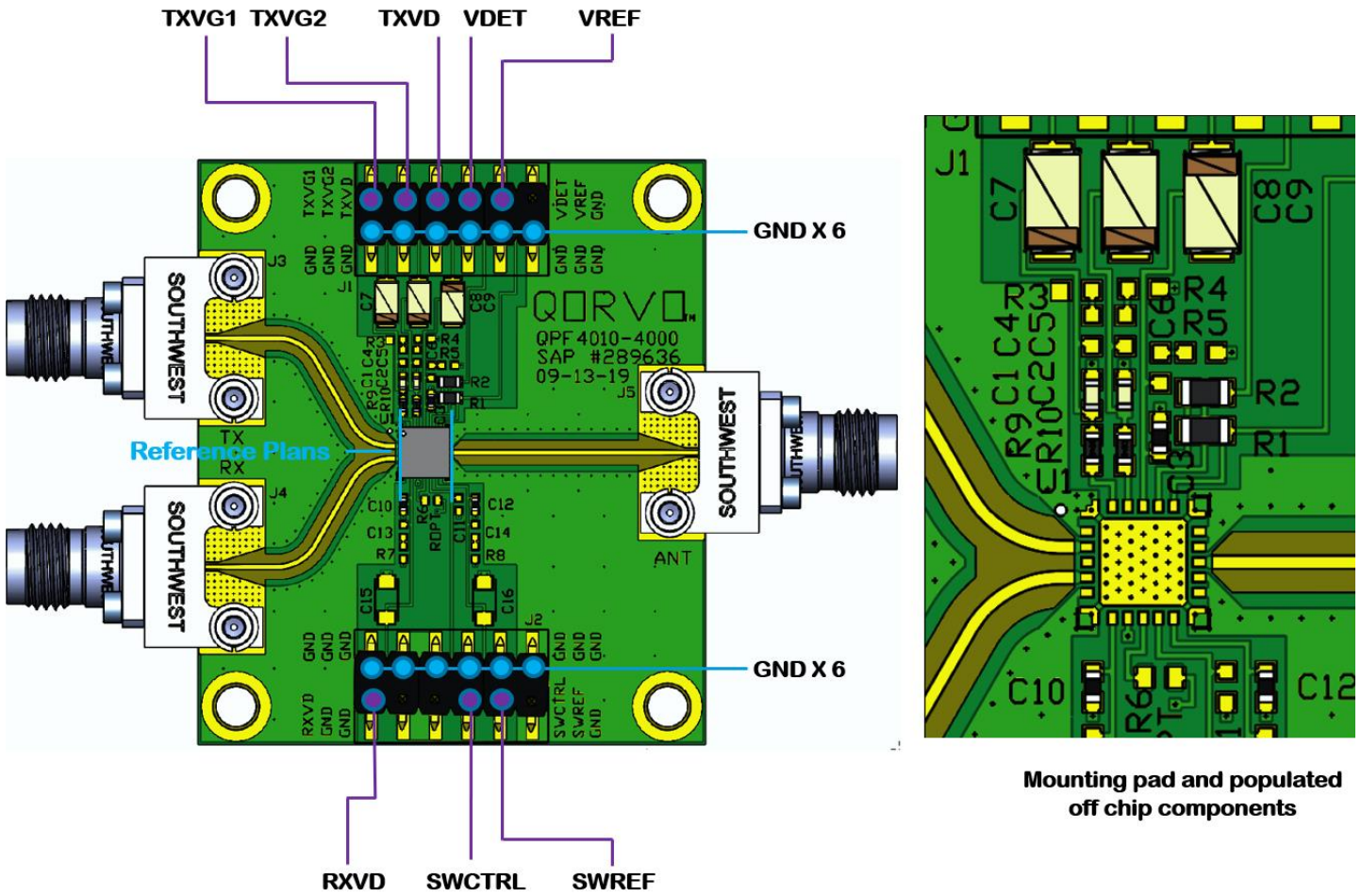

Mounting pad and populated off chip components

RF Layer is 0.008" thick Rogers Corp. RO4003C ($\epsilon_r = 3.35$). Metal layers are 0.5 oz. copper. The microstrip line at the connector interface is optimized for the Southwest Microwave end launch connector 1492-04A-5.

Ref. Des.	Component	Descriptions	Manuf.	Remark
C1, C2	SMT Cap.	CAP, 0402 100 pF +/-10% 16V, X7R	Various	
C3, C10, C12	SMT Cap.	CAP, 0402 1000 pF +/-10% 16V, X7R	Various	
C7, C8, C9	SMT Cap.	CAP, 1206 10 uF +/-10%, TANT - A, 16V	Various	
R1, R2	SMT Res.	RES, 0603 5.1 K, 1%, 1/10W	Various	
R9, R10	SMT Res.	RES, 0402 10 Ohm, 1%, 1/10W	Various	
R6	SMT Res	DNP for 10mA, or short for 15mA LNA current	-	
J3, J4, J5	RF Connectors	End Launch Connector, 1492-04A-5	Southwest Microwave	

Application Circuit

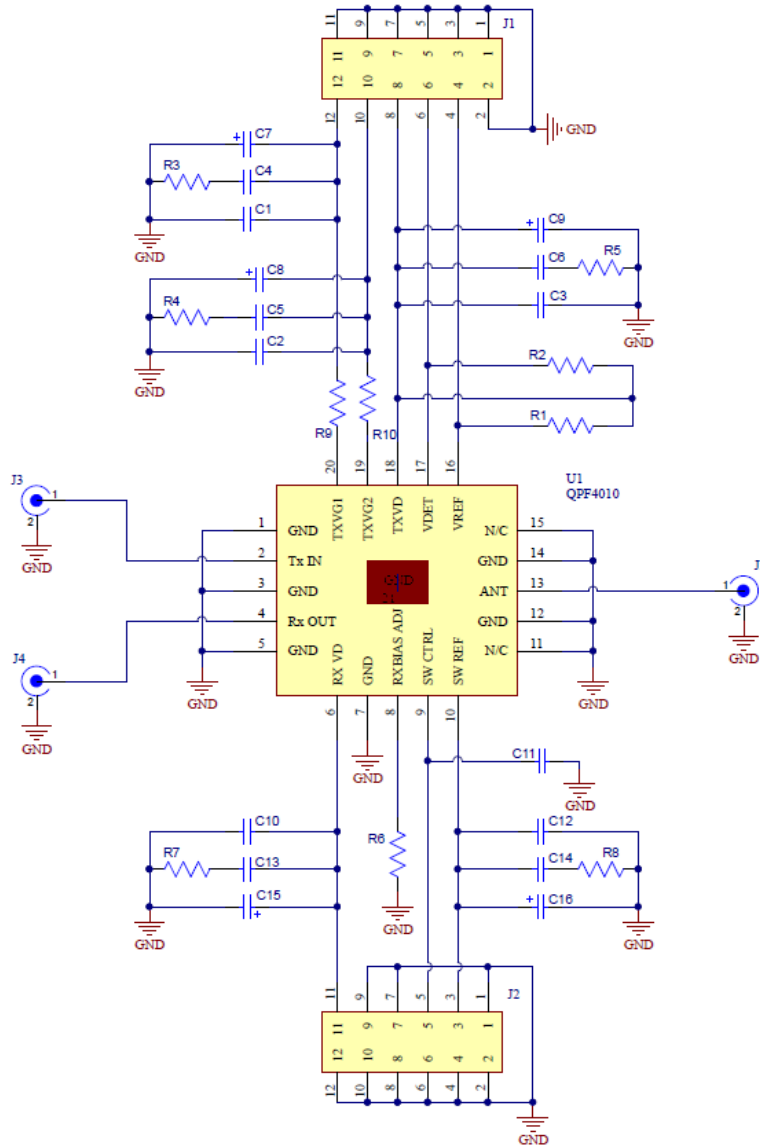

Bias-up Procedure

1. Set TXVD limit to 350 mA, RXVD limit to 30 mA, gate and control supply limit to 10 mA each.
2. Set TXVG1, TXVG2 to -1.5 V
3. Set SWREF = 3.5 V
Set SWCTRL = 3.5 V for RX (or 0 V for TX)
(SWCTRL logic high should be the same as SWREF)
4. Set TXVD = +2.5 V, RXVD = + 3.5 V
5. Adjust TXVG1 and TXVG2 to get TXVD current
Can connect the two pins together
6. Apply RF signal

Bias-down Procedure

1. Turn off RF signal
2. Set TXVG1 and TXVG2 to -1.5 V
3. Set TXVD = 0 V, Set RXVD = 0 V
4. Turn off Drain Supplies
5. Turn off SWCTRL, then SWREF
6. Turn off gate supply

Thermal and Reliability Information

Parameter	Values	Units	Conditions
Thermal Resistance (θ_{JC}), Quiescent, RX	285.7	$^{\circ}\text{C}/\text{W}$	TX off, RX on, RF off $T_{\text{BASE}} = 85^{\circ}\text{C}$ $RXVD = +3.5\text{ V}$, $I_{\text{DQ}} = 10\text{ mA}$, $P_{\text{DISS}} = 0.035\text{ W}$
Channel Temperature (T_{CH}), Quiescent, RX	95	$^{\circ}\text{C}$	
Median Life (T_{M}), RX	3.8E08	hrs	
Thermal Resistance (θ_{JC}), Under Drive, TX	54.9	$^{\circ}\text{C}/\text{W}$	TX on, RX off, Modulated Signal 14 dBm Output. $T_{\text{BASE}} = 85^{\circ}\text{C}$ $V_{\text{D}} = +2.5\text{ V}$, $I_{\text{DRIVE}} = 204\text{ mA}$, $P_{\text{DISS}} = 0.51\text{ W}$
Channel Temperature (T_{CH}), Under Drive, TX	113	$^{\circ}\text{C}$	
Median Life (T_{M}), TX	3.7E07	Hrs	

Notes:

1. Thermal resistance is measured to package backside

Median Lifetime

Test Conditions: $V_{\text{D}} = 4\text{ V}$
Failure Criteria = 10% reduction in $I_{\text{D_MAX}}$

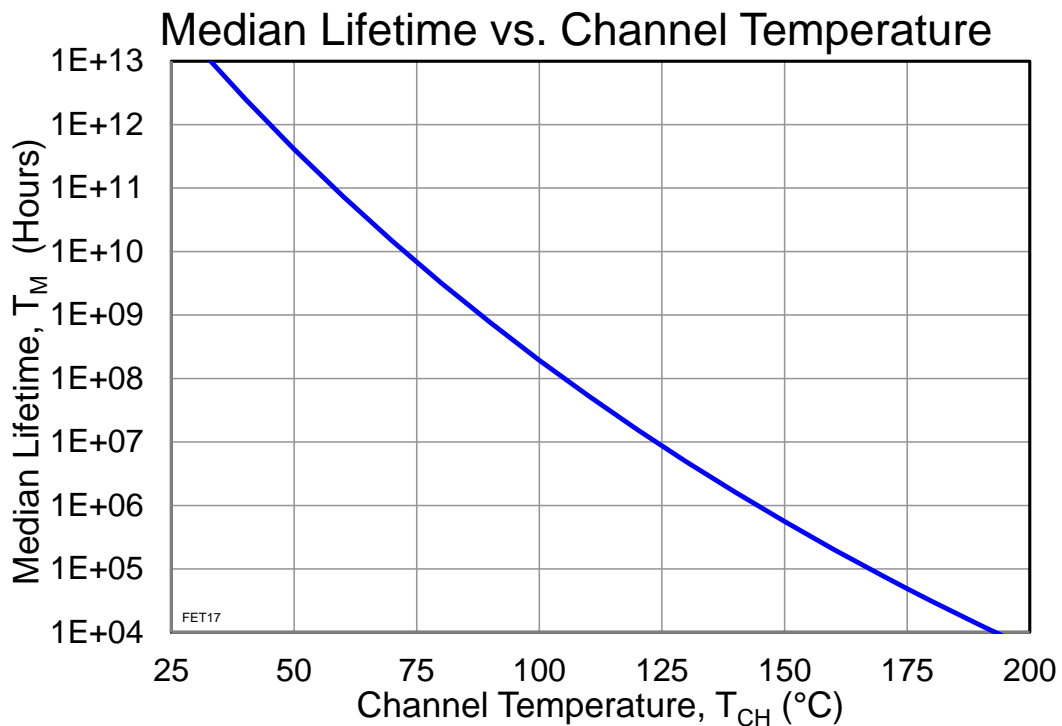

Solderability

- Compatible with the latest version of J-STD-020, Lead-free solder, 260 °C.

Recommended Soldering Temperature Profile

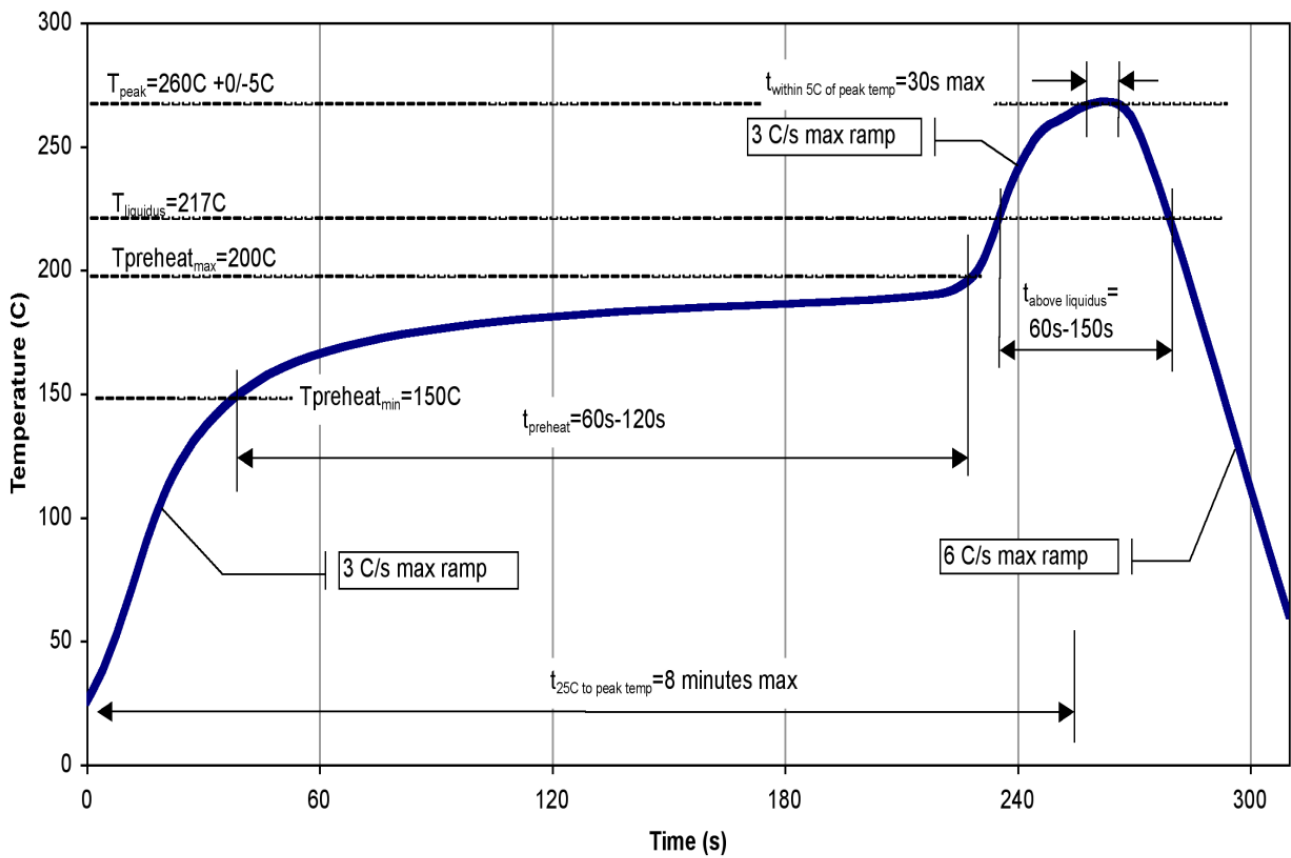

Handling Precautions

Parameter	Rating	Standard
ESD – Human Body Model (HBM)	1A	ESDA / JEDEC JS-001-2012
ESD – Charged Device Model (CDM)	C2b	ESDA / JEDEC JS-002-2014
MSL – Convection Reflow 260 °C	3	JEDEC standard IPC/JEDEC J-STD-020



Caution!
ESD-Sensitive Device

RoHS Compliance

This product is compliant with the 2011/65/EU RoHS directive (Restrictions on the Use of Certain Hazardous Substances in Electrical and Electronic Equipment), as amended by Directive 2015/863/EU.

This product also has the following attributes:

- Lead Free
- Halogen Free (Chlorine, romine)
- Antimony Free
- TBBP-A (C₁₅H₁₂Br₄O₂) Free
- PFOS Free
- SVHC Free

Contact Information

For the latest specifications, additional product information, worldwide sales and distribution locations:

Tel: 1-844-890-8163

Web: www.qorvo.com

Email: customer.support@qorvo.com

Important Notice

The information contained herein is believed to be reliable; however, Qorvo makes no warranties regarding the information contained herein and assumes no responsibility or liability whatsoever for the use of the information contained herein. All information contained herein is subject to change without notice. Customers should obtain and verify the latest relevant information before placing orders for Qorvo products. The information contained herein or any use of such information does not grant, explicitly or implicitly, to any party any patent rights, licenses, or any other intellectual property rights, whether with regard to such information itself or anything described by such information. **THIS INFORMATION DOES NOT CONSTITUTE A WARRANTY WITH RESPECT TO THE PRODUCTS DESCRIBED HEREIN, AND QORVO HEREBY DISCLAIMS ANY AND ALL WARRANTIES WITH RESPECT TO SUCH PRODUCTS WHETHER EXPRESS OR IMPLIED BY LAW, COURSE OF DEALING, COURSE OF PERFORMANCE, USAGE OF TRADE OR OTHERWISE, INCLUDING THE IMPLIED WARRANTIES OF MERCHANTABILITY AND FITNESS FOR A PARTICULAR PURPOSE.**

Without limiting the generality of the foregoing, Qorvo products are not warranted or authorized for use as critical components in medical, life-saving, or life-sustaining applications, or other applications where a failure would reasonably be expected to cause severe personal injury or death.

Copyright 2019 © Qorvo, Inc. | Qorvo is a registered trademark of Qorvo, Inc.

X-ON Electronics

Largest Supplier of Electrical and Electronic Components

Click to view similar products for [RF Front End](#) category:

Click to view products by [Qorvo](#) manufacturer:

Other Similar products are found below :

[SE2622L-R](#) [BGM1032N7E6327XUSA1](#) [LX5586LL](#) [SKY85703-11](#) [LX5586HLL](#) [LX5586ALL](#) [SKY66111-21](#) [SKY65728-11](#) [SKY68000-31](#)
[SKY85308-11](#) [SKY85302-11](#) [SKY65724-11](#) [ADTR1107ACCZ](#) [LMP91051MTX/NOPB](#) [SE5501L-R](#) [QPF4519SR](#) [SE5503A-R](#)
[ADA8282WBCPZ](#) [ADRF5545ABCPZN](#) [ADRF5545ABCPZN-R7](#) [AD8283WBCPZ](#) [AD8284WCSVZ](#) [ADRF5547BCPZN](#)
[ADRF5547BCPZN-R7](#) [ADRF5549BCPZN](#) [ADRF5549BCPZN-R7](#) [HV7350K6-G](#) [SE5516A-R](#) [MCP2030-I/SL](#) [MAX2009ETI+](#)
[MAX2078CTK+](#) [MAX2335ETI+](#) [MAX2678GTB/V+T](#) [MD2131K7-G](#) [MD2134K7-G](#) [RFFM6903TR13](#) [HV7351K6-G](#) [MCP2035-I/ST](#)
[SE2614BT-R](#) [SE2438T-R](#) [SST12LF02-QXCE](#) [SST12LF09-Q3CE](#) [RFX2401C](#) [RFX2402E](#) [SKY85201-11](#) [RFFM4591FTR7](#) [RFFM8211TR7](#)
[RFFM4293TR7](#) [RFFM4203TR7](#) [RFFM5765QTR7](#)