

Product Overview

The QPB7434 is a 47 – 1218 MHz High Gain, Low EIN, Differential RF Optical Receiver for FTTH PON applications. It is a technology leader with an optical input range from -20 dBm to +2 dBm. It runs on a single +5 V supply eliminating the need for an extra ONT supply. The differential input configuration enables direct connection of the Photo Diode to the device. This eliminates the Balun and improves overall EIN of the system.

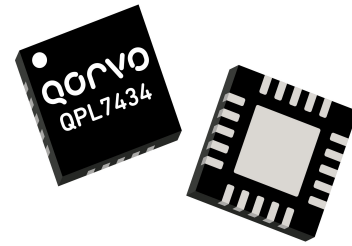

20 Pad 4.0 x 4.0 x 0.85 mm QFN Package

Functional Block Diagram

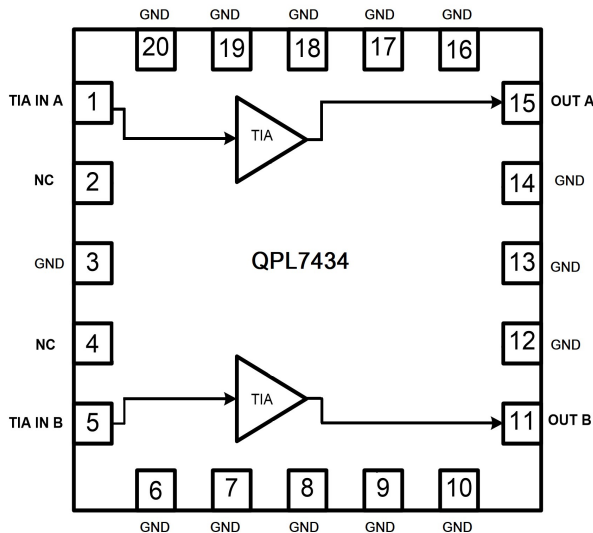

Top View

Key Features

- Optical Input range: +2dBm to -20dBm
- High Gain: > 25dB at 550MHz
- Efficient Power Consumption: 1.0 W at +5 V
- Low Noise: 2.8 pA / $\sqrt{\text{Hz}}$ Equivalent Input Noise Current (EINC)
- High Linearity
- 47 – 1218 MHz Operational Bandwidth
- Convenient QFN Package
- RoHS Compliant

Applications

- FTTH xPON
- DOCSIS 3.1
- Head End CMTS Equipment
- Optical Node
- Cable Modem and Set Top Box

Ordering Information

Part No.	Description
QPL7434SB	Sample Bag with 5 Pieces
QPL7434SR	7" Reel with 100 Pieces
QPL7434TR13	13" Reel with 2500 Pieces
QPL7434PCK-01	EVB with 5 Piece Sample Bag

Absolute Maximum Ratings

Parameter	Rating
Supply Voltage (V _{DD})	+6.0 V
Storage Temperature Range	-40 to +150 °C
Maximum RF input Power	-10dBm

Exceeding any one or a combination of the Absolute Maximum Rating conditions may cause permanent damage to the device. Extended application of Absolute Maximum Rating conditions to the device may red device reliability.

Recommended Operating Conditions

Parameter	Min	Typ	Max	Units
Operating Temperature	-40		+85	°C
Junction Temperature			+160	°C
RF Power Supply Voltage	+4.5	+5.0	+5.5	V

Electrical specifications are measured at specified test conditions. Specifications are not guaranteed over all recommended operating conditions.

Optical to Electrical Receiver Application Specifications

Parameter	Condition ⁽¹⁾	Min	Typ	Max	Unit
Supply Current (I _{DD})	Steady state operation		210		mA
Frequency Range		47		1218	MHz
Optical Gain	At 550MHz. O/E gain is defined by 20*log (Z _I /75)		27		dB
Gain Flatness			±1.5		dB
Tilt	Linear tilt from 45 – 1218 MHz; higher tilt can be achieved by changing components		6		dB
Equivalent Input Noise			2.8		pA / √Hz
Maximum RF Output Level at 547.25 MHz	Input from CATV Optical transmitter with an OMI of 4.5%. The PD responsivity was ~0.96(@1550nm		+15		dBmV/ch
	At 45 MHz		-17		dB
Output Return Loss	At 600 MHz		-15		dB
	At 1218 MHz		-18		dB
MER	90MHz to 850MHz, 0dB tilt, 96 channels, 8MHz spacing. ITU-T Annex A 256 QAM 6.952 Msymbols/s.		32	44	
BER				1E-04	

Notes:

1. Typical performance at these conditions: Temp. = +25 °C, V_{DD} = +5 V, 75Ω system

Optical Input Requirements

Parameter	Unit	Min	Typical	Max
Optical Input Power	dBm	-20		+2
Optical Modulation Index (OMI)	%/ch (79ch)		3.5	4.5
1550 nm PIN Responsivity	mA/mW		0.96	
1550 nm PIN Capacitance	pF		0.35	

Typical Application Schematic

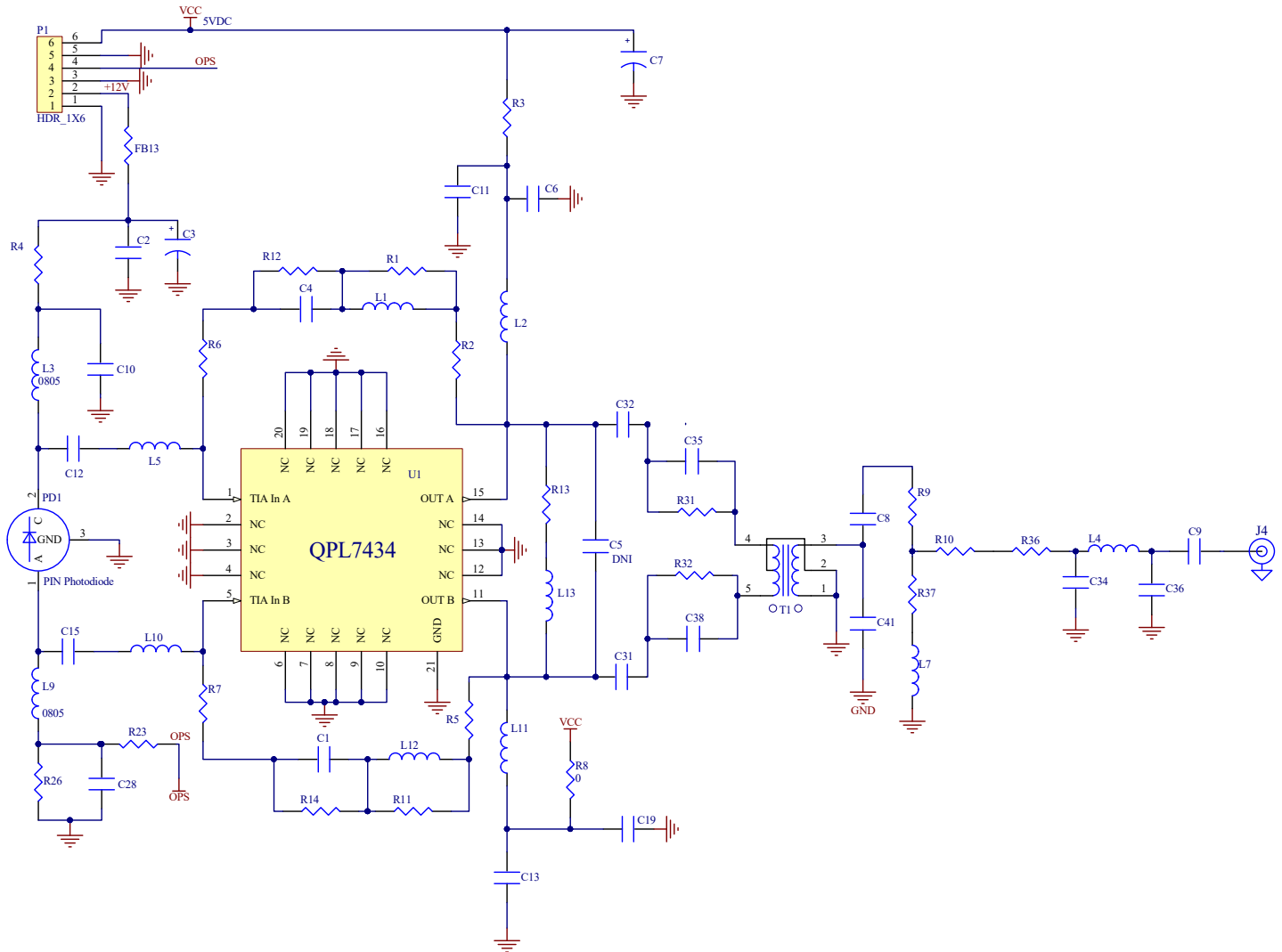

Evaluation Board Assembly Drawing

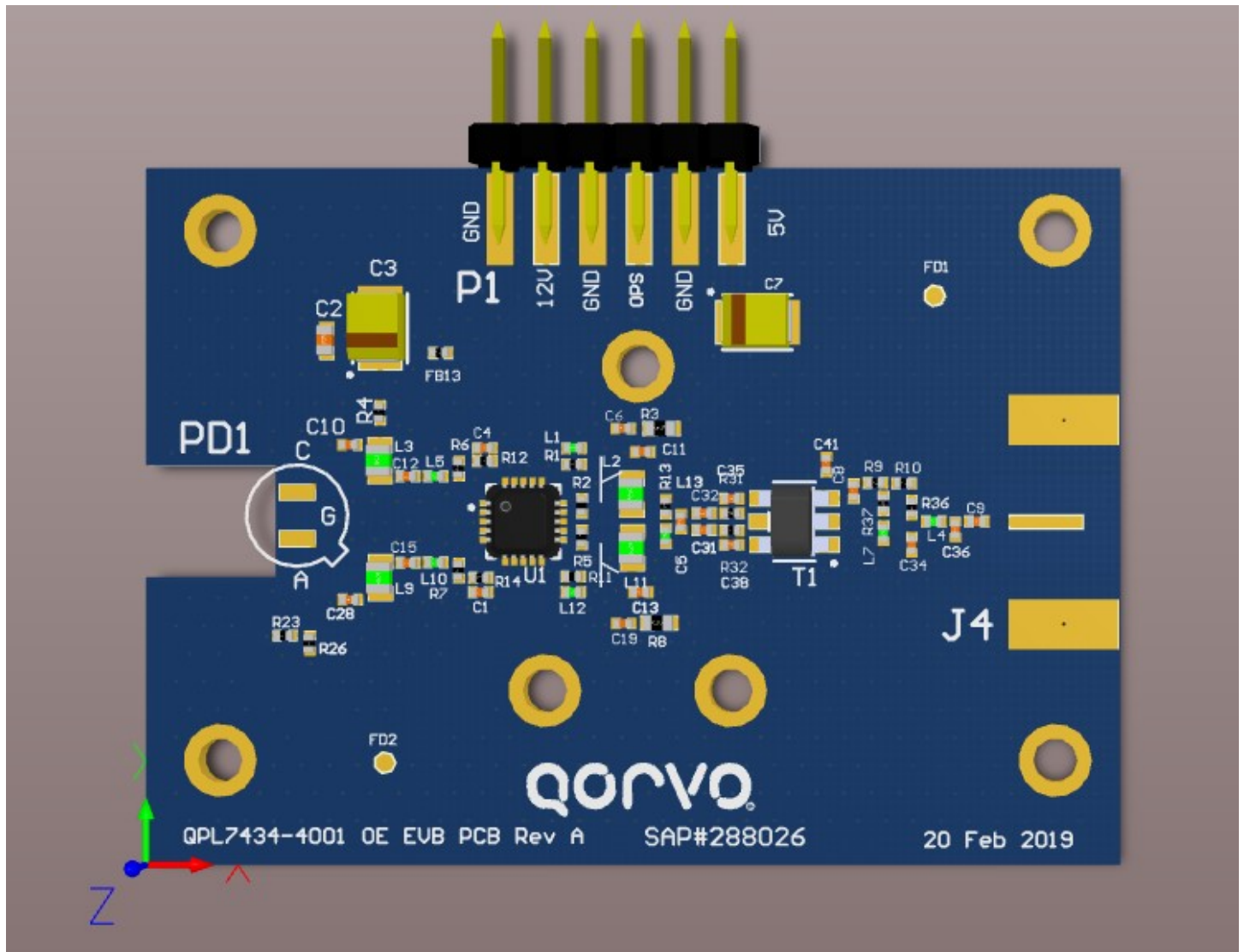

Typical Performance

Test conditions unless otherwise stated: T = +25 °C, V_{DD} = +5 V, OMI=4.5%

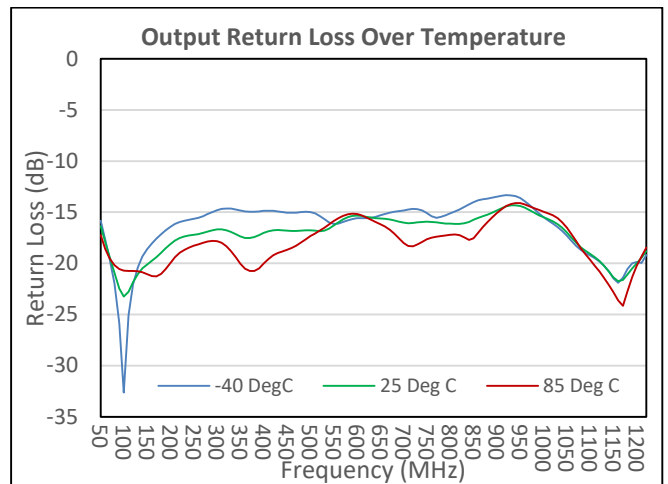
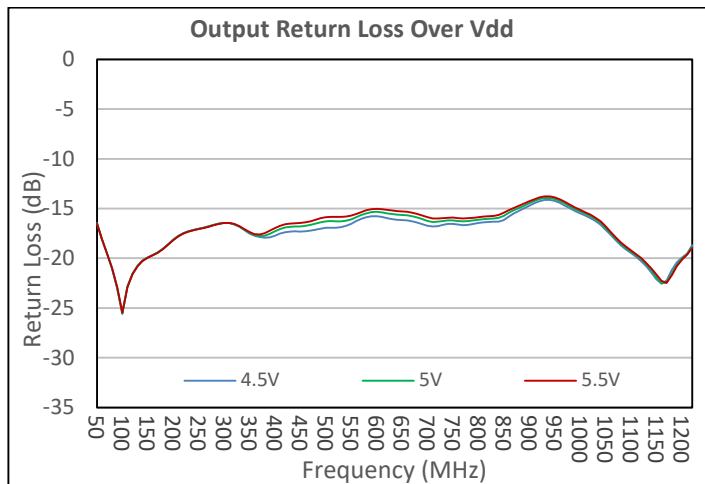
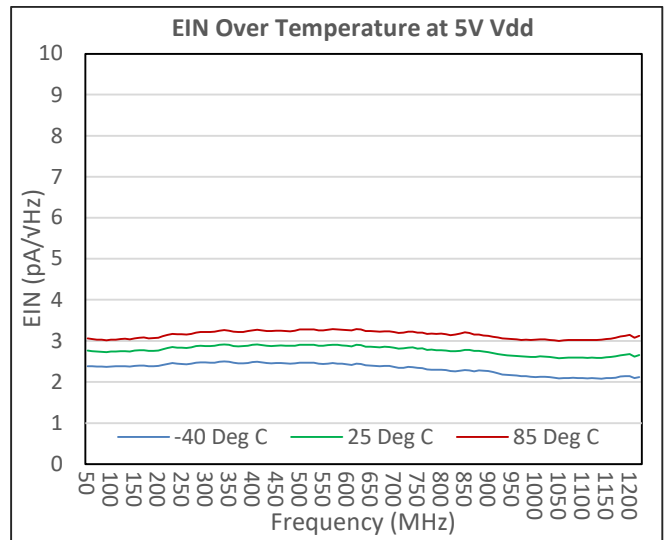
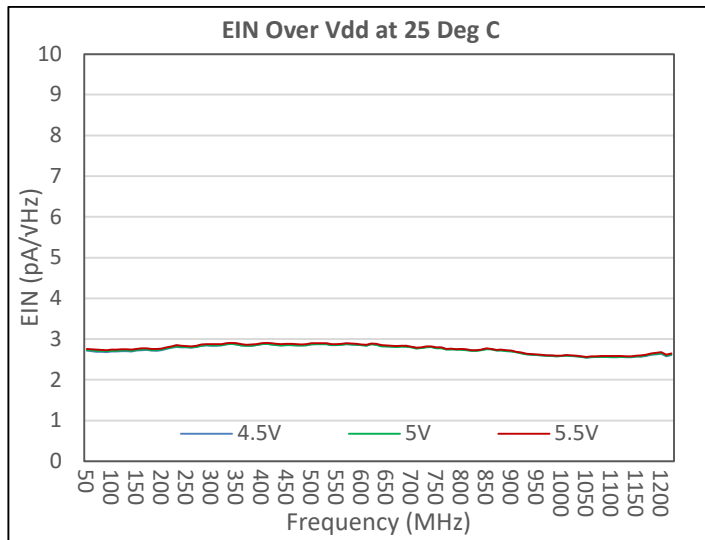
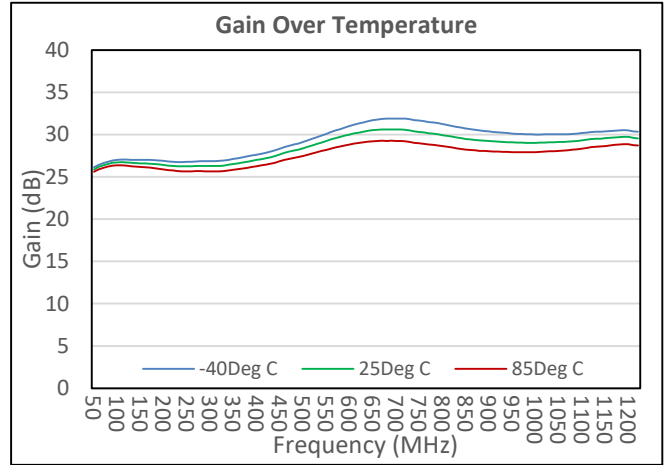
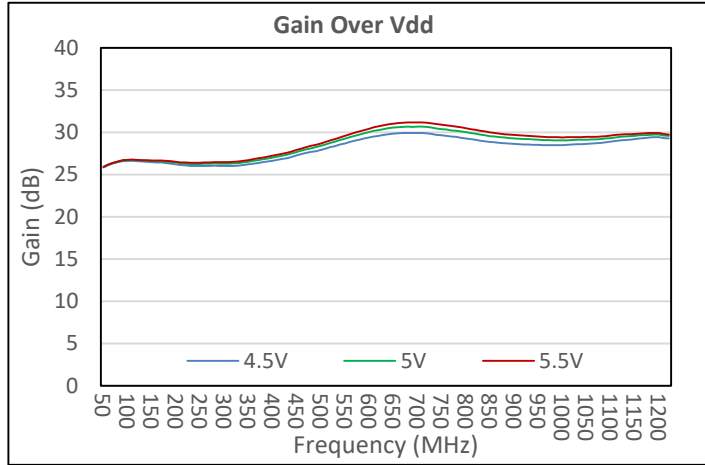

Typical Performance

Test conditions unless otherwise stated: T = +25 °C, V_{DD} = +5 V, OMI=4.5%

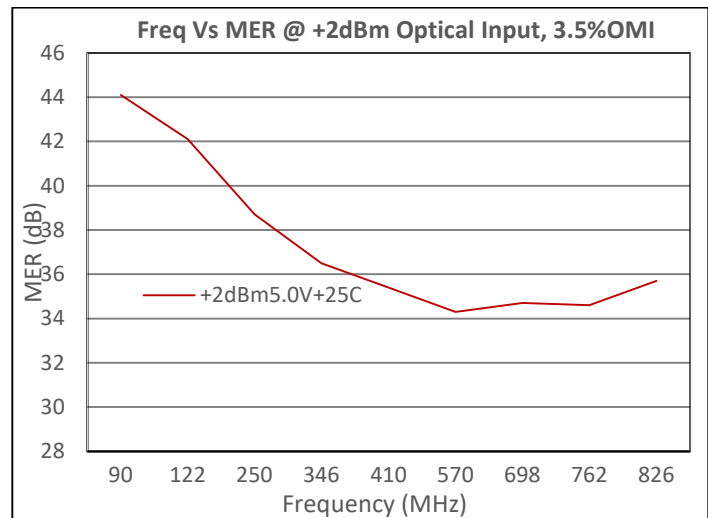
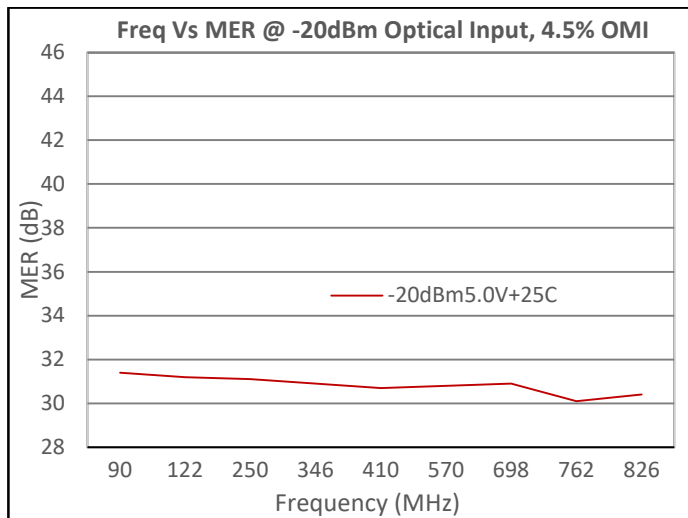
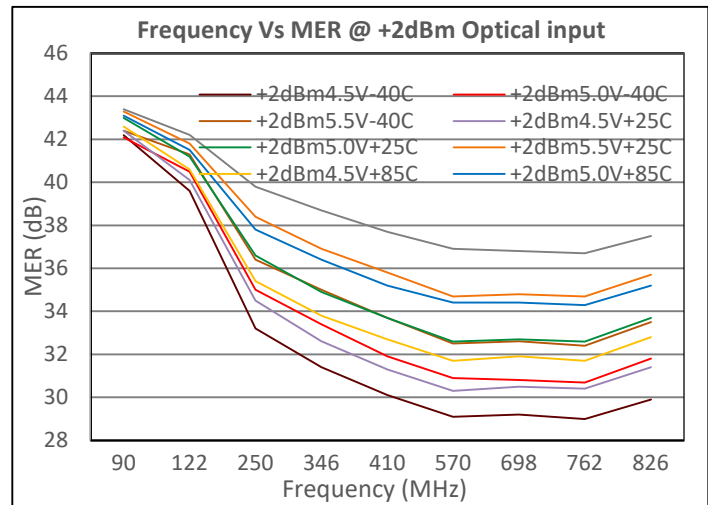
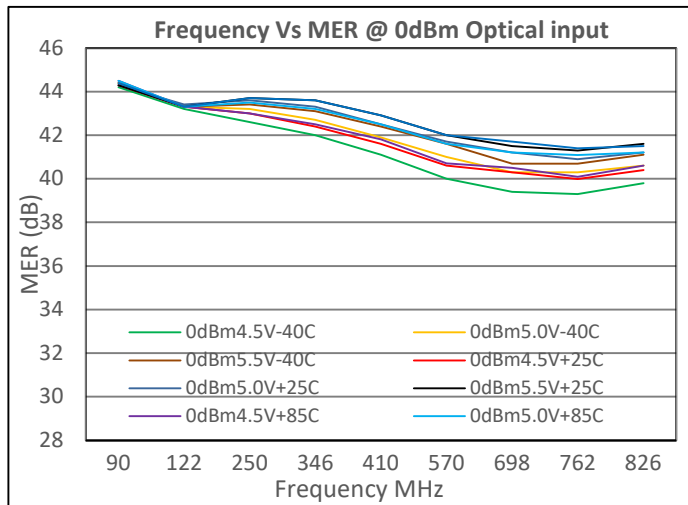
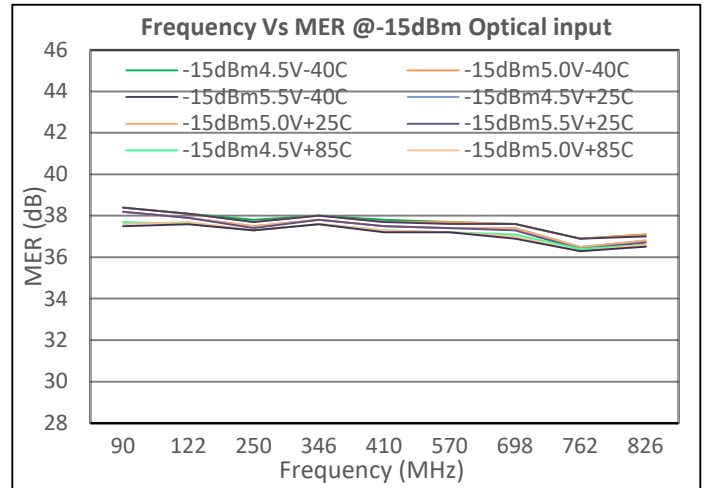
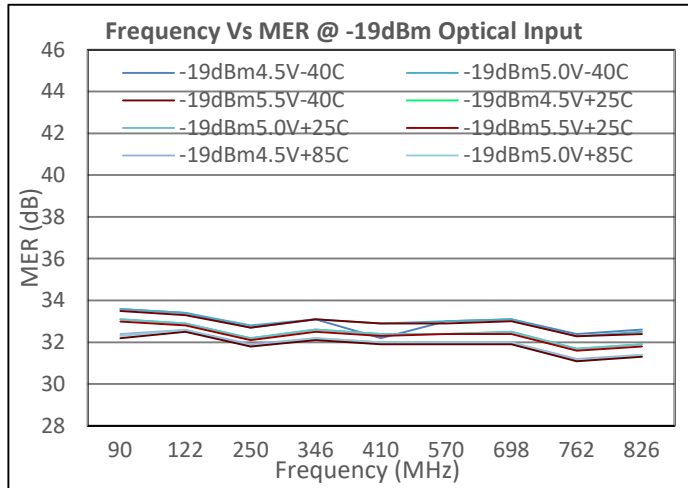

Package Dimensions

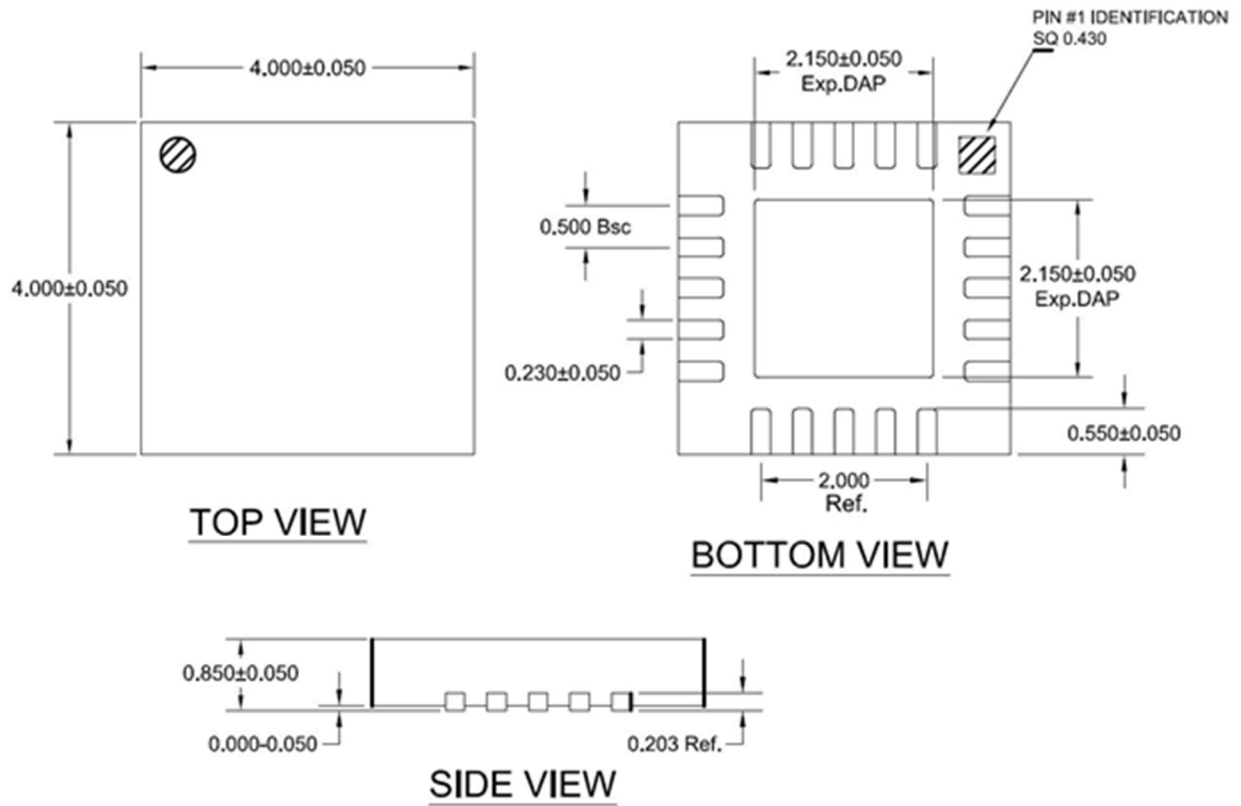

Notes:
1. Dimensions in millimeters

Package Marking

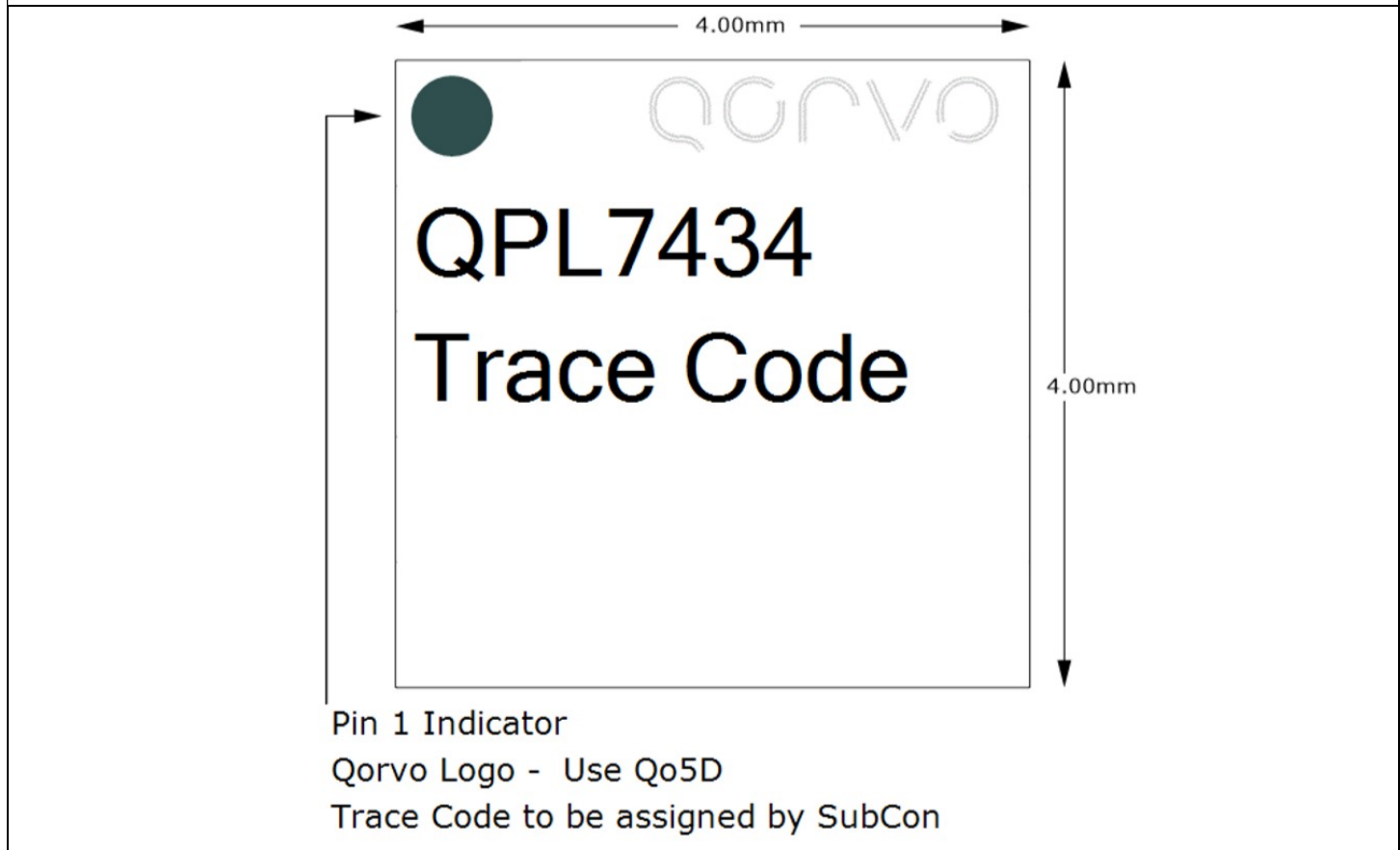

Pin Configuration and Description

Pin	Name	Description
1	TIA IN A	Input to the TIA
2	NC	Not Connected
3	GND	Connect to Ground
4	NC	Not Connected
5	TIA IN B	Input to the TIA
6	GND	Connect to Ground
7	GND	Connect to Ground
8	GND	Connect to Ground
9	GND	Connect to Ground
10	GND	Connect to Ground
11	OUT B	Output of the TIA
12	GND	Connect to Ground
13	GND	Connect to Ground
14	GND	Connect to Ground
15	OUT A	Output of the TIA
16	GND	Connect to Ground
17	GND	Connect to Ground
18	GND	Connect to Ground
19	GND	Connect to Ground
20	GND	Connect to Ground

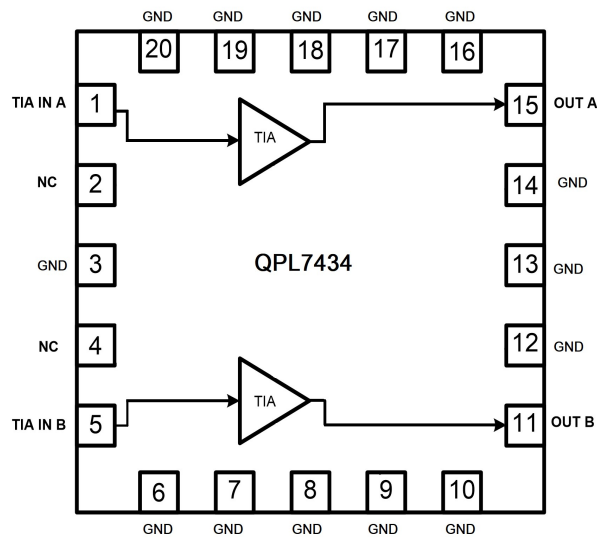

Handling Precautions

Parameter	Rating	Standard
ESD – Human Body Model (HBM)	Class 1A	ESDA / JEDEC JS-001-2012
ESD – Charged Device Model (CDM)	Class C3	JEDEC JESD22-C101F
MSL – Moisture Sensitivity Level	Level 1	IPC/JEDEC J-STD-020



Caution!
 ESD-Sensitive Device

Solderability

Compatible with both lead-free (260°C max. reflow temp.) and tin/lead (245°C max. reflow temp.) soldering processes. Solder profiles available upon request.

Contact plating: Matte Sn

RoHS Compliance

This part is compliant with 2011/65/EU RoHS directive (Restrictions on the Use of Certain Hazardous Substances in Electrical and Electronic Equipment) as amended by Directive 2015/863/EU.

This product also has the following attributes:

- Lead Free
- Halogen Free (Chlorine, Bromine)
- Antimony Free
- TBBP-A (C₁₅H₁₂Br₄O₂) Free
- PFOS Free
- SVHC Free

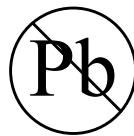

Contact Information

For the latest specifications, additional product information, worldwide sales and distribution locations:

Web: www.qorvo.com

Tel: 1-844-890-8163

Email: customer.support@qorvo.com

Important Notice

The information contained herein is believed to be reliable; however, Qorvo makes no warranties regarding the information contained herein and assumes no responsibility or liability whatsoever for the use of the information contained herein. All information contained herein is subject to change without notice. Customers should obtain and verify the latest relevant information before placing orders for Qorvo products. The information contained herein or any use of such information does not grant, explicitly or implicitly, to any party any patent rights, licenses, or any other intellectual property rights, whether with regard to such information itself or anything described by such information. **THIS INFORMATION DOES NOT CONSTITUTE A WARRANTY WITH RESPECT TO THE PRODUCTS DESCRIBED HEREIN, AND QORVO HEREBY DISCLAIMS ANY AND ALL WARRANTIES WITH RESPECT TO SUCH PRODUCTS WHETHER EXPRESS OR IMPLIED BY LAW, COURSE OF DEALING, COURSE OF PERFORMANCE, USAGE OF TRADE OR OTHERWISE, INCLUDING THE IMPLIED WARRANTIES OF MERCHANTABILITY AND FITNESS FOR A PARTICULAR PURPOSE.**

Without limiting the generality of the foregoing, Qorvo products are not warranted or authorized for use as critical components in medical, life-saving, or life-sustaining applications, or other applications where a failure would reasonably be expected to cause severe personal injury or death.

Copyright 2019 © Qorvo, Inc. | Qorvo is a registered trademark of Qorvo, Inc.

X-ON Electronics

Largest Supplier of Electrical and Electronic Components

Click to view similar products for [RF Development Tools](#) category:

Click to view products by [Qorvo](#) manufacturer:

Other Similar products are found below :

[MAAM-011117](#) [MAAP-015036-DIEEV2](#) [EV1HMC1113LP5](#) [EV1HMC6146BLC5A](#) [EV1HMC637ALP5](#) [EVAL-ADG919EBZ](#) [ADL5363-EVALZ](#) [LMV228SDEVAL](#) [SKYA21001-EVB](#) [SMP1331-085-EVB](#) [EV1HMC618ALP3](#) [EVAL01-HMC1041LC4](#) [MAAL-011111-000SMB](#) [MAAM-009633-001SMB](#) [MASW-000936-001SMB](#) [107712-HMC369LP3](#) [107780-HMC322ALP4](#) [SP000416870](#) [EV1HMC470ALP3](#) [EV1HMC520ALC4](#) [EV1HMC244AG16](#) [MAX2614EVKIT#](#) [124694-HMC742ALP5](#) [SC20ASATEA-8GB-STD](#) [MAX2837EVKIT+](#) [MAX2612EVKIT#](#) [MAX2692EVKIT#](#) [EV1HMC629ALP4E](#) [SKY12343-364LF-EVB](#) [108703-HMC452QS16G](#) [EV1HMC863ALC4](#) [EV1HMC427ALP3E](#) [119197-HMC658LP2](#) [EV1HMC647ALP6](#) [ADL5725-EVALZ](#) [106815-HMC441LM1](#) [EV1HMC1018ALP4](#) [UXN14M9PE](#) [MAX2016EVKIT](#) [EV1HMC939ALP4](#) [MAX2410EVKIT](#) [MAX2204EVKIT+](#) [EV1HMC8073LP3D](#) [SIMSA868-DKL](#) [SIMSA868C-DKL](#) [SKY65806-636EK1](#) [SKY68020-11EK1](#) [SKY67159-396EK1](#) [SKY66181-11-EK1](#) [SKY65804-696EK1](#)