

General Description

The QPL9057 is a flat-gain, high-linearity, ultra-low noise amplifier in a small 2 x 2 mm surface-mount package. The LNA provides a gain flatness of 2.4 dB (peak-to-peak) over a wide bandwidth from 1.5 to 3.8GHz. At 3.5 GHz, the amplifier typically provides 22.8 dB gain, +32 dBm OIP3 at a 50 mA bias setting, and 0.54 dB noise figure. The LNA can be biased from a single positive supply ranging from 3.3 to 5 volts. The device is housed in a green/RoHS-compliant industry-standard 2x2 mm package.

The QPL9057 is internally matched using a high-performance E-pHEMT process and only requires five external components for operation from a single positive supply: an external RF choke and blocking/bypass capacitors and a bias resistor going to pin 1. This LNA integrates a shut-down biasing capability to allow for operation in TDD applications.

The QPL9057 is optimized for linear performance across the 1.5 to 4.2 GHz frequency band but can operate down to 600 MHz.



8 Pin 2X2 mm DFN Package

Product Features

- 0.6-4.2 GHz Operational Bandwidth
- Ultra-low noise figure, 0.54 dB NF @ 3.5 GHz
- >20 dB gain across 1.5 to 3.8 GHz
- Flat 2.4 dB gain variation across 1.7 to 3.8GHz
- Bias adjustable for linearity optimization
- 32 dBm OIP3 at 50mA I_{DD}
- Shut-down mode pin with 1.8V logic
- Unconditionally stable
- Integrated shutdown control pin
- Maintains OFF state with high Pin over drive
- +3.3V to +5.25V single supply; does not require -V_{GG}

Functional Block Diagram

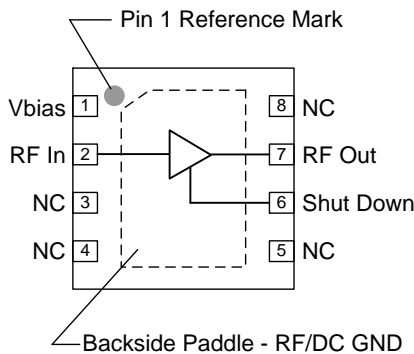

Top View

Applications

- Repeaters / DAS
- Mobile Infrastructure
- LTE / WCDMA / CDMA / GSM
- General Purpose Wireless
- TDD or FDD systems

Ordering Information

Part No.	Description
QPL9057TR7	2500 pieces on a 7" Reel
QPL9057EVB-01	0.6-4.2 GHz Evaluation Board

Absolute Maximum Ratings

Parameter	Rating
Storage Temperature	-65 to 150°C
Supply Voltage (V _{DD})	+7 V
RF Input Power, CW, 50Ω, T=105°C	+27 dBm
RF Input Power, CW, OFF State	+27 dBm

Operation of this device outside the parameter ranges given above may cause permanent damage.

Recommended Operating Conditions

Parameter	Min	Typ	Max	Units
Supply Voltage (V _{DD})	3.3	5.0	5.25	V
T _{CASE}	-40		+105	°C
T _j for >10 ⁶ hours MTTF			+190	°C

Electrical specifications are measured at specified test conditions. Specifications are not guaranteed over all recommended operating conditions.

Electrical Specifications

Test conditions unless otherwise noted: V_{DD} =+5V, Temp=+25°C, 50 Ω system.

Parameter	Conditions	Min	Typ	Max	Units
Operational Frequency Range		600		4200	MHz
Test Frequency			3500		MHz
Gain		21.5	22.8	25.0	dB
Gain Flatness	1700-3800MHz		2.4		dB
Input Return Loss			13		dB
Output Return Loss			12		dB
Noise Figure ⁽¹⁾			0.54	0.90	dB
Output P1dB		14.5	17		dBm
Output IP3	P _{out} =+5 dBm/tone, Δf=1 MHz	29	32		dBm
Shutdown Control Levels, V _{SD}	On state	0		0.63	V
	Off state (Power down)	1.17		V _{DD}	V
LNA Current, I _{DD}	On state		50	70	mA
	Off state (Power down)		3	6	mA
Shutdown Control Current, I _{SD}	V _{SD} ≥ 1.17 V, Off state (Power down)		1		μA
LNA Switch OFF Time	50% V _{PD} to 10% RF output		48		ns
LNA Switch ON Time	50% V _{PD} to 90% RF output		91		ns
Thermal Resistance, θ _{jc}	channel to case			40.6	°C/W

Note:

1) Noise figure data has input trace loss de-embedded.

S-Parameters

Test Conditions: $V_{DD}=+5\text{ V}$, $I_{DD}=50\text{ mA (typ.)}$, $T=+25^{\circ}\text{C}$, Reference planes at device pins

Freq (GHz)	S11 (mag)	S11 (ang)	S21 (mag)	S21 (ang)	S12 (mag)	S12 (ang)	S22 (mag)	S22 (ang)
1.0	0.363	-62.40	12.256	40.27	0.021	-7.21	0.079	-111.83
1.1	0.349	-64.72	11.937	31.80	0.021	-11.15	0.057	-122.11
1.2	0.338	-66.97	11.726	23.70	0.021	-15.27	0.037	-134.96
1.3	0.333	-69.47	11.590	15.99	0.021	-19.39	0.022	-155.81
1.4	0.331	-72.56	11.536	8.54	0.021	-23.49	0.011	153.14
1.5	0.330	-75.77	11.540	1.25	0.021	-27.66	0.016	86.83
1.6	0.332	-79.54	11.620	-5.84	0.020	-31.88	0.025	61.12
1.7	0.337	-83.50	11.751	-12.88	0.020	-36.27	0.034	47.76
1.8	0.345	-88.04	11.924	-19.83	0.020	-40.95	0.042	34.14
1.9	0.354	-92.89	12.173	-26.82	0.019	-45.86	0.050	24.15
2.0	0.365	-98.45	12.460	-33.85	0.019	-51.11	0.054	12.78
2.1	0.376	-104.44	12.798	-41.05	0.019	-56.72	0.058	-1.99
2.2	0.390	-110.49	13.197	-48.32	0.018	-62.58	0.065	-16.74
2.3	0.403	-117.36	13.609	-55.92	0.018	-68.97	0.070	-31.21
2.4	0.420	-124.54	14.058	-63.77	0.017	-76.11	0.077	-47.98
2.5	0.434	-132.38	14.508	-71.91	0.017	-83.90	0.090	-65.73
2.6	0.449	-140.69	14.994	-80.39	0.016	-92.51	0.107	-82.09
2.7	0.463	-149.41	15.403	-89.27	0.016	-101.95	0.126	-97.44
2.8	0.473	-158.73	15.747	-98.57	0.015	-112.06	0.150	-112.41
2.9	0.480	-168.68	15.976	-108.18	0.014	-123.37	0.177	-126.71
3.0	0.481	-179.03	16.074	-118.07	0.014	-135.08	0.210	-139.42
3.1	0.478	170.34	15.996	-128.17	0.014	-147.69	0.242	-151.03
3.2	0.467	159.39	15.696	-138.34	0.013	-160.17	0.270	-162.97
3.3	0.450	148.27	15.228	-148.37	0.013	-172.30	0.300	-174.34
3.4	0.428	137.38	14.633	-158.07	0.013	175.93	0.327	176.01
3.5	0.404	127.03	13.903	-167.45	0.013	165.17	0.347	166.69
3.6	0.381	116.60	13.101	-176.23	0.013	155.28	0.364	157.49
3.7	0.357	106.24	12.271	175.47	0.013	146.87	0.378	149.10
3.8	0.332	96.18	11.474	167.75	0.013	139.24	0.386	141.83
3.9	0.314	83.15	10.730	160.14	0.013	132.16	0.386	134.10
4.0	0.296	74.96	9.999	153.51	0.014	127.06	0.392	128.18
4.1	0.282	66.96	9.308	147.28	0.014	122.02	0.396	122.56
4.2	0.267	58.82	8.687	141.49	0.014	118.13	0.400	117.01
4.3	0.252	51.86	8.143	136.02	0.015	114.50	0.403	112.77
4.4	0.238	45.26	7.647	130.75	0.015	110.83	0.401	108.89
4.5	0.227	39.31	7.182	125.74	0.016	107.90	0.401	104.56
4.6	0.216	32.68	6.770	120.86	0.016	105.34	0.402	100.53
4.7	0.203	26.93	6.392	116.21	0.017	102.88	0.400	96.95
4.8	0.190	20.82	6.056	111.63	0.018	100.30	0.398	93.19
4.9	0.178	15.55	5.740	107.27	0.018	97.92	0.397	89.45
5.0	0.169	10.06	5.448	103.06	0.019	95.81	0.396	86.01
5.1	0.156	4.12	5.181	98.77	0.020	93.45	0.394	82.07
5.2	0.141	-1.67	4.943	94.71	0.020	91.54	0.394	78.96
5.3	0.132	-7.43	4.722	90.73	0.021	89.25	0.391	75.43
5.4	0.122	-14.31	4.515	86.71	0.022	87.22	0.388	71.86
5.5	0.112	-22.69	4.315	82.73	0.023	84.51	0.388	68.09
5.6	0.102	-32.31	4.133	78.92	0.024	82.03	0.388	65.06
5.7	0.093	-41.13	3.971	75.14	0.025	79.79	0.385	61.53
5.8	0.090	-51.19	3.818	71.35	0.025	77.65	0.389	57.47
5.9	0.089	-63.48	3.666	67.57	0.026	75.64	0.389	54.11
6.0	0.091	-76.48	3.537	63.84	0.027	73.59	0.387	50.63

Noise Parameters

Test conditions: $V_{DD}=+5\text{ V}$, $I_{DD}=50\text{ mA}$ (typ.), $T=+25^{\circ}\text{C}$, Reference planes at device pins

Freq (GHz)	NF _{min} (dB)	Gamma Opt (mag)	Gamma Opt (deg)	Rn (Ω)
2.0	0.246	0.283	47.66	0.076
2.2	0.261	0.231	68.48	0.061
2.4	0.279	0.213	81.15	0.054
2.6	0.315	0.198	92.03	0.050
2.8	0.334	0.191	103.07	0.046
3.0	0.408	0.146	110.96	0.053
3.2	0.413	0.189	117.92	0.044
3.4	0.450	0.162	131.84	0.045
3.5	0.491	0.131	143.21	0.048
3.6	0.531	0.157	152.91	0.043
4.0	0.599	0.099	172.03	0.050
4.2	0.634	0.142	-176.97	0.051
4.4	0.686	0.142	-160.26	0.051
4.6	0.681	0.149	-153.24	0.057
4.8	0.775	0.102	-141.49	0.069
5.0	0.817	0.138	-132.51	0.076
5.2	0.863	0.149	-131.67	0.079
5.4	0.957	0.134	-130.72	0.092
5.6	1.051	0.185	-114.16	0.107
5.8	1.184	0.178	-113.36	0.109

QPL9057EVB-01 Evaluation Board

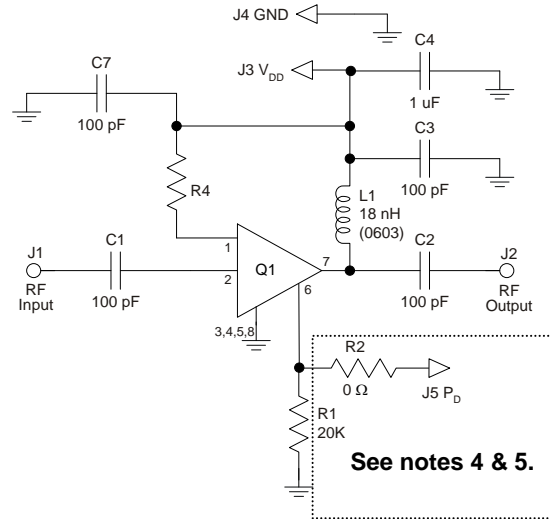
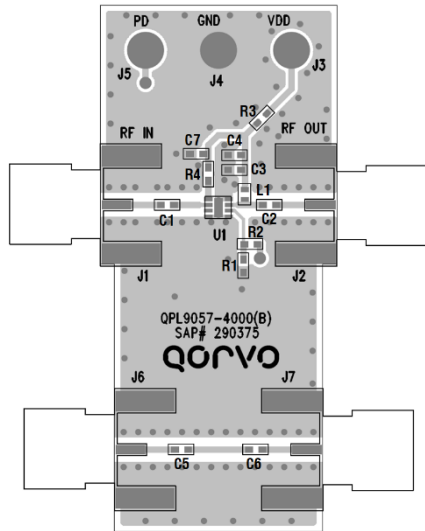

Notes:

1. See Evaluation Board PCB Information section for material and stack-up.
2. R3 (0 Ω jumper) is not shown on the schematic and may be replaced with copper trace in the target application layout.
3. All components are of 0402 size unless stated on the schematic.
4. For TDD Applications: R1 = 20K & R2 = 0 Ω
5. For FDD Applications: R1 = 20K 'OR' Pin 6 tied to ground. R2 = DNP/Omitted
6. A through line is included on the evaluation board to de-embed the board losses.
7. R4 sets the current draw. Can be changed for the desired bias point.

Bill of Material – QPL9057EVB-01

Reference Des.	Value	Description	Manuf.	Part Number
PCB	--	Printed Circuit Board	Qorvo	290375
U1	--	Amplifier, Ultra-Low Noise, Flat Gain	Qorvo	QPL9057
R4	5.1 K	Resistor, 0402, 5%, 1/16W	various	
R1	20 K	Resistor, 0402, 5%, 1/16W	various	
R2, R3	0 Ω	Resistor, 0402, 5%, 1/16W	various	
L1	18 nH	Inductor, 0402, 2%,	Coilcraft	0402CS-18NXG
C4	1.0 μ F	Capacitor, 0402, 10%, 10V, X5R	various	
C1, C2, C3, C5, C6	100 pF	Capacitor, 0402, 5%, 50V, NPO/COG	various	

Typical Performance – QPL9057EVB-01

Test conditions unless otherwise noted: $V_{DD}=+5\text{ V}$, $I_{DD}=50\text{ mA}$ (typ.), $\text{Temp}=+25^\circ\text{C}$

Parameter	Conditions	Typical Values			Units
Frequency		1800	2600	3500	MHz
Gain		21.0	22.7	22.8	dB
Input Return Loss		7.8	8.0	13.0	dB
Output Return Loss		31.9	15.6	12.0	dB
Output P1dB		17.1	17.1	17.0	dBm
OIP3	$P_{out}=+5\text{ dBm/ tone}$, $\Delta f=1\text{ MHz}$	33.8	37.8	32.0	dBm
Noise figure	EVB input trace loss de-embedded	0.50	0.47	0.54	dB

Performance Plots – QPL9057EVB-01

Test conditions unless otherwise noted: $V_{DD}=+5\text{ V}$, $I_{DD}=50\text{ mA}$, $\text{Temp}=+25^\circ\text{C}$. Noise figure data has input trace loss de-embedded.

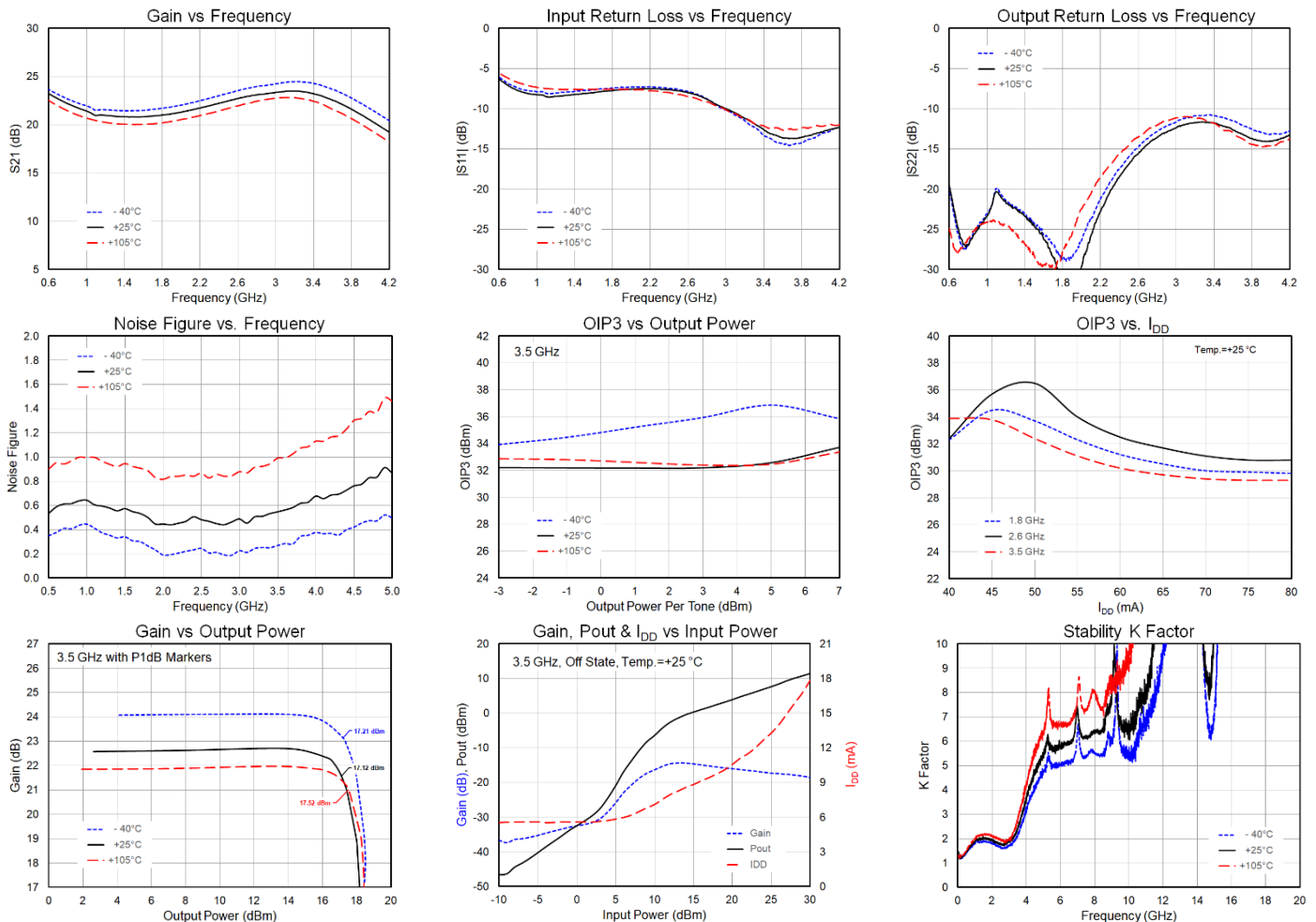

Typical Performance – $V_{DD} +3.3\text{ V}$, $R_4\ 2.49\text{ K}\Omega$

Test conditions unless otherwise noted: $V_{DD}=+3.3\text{ V}$, $I_{DD}=50\text{ mA}$ (typ.), Temp= $+25^\circ\text{C}$

Parameter	Conditions	Typical Values			Units
Frequency		1800	2600	3500	MHz
Gain		20.6	22.1	22.7	dB
Input Return Loss		8.0	8.4	12.5	dB
Output Return Loss		29.4	16.1	12.8	dB
Output P1dB		17.7	16.2	157	dBm
OIP3	$P_{out}=+5\text{ dBm/tone}$, $\Delta f=1\text{ MHz}$	32.4	37.0	32.5	dBm
Noise figure	EVB input trace loss de-embedded	0.48	0.50	0.60	dB

Performance Plots – $V_{DD} +3.3\text{ V}$, $R_4\ 2.49\text{ K}\Omega$

Test conditions unless otherwise noted: $V_{DD}+3.3\text{ V}$, $I_{DD}\ 50\text{mA}$, Temp $+25^\circ\text{C}$. Noise figure data has input trace loss de-embedded.

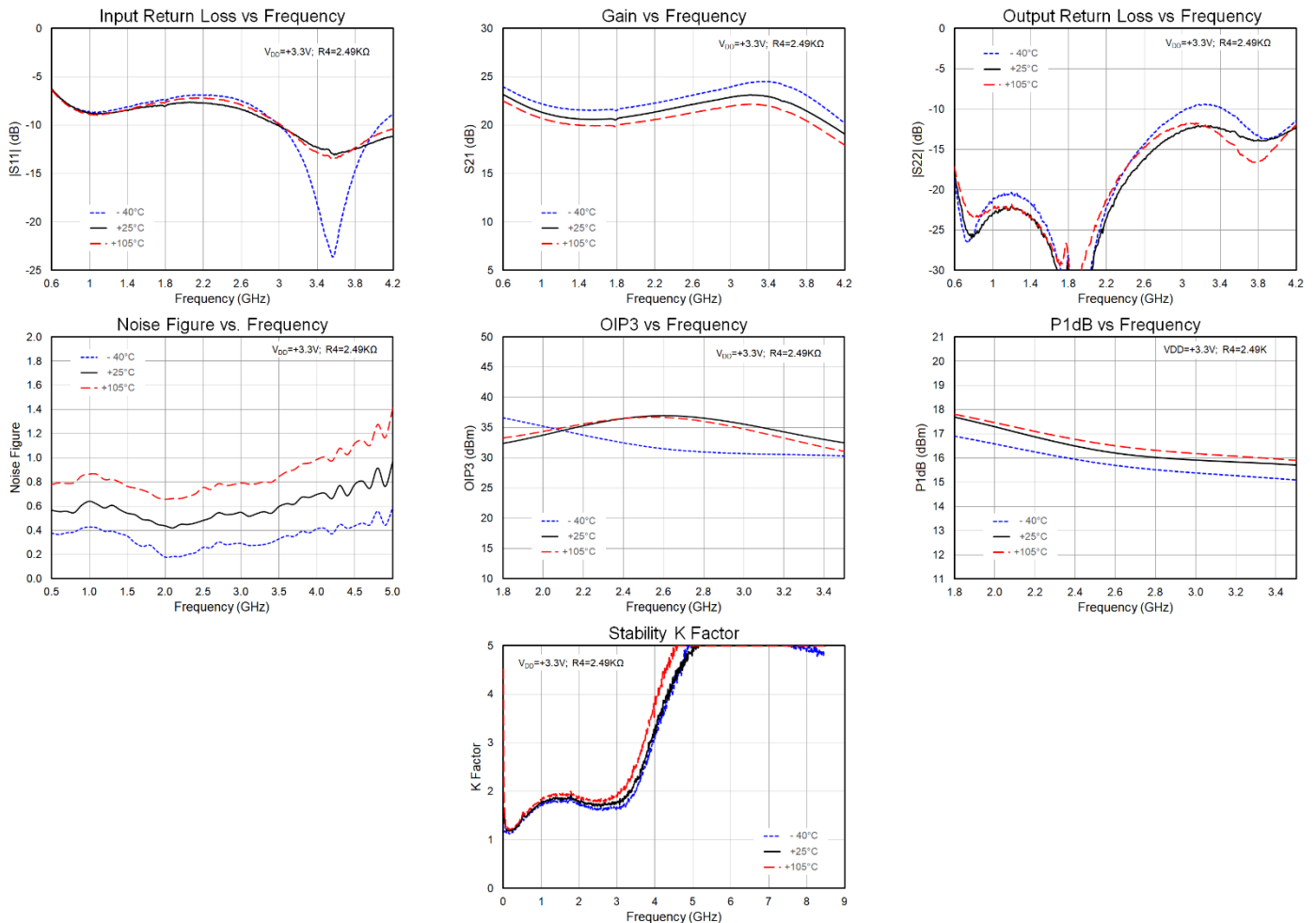

Pin Configuration and Description

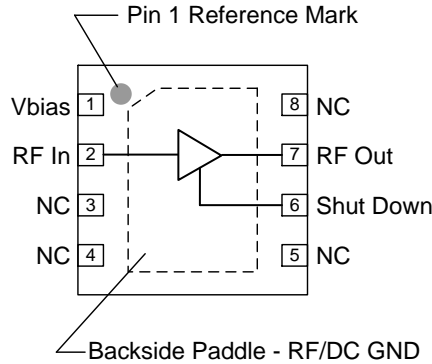

Pin No.	Label	Description
1	Vbias	Sets the I_{DQ} bias point for the device.
2	RF In	RF Input pin. A DC Block is required.
6	Shut Down	$V_{SD} \geq 1.17V$ turns off the device. If the pin is pulled to ground or driven with a voltage $\leq 0.63V$, then the device will operate under LNA ON state.
7	RF Out / DC Bias	RF Output pin. DC bias will also need to be injected through a RF bias choke/inductor for operation.
3, 4, 5, 8	NC	No electrical connection. Provide grounded land pads for PCB mounting integrity.
Backside Paddle	RF/DC GND	RF/DC ground. Use recommended via hole pattern to minimize inductance and thermal resistance; see PCB Mounting Pattern for suggested footprint.

Evaluation Board PCB Information

Qorvo PCB 290375 Material and Stack-up

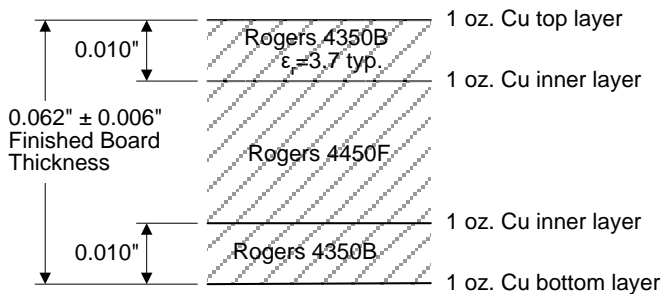

50 ohm line dimensions: width = 0.020", spacing = 0.032"

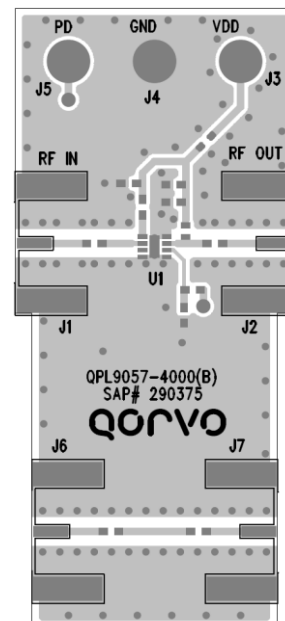

Mechanical Information

Package Marking and Dimensions

Marking: Part number – 9057
Trace code – XXXX

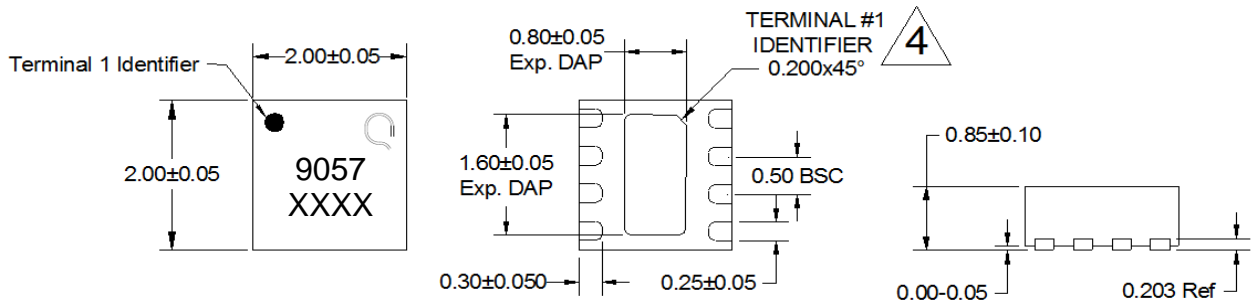

Notes:

1. All dimensions are in millimeters. Angles are in degrees.
2. Except where noted, this part outline conforms to JEDEC standard MO-220, Issue E (Variation VGGC) for thermally enhanced plastic very thin fine pitch dual flat no lead package (DFN).
3. Dimension and tolerance formats conform to ASME Y14.4M-1994.
4. The terminal #1 identifier and terminal numbering conform to JESD 95-1 SPP-012.

PCB Mounting Pattern

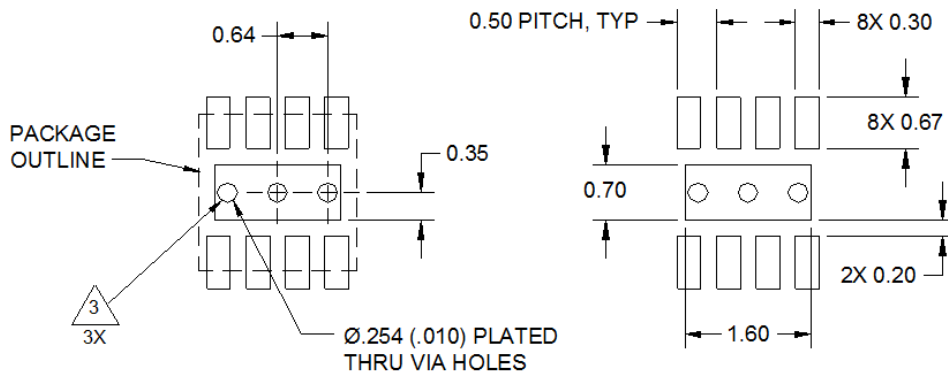

Notes:

1. All dimensions are in millimeters. Angles are in degrees.
2. Use 1 oz. copper minimum for top and bottom layer metal.
3. Via holes are required under the backside paddle of this device for proper RF/DC grounding and thermal dissipation. We recommend a 0.35 mm (#80/.0135") diameter bit for drilling via holes and a final plated thru diameter of 0.25 mm (0.01 ").
4. Ensure good package backside paddle solder attach for reliable operation and best electrical performance.

Tape and Reel Information – Carrier and Cover Tape Dimensions

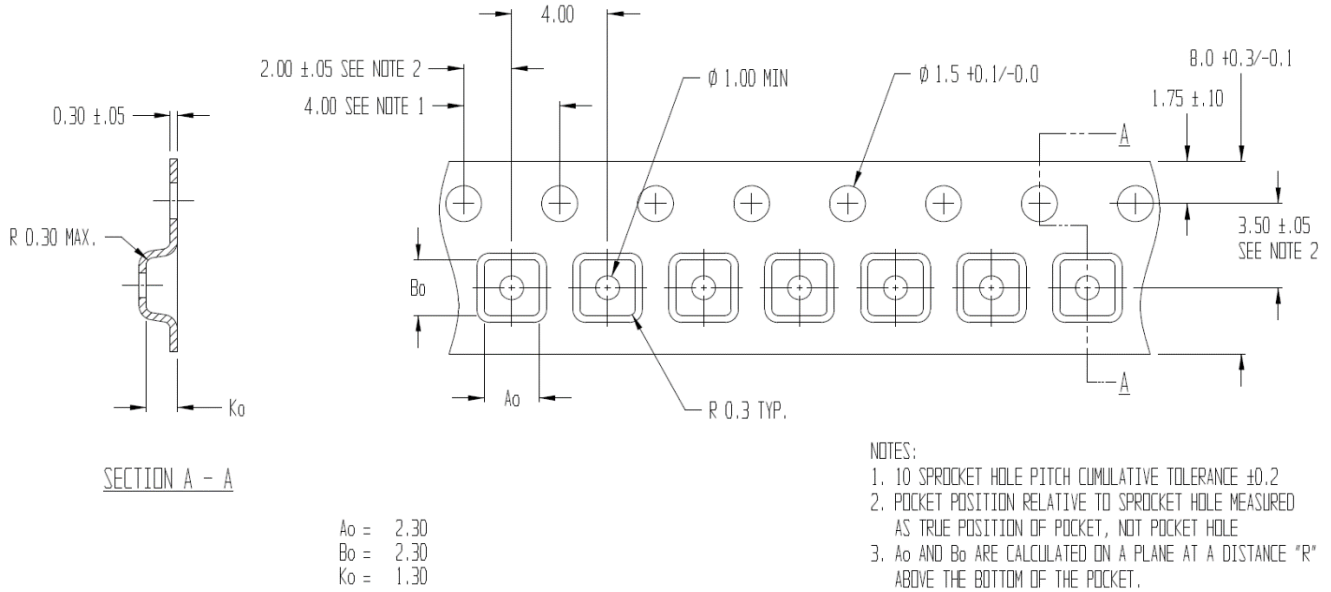

Feature	Measure	Symbol	Size (in)	Size (mm)
Cavity	Length	A0	0.091	2.30
	Width	B0	0.091	2.30
	Depth	K0	0.039	1.30
	Pitch	P1	0.157	4.00
Centerline Distance	Cavity to Perforation - Length Direction	P2	0.079	2.00
	Cavity to Perforation - Width Direction	F	0.138	3.50
Cover Tape	Width	C	0.213	5.40
Carrier Tape	Width	W	0.315	8.00

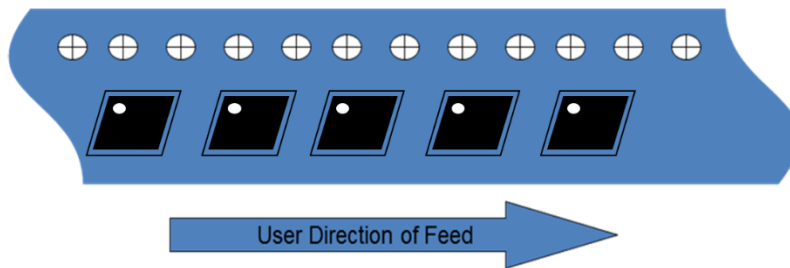

Tape and Reel Information – Reel Dimensions

Standard T/R size = 2,500 pieces on a 7" reel.

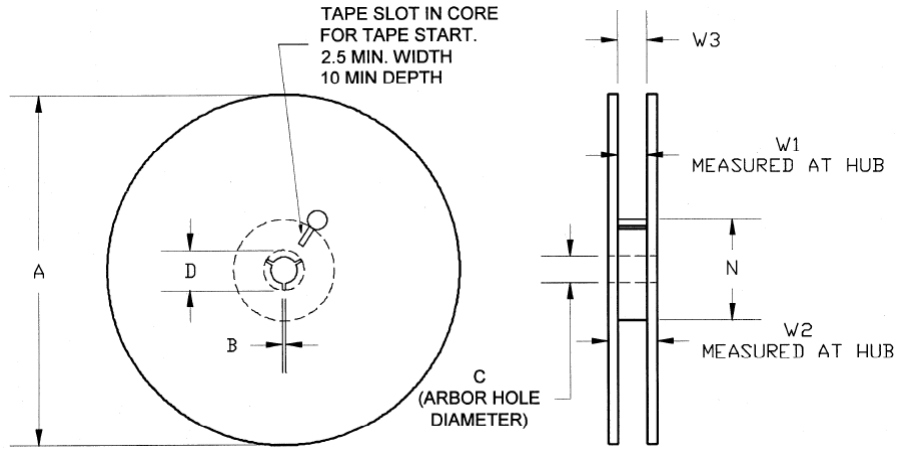

Feature	Measure	Symbol	Size (in)	Size (mm)
Flange	Diameter	A	6.969	177.00
	Thickness	W2	0.559	14.20
	Space Between Flange	W1	0.346	8.80
Hub	Outer Diameter	N	2.283	58.00
	Arbor Hole Diameter	C	0.512	13.00
	Key Slit Width	B	0.079	2.00
	Key Slit Diameter	D	0.787	20.00

Tape and Reel Information – Tape Length and Label Placement

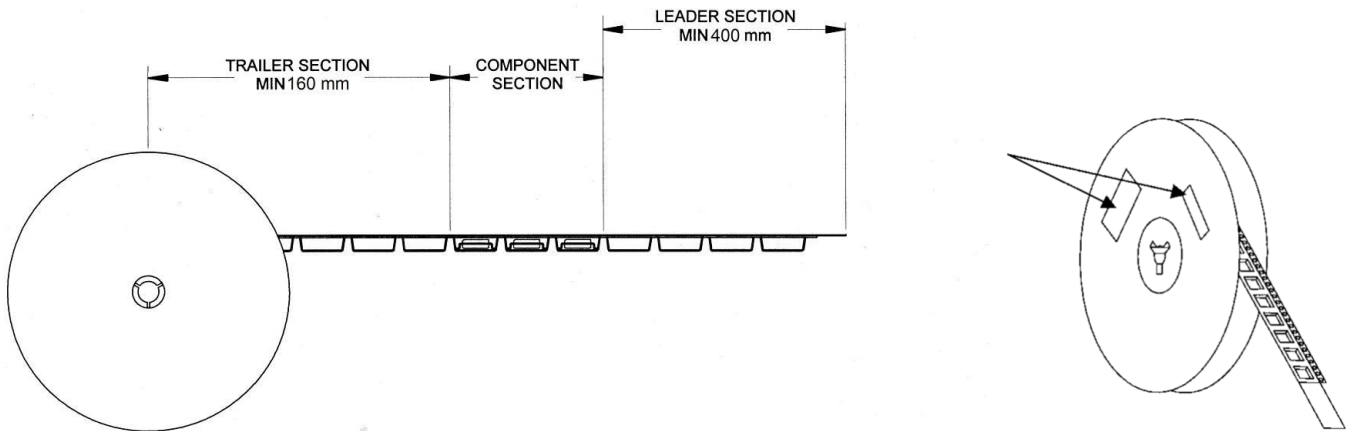

- Notes:
1. Empty part cavities at the trailing and leading ends are sealed with cover tape. See EIA 481-1-A.
 2. Labels are placed on the flange opposite the sprockets in the carrier tape.

Handling Precautions

Parameter	Rating	Standard
ESD – Human Body Model (HBM)	Class 1B	ESDA / JEDEC JS-001-2014
ESD – Charged Device Model (CDM)	Class C3	ESDA / JEDEC JS-002-2014
MSL – Moisture Sensitivity Level	Level 1	IPC/JEDEC J-STD-020



Caution!
ESD-Sensitive Device

Solderability

Compatible with lead-free (260°C max. reflow temp.) soldering process.
Solder profiles available upon request.

Contact plating - NiPdAu (*Thickness: Ni 0.508 ~ 1.524 μm; Pd 0.023 ~ 0.1016 μm; Au 0.00254 ~ 0.01016 μm*)

RoHS Compliance

This part is compliant with 2011/65/EU RoHS directive (Restrictions on the Use of Certain Hazardous Substances in Electrical and Electronic Equipment) as amended by Directive 2015/863/EU.

This product also has the following attributes:

- Lead Free
- Halogen Free (Chlorine, Bromine)
- Antimony Free
- TBBP-A (C₁₅H₁₂Br₄O₂) Free
- SVHC Free



Contact Information

For the latest specifications, additional product information, worldwide sales and distribution locations:

Web: www.qorvo.com

Tel: 1-844-890-8163

Email: customer.support@qorvo.com

Important Notice

The information contained herein is believed to be reliable; however, Qorvo makes no warranties regarding the information contained herein and assumes no responsibility or liability whatsoever for the use of the information contained herein. All information contained herein is subject to change without notice. Customers should obtain and verify the latest relevant information before placing orders for Qorvo products. The information contained herein or any use of such information does not grant, explicitly or implicitly, to any party any patent rights, licenses, or any other intellectual property rights, whether with regard to such information itself or anything described by such information. **THIS INFORMATION DOES NOT CONSTITUTE A WARRANTY WITH RESPECT TO THE PRODUCTS DESCRIBED HEREIN, AND QORVO HEREBY DISCLAIMS ANY AND ALL WARRANTIES WITH RESPECT TO SUCH PRODUCTS WHETHER EXPRESS OR IMPLIED BY LAW, COURSE OF DEALING, COURSE OF PERFORMANCE, USAGE OF TRADE OR OTHERWISE, INCLUDING THE IMPLIED WARRANTIES OF MERCHANTABILITY AND FITNESS FOR A PARTICULAR PURPOSE.**

Without limiting the generality of the foregoing, Qorvo products are not warranted or authorized for use as critical components in medical, life-saving, or life-sustaining applications, or other applications where a failure would reasonably be expected to cause severe personal injury or death.

Copyright 2020 © Qorvo, Inc. | Qorvo is a registered trademark of Qorvo, Inc.

X-ON Electronics

Largest Supplier of Electrical and Electronic Components

Click to view similar products for [RF Amplifier](#) category:

Click to view products by [Qorvo](#) manufacturer:

Other Similar products are found below :

[A82-1](#) [BGA622H6820XTSA1](#) [BGA 728L7 E6327](#) [BGB719N7ESDE6327XTMA1](#) [HMC397-SX](#) [HMC405](#) [HMC561-SX](#) [HMC8120-SX](#)
[HMC8121-SX](#) [HMC-ALH382-SX](#) [HMC-ALH476-SX](#) [SE2433T-R](#) [SMA3101-TL-E](#) [SMA39](#) [A66-1](#) [A66-3](#) [A67-1](#) [LX5535LQ](#) [LX5540LL](#)
[MAAM02350](#) [HMC3653LP3BETR](#) [HMC549MS8GETR](#) [HMC-ALH435-SX](#) [SMA101](#) [SMA32](#) [SMA411](#) [SMA531](#) [SST12LP19E-QX6E](#)
[WPM0510A](#) [HMC5929LS6TR](#) [HMC5879LS7TR](#) [HMC1126](#) [HMC1087F10](#) [HMC1086](#) [HMC1016](#) [SMA1212](#) [MAX2689EWS+T](#)
[MAAMSS0041TR](#) [MAAM37000-A1G](#) [LTC6430AIUF-15#PBF](#) [SMA70-2](#) [SMA4011](#) [A231](#) [HMC-AUH232](#) [LX5511LQ](#) [LX5511LQ-TR](#)
[HMC7441-SX](#) [HMC-ALH310](#) [XD1001-BD-000V](#) [A4011](#)