

Product Overview

The QPQ1270 is a high-performance, Bulk Acoustic Wave (BAW) duplexer designed for Band 7 uplink and downlink applications.

The QPQ1270 provides low insertion loss and high rejection, making it an ideal choice for small cells. This duplexer is housed in a compact RoHS compliant 2.00 mm x 2.50 mm x 1.015 mm surface mount package.

The QPQ1270 is part of Qorvo’s extensive portfolio of RF BAW and SAW filters.



9 Pad 2.00 mm x 2.50 mm x 1.015 mm SMP

Functional Block Diagram

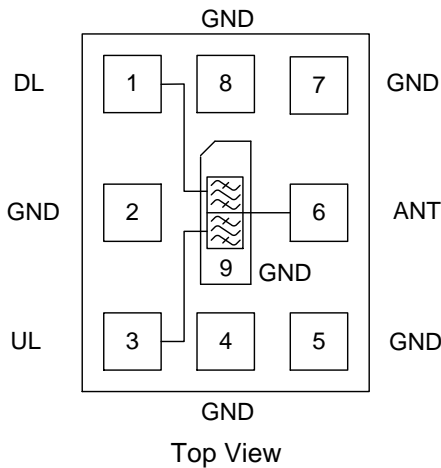

Pin Configuration

Pin No.	Label	Function
1	DL	Downlink Input
2, 4, 5, 7, 8, 9	GND	Ground
3	UL	Uplink Output
6	ANT	Antenna Port

Key Features

- 70 MHz Bandwidth – Band 7 UL/DL
- Low Insertion Loss
- High Out of Band Attenuation
- Small 2.00 mm x 2.50 mm x 1.015 mm Surface Mount Package (SMP)
- Wide Temperature Range with Guaranteed specifications: - 40 °C to + 95 °C
- High Operating Temperature: +105 °C
- High Power Rating: 30 dBm on DL or UL at +95 °C
- No External Matching Required
- RoHS Compliant, Pb-Free



Applications

- Base Stations Infrastructure
- Small Cells
- Repeaters
- LTE Dongles
- General Purpose Wireless

Ordering Information

Part No.	Description
QPQ1270TR7	7" Taped Reel with 2500 pieces
QPQ1270EVB	Assembled Evaluation Board

Absolute Maximum Ratings ⁽¹⁾

Parameter	Rating
Storage Temperature	-40 to +125°C
Operating Temperature ⁽²⁾	-40 to +105°C

Notes:

1. Operation of this device outside the parameter ranges given may cause permanent damage.
2. Device will function but it is not guaranteed to meet electrical specifications

Minimum Lifetime Ratings

Conditions	Rating
+30 dBm at Pin 1 (DL to ANT), 2620-2690 MHz, FD-LTE, 5 MHz, 16 QAM, 25 RB, PAR 8 dB, +95°C	>87,600 hours
+30 dBm at Pin 6 (ANT to UL), 2500-2570 MHz, FD-LTE, 5 MHz, 16 QAM, 25 RB, PAR 8 dB, +95°C	>87,600 hours
+30 dBm at Pin 3 (UL to ANT), 2500-2570 MHz, FD-LTE, 5 MHz, 16 QAM, 25 RB, PAR 8 dB, +95°C	>87,600 hours

Electrical Specifications – Uplink ⁽³⁾

Test conditions unless otherwise noted: Temp = -20°C to +85°C

Parameter	Conditions	Min	Typ ⁽⁷⁾	Max	Units
Center Frequency		–	2535	–	MHz
Average Insertion Loss ⁽⁴⁾	2500 – 2505 MHz (-20°C to +35°C)	–	2.4	3.6	dB
	2500 – 2505 MHz (+35°C to +85°C)	–	2.4	3.3	
	2505 – 2565 MHz	–	1.6	2.0	
	2565 – 2570 MHz	–	2.1	3.2	
Amplitude Variation ⁽⁵⁾	2500 – 2570 MHz	–	1.3	3.0	dB
Group Delay Variation ⁽⁶⁾	2500 – 2570 MHz (over any 5 MHz)	–	4.3	20	ns p-p
Phase Ripple ⁽⁶⁾	2500 – 2570 MHz (over any 5 MHz)	–	1.1	8	° p-p
Return Loss	Antenna Port (2500 – 2570 MHz)	8.3	11.2	–	dB
	Uplink Port (2500 – 2570 MHz)	8.3	11.6	–	
Attenuation ⁽⁸⁾	100 – 700 MHz	30	58	–	dB
	700 – 960 MHz	40	53	–	
	960 – 1805 MHz	30	48	–	
	1805 – 1880 MHz	43	51	–	
	1880 – 2110 MHz	25	52	–	
	2110 – 2170 MHz	45	54	–	
	2170 – 2300 MHz	25	52	–	
	2300 – 2400 MHz	45	51	–	
	2402 – 2474 MHz	40	55	–	
	2474 – 2480 MHz	7	38	–	
	2590 – 2620 MHz	10	18	–	
	2620 – 2690 MHz	54	56	–	
	2690 – 3400 MHz	25	42	–	
	3400 – 3800 MHz	30	42	–	
3800 – 5150 MHz	15	45	–		
5150 – 6000 MHz	25	54	–		
WiFi Attenuation ⁽⁹⁾	2401 – 2473 MHz (WiFi Channel 1 to 11)	48	58	–	dB
Source/Load Impedance ⁽¹⁰⁾	Single-ended	–	50	–	Ω

Notes:

3. All specifications are based on the Qorvo schematic for the main reference design.
4. Average Insertion Loss is calculated by averaging |S21| in dB for each measured point within defined frequency range.
5. Amplitude Variation is defined as the difference between the lowest loss and the highest loss within defined frequency range.
6. This is defined as the worst difference between a peak and adjacent valley within defined frequency range.
7. Typical values are based on average measurements of 12 devices at room temperature.
8. Relative to zero dB.
9. Data is an integrated channel measurement from 2412 MHz to 2462 MHz with a 22 MHz channel width and 5 MHz step size (802.11b).
10. This is the optimum impedance in order to achieve the performance shown.

Electrical Specifications – Downlink ⁽¹⁾

Test conditions unless otherwise noted: Temp = -20 °C to +85 °C

Parameter	Conditions	Min	Typ ⁽⁵⁾	Max	Units
Center Frequency		–	2655	–	MHz
Average Insertion Loss ⁽²⁾	2620 – 2625 MHz	–	2.3	3.0	dB
	2625 – 2685 MHz	–	1.8	2.2	
	2685 – 2690 MHz	–	2.1	3.0	
Amplitude Variation ⁽³⁾	2620 – 2690 MHz	–	1.0	1.8	dB
Group Delay Variation ⁽⁴⁾	2620 – 2690 MHz (over any 5 MHz)	–	4.1	20	ns p-p
Phase Ripple ⁽⁴⁾	2620 – 2690 MHz (over any 5 MHz)	–	1.1	8	° p-p
Return Loss	Antenna Port (2620 – 2690 MHz)	9.1	12.2	–	dB
	Downlink Port (2620 – 2690 MHz)	8.3	10.8	–	
Attenuation ⁽⁶⁾	100 – 960 MHz	35	63	–	dB
	960 – 1710 MHz	30	53	–	
	1710 – 1920 MHz	45	53	–	
	1920 – 1980 MHz	46	52	–	
	1980 – 2300 MHz	30	53	–	
	2300 – 2400 MHz	57	60	–	
	2400 – 2484 MHz	57	60	–	
	2485 – 2570 MHz (5MHz averaging) ⁽⁸⁾	55	60	–	
	2570 – 2585 MHz	25	51	–	
	2585 – 2595 MHz	5	30	–	
	2715 – 2725 MHz	5	25	–	
	2725 – 2800 MHz	25	58	–	
	2800 – 3400 MHz	30	58	–	
	3400 – 3800 MHz	30	52	–	
	3800 – 5150 MHz	20	45	–	
5150 – 5400 MHz	40	62	–		
5400 – 6000 MHz	30	62	–		
2 nd Harmonic at ANT	P _{in} = +27 dBm into DL (2620-2690)	–	67	–	dBc
IMD3L at Uplink	2 Tone of P _{in} = +24 dBm into DL port	–	101	–	dBc
IMD5L at Uplink	2 Tone of P _{in} = +24 dBm into DL port	–	157	–	dBc
Source/Load Impedance ⁽⁷⁾	Single-ended	–	50	–	Ω

Electrical Specifications – Isolation ⁽¹⁾

Test conditions unless otherwise specified: Temp = -20 °C to +85 °C

Parameter	Conditions ^(1, 2)	Min	Typ ⁽⁵⁾	Max	Unit
Isolation ⁽⁸⁾	2500 – 2560 MHz	57	61	–	dB
	2560 – 2570 MHz	54	59	–	
	2620 – 2690 MHz	57	59	–	

Notes:

- All specifications are based on the Qorvo schematic for the main reference design.
- Average Insertion Loss is calculated by averaging |S₂₁| in dB for each measured point within defined frequency range.
- Amplitude Variation is defined as the difference between the lowest loss and the highest loss within defined frequency range.
- This is defined as the worst difference between a peak and adjacent valley within defined frequency range.
- Typical values are based on average measurements of 12 devices at room temperature.
- Relative to zero dB.
- This is the optimum impedance in order to achieve the performance shown.
- Data is the integrated loss value with respect to zero dB of the linear s-parameter over 5MHz range.

Electrical Specifications – Uplink ⁽¹⁾

Test conditions unless otherwise noted: Temp = -40 °C to +95 °C

Parameter	Conditions	Min	Typ ⁽⁵⁾	Max	Units
Center Frequency		–	2535	–	MHz
Average Insertion Loss ⁽²⁾	2500 – 2505 MHz (-40 °C to +35 °C)	–	2.4	3.8	dB
	2500 – 2505 MHz (+35 °C to +95 °C)	–	2.4	3.3	
	2505 – 2565 MHz	–	1.6	2.2	
	2565 – 2570 MHz	–	2.1	3.4	
Amplitude Variation ⁽³⁾	2500 – 2570 MHz	–	1.3	3.2	dB
Group Delay Variation ⁽⁴⁾	2500 – 2570 MHz (over any 5 MHz)	–	4.3	22	ns p-p
Phase Ripple ⁽⁴⁾	2500 – 2570 MHz (over any 5 MHz)	–	1.1	9	° p-p
Return Loss	Antenna Port (2500 – 2570 MHz)	8.3	11.2	–	dB
	Uplink Port (2500 – 2570 MHz)	8.3	11.6	–	
Attenuation ⁽⁶⁾	100 – 700 MHz	30	58	–	dB
	700 – 960 MHz	40	53	–	
	960 – 1805 MHz	30	48	–	
	1805 – 1880 MHz	43	51	–	
	1880 – 2110 MHz	25	52	–	
	2110 – 2170 MHz	45	54	–	
	2170 – 2300 MHz	25	51	–	
	2300 – 2400 MHz	45	51	–	
	2402 – 2474 MHz	38	55	–	
	2474 – 2480 MHz	5	38	–	
	2590 – 2620 MHz	9	18	–	
	2620 – 2690 MHz	53	56	–	
	2690 – 3400 MHz	25	42	–	
	3400 – 3800 MHz	30	42	–	
3800 – 5150 MHz	15	45	–		
5150 – 6000 MHz	25	54	–		
WiFi Attenuation ⁽⁷⁾	2401 – 2473 MHz (WiFi Channel 1 to 11)	47	58	–	dB
Source/Load Impedance ⁽⁸⁾	Single-ended	–	50	–	Ω

Notes:

1. All specifications are based on the Qorvo schematic for the main reference design.
2. Average Insertion Loss is calculated by averaging |S21| in dB for each measured point within defined frequency range.
3. Amplitude Variation is defined as the difference between the lowest loss and the highest loss within defined frequency range.
4. This is defined as the worst difference between a peak and adjacent valley within defined frequency range.
5. Typical values are based on average measurements of 12 devices at room temperature.
6. Relative to zero dB.
7. Data is an integrated channel measurement from 2412 MHz to 2462 MHz with a 22 MHz channel width and 5 MHz step size (802.11b).
8. This is the optimum impedance in order to achieve the performance shown.

Electrical Specifications – Downlink ⁽¹⁾

Test conditions unless otherwise noted: Temp = -40 °C to +95 °C

Parameter	Conditions	Min	Typ ⁽⁵⁾	Max	Units
Center Frequency		–	2655	–	MHz
Average Insertion Loss ⁽²⁾	2620 – 2625 MHz	–	2.3	3.0	dB
	2620 – 2665 MHz	–	1.8	2.3	
	2665 – 2690 MHz	–	2.1	3.2	
Amplitude Variation ⁽³⁾	2620 – 2690 MHz	–	0.8	2.0	dB
Group Delay Variation ⁽⁴⁾	2620 – 2690 MHz (over any 5 MHz)	–	4.1	21	ns p-p
Phase Ripple ⁽⁴⁾	2620 – 2690 MHz (over any 5 MHz)	–	1.1	9	° p-p
Return Loss	Antenna Port (2620 – 2690 MHz)	9.0	12.2	–	dB
	Uplink Port (2620 – 2690 MHz)	8.3	12.1	–	
Attenuation ⁽⁶⁾	100 – 960 MHz	35	63	–	dB
	960 – 1710 MHz	30	53	–	
	1710 – 1920 MHz	45	53	–	
	1920 – 1980 MHz	46	52	–	
	1980 – 2300 MHz	30	53	–	
	2300 – 2400 MHz	56	60	–	
	2400 – 2484 MHz	56	60	–	
	2485 – 2570 MHz (5MHz averaging) ⁽⁸⁾	54	60	–	
	2570 – 2585 MHz	24	51	–	
	2585 – 2595 MHz	4	30	–	
	2715 – 2725 MHz	4	25	–	
	2725 – 2800 MHz	24	58	–	
	2800 – 3400 MHz	30	58	–	
	3400 – 3800 MHz	30	52	–	
	3800 – 5150 MHz	20	45	–	
5150 – 5400 MHz	40	62	–		
5400 – 6000 MHz	30	62	–		
2 nd Harmonic at ANT	P _{in} = +27 dBm into DL (2620-2690)	–	67	–	dBc
IMD3L at Uplink	2 Tone of Pin = +23 dBm into DL port	–	101	–	dBc
IMD5L at Uplink	2 Tone of Pin = +23 dBm into DL port	–	157	–	dBc
Source/Load Impedance ⁽⁷⁾	Single-ended	–	50	–	Ω

Electrical Specifications – Isolation ⁽¹⁾

Test conditions unless otherwise specified: Temp = -40 °C to +95 °C

Parameter	Conditions ^(1, 2)	Min	Typ ⁽⁵⁾	Max	Unit
Isolation ⁽⁸⁾	2500 – 2560 MHz	56	61	–	dB
	2560 – 2570 MHz	53	59	–	
	2620 – 2690 MHz	56	59	–	

Notes:

- All specifications are based on the Qorvo schematic for the main reference design.
- Average Insertion Loss is calculated by averaging |S₂₁| in dB for each measured point within defined frequency range.
- Amplitude Variation is defined as the difference between the lowest loss and the highest loss within defined frequency range.
- This is defined as the worst difference between a peak and adjacent valley within defined frequency range.
- Typical values are based on average measurements of 12 devices at room temperature.
- Relative to zero dB.
- This is the optimum impedance in order to achieve the performance shown.
- Data is the integrated loss value with respect to zero dB of the linear s-parameter over 5MHz range.

Evaluation Board and Schematic – QPQ1270EVB

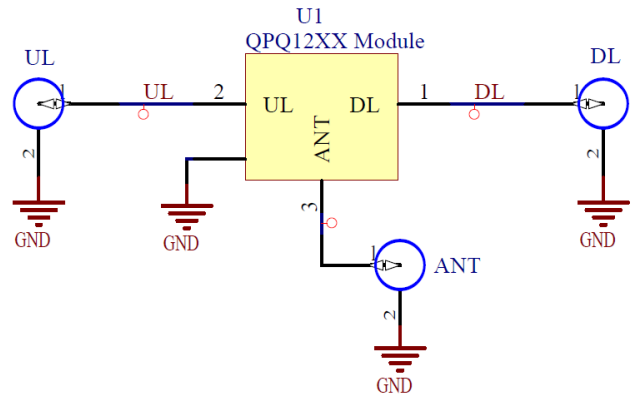

Bill of Material – QPQ1270EVB

Ref. Des.	Value	Description	Manufacturer	Part Number
U1	–	Duplexer, Band7, BAW	Qorvo	QPQ1270
SMA	–	Connector, SMA	Radiall	9602-1111-018
PCB	–	Printed Circuit Board, Evaluation	Qorvo	283666

De-embedded Performance Plots Uplink

Test conditions unless otherwise noted: Temp= +25°C

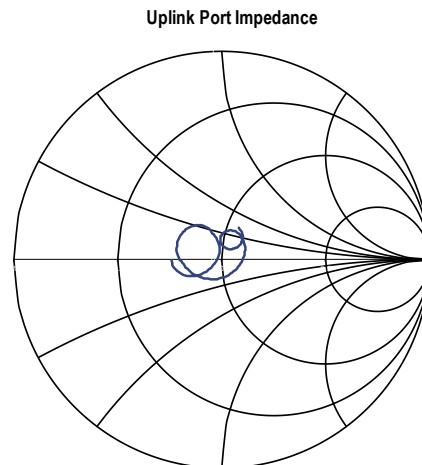
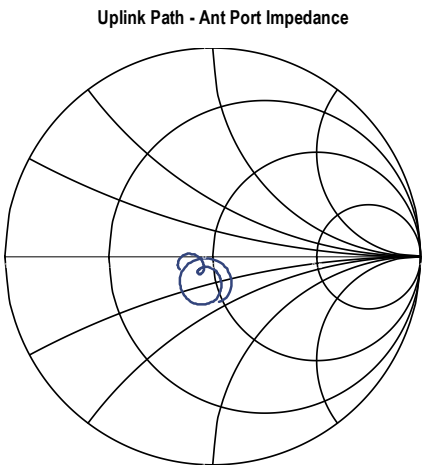
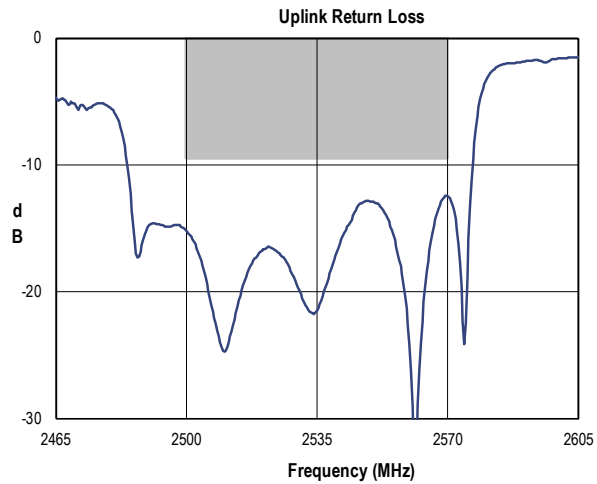
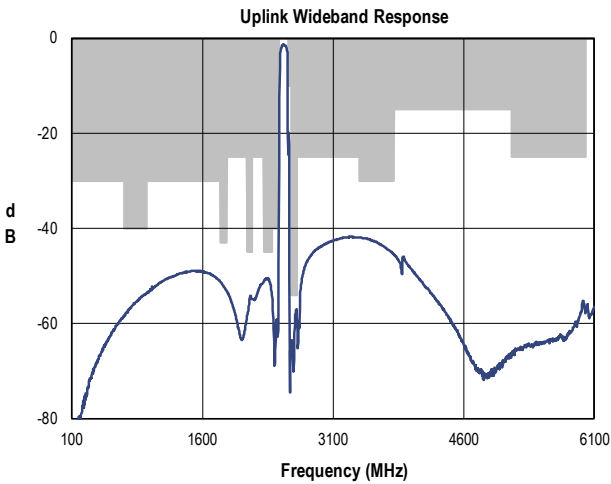
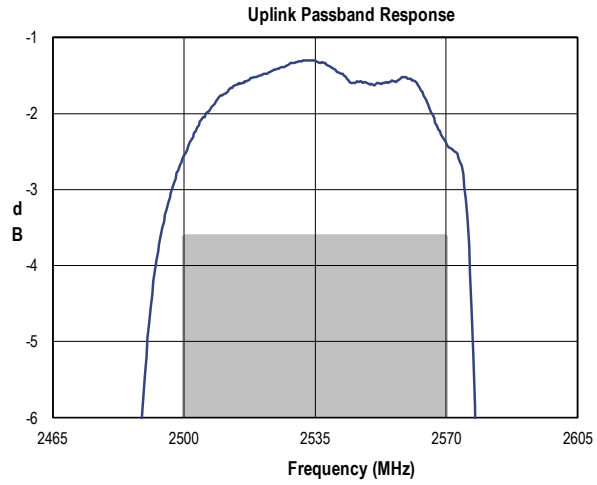
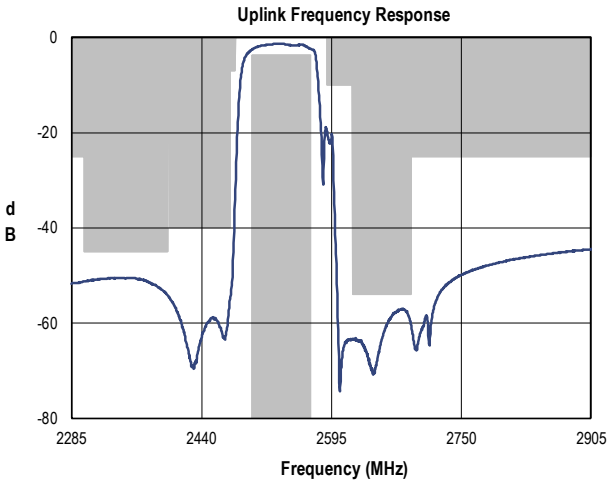

De-embedded Performance Plots Downlink

Test conditions unless otherwise noted: Temp= +25°C

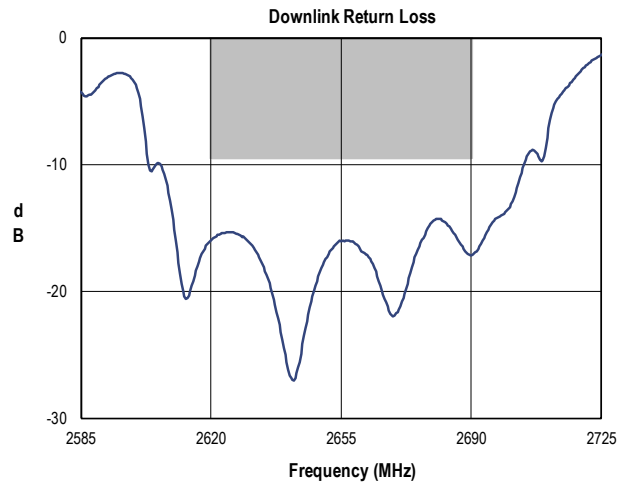
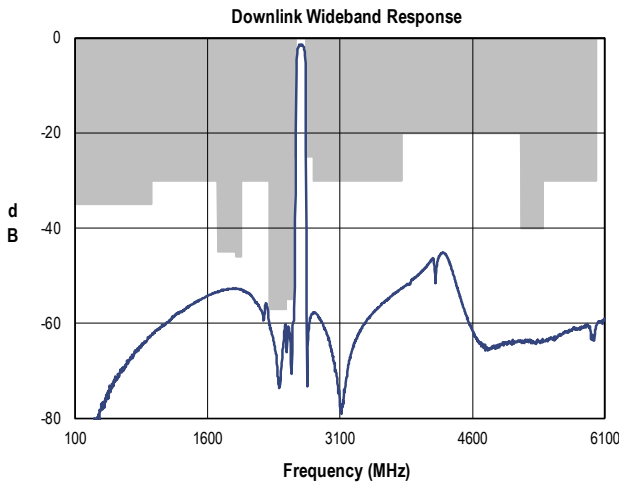
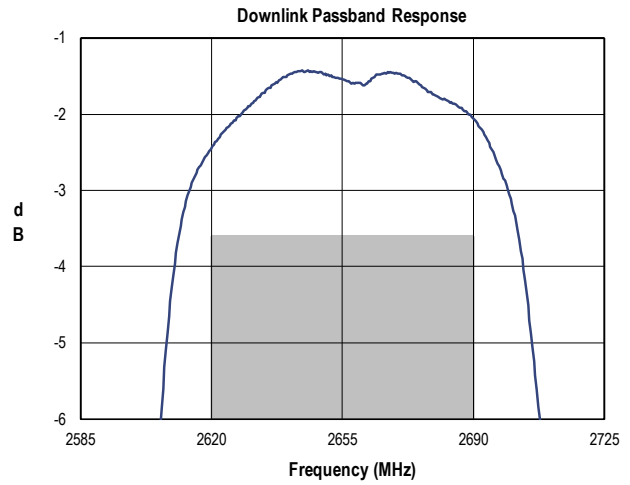
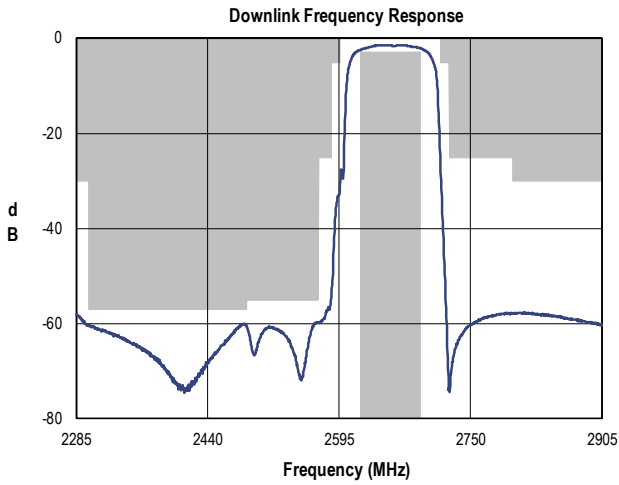

Downlink Path - Ant Port Impedance

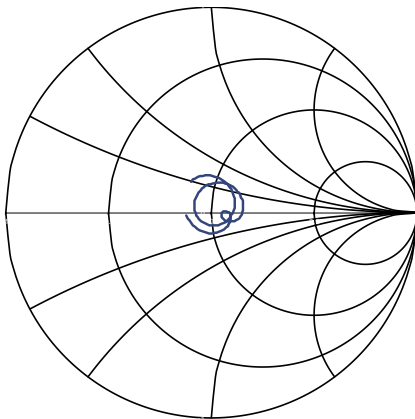

Downlink Port Impedance

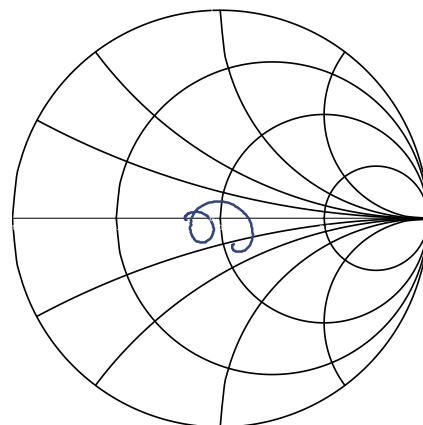

De-embedded Performance Plots Isolation

Test conditions unless otherwise noted: Temp= +25°C

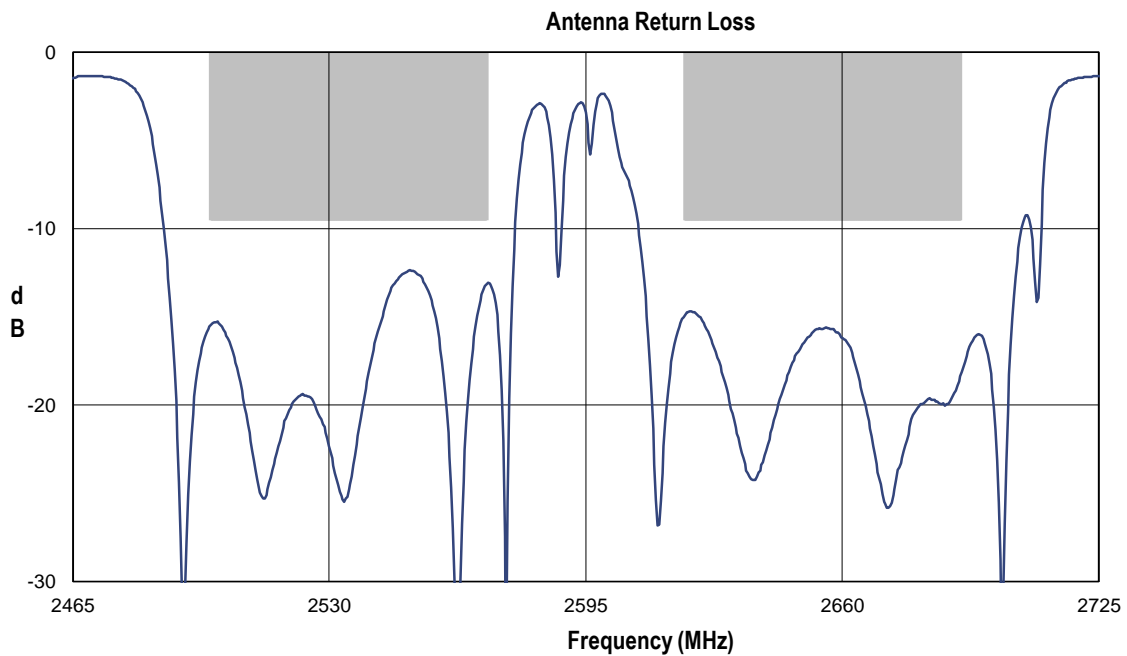
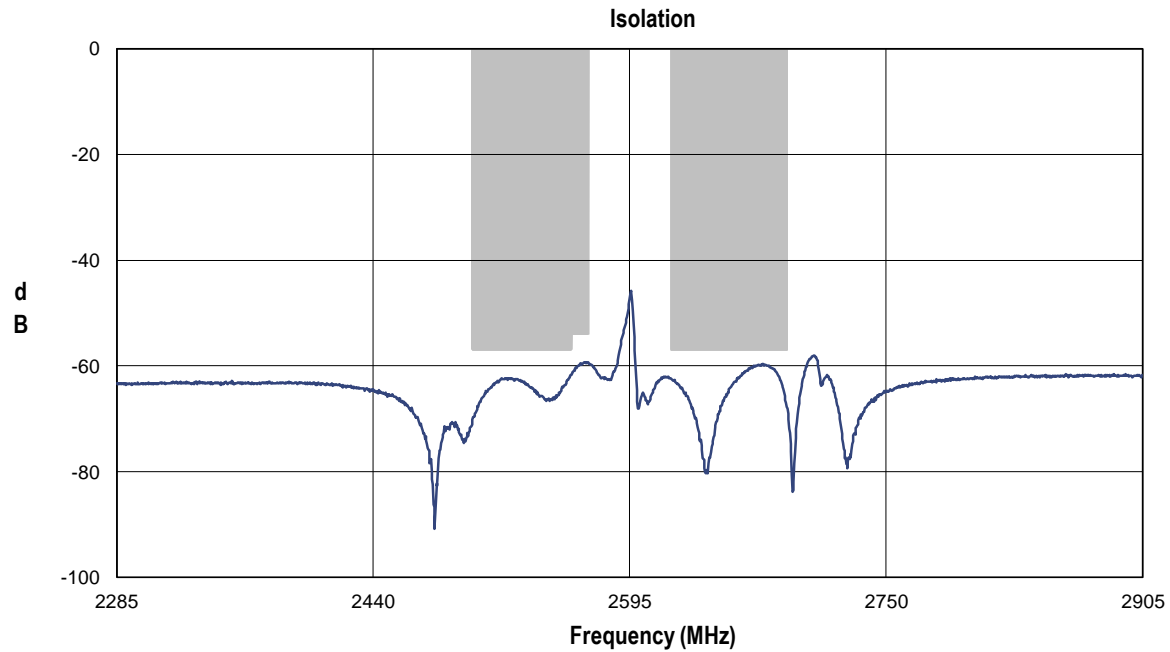

Package Dimensions

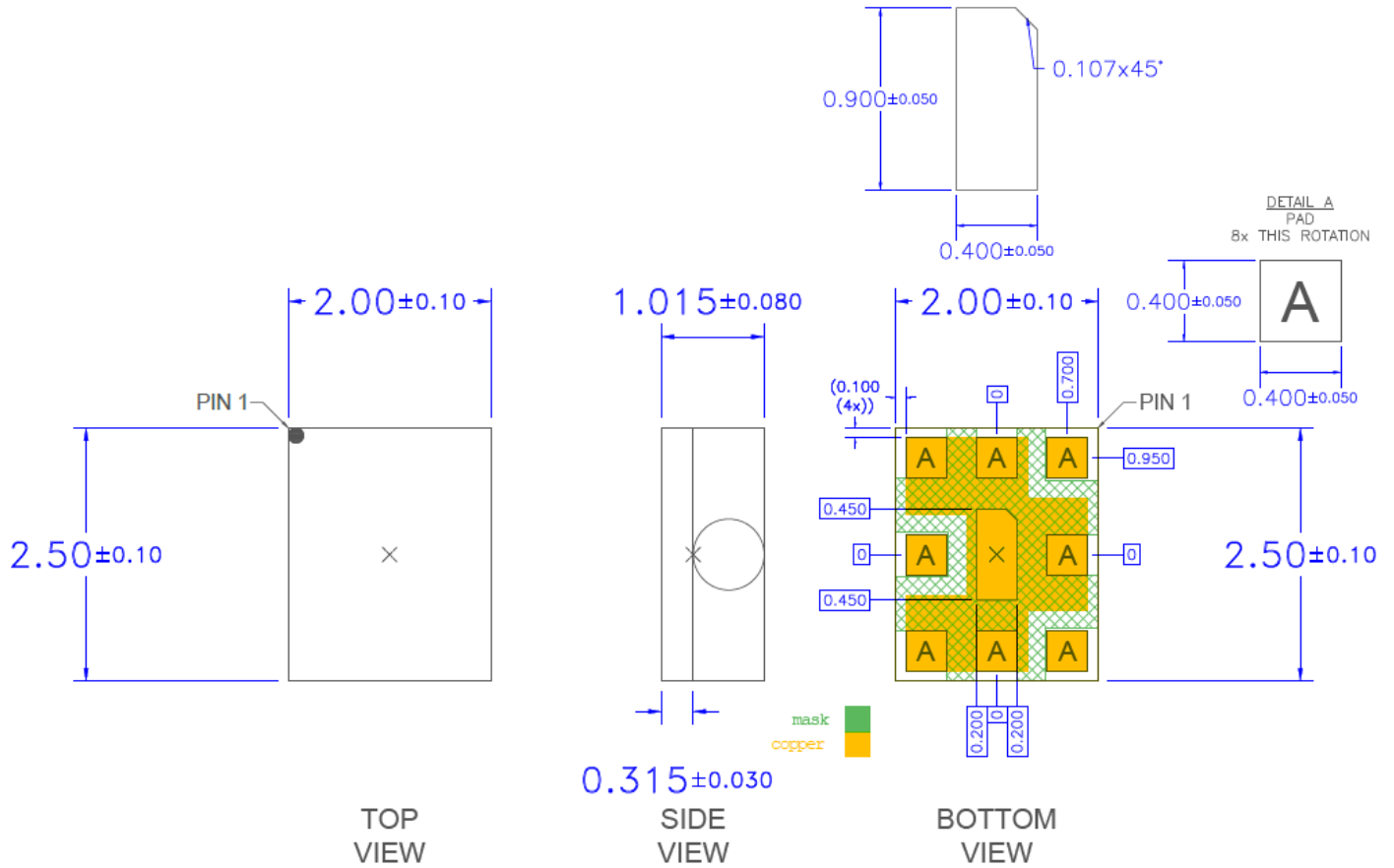

Notes:

1. All dimensions are in millimeters. Angles are in degrees.
2. Dimension and tolerance formats conform to ASME Y14.4M-1994.
3. The terminal #1 identifier and terminal numbering conform to JESD 95-1 SPP-012.

Package Marking

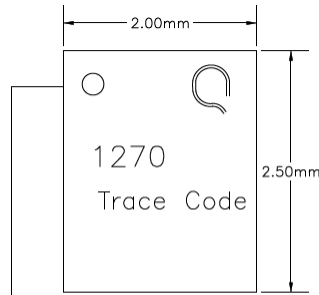

Line 1: Pin 1 dot + logo use Q5D
 Line 2: Part number
 Line 3: 4-digit Short trace code.

PCB Mounting Pattern

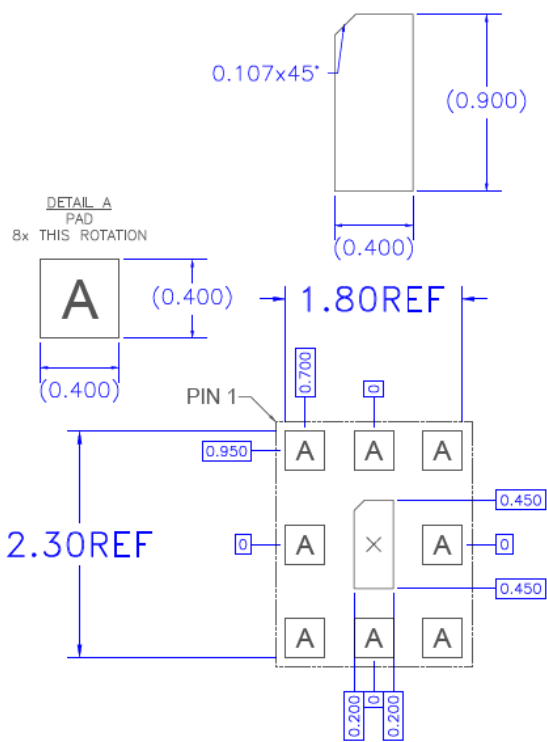

RECOMMENDED
LAND PATTERN

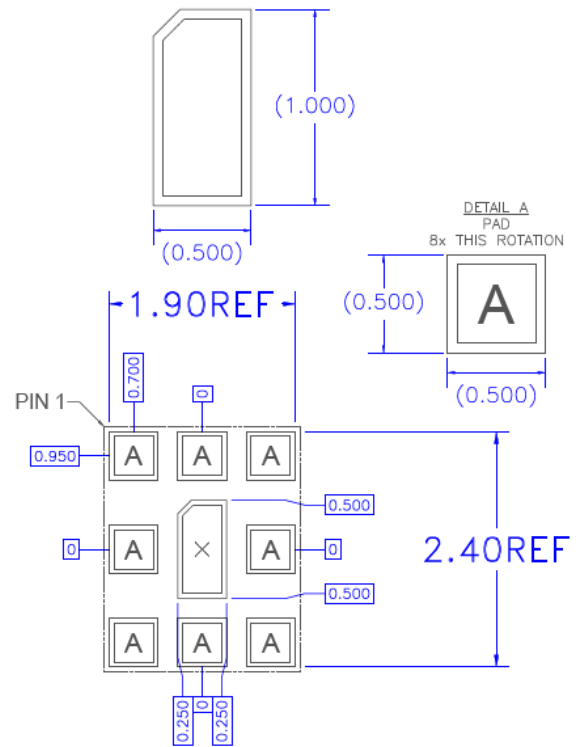

RECOMMENDED
LAND PATTERN MASK

Notes:

1. All dimensions are in millimeters. Angles are in degrees.
2. This drawing specifies the mounting pattern used on the Qorvo evaluation board for this product. Some modification may be necessary to suit end user assembly materials and processes.

Tape and Reel Information – Carrier and Cover Tape Dimensions

Tape and reel specifications for this part are also available on the Qorvo website.
Standard T/R size = 2500 pieces on a 7" reel.

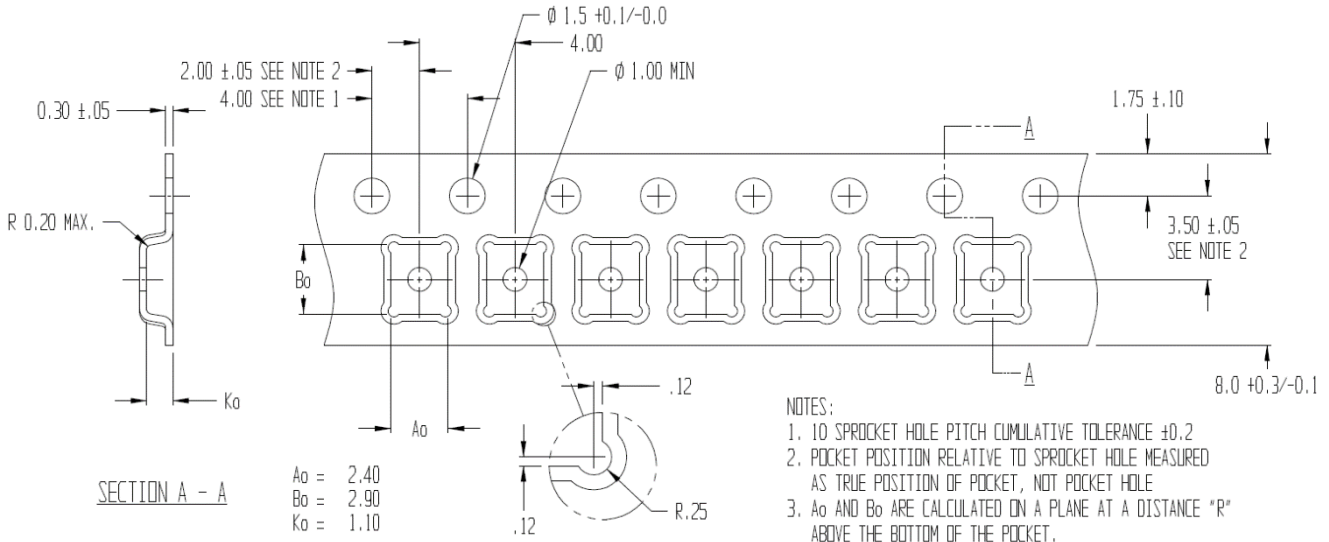

Feature	Measure	Symbol	Size (in)	Size (mm)
Cavity	Length	A0	0.094	2.40
	Width	B0	0.114	2.90
	Depth	K0	0.043	1.10
	Pitch	P1	0.157	4.00
Centerline Distance	Cavity to Perforation - Length Direction	P2	0.079	2.00
	Cavity to Perforation - Width Direction	F	0.138	3.50
Cover Tape	Width	C	0.213	5.40
Carrier Tape	Width	W	0.315	8.00

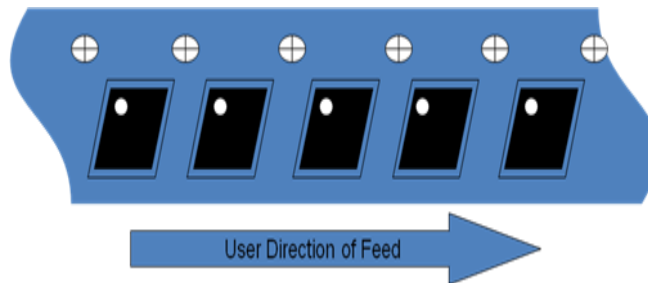

Tape and Reel Information – Reel Dimensions

Tape and reel specifications for this part are also available on the Qorvo website.

Standard T/R size = 2500 pieces on a 7" reel.

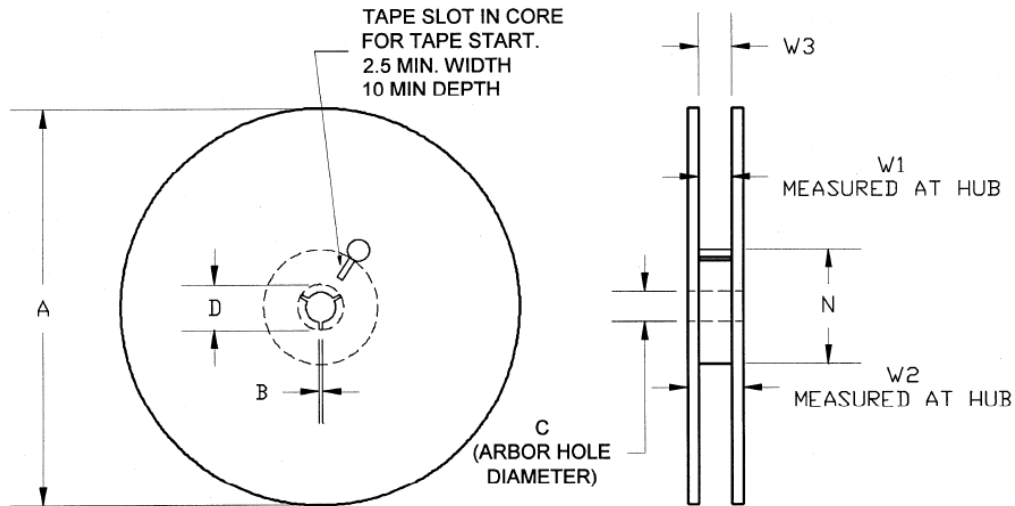

Feature	Measure	Symbol	Size (in)	Size (mm)
Flange	Diameter	A	6.969	177.0
	Thickness	W2	0.559	14.2
	Space Between Flange	W1	0.346	8.8
Hub	Outer Diameter	N	2.283	58.0
	Arbor Hole Diameter	C	0.512	13.0
	Key Slit Width	B	0.079	2.0
	Key Slit Diameter	D	0.787	20.0

Assembly Notes

Compatible with both lead-free (260°C peak reflow temperature) and tin/lead (245°C peak reflow temperature) soldering processes.

Contact Plating: NiAu (*Thickness: Ni 5.0±3.0 μm; Au 0.1 μm min.*)

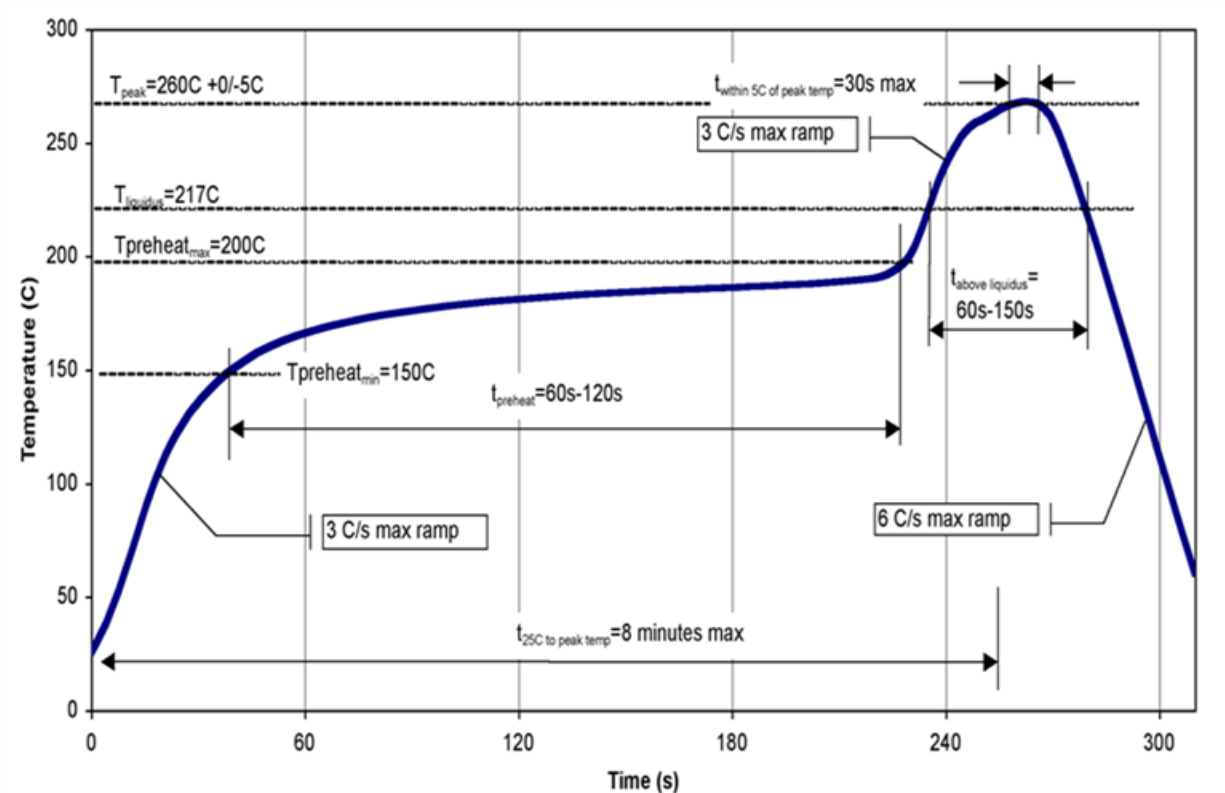

Recommended Soldering Temperature Profile

Handling Precautions

Parameter	Rating	Standard
ESD – Human Body Model (HBM)	Class 1B	ESDA / JEDEC JS-001-2012
ESD – Charged Device Model (CDM)	Class C2b	ESDA / JEDEC JS-002-2014
MSL – Moisture Sensitivity Level	Level 3	IPC/JEDEC J-STD-020



Caution!
ESD-Sensitive Device

RoHS Compliance

This part is compliant with 2011/65/EU RoHS directive (Restrictions on the Use of Certain Hazardous Substances in Electrical and Electronic Equipment) as amended by Directive 2015/863/EU.

This product also has the following attributes:

- Lead Free
- Halogen Free (Chlorine, Bromine)
- Antimony Free
- TBBP-A (C₁₅H₁₂Br₄O₂) Free
- PFOS Free
- SVHC Free



Contact Information

For the latest specifications, additional product information, worldwide sales and distribution locations:

Web: www.qorvo.com

Tel: 1-844-890-8163

Email: customer.support@qorvo.com

Important Notice

The information contained herein is believed to be reliable; however, Qorvo makes no warranties regarding the information contained herein and assumes no responsibility or liability whatsoever for the use of the information contained herein. All information contained herein is subject to change without notice. Customers should obtain and verify the latest relevant information before placing orders for Qorvo products. The information contained herein or any use of such information does not grant, explicitly or implicitly, to any party any patent rights, licenses, or any other intellectual property rights, whether with regard to such information itself or anything described by such information. **THIS INFORMATION DOES NOT CONSTITUTE A WARRANTY WITH RESPECT TO THE PRODUCTS DESCRIBED HEREIN, AND QORVO HEREBY DISCLAIMS ANY AND ALL WARRANTIES WITH RESPECT TO SUCH PRODUCTS WHETHER EXPRESS OR IMPLIED BY LAW, COURSE OF DEALING, COURSE OF PERFORMANCE, USAGE OF TRADE OR OTHERWISE, INCLUDING THE IMPLIED WARRANTIES OF MERCHANTABILITY AND FITNESS FOR A PARTICULAR PURPOSE.**

Without limiting the generality of the foregoing, Qorvo products are not warranted or authorized for use as critical components in medical, life-saving, or life-sustaining applications, or other applications where a failure would reasonably be expected to cause severe personal injury or death.

Copyright 2019 © Qorvo, Inc. | Qorvo is a registered trademark of Qorvo, Inc.

X-ON Electronics

Largest Supplier of Electrical and Electronic Components

Click to view similar products for [RF Development Tools](#) category:

Click to view products by [Qorvo](#) manufacturer:

Other Similar products are found below :

[MAAM-011117](#) [MAAP-015036-DIEEV2](#) [EV1HMC1113LP5](#) [EV1HMC6146BLC5A](#) [EV1HMC637ALP5](#) [EVAL-ADG919EBZ](#) [ADL5363-EVALZ](#) [LMV228SDEVAL](#) [SKYA21001-EVB](#) [SMP1331-085-EVB](#) [EV1HMC618ALP3](#) [EVAL01-HMC1041LC4](#) [MAAL-011111-000SMB](#) [MAAM-009633-001SMB](#) [MASW-000936-001SMB](#) [107712-HMC369LP3](#) [107780-HMC322ALP4](#) [SP000416870](#) [EV1HMC470ALP3](#) [EV1HMC520ALC4](#) [EV1HMC244AG16](#) [MAX2614EVKIT#](#) [124694-HMC742ALP5](#) [SC20ASATEA-8GB-STD](#) [MAX2837EVKIT+](#) [MAX2612EVKIT#](#) [MAX2692EVKIT#](#) [EV1HMC629ALP4E](#) [SKY12343-364LF-EVB](#) [108703-HMC452QS16G](#) [EV1HMC863ALC4](#) [EV1HMC427ALP3E](#) [119197-HMC658LP2](#) [EV1HMC647ALP6](#) [ADL5725-EVALZ](#) [MAX2371EVKIT#](#) [106815-HMC441LM1](#) [EV1HMC1018ALP4](#) [UXN14M9PE](#) [MAX2016EVKIT](#) [EV1HMC939ALP4](#) [MAX2410EVKIT](#) [MAX2204EVKIT+](#) [EV1HMC8073LP3D](#) [SIMSA868-DKL](#) [SIMSA868C-DKL](#) [SKY65806-636EK1](#) [SKY68020-11EK1](#) [SKY67159-396EK1](#) [SKY66181-11-EK1](#)