

Product Overview

The QPQ1289 is a high-performance Bulk Acoustic Wave (BAW) Duplexer designed for Small Cell applications. It is specifically designed to address bands 4, 10, and 66. For band 66, the uplink is fully covered while the downlink is partially covered with 70 MHz bandwidth.

The QPQ1289 provides low insertion loss and high rejection making it an ideal choice for Small Cells. This duplexer is housed in a compact, RoHS compliant 2.00 mm x 2.50 mm x 0.91 mm surface mount package (SMP).

The QPQ1289 is part of Qorvo's extensive portfolio of RF BAW and SAW filters.



9 Pad 2.00 mm x 2.50 mm x 0.91 mm SMP

Functional Block Diagram

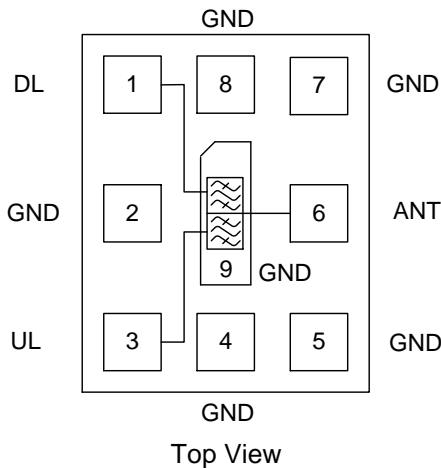

Pin Configuration - Single Ended

Pin No.	Label
1	DL - Downlink port
2, 4, 5, 7, 8, 9	GND - Ground
3	UL - Uplink port
6	ANT - Antenna port

Key Features

- 70 MHz Bandwidth
- High Attenuation
- Low Loss
- Excellent Wi-Fi Rejection
- Single Input, Single Output Operation
- Small Size: 2.00 x 2.50 x 0.91 mm
- Surface Mount Device

Performance is typical across frequency. Please reference electrical specification table and data plots for more details.

Applications

- Extended Band 4 / 10
- Partial Band 66
- Base Station Infrastructure
- General Purpose Wireless

Ordering Information

Part No.	Description
QPQ1289SR	Sample Reel with 100 pieces
QPQ1289TR7	7" Taped Reel with 2500 pieces
QPQ1289EVB	Assembled Evaluation Board

Absolute Maximum Ratings ⁽¹⁾

Parameter	Rating
Storage Temperature	-55 to +125°C
Operating Temperature ⁽²⁾	-40 to +95 °C
RF Input at DL, +25°C Pulse Width 200 ms, Duty Cycle 2%	+39.5 dBm

Notes:

1. Operation of this device outside the parameter ranges given may cause permanent damage.
2. Device will function but it is not guaranteed to meet electrical specifications

Minimum Lifetime Ratings

Conditions	Rating
+29 dBm DL, +85°C, FD-LTE, 5 MHz, 16QAM, PAR=8 dB	>290,000 hours
+23 dBm CW, UL, +85°C	>270,000 hours

Electrical Specifications – Downlink

Test conditions unless otherwise specified. Temperature Range: -40 to +95 °C

Parameter	Conditions ⁽¹⁾	Min	Typ	Max	Unit
Insertion Loss ⁽²⁾	2110 – 2180 MHz	-	2.0	2.9	dB
	2110 – 2170 MHz, B10DL	-	2.0	-	dB
	2110 – 2155 MHz, B4DL	-	2.0	-	dB
Input / Output Return Loss	2110 – 2180 MHz	9	12	-	dB
Amplitude Variation ⁽³⁾	2110 – 2180 MHz	-	0.6	1.0	dB
Attenuation ⁽⁴⁾	10 – 1680 MHz	32	35	-	dB
	1680 – 1800 MHz	42	45	-	dB
	2402 – 2494 MHz	38	43	-	dB
	2496 – 2690 MHz	31	38	-	dB

Electrical Specifications – Uplink

Test conditions unless otherwise specified. Temperature Range: -40°C to +95°C

Parameter	Conditions ⁽¹⁾	Min	Typ.	Max	Unit
Insertion Loss ⁽²⁾	1710 – 1780 MHz	-	2.3	3.2	dB
	1710 – 1770 MHz, B10UL	-	2.3	-	dB
	1710 – 1755 MHz, B4UL	-	2.3	-	dB
Input / Output Return Loss	1710 – 1780 MHz	9	11	-	dB
Amplitude Variation ⁽³⁾	1710 – 1780 MHz	-	0.7	1.5	dB
Attenuation ⁽⁴⁾	10 – 870 MHz	40	45	-	dB
	870 – 1680 MHz	25	32	-	dB
	1850 – 2050 MHz	38	45	-	dB
	2080 – 2225 MHz	32	35	-	dB
	2402 – 2494 MHz	34	37	-	dB
	2496 – 2690 MHz	18	34	-	dB

Notes:

1. All specifications are based on the QORVO schematic for the main reference design.
2. Maximum Insertion Loss within defined frequency range.
3. Amplitude Variation is defined as the difference between the lowest loss and the highest loss within 10 MHz channels.
4. Attenuation is referenced to zero dB

Electrical Specifications – Isolation

Test conditions unless otherwise specified. Temperature Range: -40°C to +95°C

Parameter	Conditions ⁽¹⁾	Min	Typ.	Max	Unit
Isolation	1710 – 1780 MHz	42	45	-	dB
	2110 – 2180 MHz	38	42	-	dB
	1710 – 1780 MHz, B10UL	-	45	-	dB
	2110 – 2170 MHz, B10DL	-	42	-	dB
	1710 – 1755 MHz, B4UL	-	46	-	dB
	2110 – 2155 MHz, B4DL	40	44	-	dB

Notes:

- All specifications are based on the QORVO schematic for the main reference design.

Evaluation Board and Schematic – QPQ1289EVB

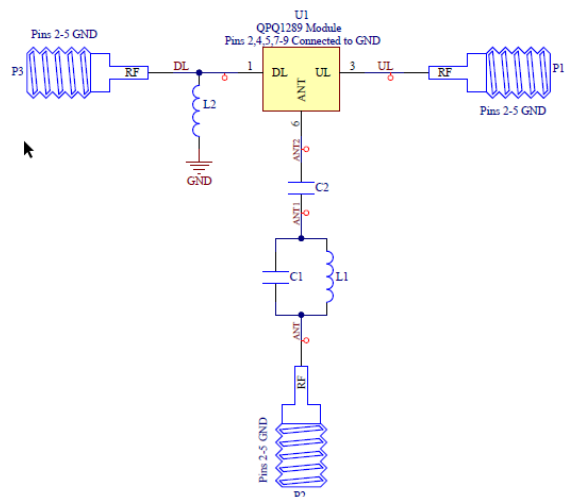
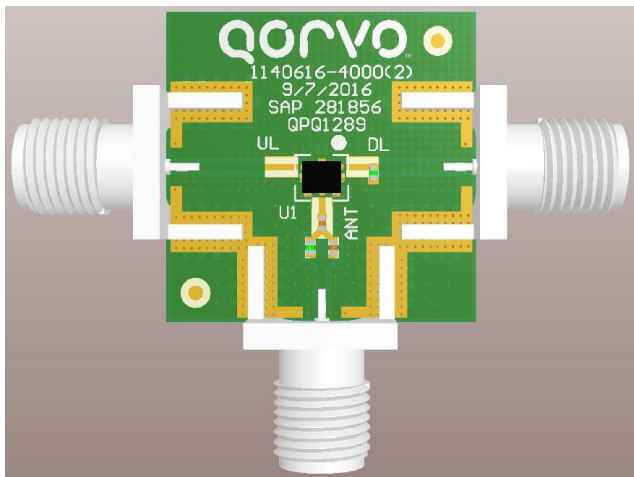

Notes:

- Distance from left side of L2 to right side of U1: 5 mils

Bill of Material – QPQ1289EVB

Ref. Des.	Value	Description	Manufacturer	Part Number
U1	-	Band 66 BAW Duplexer	Qorvo	QPQ1289
-	-	Printed Circuit Board	Qorvo	1140616
C2	3.3 pF	Cap., Chip, 0402, 5%, 50V. NPO/COG	Murata	GJM1555C1H3R3BB01
C1	0.4 pF	Cap., Chip, 0402, +/-0.1pF, 50V. NPO/COG	Murata	GJM1555C1HR40WB01
L2	5.6 nH	Inductor, 0402, LQG	Murata	LQP03TN5N6H02
L1	1.8 nH	Inductor, 0402, LQG	Murata	LQP03TN1N8B02
P1, P2, P3	-	SMA Edge Connector	Radial	9602-1111-018

Performance Plots Uplink

Test conditions unless otherwise noted: Temp= +25°C

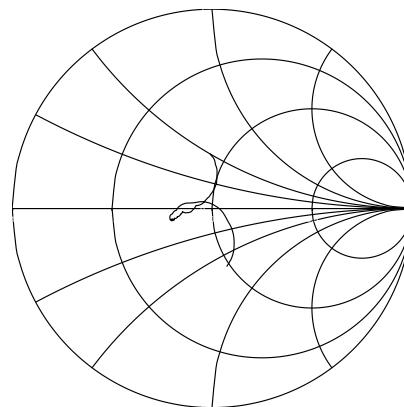
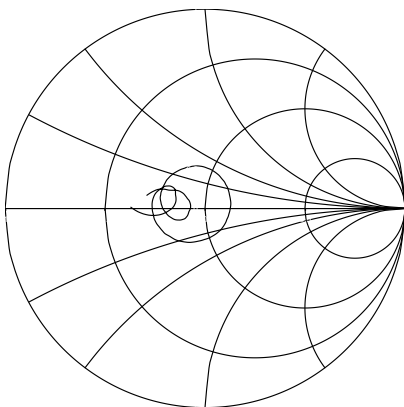
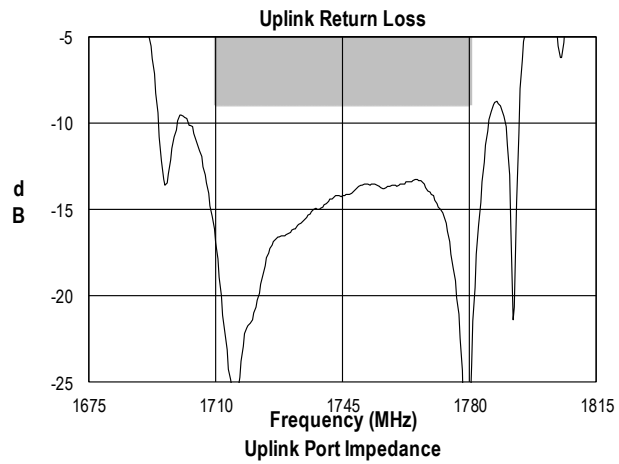
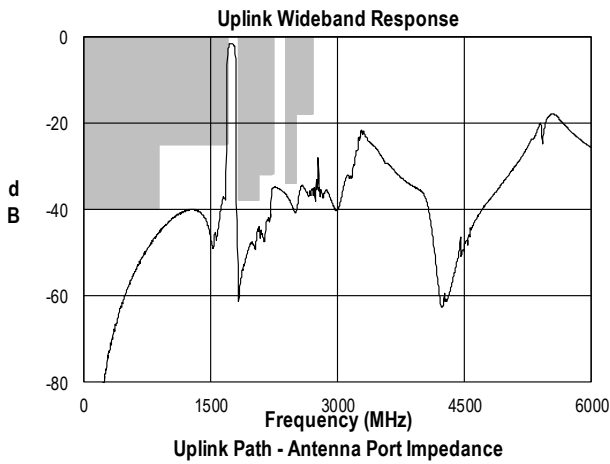
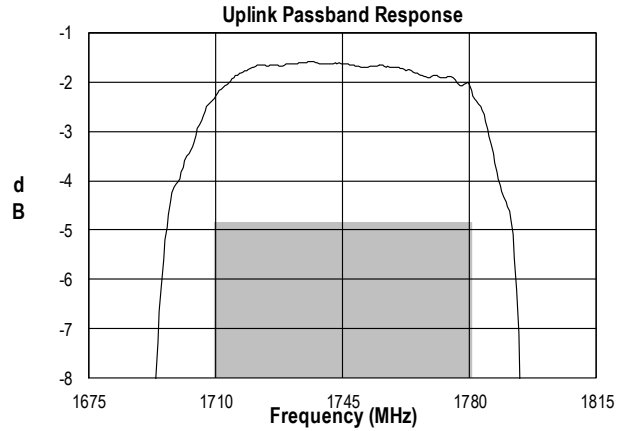
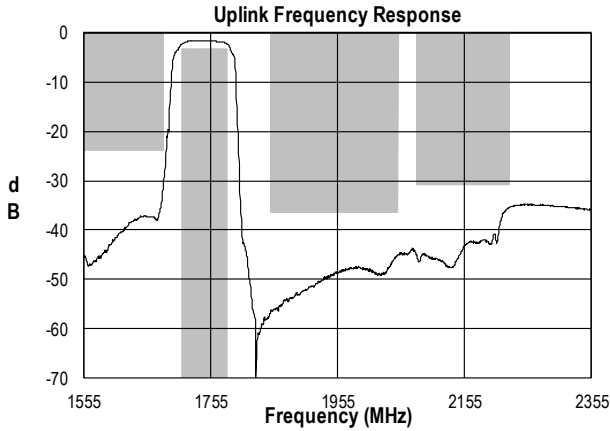

Performance Plots Downlink

Test conditions unless otherwise noted: Temp= +25°C

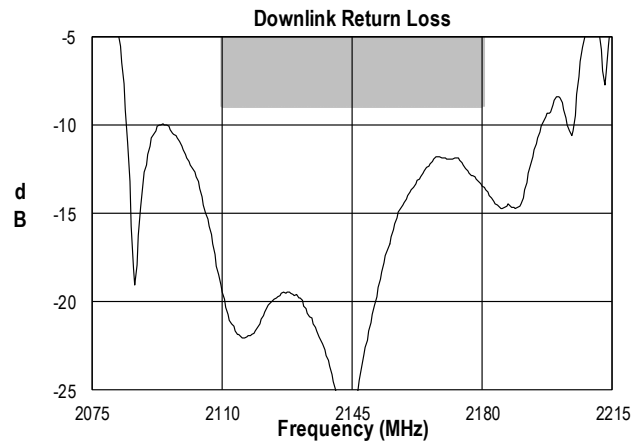
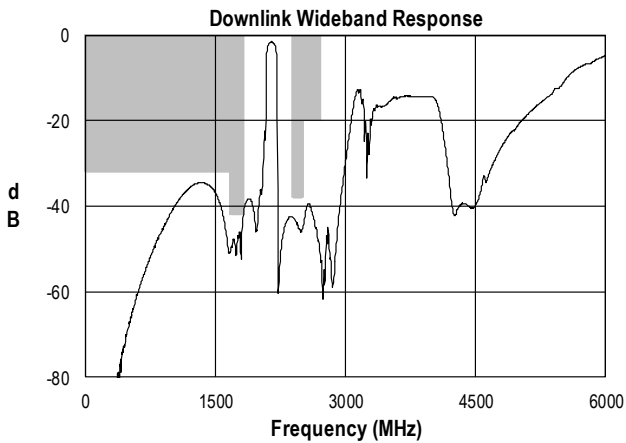
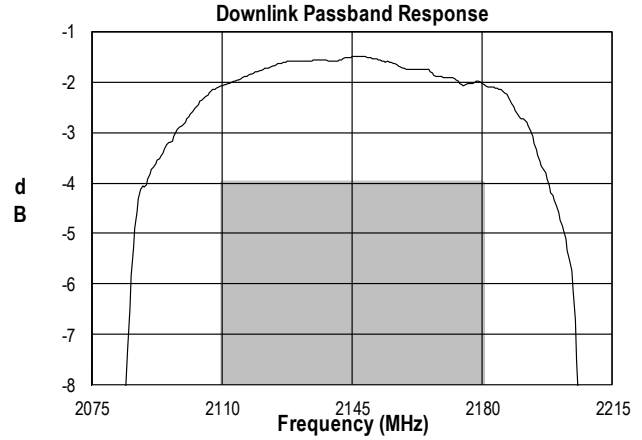
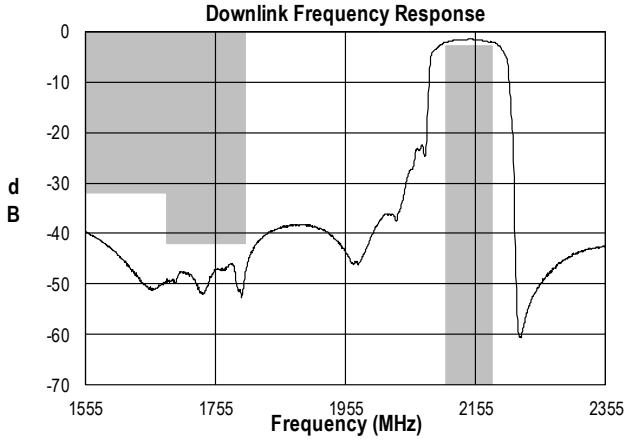

Downlink Path - Antenna Port Impedance

Downlink Port Impedance

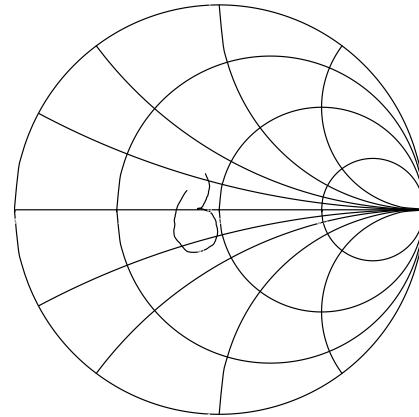
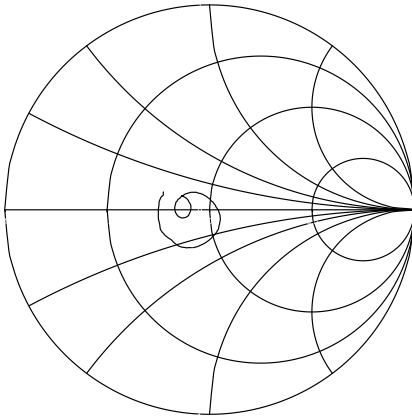

Performance Plots Isolation

Test conditions unless otherwise noted: Temp= +25°C

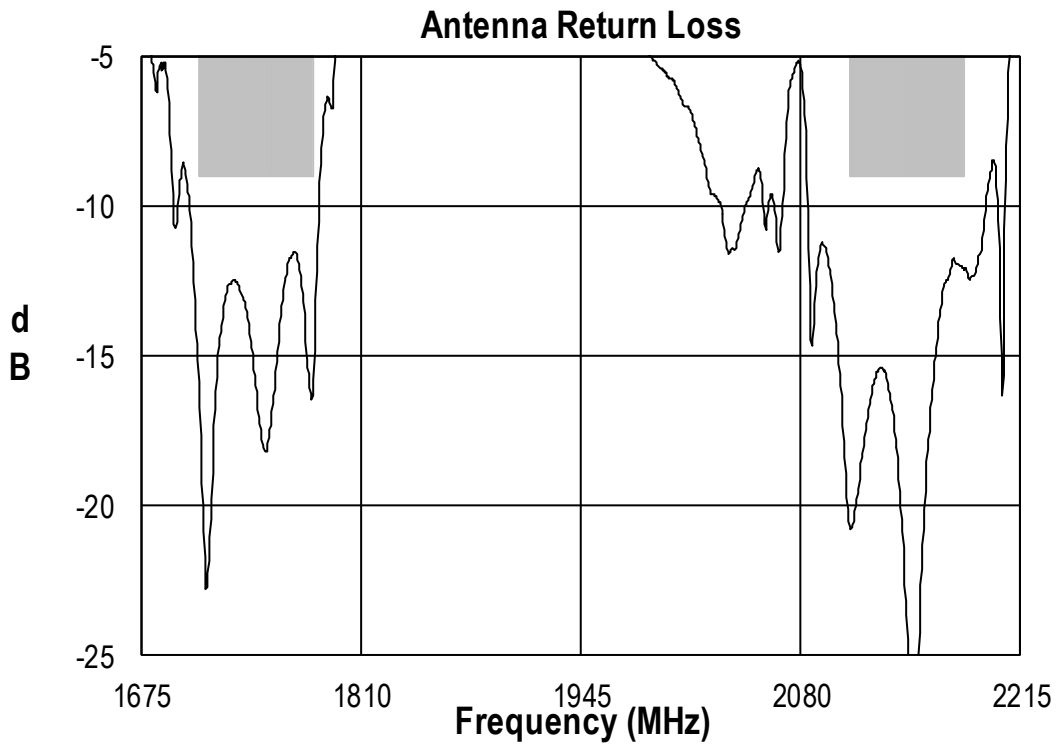
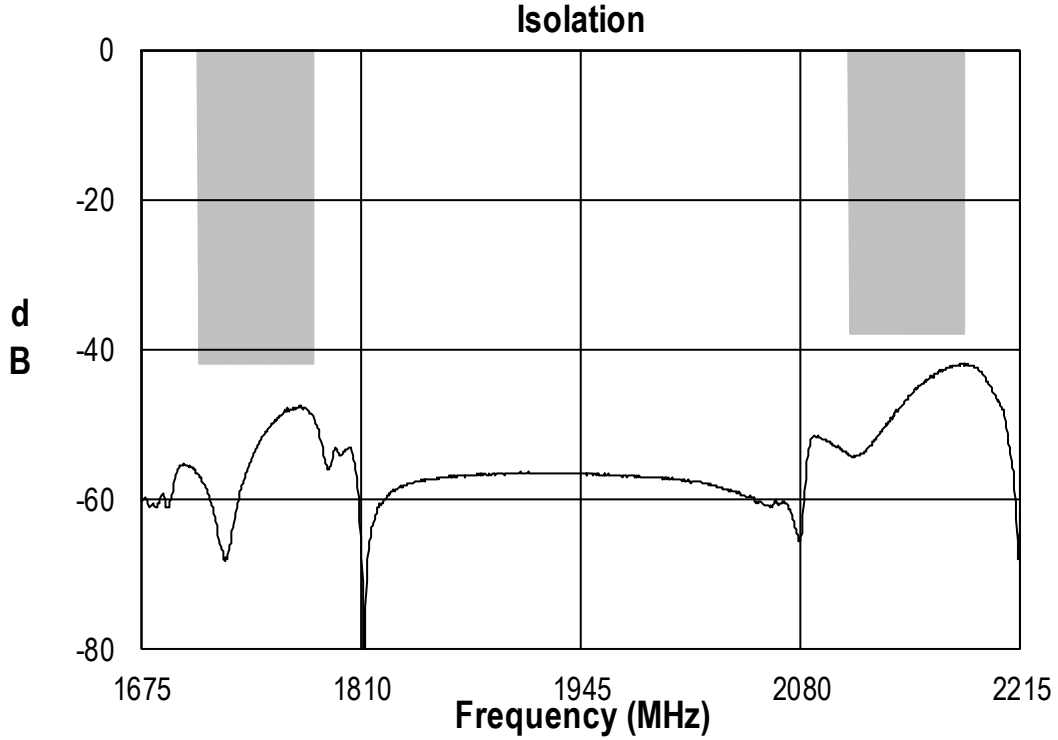

Package Marking

Qorvo Logo
 Product Identifier: 1289
 Trace Code: XXXX



PCB Mounting Pattern

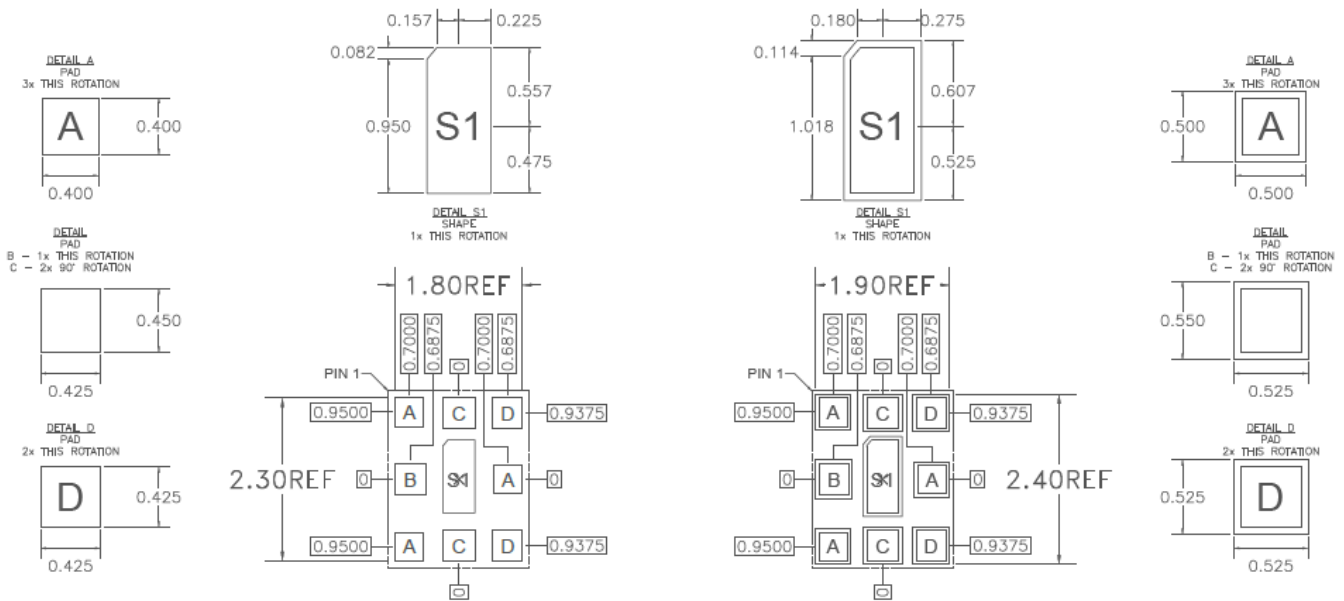

RECOMMENDED
 LAND PATTERN

RECOMMENDED
 LAND PATTERN MASK

- Notes:
1. All dimensions are in millimeters. Angles are in degrees.
 2. This drawing specifies the mounting pattern used on the Qorvo evaluation board for this product. Some modification may be necessary to suit end user assembly materials and processes.

Tape and Reel Information – Carrier and Cover Tape Dimensions

Tape and reel specifications for this part are also available on the Qorvo website.
 Standard T/R size = 2500 pieces on a 7" reel.

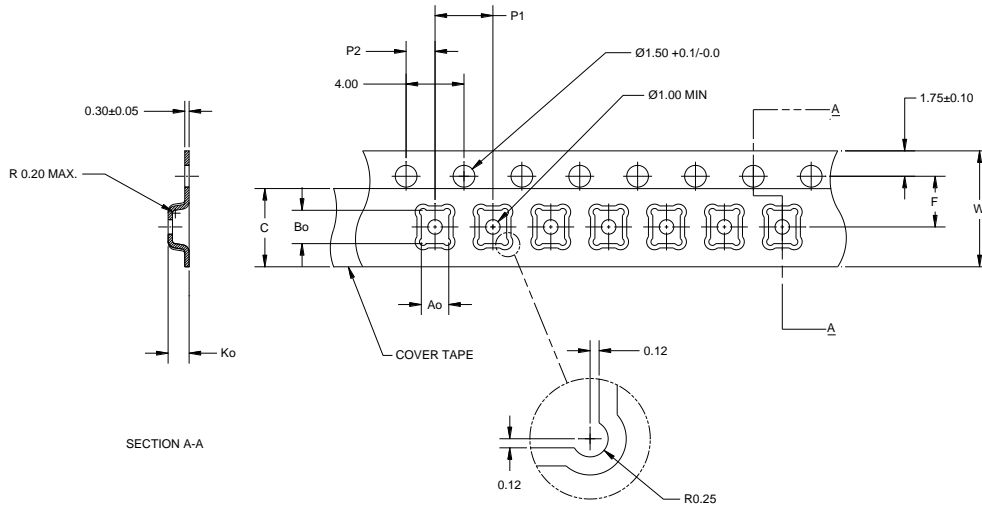

Feature	Measure	Symbol	Size (in)	Size (mm)
Cavity	Length	A0	0.092	2.34
	Width	B0	0.112	2.85
	Depth	K0	0.043	1.10
	Pitch	P1	0.157	4.00
Centerline Distance	Cavity to Perforation - Length Direction	P2	0.079	2.00
	Cavity to Perforation - Width Direction	F	0.138	3.50
Cover Tape	Width	C	0.213	5.40
Carrier Tape	Width	W	0.315	8.00

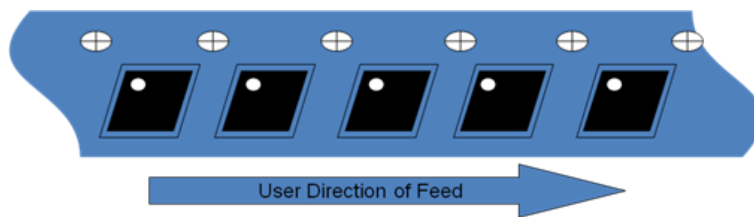

Tape and Reel Information – Reel Dimensions

Tape and reel specifications for this part are also available on the Qorvo website.
 Standard T/R size = 2500 pieces on a 7" reel.

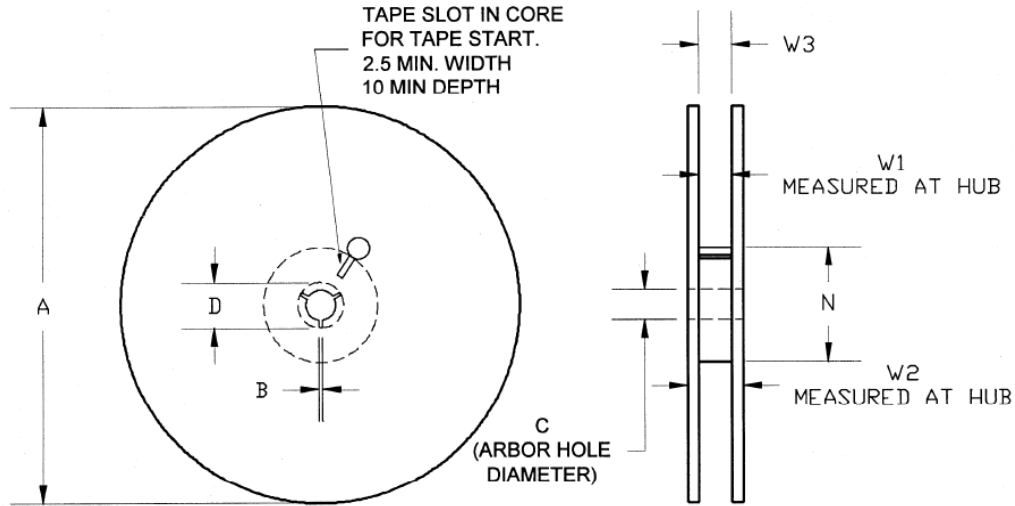

Feature	Measure	Symbol	Size (in)	Size (mm)
Flange	Diameter	A	6.969	177.0
	Thickness	W2	0.559	14.2
	Space Between Flange	W1	0.346	8.8
Hub	Outer Diameter	N	2.283	58.0
	Arbor Hole Diameter	C	0.512	13.0
	Key Slit Width	B	0.079	2.0
	Key Slit Diameter	D	0.787	20.0

Assembly Notes

Compatible with both Lead-free solder (260°C peak reflow temperature) and tin/lead (245°C peak reflow temp.) soldering processes

Contact plating: Bussed NiAu

Recommended Soldering Profile

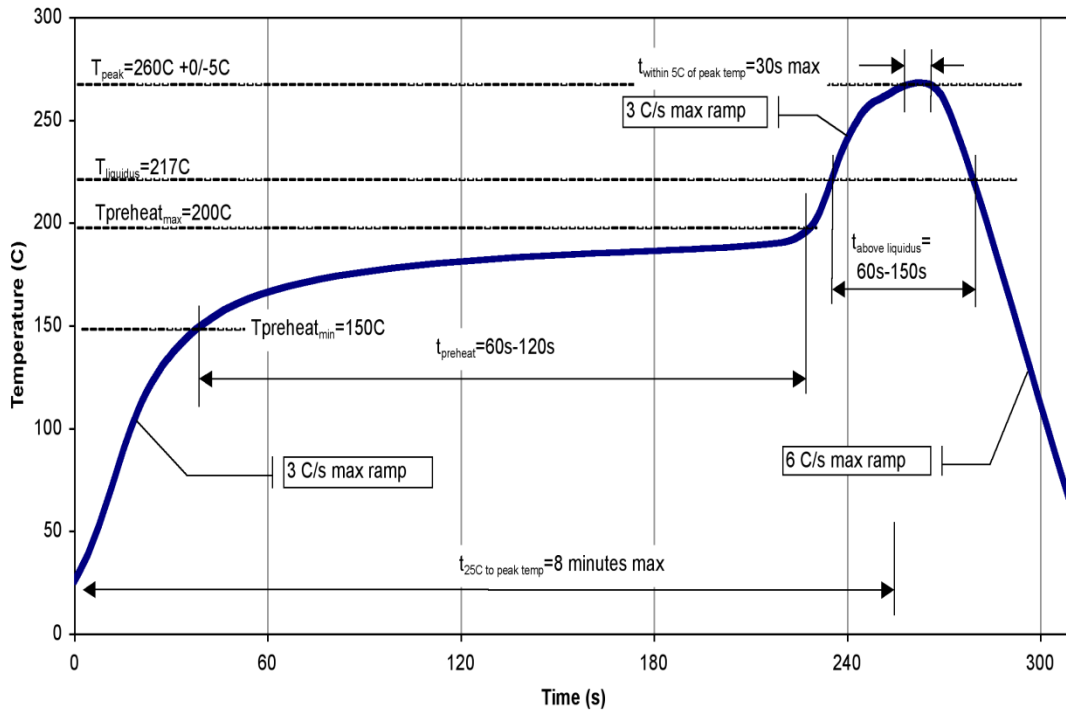

Handling Precautions

Parameter	Rating	Standard
ESD – Human Body Model (HBM)	Class 1C	ESDA / JEDEC JS-001-2012
ESD – Charged Device Model (CDM)	Class C3	ESDA / JEDEC JS-002-2014
MSL – Moisture Sensitivity Level	Level 3	IPC/JEDEC J-STD-020



Caution!
ESD-Sensitive Device

RoHS Compliance

This part is compliant with 2011/65/EU RoHS directive (Restrictions on the Use of Certain Hazardous Substances in Electrical and Electronic Equipment) as amended by Directive 2015/863/EU.

This product also has the following attributes:

- Lead Free
- Halogen Free (Chlorine, Bromine)
- Antimony Free
- TBBP-A (C₁₅H₁₂Br₄O₂) Free
- PFOS Free
- SVHC Free



Contact Information

For the latest specifications, additional product information, worldwide sales and distribution locations:

Web: www.qorvo.com

Tel: 1-844-890-8163

Email: customer.support@qorvo.com

Important Notice

The information contained herein is believed to be reliable; however, Qorvo makes no warranties regarding the information contained herein and assumes no responsibility or liability whatsoever for the use of the information contained herein. All information contained herein is subject to change without notice. Customers should obtain and verify the latest relevant information before placing orders for Qorvo products. The information contained herein, or any use of such information does not grant, explicitly or implicitly, to any party any patent rights, licenses, or any other intellectual property rights, whether with regard to such information itself or anything described by such information. **THIS INFORMATION DOES NOT CONSTITUTE A WARRANTY WITH RESPECT TO THE PRODUCTS DESCRIBED HEREIN, AND QORVO HEREBY DISCLAIMS ANY AND ALL WARRANTIES WITH RESPECT TO SUCH PRODUCTS WHETHER EXPRESS OR IMPLIED BY LAW, COURSE OF DEALING, COURSE OF PERFORMANCE, USAGE OF TRADE OR OTHERWISE, INCLUDING THE IMPLIED WARRANTIES OF MERCHANTABILITY AND FITNESS FOR A PARTICULAR PURPOSE.**

Without limiting the generality of the foregoing, Qorvo products are not warranted or authorized for use as critical components in medical, lifesaving, or life-sustaining applications, or other applications where a failure would reasonably be expected to cause severe personal injury or death.

Copyright 2021 © Qorvo, Inc. | Qorvo is a registered trademark of Qorvo, Inc.

X-ON Electronics

Largest Supplier of Electrical and Electronic Components

Click to view similar products for [RF Development Tools](#) category:

Click to view products by [Qorvo](#) manufacturer:

Other Similar products are found below :

[MAAM-011117](#) [MAAP-015036-DIEEV2](#) [EV1HMC1113LP5](#) [EV1HMC6146BLC5A](#) [EV1HMC637ALP5](#) [EVAL-ADG919EBZ](#) [ADL5363-EVALZ](#) [LMV228SDEVAL](#) [SKYA21001-EVB](#) [SMP1331-085-EVB](#) [EV1HMC618ALP3](#) [EVAL01-HMC1041LC4](#) [MAAL-011111-000SMB](#)
[MAAM-009633-001SMB](#) [MASW-000936-001SMB](#) [107712-HMC369LP3](#) [107780-HMC322ALP4](#) [SP000416870](#) [EV1HMC470ALP3](#)
[EV1HMC520ALC4](#) [EV1HMC244AG16](#) [MAX2614EVKIT#](#) [124694-HMC742ALP5](#) [SC20ASATEA-8GB-STD](#) [MAX2837EVKIT+](#)
[MAX2612EVKIT#](#) [MAX2692EVKIT#](#) [EV1HMC629ALP4E](#) [SKY12343-364LF-EVB](#) [108703-HMC452QS16G](#) [EV1HMC863ALC4](#)
[EV1HMC427ALP3E](#) [119197-HMC658LP2](#) [EV1HMC647ALP6](#) [ADL5725-EVALZ](#) [MAX2371EVKIT#](#) [106815-HMC441LM1](#)
[EV1HMC1018ALP4](#) [UXN14M9PE](#) [MAX2016EVKIT](#) [EV1HMC939ALP4](#) [MAX2410EVKIT](#) [MAX2204EVKIT+](#) [EV1HMC8073LP3D](#)
[SIMSA868-DKL](#) [SIMSA868C-DKL](#) [SKY65806-636EK1](#) [SKY68020-11EK1](#) [SKY67159-396EK1](#) [SKY66181-11-EK1](#)