

Product Overview

The QPQ1297 is a high-performance Bulk Acoustic Wave (BAW) Duplexer designed for Band 3 uplink/downlink applications.

The QPQ1297 provides low insertion loss and high rejection making it an ideal choice for Small Cells. This duplexer is housed in a compact, RoHs compliant 2.00 mm x 2.50 mm x 0.93 mm surface mount package (SMP).

The QPQ1297 is part of Qorvo's extensive portfolio of RF BAW and SAW filters.

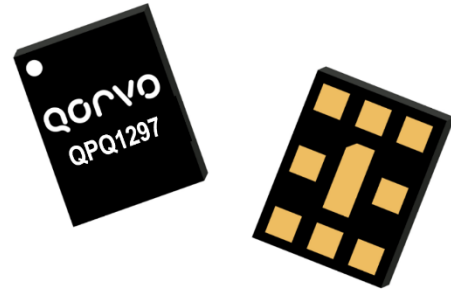

9 Pad 2.00 mm x 2.50 mm x 0.93 mm SMP

Functional Block Diagram

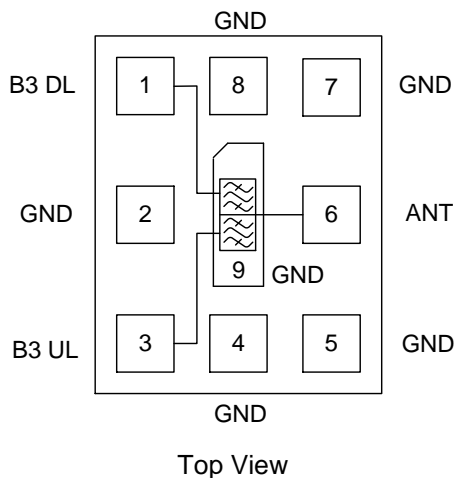

Pin Configuration

Pin No.	Label	Function
1	B3 DL	Downlink port
2, 4, 5, 7, 8, 9	GND	Ground connections
3	B3 UL	Uplink port
6	ANT	Antenna port

Key Features

- 75 MHz Bandwidth – Band 3 Up Link
- 75 MHz Bandwidth – Band 3 Down Link
- High Attenuation
- Low Loss
- No External Matching Required
- Single Input, Single Output Operation
- Small Size: 2.00 mm x 2.50 mm x 0.93 mm
- Surface Mount Package (SMP)
- RoHS Compliant, Pb-Free

Applications

- Band 3
- Base Station Infrastructure
- Small Cells
- Repeaters
- Routers
- LTE Dongles
- General Purpose Wireless

Ordering Information

Part No.	Description
QPQ1297TR7	2,500 pieces on a 7" reel (standard)
QPQ1297EVB	Evaluation Board

Absolute Maximum Ratings

Parameter	Rating
Storage Temperature	-40 to +125°C
Operation Temperature	-40 to +95°C

Life Test

Conditions	Rating
+30 dBm DL ⁽¹⁾ , +85°C ⁽³⁾	> 293,000 hours
+23 dBm UL ⁽²⁾ , +85°C ⁽³⁾	> 293,000 hours
+30 dBm DL ⁽¹⁾ , +95°C ⁽³⁾	> 102,000 hours
+23 dBm UL ⁽²⁾ , +95°C ⁽³⁾	> 102,000 hours

Notes:

1. Power injected into Pin 1 downlink port
2. Power injected into Pin 6 antenna port
3. FD-LTE, 5MHz 16QAM, PAR =8dB

Electrical Specifications ⁽⁴⁾ – Band 3 Uplink

Test conditions unless otherwise specified. Temperature Range: -40 to +95 °C

Parameter ⁽⁵⁾	Conditions	Min	Typ ⁽⁶⁾	Max	Units
Passband		1710	–	1785	MHz
Max Insertion Loss	1710 – 1785 MHz	–	2.3–	4.1	dB
Average Insertion Loss	1710 – 1715 MHz	–	1.8	2.6	
	1715 – 1780 MHz (Over any 5 MHz bandwidth)	–	1.6	2.4	
Amplitude Ripple ⁽⁷⁾	1710 – 1785 MHz	–	0.7	2.2	dB
	1710 – 1785 MHz (Over any 5 MHz bandwidth)	–	11.9	25.0	ns
Group Delay Variation	1710 – 1785 MHz	–	26.9	48.0	ns
	1710 – 1785 MHz (Over any 5 MHz bandwidth)	–	11.9	25.0	ns
Input / Output VSWR	1710 – 1785 MHz	–	1.7:1	2.0:1	
Attenuation ⁽⁸⁾	10 – 700 MHz	30	38	–	dB
	700 – 1000 MHz	38	39	–	
	1000 – 1400 MHz	20	40	–	
	1400 – 1600 MHz	35	40	–	
	1600 – 1685 MHz (Over any 5 MHz bandwidth)	19	28	–	
	1685 – 1690 MHz (Over any 5 MHz bandwidth)	10	24	–	
	1805 – 1850 MHz (Over any 5 MHz bandwidth)	44	56	–	
	1850 – 1855 MHz (Over 5 MHz bandwidth)	48	53	–	
	1855 – 1875 MHz (Over any 5 MHz bandwidth)	47	50	–	
	1875 – 1880 MHz (Over 5 MHz bandwidth)	47	50	–	
	1880 – 1920 MHz	38	48	–	
	1920 – 1980 MHz	30	45	–	
	1980 – 2110 MHz	38	46	–	
	2110 – 2170 MHz	40	50	–	
	2170 – 2690 MHz	32	39	–	
	2690 – 3400 MHz	13	19	–	
3400 – 3800 MHz	6	9	–		
3800 – 5150 MHz	2	4	–		
5150 – 6000 MHz	7	9	–		
EVM	1712.5 – 1782.5 MHz	–	3		%
Source/Load Impedance ⁽⁹⁾	Single-ended	–	50	–	Ω

Notes:

4. All specifications are based on the Qorvo schematic for the main reference design.
5. Electrical margin has been built into the design to account for the variations due to temperature drift and manufacturing tolerances.
6. Typical values are based on average measurements of 12 devices at room temperature.
7. This is defined as the worst difference between a peak and adjacent valley within defined frequency points.
8. Relative to zero dB.
9. This is the optimum impedance in order to achieve the performance shown.

Electrical Specifications ⁽¹⁾ – Band 3 Uplink

Test conditions unless otherwise specified. Temperature Range: -40 to +85 °C

Parameter ⁽²⁾	Conditions	Min	Typ ⁽³⁾	Max	Units
Passband		1710	–	1785	MHz
Max Insertion Loss	1710 – 1785 MHz	–	2.3	3.8	dB
Average Insertion Loss	1710 – 1715 MHz	–	1.8	2.6	
	1715 – 1780 MHz (Over any 5 MHz bandwidth)	–	1.6	2.4	
	1780 – 1785 MHz	–	2.1	3.0	dB
Amplitude Ripple ⁽⁴⁾	1710 – 1785 MHz	–	0.7	2.2	dB
Group Delay Variation	1710 – 1785 MHz	–	26.9	45.0	ns
	1710 – 1785 MHz (Over any 5 MHz bandwidth)	–	10.5	25.0	ns
Input / Output VSWR	1710 – 1785 MHz	–	1.7:1	2.0:1	
Attenuation ⁽⁵⁾	10 – 700 MHz	30	38	–	dB
	700 – 1000 MHz	38	39	–	
	1000 – 1400 MHz	20	40	–	
	1400 – 1600 MHz	35	40	–	
	1600 – 1685 MHz (Over any 5 MHz bandwidth)	23	28	–	
	1685 – 1690 MHz (Over 5 MHz bandwidth)	12	24	–	
	1805 – 1850 MHz (Over any 5 MHz bandwidth)	50	56	–	
	1850 – 1855 MHz (Over 5 MHz bandwidth)	48	53	–	
	1855 – 1875 MHz (Over any 5 MHz bandwidth)	47	50	–	
	1875 – 1880 MHz (Over 5 MHz bandwidth)	47	50	–	
	1880 – 1920 MHz	38	48	–	
	1920 – 1980 MHz	30	45	–	
	1980 – 2110 MHz	38	46	–	
	2110 – 2170 MHz	40	50	–	
	2170 – 2690 MHz	34	39	–	
2690 – 3400 MHz	13	19	–		
3400 – 3800 MHz	6.5	9	–		
3800 – 5150 MHz	3	4	–		
5150 – 6000 MHz	7	9	–		
EVM	1712.5 – 1782.5 MHz	–	3		%
Source/Load Impedance ⁽⁶⁾	Single-ended	–	50	–	Ω

Notes:

1. All specifications are based on the Qorvo schematic for the main reference design.
2. Electrical margin has been built into the design to account for the variations due to temperature drift and manufacturing tolerances.
3. Typical values are based on average measurements of 12 devices at room temperature.
4. This is defined as the worst difference between a peak and adjacent valley within defined frequency points.
5. Relative to zero dB.
6. This is the optimum impedance in order to achieve the performance shown.

Electrical Specifications ⁽¹⁾ – Band 3 Downlink

Test conditions unless otherwise specified. Temperature Range: -40 to +95 °C

Parameter ⁽²⁾	Conditions	Min	Typ ⁽³⁾	Max	Units
Passband		1805	–	1880	MHz
Max Insertion Loss	1805 – 1880 MHz (-40 to +95 °C)	–	2.8	4.0	dB
	1812.5 – 1872.5 MHz (-40 to +95 °C)	–	2.2	2.7	
Average Insertion Loss	1805 – 1810 MHz (-40 to +95 °C)	–	2.3	2.8	dB
	1810 – 1875 MHz (-40 to +95 °C) (Over any 5 MHz bandwidth)	–	2.2	2.7	
	1875 – 1880 MHz (-40 to +95 °C)	–	2.4	3.4	
Amplitude Ripple ⁽⁴⁾	1805 – 1880 MHz (-40 to +95 °C)	–	0.7	2.2	dB
Group Delay Variation	1805 – 1880 MHz (-40 to +95 °C)	–	23.2	40.0	ns
	1805 – 1880 MHz (-40 to +95 °C) (Over any 5 MHz bandwidth)	–	11.7	25.0	ns
Input / Output VSWR	1805 – 1880 MHz	–	2.4:1	2.6:1	
Attenuation ⁽⁵⁾	10 – 700 MHz	20	44	–	dB
	880 – 915 MHz	28	30	–	
	700 – 1000 MHz	26	28	–	
	1000 – 1400 MHz	23	26	–	
	1400 – 1600 MHz	35	38	–	
	1600 – 1710 MHz	20	52	–	
	1710 – 1770 MHz (Over any 5 MHz bandwidth)	52	57	–	
	1770 – 1775 MHz (Over 5 MHz bandwidth)	50	63	–	
	1775 – 1785 MHz (Over any 5 MHz bandwidth)	53	59	–	
	1920 – 1925 MHz (Over 5 MHz bandwidth)	53	56	–	
	1925 – 1930 MHz (Over 5 MHz bandwidth)	54	59	–	
	1930 – 1965 MHz (Over any 5 MHz bandwidth)	55	57	–	
	1965 – 1980 MHz (Over any 5 MHz bandwidth)	48	55	–	
	1980 – 2300 MHz	30	55	–	
	2300 – 2400 MHz	49	55	–	
	2400 – 2690 MHz	45	59	–	
	2690 – 3400 MHz	25	46	–	
3400 – 3800 MHz	45	53	–		
3800 – 5150 MHz	20	44	–		
5150 – 6000 MHz	28	31	–		
EVM	1807.5 – 1877.5 MHz (-40 to +95 °C)	–	3	–	%
Source/Load Impedance ⁽⁶⁾	Single-ended	–	50	–	Ω

Notes:

1. All specifications are based on the Qorvo schematic for the main reference design.
2. Electrical margin has been built into the design to account for the variations due to temperature drift and manufacturing tolerances.
3. Typical values are based on average measurements of 12 devices at room temperature.
4. This is defined as the worst difference between a peak and adjacent valley within defined frequency points.
5. Relative to zero dB.
6. This is the optimum impedance in order to achieve the performance shown.

Electrical Specifications ⁽¹⁾ – Band 3 Downlink

Test conditions unless otherwise specified. Temperature Range: -40 to +85 °C

Parameter ⁽²⁾	Conditions	Min	Typ ⁽³⁾	Max	Units
Passband		1805	–	1880	MHz
Max Insertion Loss	1805 – 1880 MHz	–	2.8	4.0	dB
	1812.5 – 1872.5 MHz	–	2.2	2.7	
Average Insertion Loss	1805 – 1810 MHz	–	2.3	2.8	dB
	1810 – 1875 MHz (Over any 5 MHz bandwidth)	–	2.2	2.5	
	1875 – 1880 MHz	–	2.4	3.1	
Amplitude Ripple ⁽⁴⁾	1805 – 1880 MHz	–	0.7	2.2	dB
Group Delay Variation	1805 – 1880 MHz	–	23.2	40.0	ns
	1805 – 1880 MHz (Over any 5 MHz bandwidth)	–	11.7	25.0	ns
Input / Output VSWR	1805 – 1880 MHz	–	2.4:1	2.5:1	
Attenuation ⁽⁵⁾	10 – 700 MHz	20	44	–	dB
	880 – 915 MHz	28	30	–	
	700 – 1000 MHz	26	28	–	
	1000 – 1400 MHz	23	26	–	
	1400 – 1600 MHz	35	38	–	
	1600 – 1710 MHz	20	52	–	
	1710 – 1770 MHz (Over any 5 MHz bandwidth)	53	57	–	
	1770 – 1775 MHz (Over 5 MHz bandwidth)	50	63	–	
	1775 – 1785 MHz (Over any 5 MHz bandwidth)	53	59	–	
	1920 – 1925 MHz (Over 5 MHz bandwidth)	53	56	–	
	1925 – 1930 MHz (Over 5 MHz bandwidth)	54	59	–	
	1930 – 1965 MHz (Over any 5 MHz bandwidth)	55	57	–	
	1965 – 1980 MHz (Over any 5 MHz bandwidth)	52	55	–	
	1980 – 2300 MHz	30	55	–	
	2300 – 2400 MHz	49	59	–	
	2400 – 2690 MHz	45	59	–	
2690 – 3400 MHz	25	46	–		
3400 – 3800 MHz	45	53	–		
3800 – 5150 MHz	20	44	–		
5150 – 6000 MHz	28	31	–		
EVM	1807.5 – 1877.5 MHz	–	3	–	%
Source/Load Impedance ⁽⁶⁾	Single-ended	–	50	–	Ω

Notes:

1. All specifications are based on the Qorvo schematic for the main reference design.
2. Electrical margin has been built into the design to account for the variations due to temperature drift and manufacturing tolerances.
3. Typical values are based on average measurements of 12 devices at room temperature.
4. This is defined as the worst difference between a peak and adjacent valley within defined frequency points.
5. Relative to zero dB.
6. This is the optimum impedance in order to achieve the performance shown.

Electrical Specifications ⁽¹⁾ – Band 3 Isolation

Test conditions unless otherwise specified. Temperature Range: -40 to +95 °C

Parameter ⁽²⁾	Conditions	Min	Typ ⁽³⁾	Max	Units
Isolation	1710 – 1780 MHz	54	56	–	dB
	1780 – 1785 MHz	53	64	–	dB
	1805 – 1875 MHz	45	51	–	dB
	1875 – 1880 MHz	47	51	–	dB
Source/Load Impedance ⁽⁴⁾	Single-ended	–	50	–	Ω

Notes:

1. All specifications are based on the Qorvo schematic for the main reference design.
2. Electrical margin has been built into the design to account for the variations due to temperature drift and manufacturing tolerances.
3. Typical values are based on average measurements of 12 devices at room temperature.
4. This is the optimum impedance in order to achieve the performance shown.

Electrical Specifications ⁽⁵⁾ – Band 3 Isolation

Test conditions unless otherwise specified. Temperature Range: -40 to +85 °C

Parameter ⁽⁶⁾	Conditions	Min	Typ ⁽⁷⁾	Max	Units
Isolation	1710 – 1780 MHz	54	56	–	dB
	1780 – 1785 MHz	53	64	–	dB
	1805 – 1875 MHz	48	51	–	dB
	1875 – 1880 MHz	48	51	–	dB
Source/Load Impedance ⁽⁸⁾	Single-ended	–	50	–	Ω

Notes:

5. All specifications are based on the Qorvo schematic for the main reference design.
6. Electrical margin has been built into the design to account for the variations due to temperature drift and manufacturing tolerances.
7. Typical values are based on average measurements of 12 devices at room temperature.
8. This is the optimum impedance in order to achieve the performance shown.

QPQ1297EVB Evaluation Board

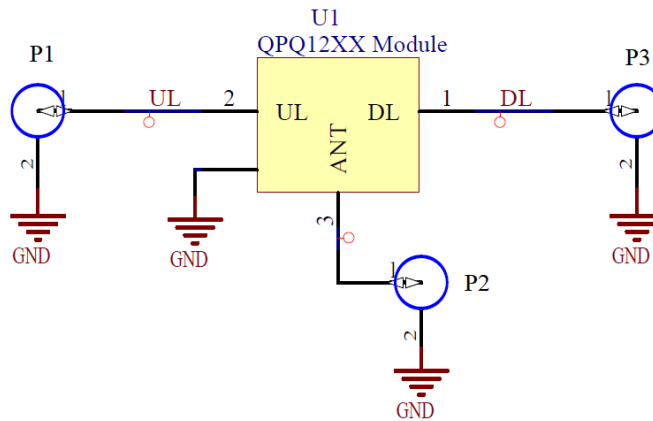
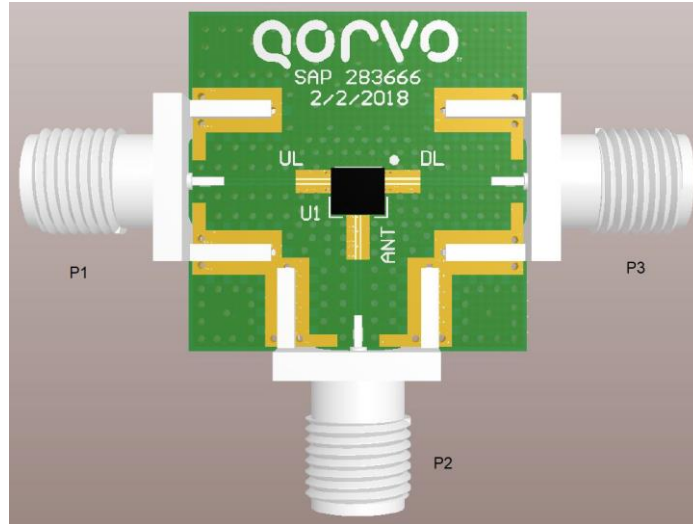

Bill of Material – QPQ1297EVB

Reference Designation	Description	Manufacture	Part Number
U1	Duplexer, Band 3 BAW	Qorvo	QPQ1297
P1, P2, P3	Connector, SMA RF	Radiall USA Inc.	9602-1111-018
PCB	Printed Circuit Board, Evaluation	Multiple	283666

Performance Plots Band 3 Uplink

Test conditions unless otherwise noted: Temp= +25°C

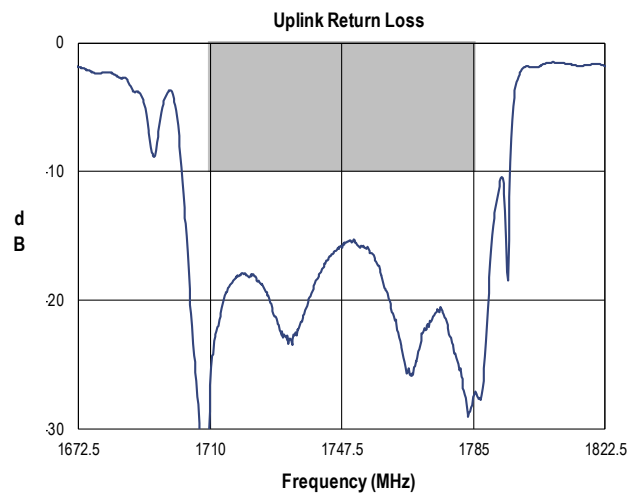
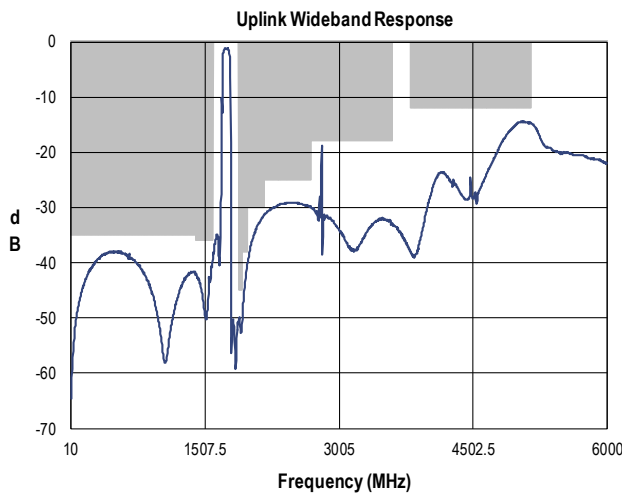
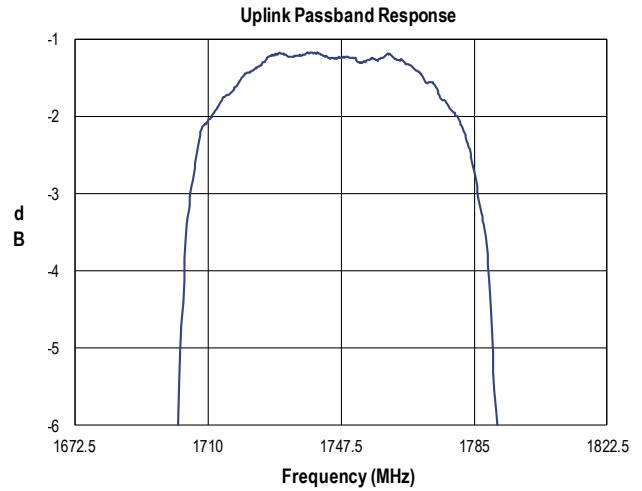
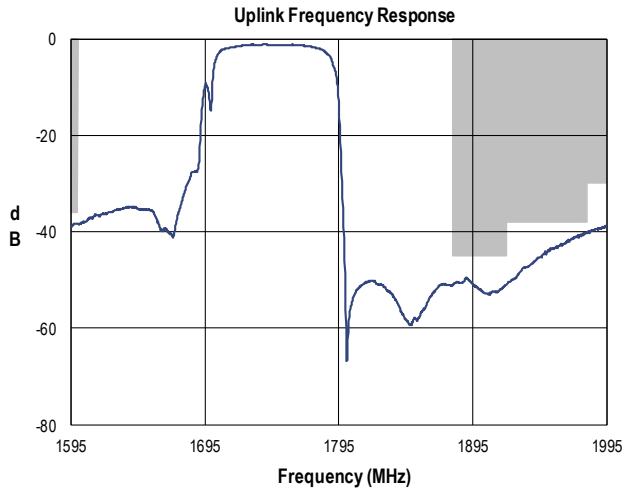

Uplink Path - Ant Port Impedance

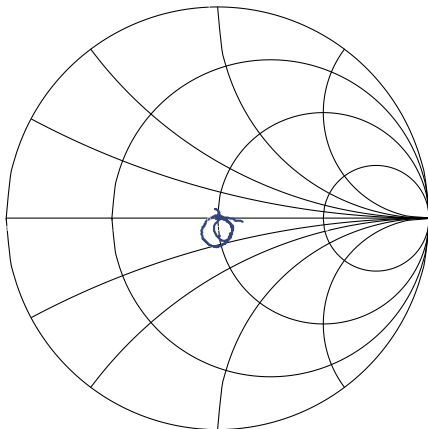

Uplink Port Impedance

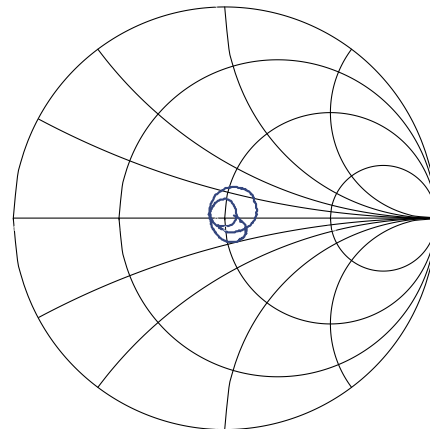

Performance Plots Band 3 Downlink

Test conditions unless otherwise noted: Temp= +25°C

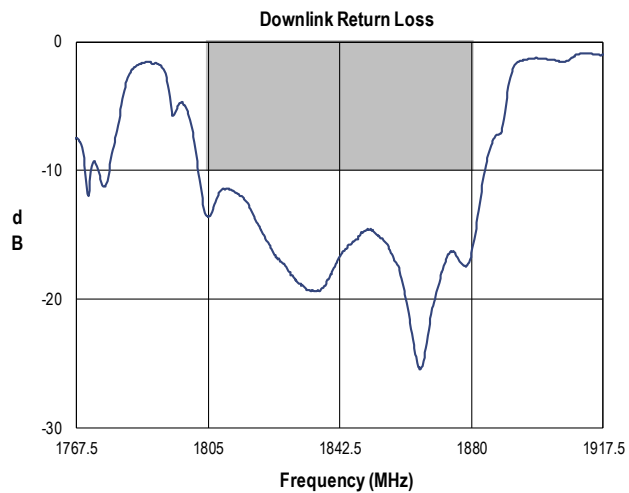
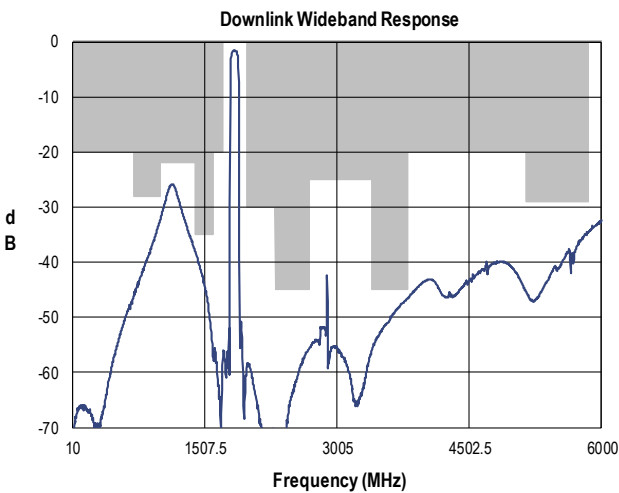
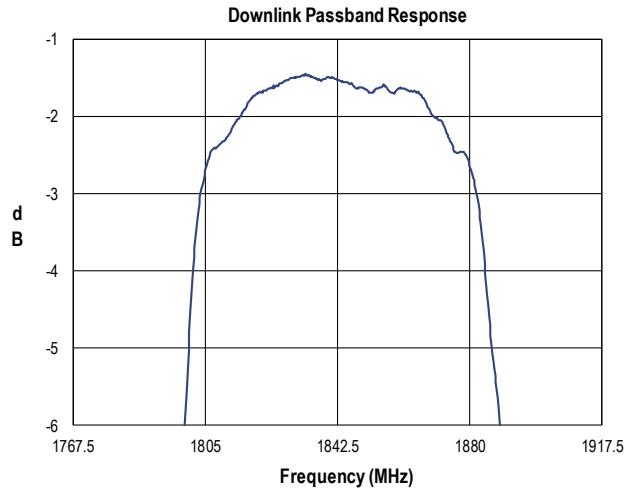
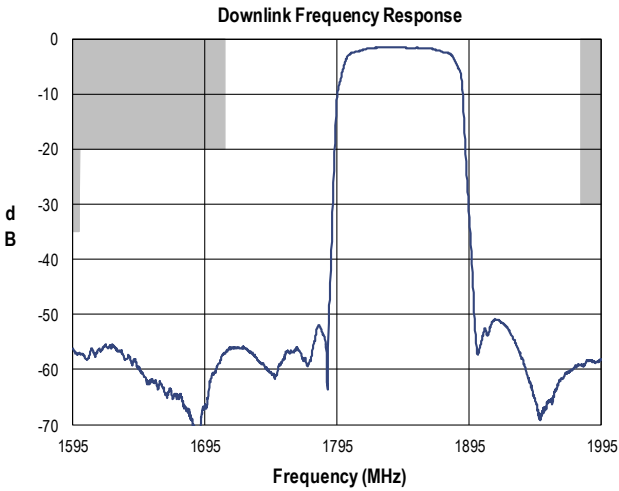

Downlink Path - Ant Port Impedance

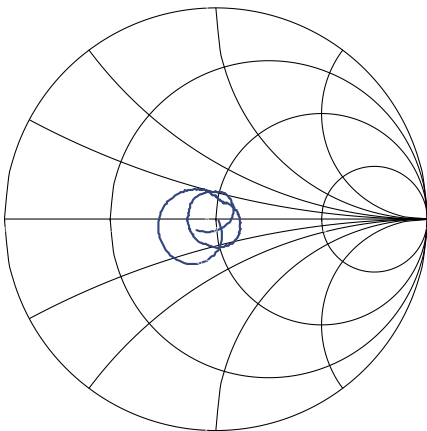

Downlink Port Impedance

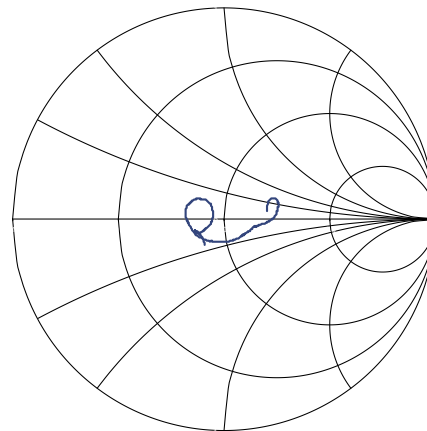

Performance Plots Isolation

Test conditions unless otherwise noted: Temp= +25°C

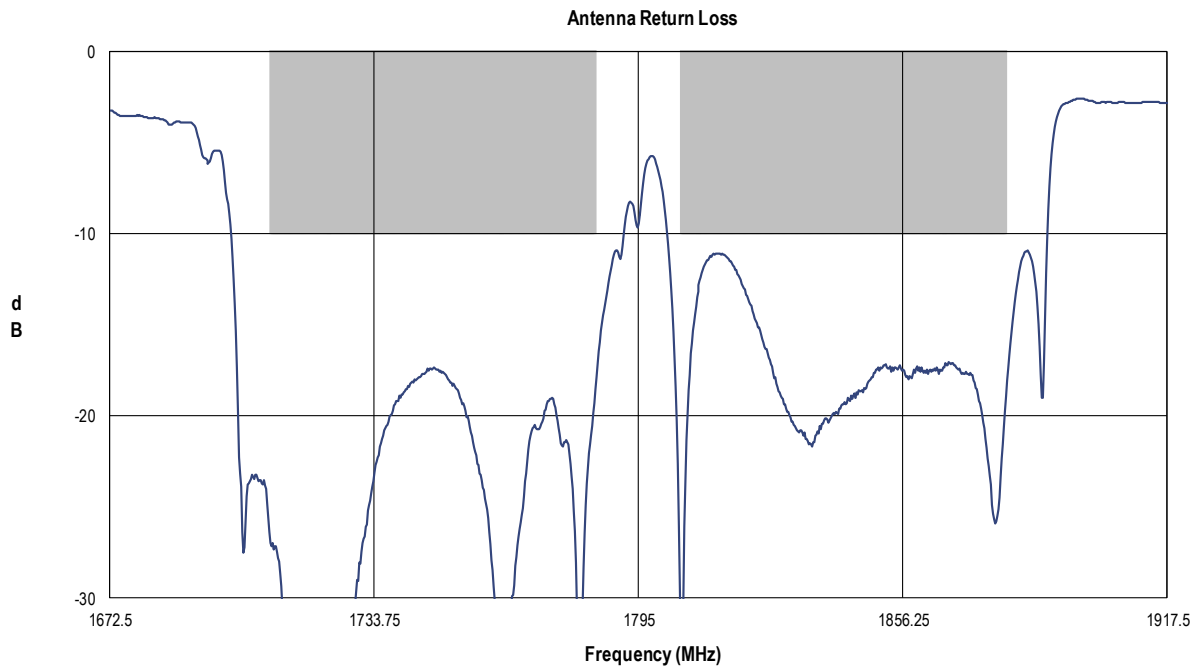
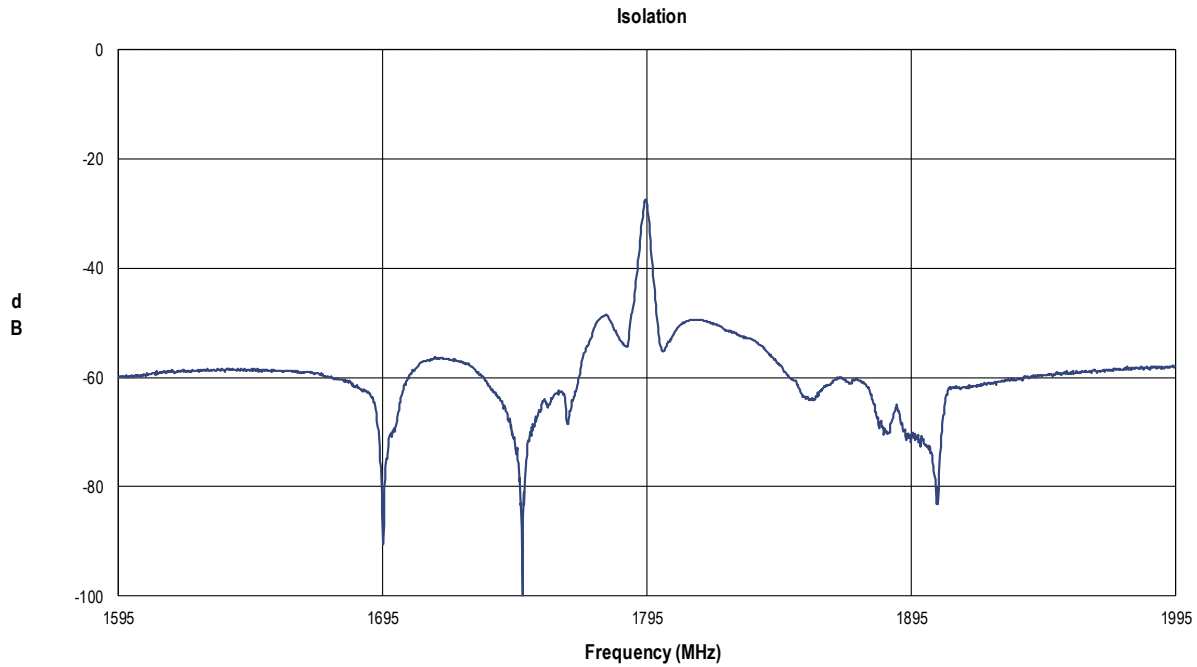

Package Dimensions

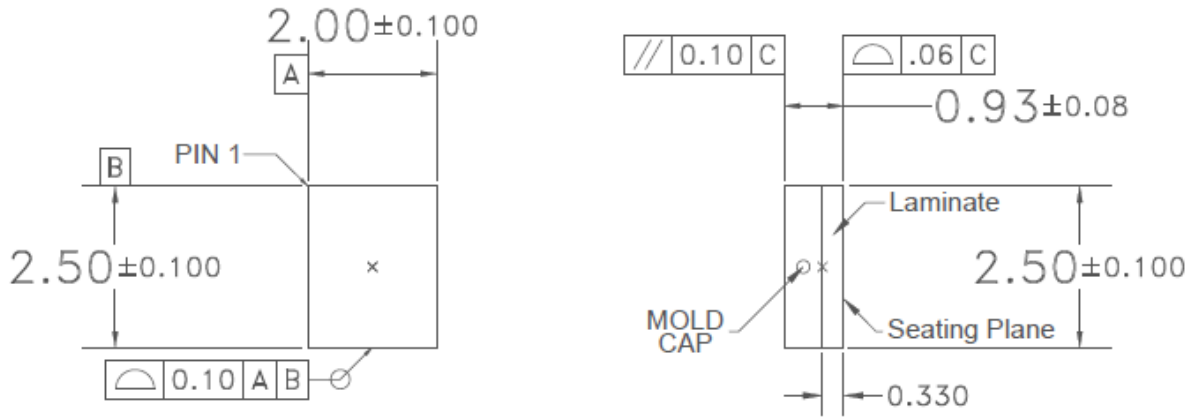

TOP VIEW

SIDE VIEW

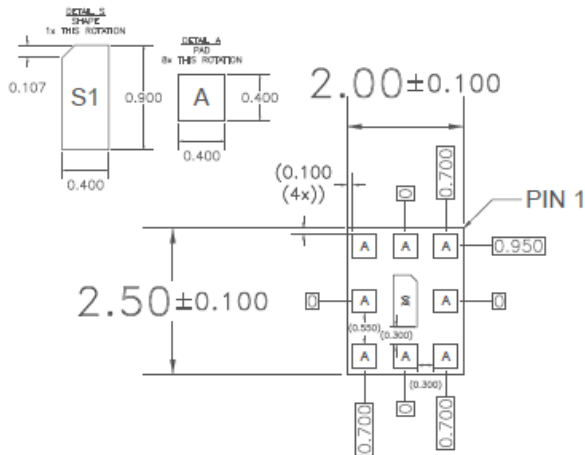

BOTTOM VIEW

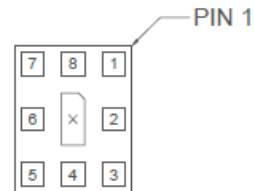

BOTTOM PINS VIEW

Notes:

1. All dimensions are in millimeters. Angles are in degrees.
2. Dimension and tolerance formats conform to ASME Y14.4M-1994.
3. The terminal #1 identifier and terminal numbering conform to JESD 95-1 SPP-012.

Package Marking

Package Marking

Qorvo Logo
Product Identifier: 1297
Trace Code: XXXX

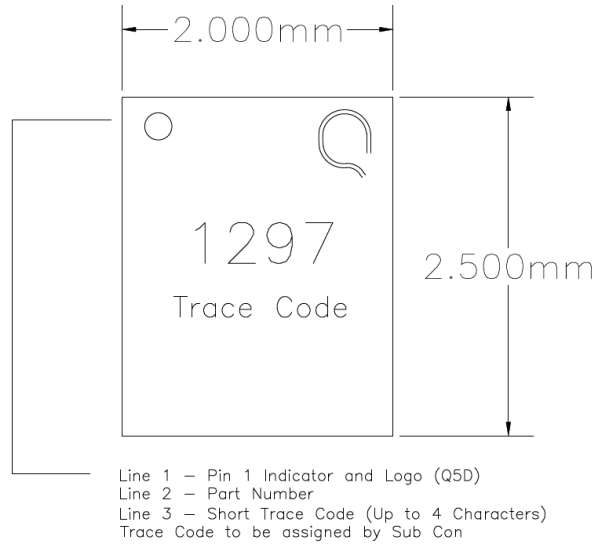

PCB Mounting Pattern

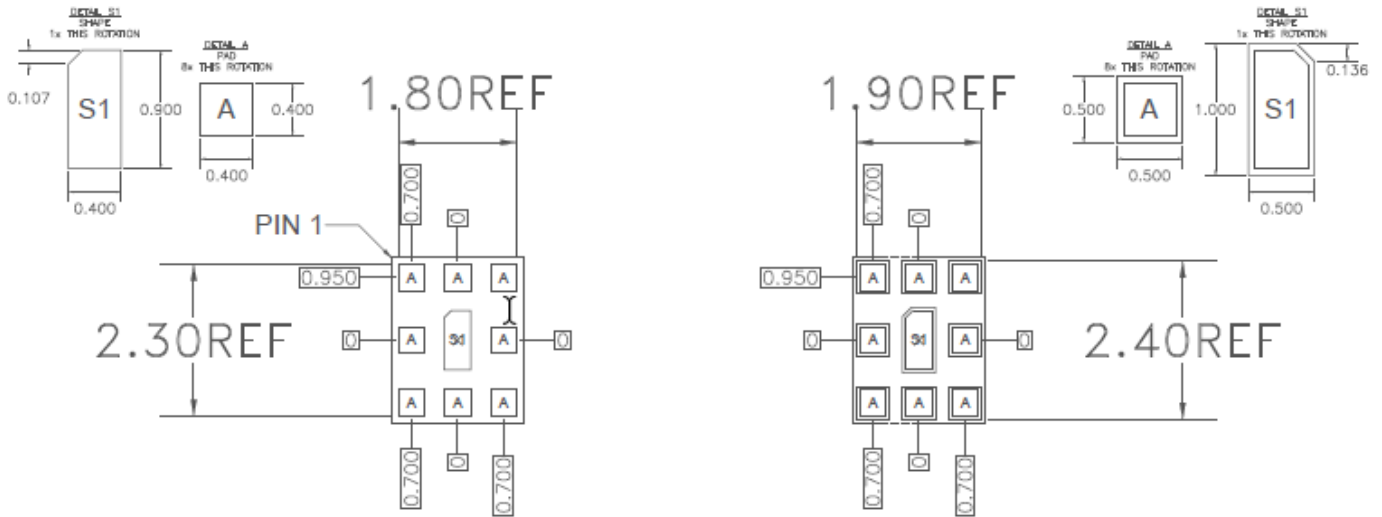

RECOMMENDED
LAND PATTERN

RECOMMENDED
LAND PATTERN MASK

Notes:

1. All dimensions are in millimeters. Angles are in degrees.
2. This drawing specifies the mounting pattern used on the Qorvo evaluation board for this product. Some modification may be necessary to suit end user assembly materials and processes.

Tape and Reel Information – Carrier and Cover Tape Dimensions

Tape and reel specifications for this part are also available on the Qorvo website.
 Standard T/R size = 2500 pieces on a 7” reel.

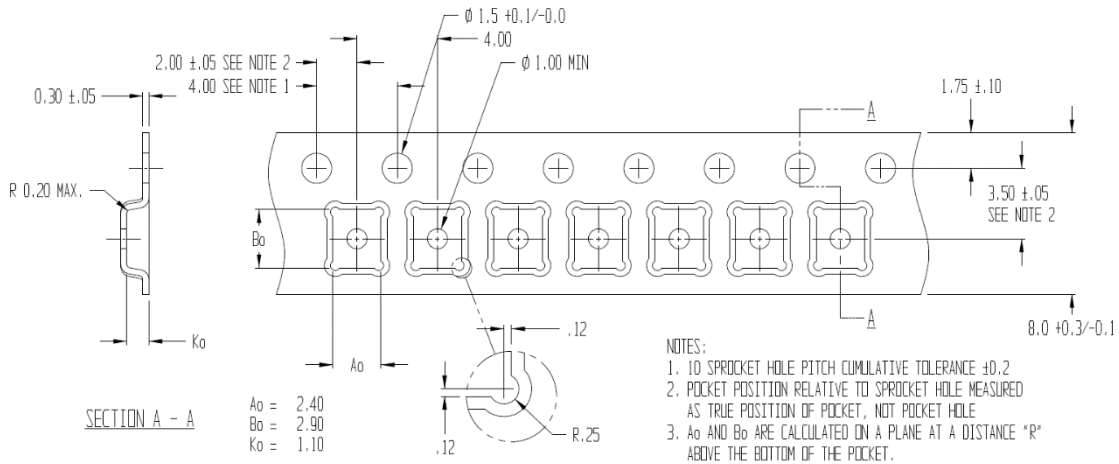

Feature	Measure	Symbol	Size (in)	Size (mm)
Cavity	Length	A0	0.094	2.40
	Width	B0	0.114	2.90
	Depth	K0	0.043	1.10
	Pitch	P1	0.157	4.00
Centerline Distance	Cavity to Perforation - Length Direction	P2	0.079	2.00
	Cavity to Perforation - Width Direction	F	0.138	3.50
Cover Tape	Width	C	0.213	5.40
Carrier Tape	Width	W	0.315	8.00

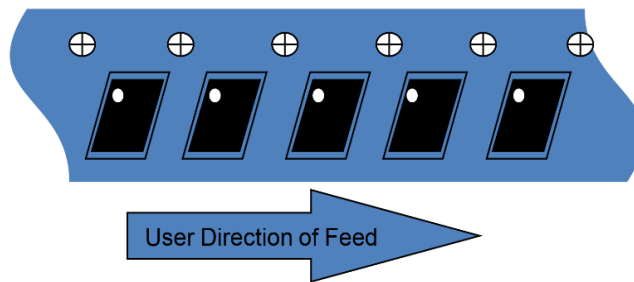

Tape and Reel Information – Reel Dimensions

Tape and reel specifications for this part are also available on the Qorvo website.
 Standard T/R size = 2,500 pieces on a 7" reel.

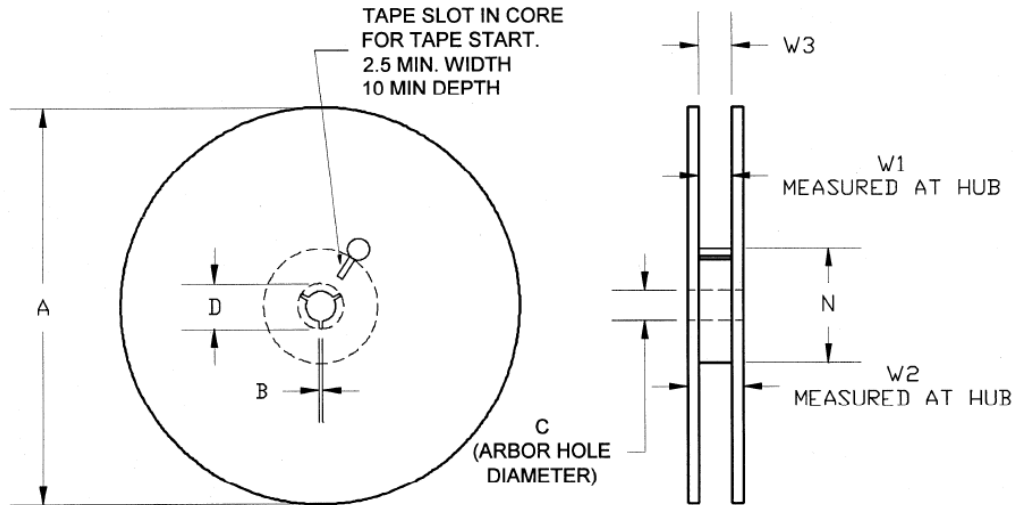

Feature	Measure	Symbol	Size (in)	Size (mm)
Flange	Diameter	A	6.969	177.0
	Thickness	W2	0.559	14.2
	Space Between Flange	W1	0.346	8.8
Hub	Outer Diameter	N	2.283	58.0
	Arbor Hole Diameter	C	0.512	13.0
	Key Slit Width	B	0.079	2.0
	Key Slit Diameter	D	0.787	20.0

Handling Precautions

Parameter	Rating	Standard
ESD – Human Body Model (HBM)	Class 1C	ESDA / JEDEC JS-001-2012
ESD – Charged Device Model (CDM)	Class C3	ESDA / JEDEC JS-002-2014
MSL – Moisture Sensitivity Level	Level 3	IPC/JEDEC J-STD-020



Caution!
ESD-Sensitive Device

Solderability

Compatible with both lead-free (260°C max. reflow temp.) and tin/lead (245°C max. reflow temp.) soldering processes. Solder profiles available upon request.

Contact plating: NiAu (*Plating thickness: Ni 5.0 ± 3.0 μm; Au 0.10 μm min.*)

RoHS Compliance

This part is compliant with 2011/65/EU RoHS directive (Restrictions on the Use of Certain Hazardous Substances in Electrical and Electronic Equipment) as amended by Directive 2015/863/EU.

This product also has the following attributes:

- Lead Free
- Halogen Free (Chlorine, Bromine)
- Antimony Free
- TBBP-A (C₁₅H₁₂Br₄O₂) Free
- PFOS Free
- SVHC Free



Contact Information

For the latest specifications, additional product information, worldwide sales and distribution locations:

Web: www.qorvo.com

Tel: 1-844-890-8163

Email: customer.support@qorvo.com

For technical questions and application information:

Email: appsupport@qorvo.com

Important Notice

The information contained herein is believed to be reliable; however, Qorvo makes no warranties regarding the information contained herein and assumes no responsibility or liability whatsoever for the use of the information contained herein. All information contained herein is subject to change without notice. Customers should obtain and verify the latest relevant information before placing orders for Qorvo products. The information contained herein or any use of such information does not grant, explicitly or implicitly, to any party any patent rights, licenses, or any other intellectual property rights, whether with regard to such information itself or anything described by such information. **THIS INFORMATION DOES NOT CONSTITUTE A WARRANTY WITH RESPECT TO THE PRODUCTS DESCRIBED HEREIN, AND QORVO HEREBY DISCLAIMS ANY AND ALL WARRANTIES WITH RESPECT TO SUCH PRODUCTS WHETHER EXPRESS OR IMPLIED BY LAW, COURSE OF DEALING, COURSE OF PERFORMANCE, USAGE OF TRADE OR OTHERWISE, INCLUDING THE IMPLIED WARRANTIES OF MERCHANTABILITY AND FITNESS FOR A PARTICULAR PURPOSE.**

Without limiting the generality of the foregoing, Qorvo products are not warranted or authorized for use as critical components in medical, life-saving, or life-sustaining applications, or other applications where a failure would reasonably be expected to cause severe personal injury or death.

Copyright 2018 © Qorvo, Inc. | Qorvo is a registered trademark of Qorvo, Inc.

X-ON Electronics

Largest Supplier of Electrical and Electronic Components

Click to view similar products for [RF Development Tools](#) category:

Click to view products by [Qorvo](#) manufacturer:

Other Similar products are found below :

[MAAM-011117](#) [MAAP-015036-DIEEV2](#) [EV1HMC1113LP5](#) [EV1HMC6146BLC5A](#) [EV1HMC637ALP5](#) [EVAL-ADG919EBZ](#) [ADL5363-EVALZ](#) [LMV228SDEVAL](#) [SKYA21001-EVB](#) [SMP1331-085-EVB](#) [EV1HMC618ALP3](#) [EVAL01-HMC1041LC4](#) [MAAL-011111-000SMB](#)
[MAAM-009633-001SMB](#) [MASW-000936-001SMB](#) [107712-HMC369LP3](#) [107780-HMC322ALP4](#) [SP000416870](#) [EV1HMC470ALP3](#)
[EV1HMC520ALC4](#) [EV1HMC244AG16](#) [MAX2614EVKIT#](#) [124694-HMC742ALP5](#) [SC20ASATEA-8GB-STD](#) [MAX2837EVKIT+](#)
[MAX2612EVKIT#](#) [MAX2692EVKIT#](#) [EV1HMC629ALP4E](#) [SKY12343-364LF-EVB](#) [108703-HMC452QS16G](#) [EV1HMC863ALC4](#)
[EV1HMC427ALP3E](#) [119197-HMC658LP2](#) [EV1HMC647ALP6](#) [ADL5725-EVALZ](#) [106815-HMC441LM1](#) [EV1HMC1018ALP4](#)
[UXN14M9PE](#) [MAX2016EVKIT](#) [EV1HMC939ALP4](#) [MAX2410EVKIT](#) [MAX2204EVKIT+](#) [EV1HMC8073LP3D](#) [SIMSA868-DKL](#)
[SIMSA868C-DKL](#) [SKY65806-636EK1](#) [SKY68020-11EK1](#) [SKY67159-396EK1](#) [SKY66181-11-EK1](#) [SKY65804-696EK1](#)