

Product Description

The RFAM3620 is an Integrated Edge QAM Amplifier Module. The part employs GaAs pHEMT die, GaAs MESFET die, a 20 dB range variable attenuator and a power enable feature, has high output capability, and is operated from 45 MHz to 1218 MHz. It provides excellent linearity and superior return loss performance with low noise and optimal reliability.

Functional Block Diagram

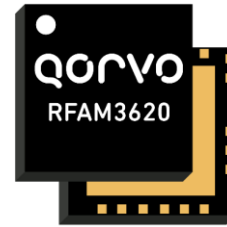
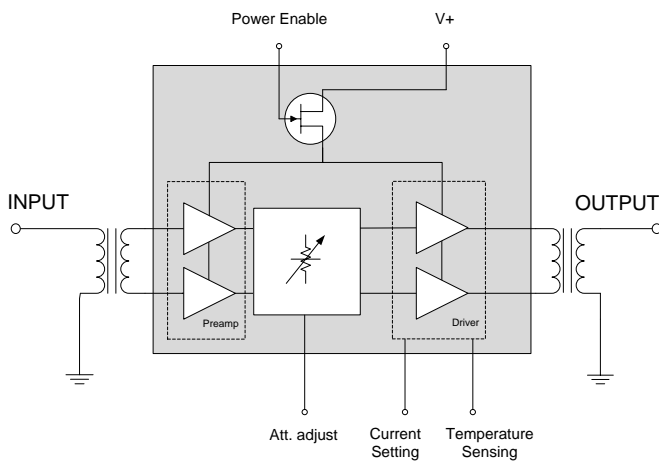

21 pin, 11.0 mm x 11.0 mm x 1.375 mm package

Product Features

- Excellent Linearity
- Extremely High Output Capability
- Voltage Controlled Attenuator
- Power Enable Feature
- Extremely Low Distortion
- Optimal Reliability
- Low Noise
- Unconditionally Stable Under all Terminations
- 36 dB Min Gain at 1218 MHz
- 510 mA Typical at 12 VDC
- Temperature sensing feature

Applications

- Head End Equipment
- 45 – 1218 MHz Downstream Edge QAM RF Modulators

Ordering Information

Part No.	Description
RFAM3620SB	Sample bag 5 pcs
RFAM3620SR	7" Reel with 100 pcs
RFAM3620TR7	7" Reel with 250 pcs
RFAM3620PCBA-410	Fully assembled Evaluation Board

Absolute Maximum Ratings

Parameter	Value / Range
DC Supply over-voltage (5 minutes)	+14 V
Storage Temperature	-40 to 100 °C
Operating Mounting Base Temperature	-30 to 110 °C
Moisture Sensitivity Level IPC/JEDEC J-STD-20	MSL 3 @ 260 °C

Operation of this device outside the parameter ranges given above may cause permanent damage.

Electrical Specifications – part 1

Parameter	Conditions (V+=12V, TMB=30°C, ZS=ZL=75Ω, ATT=0dB)	Min	Typ	Max	Units
Operational Frequency Range	–	45	–	1218	MHz
Current (I _{DD})	–		510	550	mA
Gain	f _o = 45 MHz		35.5		dB
Gain	f _o = 1218 MHz	36.0	37.0	38.0	
Gain Slope	45 to 1218 MHz ^[1]	0.5	1.0	2.5	
Gain Flatness	45 to 1218 MHz		0.5	1.0	
Input Return Loss	f _o = 45 to 160 MHz	18		–	dB
	f _o = 160 to 1003 MHz	15		–	
	f _o = 1003 to 1218 MHz	15		–	
Output Return Loss	f _o = 45 to 160 MHz	18		–	dB
	f _o = 160 to 1003 MHz	15		–	
	f _o = 1003 to 1218 MHz	15		–	
Noise Figure	f _o = 50 to 1218 MHz	–	3.0	5.0	dB
Attenuator Range	Attenuator Voltage 0V to 12V	0 - 20			dB
Power Enable/Disable	Logic high (3.3V) applied to power enable pin ^[2]		Amp enabled		
Power Enable/Disable	Logic low (0V) applied to power enable pin ^[3]		Amp disabled		
Thermal Resistance	Junction to Mounting Base		6.5		K/W

Electrical Specifications – part 2

Parameter	Conditions (V+=12V, TMB=30°C, ZS=ZL=75Ω, ATT=0dB)	Min	Typ	Max	Units
Adjacent Channel Power Ratio (ACPR); N=4 contiguous 256QAM channels	Channel Power = 58 dBmV; Adjacent channel up to 750 kHz from channel block edge, f= 50 to 1000 MHz			-58	dBc
	Channel Power = 58 dBmV; Adjacent channel (750 kHz from channel block edge to 6 MHz from channel block edge), f= 50 to 1000 MHz			-60	dBc
	Channel Power = 58 dBmV; Next-adjacent channel (6 MHz from channel block edge to 12 MHz from channel block edge), f= 50 to 1000 MHz			-63	dBc
	Channel Power = 58 dBmV; Third-adjacent channel (12 MHz from channel block edge to 18 MHz from channel block edge), f= 50 to 1000 MHz			-65	dBc
2 nd Order Harmonic (HD2); N=1 256QAM channel	Channel Power = 66 dBmV; In each of 2N contiguous 6 MHz channels coinciding with 2nd harmonic components (up to 1000MHz)			-63	dBc
3 rd Order Harmonic (HD3); N=1 256QAM channel	Channel Power = 66 dBmV; In each of 3N contiguous 6 MHz channels coinciding with 3rd harmonic components (up to 1000MHz)			-63	dBc
CTB	Vo=48 dBmV, flat, 79 analog channels plus 75 digital channels (-6dB offset) ^[4]		-73		dBc
XMOD			-70		dBc
CSO			-75		dBc
CIN			64		dB

1. The slope is defined as the difference between the gain at the start frequency and the gain at the stop frequency.
2. Logic high is defined as power enable voltage >2V
3. Logic low is defined as power enable voltage <0.4V
4. 79 analog channels, NTSC frequency raster: 55.25MHz to 547.25MHz, +48dBmV flat output level, plus 75 digital channels, -6dB offset relative to the equivalent analog carrier.

Composite Second Order (CSO) - The CSO parameter (both sum and difference products) is defined by ANSI/SCTE 6. Composite Triple Beat (CTB) The CTB parameter is defined by ANSI/SCTE 6. Cross Modulation (XMOD) - Cross modulation (XMOD) is measured at baseband (selective voltmeter method), referenced to 100% modulation of the carrier being tested. Carrier to Intermodulation Noise (CIN) - The CIN parameter is defined by ANSI/SCTE 17 (Test procedure for carrier to noise).

Evaluation Board Assembly Drawing

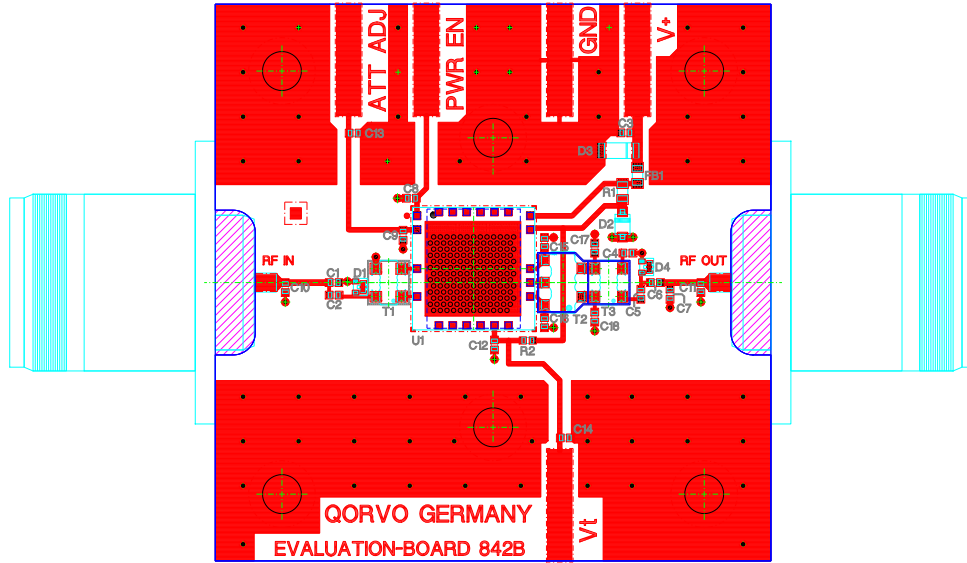

Note:
 Vias are required under the backside paddle of this device for proper RF/DC grounding and thermal dissipation. A via drill diameter of 0.4mm and a minimum via wall copper plating thickness of 25um is recommended. Open vias are preferred to allow flux and gases to escape during reflow soldering and therefore to minimize voiding. Underneath this via array a heat sink with thermal grease needs to be placed which is able to dissipate the complete module DC power (up to 6.1 Watts). In any case the module backside temperature should not exceed 100 °C.

Evaluation Board Schematic

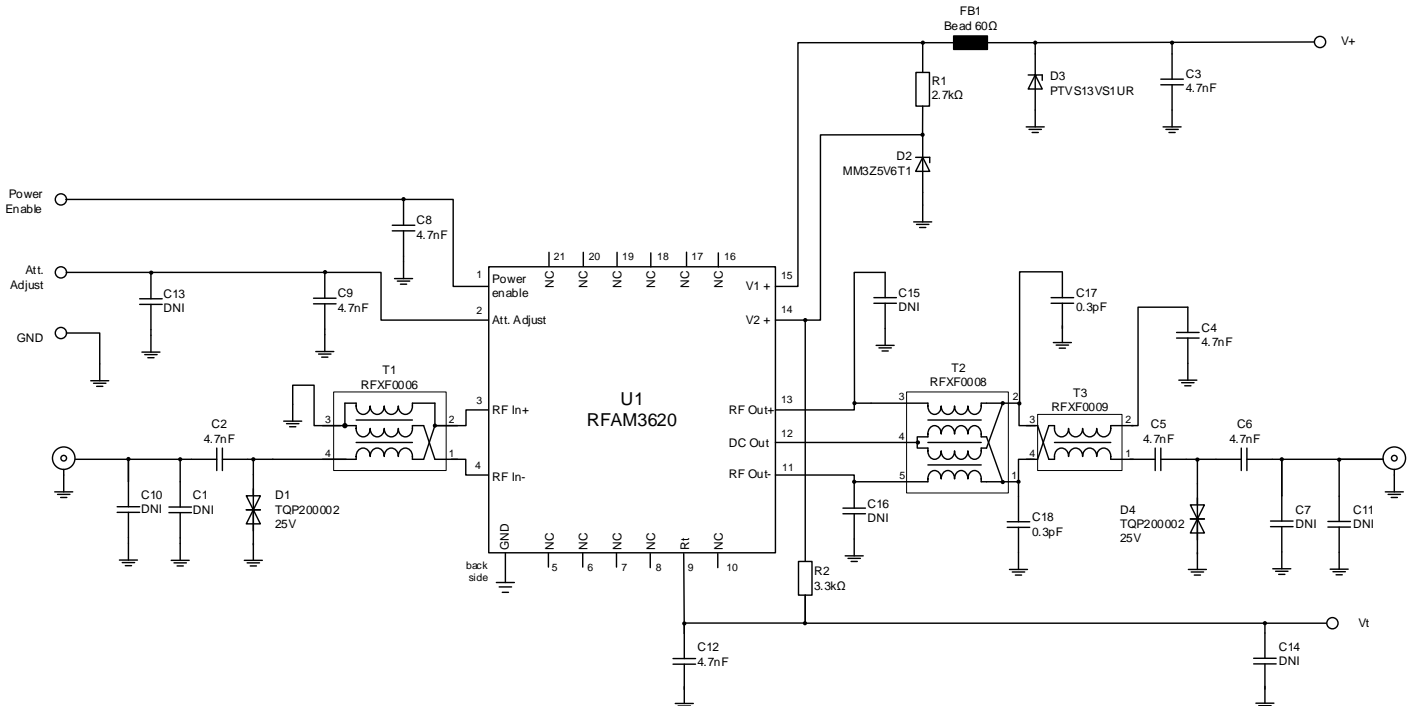

Evaluation Board Bill of Materials (BOM)

Reference Des.	Value	Description	Manuf.	Part Number
PCB	Rev B	PCB RFAM3620 – EVB 842B	Qorvo	
C1, C7, C10, C11, C15, C16	DNI	optional to improve matching in application		
C2, C3, C4, C5, C6, C8, C9, C12	4.7 nF	CAP, 0402, 10%, 50V, X7R		
C13, C14	DNI	optional blocking CAP		
C17, C18	0.3 pF	CAP, 0402, ± 0.1 pF, 50V, C0G		
R1	2.7 k Ω	RES, 0402, 1%, TK100		
R2	3.3 k Ω	RES, 0402, 1%, TK100		
FB1	60 Ω	Impedance Bead, 0603, 60 Ω @ 100MHz, LM, DCR 0.10 Ω , 800mA	TaiyoYuden	BK 1608 HS 600
D1, D4	25 V	ESD Protection Diode TQP200002, TSLP3	Qorvo/ Unisem	TQP200002
D2	5.6 V	Zener Diode MM3Z5V6T1G, SOD-323	ON Semi	MM3Z5V6T1G
D3	13 V	Diode, TVS, PTVS13VS1UR, SOD123W	NXP	PTVS13VS1UR
T1		RFXF0006	Qorvo	
T2		RFXF0008	Qorvo	
T3		RFXF0009	Qorvo	
U1	DUT	RFAM3620	Qorvo	

Notes:

Pin Configuration

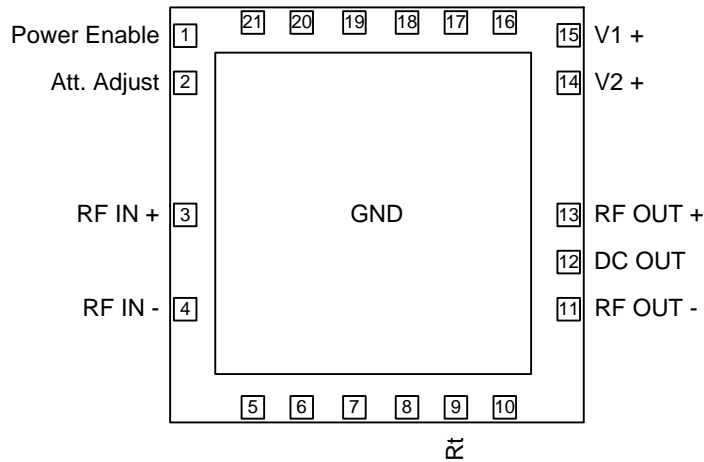

Pin Description

Pin No.	Label	Description
1	Power Enable	Logic Level (3.3V) Power Enable Control
2	Att. Adjust	Voltage Adjustable Attenuator
3	RF IN (+)	RF AMP Positive Input
4	RF IN (-)	RF AMP Negative Input
5 - 8	N.C.	
9	Rt	NTC Output for Temperature Sensing
10	N.C.	
11	RF OUT (-)	RF AMP Negative Output
12	DC Out	12V Output
13	RF OUT (+)	RF AMP Positive Output
14	V2 +	Supply Voltage 5.6V
15	V1 +	Supply Voltage 12V
16 - 21	N.C.	

RFAM3620 Temperature Sensing Feature

The RFAM3620 provides an internal NTC resistor for temperature sensing. This resistor is located right next to the output transistor stage. Within the application circuit the NTC is part of a voltage divider. The output voltage of the voltage divider (V_t) can be correlated to the module backside temperature.

Module Backside Temperature versus V_t (typical values)

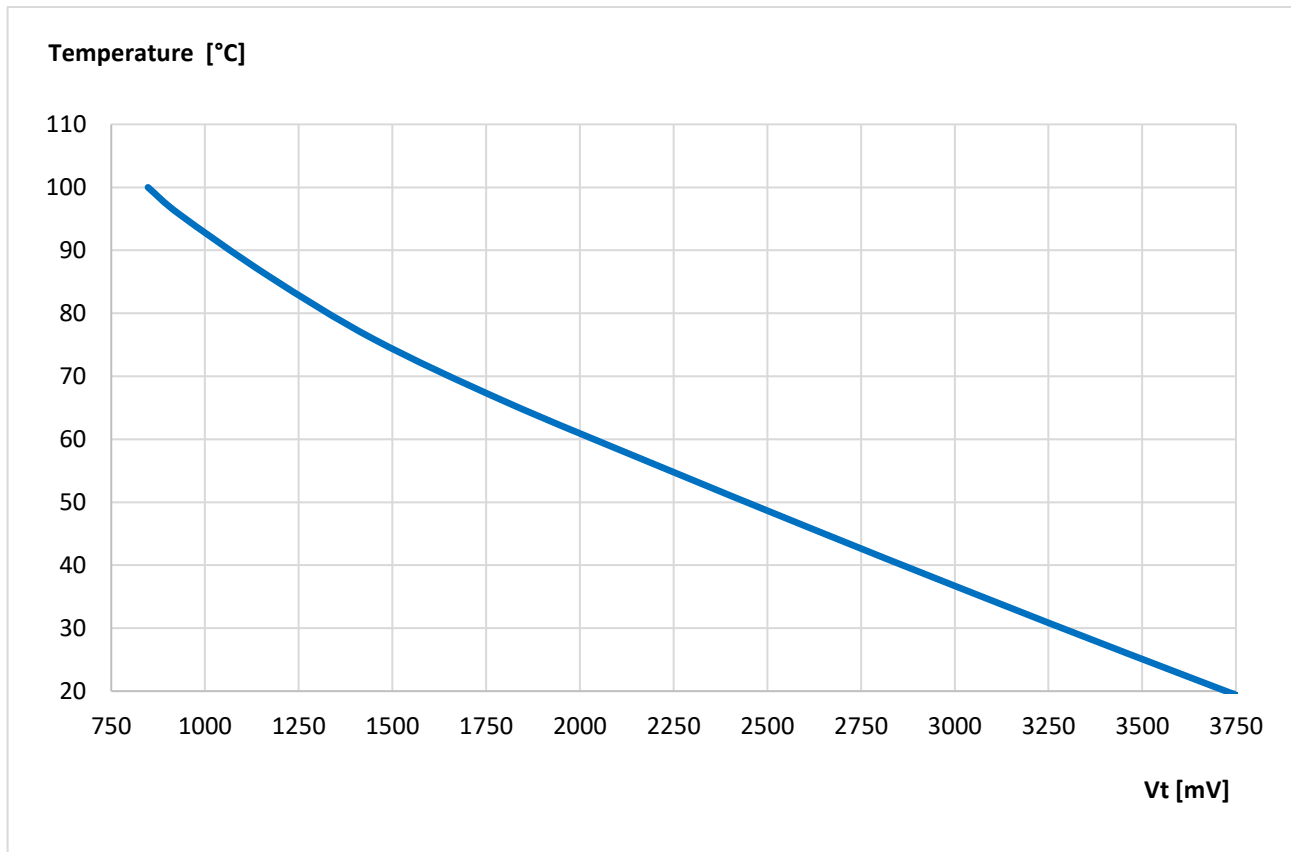

Package Outline Drawing (Dimensions in millimeters)

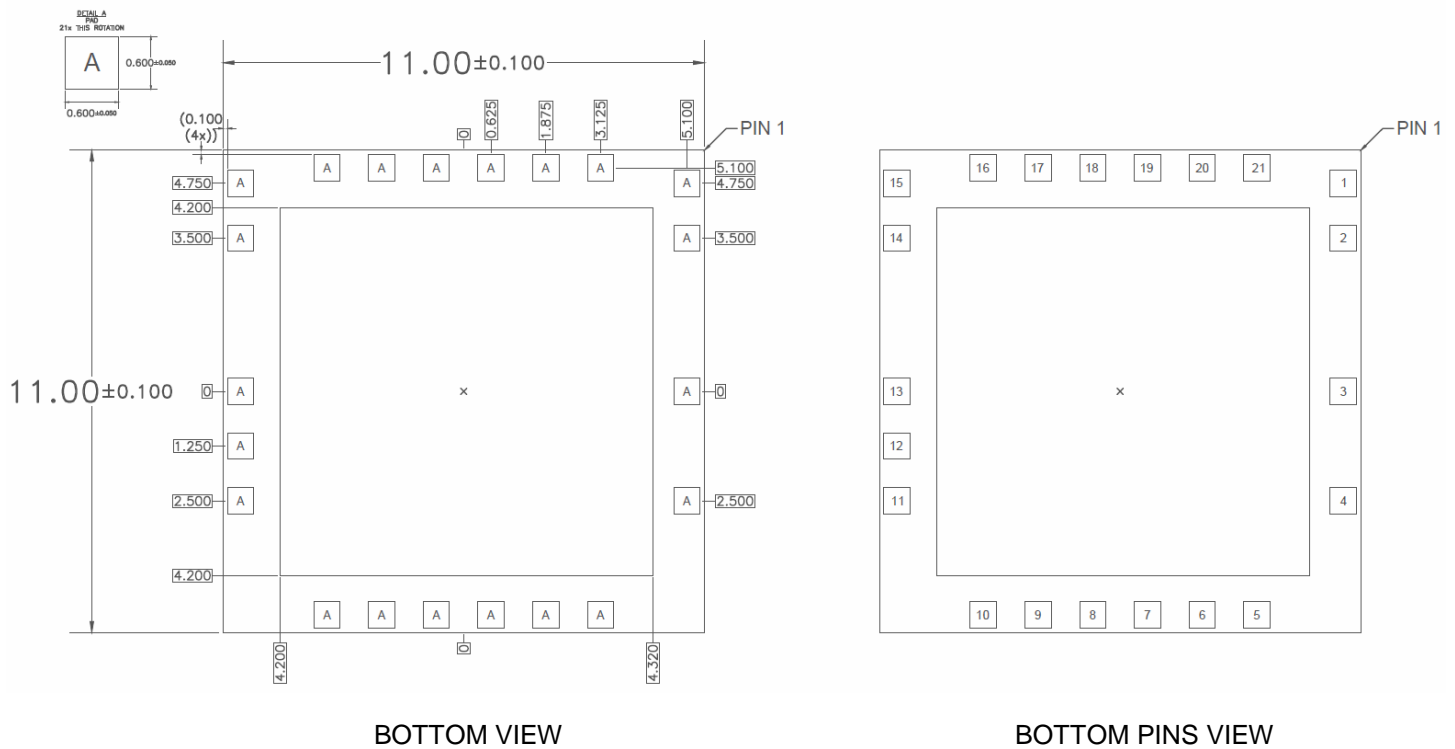
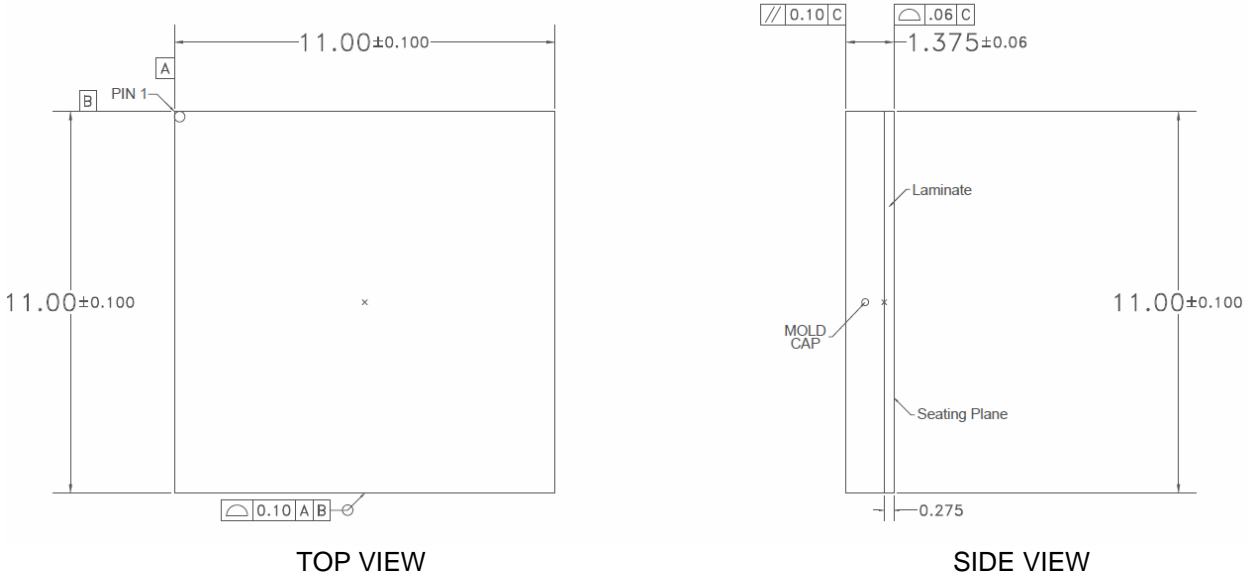

Notes:

1. Dimension and tolerance formats conform to ASME Y14.5M-1994.
2. The terminal #1 identifier and terminal numbering conform to JESD 95-1 SPP-012.
3. Co-planarity applies to the exposed ground/thermal pad as well as the contact pins.
4. Package body length/width does not include plastic flash protrusion across mold parting line.

PCB Metal Land Pattern (Dimensions in millimeters)

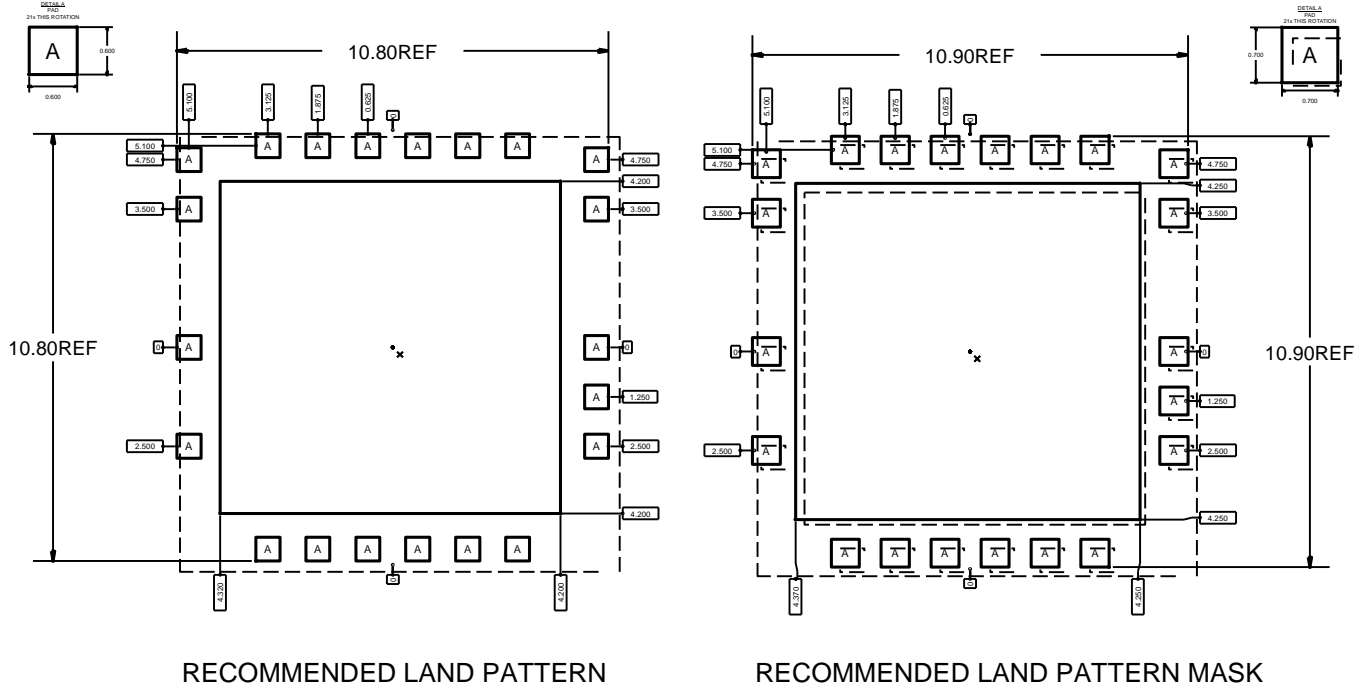

- Notes:
1. All dimensions are in millimeters. Angles are in degrees.
 2. Use 2 oz. copper minimum for top and bottom layer metal.
 3. Vias are required under the backside paddle of this device for proper RF/DC grounding and thermal dissipation. We recommend a 0.35mm (#80/.0135") diameter bit for drilling via holes and a final plated thru diameter of 0.25mm (0.10").
 4. Ensure good package backside paddle solder attach for reliable operation and best electrical performance.
 5. Place mounting screws near the part to fasten a back side heat sink.
 6. Do not apply solder mask to the back side of the PC board in the heat sink contact region.
 7. Ensure that the backside via region makes good physical contact with the heat sink.

Handling Precautions

Parameter	Rating	Standard
ESD – Human Body Model (HBM)	1B	ANSI/ESD/JEDEC JS-001-2012
ESD – Charged Device Model (CDM)	C3	JEDEC JESD22-C101F
MSL – Moisture Sensitivity Level	Level 3	IPC/JEDEC J-STD-020



Caution!
ESD-Sensitive Device

Solderability

Compatible with both lead-free (260°C max. reflow temp.) and tin/lead (245°C max. reflow temp.) soldering processes. Solder profiles available upon request.

Contact plating: NiPdAu

RoHS Compliance

This part is compliant with 2011/65/EU RoHS directive (Restrictions on the Use of Certain Hazardous Substances in Electrical and Electronic Equipment) as amended by Directive 2015/863/EU.

Contact Information

For the latest specifications, additional product information, worldwide sales and distribution locations:

Web: www.qorvo.com

Tel: 1-844-890-8163

Email: customer.support@qorvo.com

Important Notice

The information contained herein is believed to be reliable; however, Qorvo makes no warranties regarding the information contained herein and assumes no responsibility or liability whatsoever for the use of the information contained herein. All information contained herein is subject to change without notice. Customers should obtain and verify the latest relevant information before placing orders for Qorvo products. The information contained herein or any use of such information does not grant, explicitly or implicitly, to any party any patent rights, licenses, or any other intellectual property rights, whether with regard to such information itself or anything described by such information. **THIS INFORMATION DOES NOT CONSTITUTE A WARRANTY WITH RESPECT TO THE PRODUCTS DESCRIBED HEREIN, AND QORVO HEREBY DISCLAIMS ANY AND ALL WARRANTIES WITH RESPECT TO SUCH PRODUCTS WHETHER EXPRESS OR IMPLIED BY LAW, COURSE OF DEALING, COURSE OF PERFORMANCE, USAGE OF TRADE OR OTHERWISE, INCLUDING THE IMPLIED WARRANTIES OF MERCHANTABILITY AND FITNESS FOR A PARTICULAR PURPOSE.**

Without limiting the generality of the foregoing, Qorvo products are not warranted or authorized for use as critical components in medical, life-saving, or life-sustaining applications, or other applications where a failure would reasonably be expected to cause severe personal injury or death.

Copyright 2016 © Qorvo, Inc. | Qorvo is a registered trademark of Qorvo, Inc.

X-ON Electronics

Largest Supplier of Electrical and Electronic Components

Click to view similar products for [RF Development Tools](#) category:

Click to view products by [Qorvo](#) manufacturer:

Other Similar products are found below :

[MAAM-011117](#) [MAAP-015036-DIEEV2](#) [EV1HMC1113LP5](#) [EV1HMC6146BLC5A](#) [EV1HMC637ALP5](#) [EVAL-ADG919EBZ](#) [ADL5363-EVALZ](#) [LMV228SDEVAL](#) [SKYA21001-EVB](#) [SMP1331-085-EVB](#) [EV1HMC618ALP3](#) [EVAL01-HMC1041LC4](#) [MAAL-011111-000SMB](#) [MAAM-009633-001SMB](#) [MASW-000936-001SMB](#) [107712-HMC369LP3](#) [107780-HMC322ALP4](#) [SP000416870](#) [EV1HMC470ALP3](#) [EV1HMC520ALC4](#) [EV1HMC244AG16](#) [MAX2614EVKIT#](#) [124694-HMC742ALP5](#) [SC20ASATEA-8GB-STD](#) [MAX2837EVKIT+](#) [MAX2612EVKIT#](#) [MAX2692EVKIT#](#) [EV1HMC629ALP4E](#) [SKY12343-364LF-EVB](#) [108703-HMC452QS16G](#) [EV1HMC863ALC4](#) [EV1HMC427ALP3E](#) [119197-HMC658LP2](#) [EV1HMC647ALP6](#) [ADL5725-EVALZ](#) [MAX2371EVKIT#](#) [106815-HMC441LM1](#) [EV1HMC1018ALP4](#) [UXN14M9PE](#) [MAX2016EVKIT](#) [EV1HMC939ALP4](#) [MAX2410EVKIT](#) [MAX2204EVKIT+](#) [EV1HMC8073LP3D](#) [SIMSA868-DKL](#) [SIMSA868C-DKL](#) [SKY65806-636EK1](#) [SKY68020-11EK1](#) [SKY67159-396EK1](#) [SKY66181-11-EK1](#)