

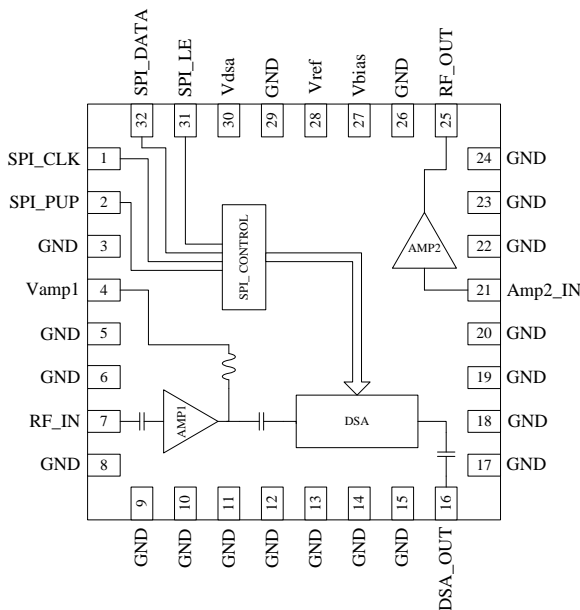

Features

- Frequency Range 400MHz to 2700MHz
- 6-Bit Digital Step Attenuator
- SPI Serial Control Programming
- Max Gain = 29.5dB Typical at 2140MHz
- Gain Control Range = 31.5dB (0.5dB Step Size)
- OIP3/P1dB = +44/25dBm Typical at 2140MHz
- Single +5V Supply
- Small 32-Pin, 5.2mm x 5.2mm, MCM
- Power-up Programming



Functional Block Diagram

Applications

- Cellular, 3G Infrastructure
- WiBro, WiMax, LTE
- Microwave Radio
- High Linearity Power Control

Product Description

RFMD's RFDA2125 is a digital controlled variable gain amplifier for broadband applications with external matching to allow for configurations in different bands with a single module. It features exceptional linearity with noise figure less than 5.0dB in its maximum gain state. The gain of the 6-bit digital step attenuator is programmed with a serial mode control interface (SPI). The RFDA2125 is packaged in a small 5.2mm x 5.2mm leadless laminate MCM, which contains plated through thermal vias for ultra-low thermal resistance.

Ordering Information

RFDA2125SR	7" Sample reel with 100 pieces
RFDA2125SQ	Sample bag with 25 pieces
RFDA2125TR13	13" Reel with 2500 pieces
RFDA2125PCK-410	400MHz to 2700MHz PCBA with 5-piece sample bag

RF MICRO DEVICES®, RFMD®, Optimum Technology Matching®, Enabling Wireless Connectivity™, PowerStar®, POLARIS™ TOTAL RADIO™ and d UltimateBlue™ are trademarks of RFMD, LLC. BLUETOOTH is a trademark owned by Bluetooth SIG, Inc., U.S.A. and licensed for use by RFMD. All other trade names, trademarks and registered trademarks are the property of their respective owners. ©2006, RF Micro Devices, Inc.

Absolute Maximum Ratings

Parameter	Rating	Unit
Supply Voltage	+5.5	V _{DC}
DC Supply Current	300	mA
Power Dissipation	1.6	W
Max RF Input Power for 50Ω Output Load	24	dBm
Operating Temperature (T _{CASE})	-40 to +85	°C
Storage Temperature	-40 to +150	°C
Junction Temperature	160	°C
ESD Rating (HBM)	1000 (Class 1C)	V
Moisture Sensitivity Level	MSL3	

Note: Operation of this device beyond any one of these limits may cause permanent damage. MTTF = 1E6 hours at 160 °C junction temperature.



Caution! ESD sensitive device.

Exceeding any one or a combination of the Absolute Maximum Rating conditions may cause permanent damage to the device. Extended application of Absolute Maximum Rating conditions to the device may reduce device reliability. Specified typical performance or functional operation of the device under Absolute Maximum Rating conditions is not implied.

RoHS status based on EUDirective2002/95/EC (at time of this document revision).

The information in this publication is believed to be accurate and reliable. However, no responsibility is assumed by RF Micro Devices, Inc. ("RFMD") for its use, nor for any infringement of patents, or other rights of third parties, resulting from its use. No license is granted by implication or otherwise under any patent or patent rights of RFMD. RFMD reserves the right to change component circuitry, recommended application circuitry and specifications at any time without prior notice.

Parameter	Specification			Unit	Condition
	Min.	Typ.	Max.		
Overall					Temperature=25 °C, V _{CC} = 5V, standard application circuit
Gain Control Range		31.5		dB	
Control Interface		6		bit	SPI interface
Setting Time		250		ns	T _{ON} , T _{OFF} (10%/90% RF)
Impedance		50		Ω	
Total Supply Voltage	4.75	5.0	5.25	V	
Total Supply Current		180		mA	
Thermal Resistance		60.8		°C/W	Junction to backside of device
Step Accuracy	+/- (0.2+5% attenuation setting)			dB	
728MHz to 746MHz					Temperature=25 °C, V _{CC} = 5V, standard application circuit
Max Gain		37		dB	
P1dB		26		dBm	Max gain
Output IP3		44		dBm	P _{OUT} =10dBm/tone, 1 MHz spacing, Max gain
ACPR		-67		dBc	WCDMA TM1 64DPCH 1C, Output power = 13dBm
Gain Flatness		0.1		dB	
Noise Figure		3.9		dB	Max gain
Input Return Loss		15		dB	
Output Return Loss		11		dB	

Parameter	Specification			Unit	Condition
	Min.	Typ.	Max.		
2110MHz to 2170MHz					Temperature=25 °C, V _{CC} = 5V, standard application circuit
Max Gain		29.5		dB	
P1dB		25		dBm	Max gain
Output IP3		44		dBm	P _{OUT} =10dBm/tone, 1 MHz spacing, Max gain
ACPR		-65		dBc	WCDMA TM1 64DPCH 1C, Output power = 13dBm
Gain Flatness		0.3		dB	
Noise Figure		4.4		dB	Max gain
Input Return Loss		15		dB	
Output Return Loss		17.5		dB	
2620MHz to 2690MHz					Temperature=25 °C, V _{CC} = V _{DD} = 5V, standard application circuit
Max Gain		28.5		dB	
P1dB		25		dBm	Max gain
Output IP3		44		dBm	P _{OUT} =10dBm/tone, 1 MHz spacing, Max gain
ACPR		-65		dBc	WCDMA TM1 64DPCH 1C, Output power = 13dBm
Gain Flatness		0.35		dB	
Noise Figure		4.5		dB	Max gain
Input Return Loss		20		dB	
Output Return Loss		15.5		dB	

Typical Performance: 728MHz to 746MHz Application Circuit

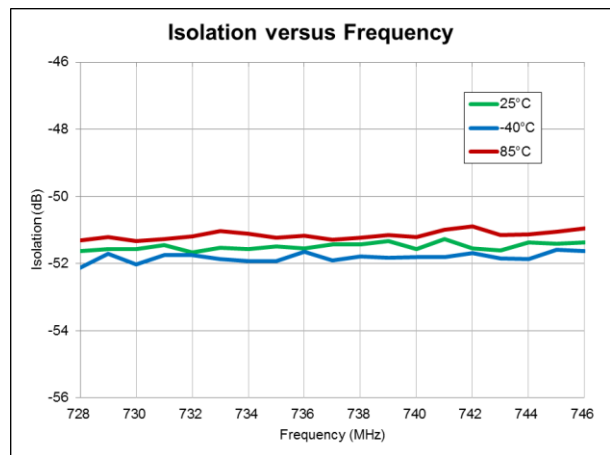
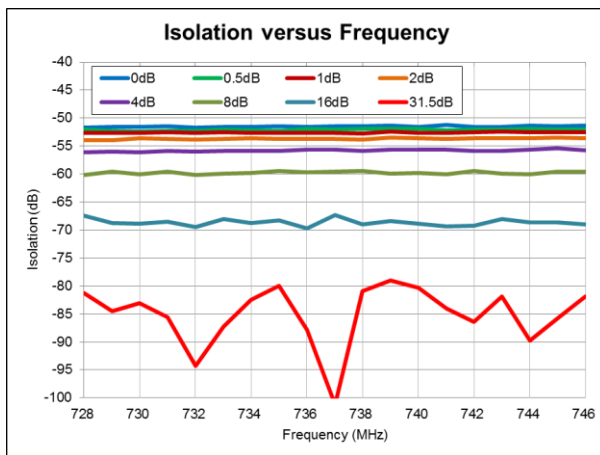
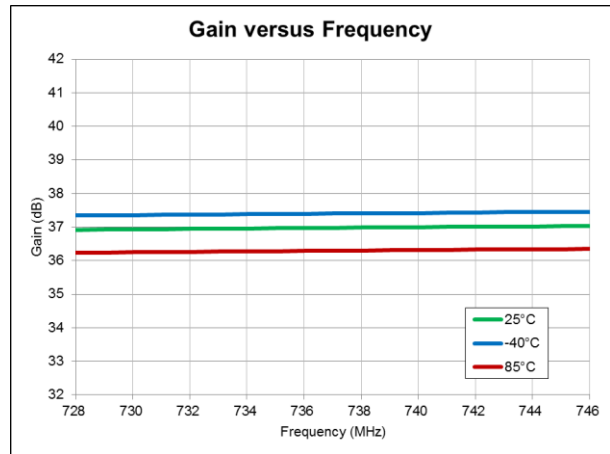
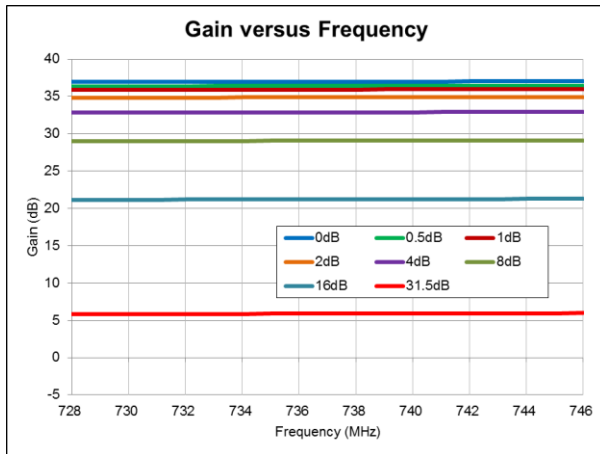
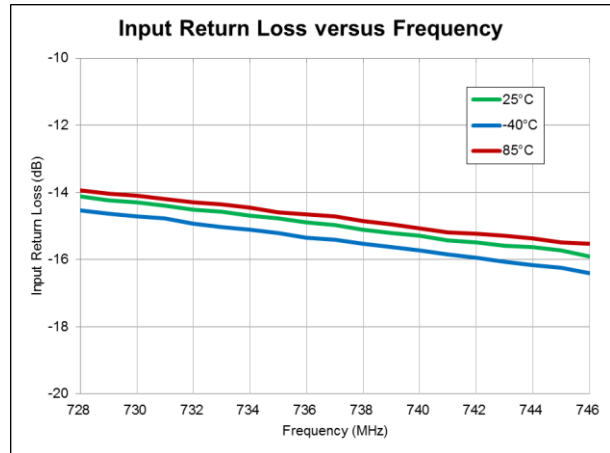
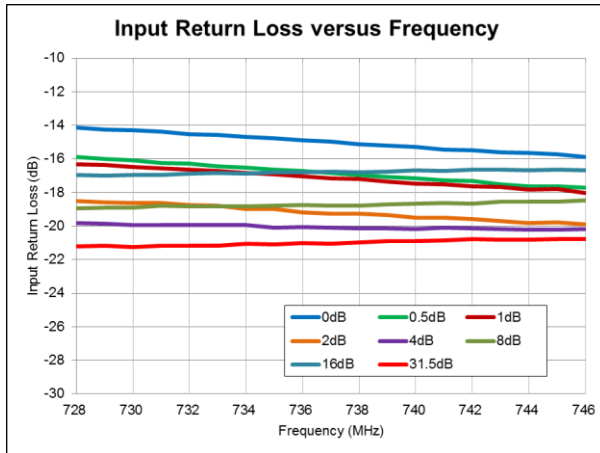

Typical Performance: 728MHz to 746MHz Application Circuit

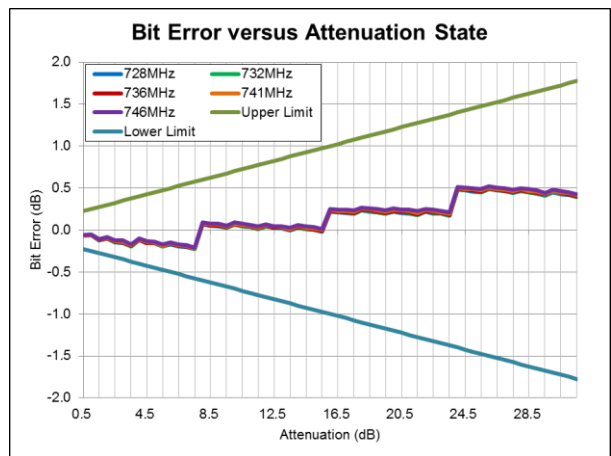
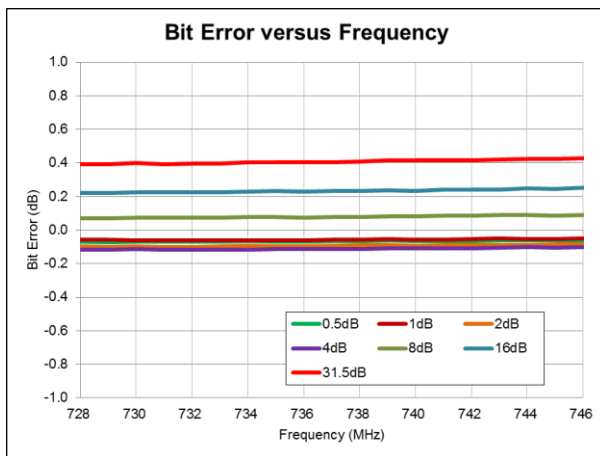
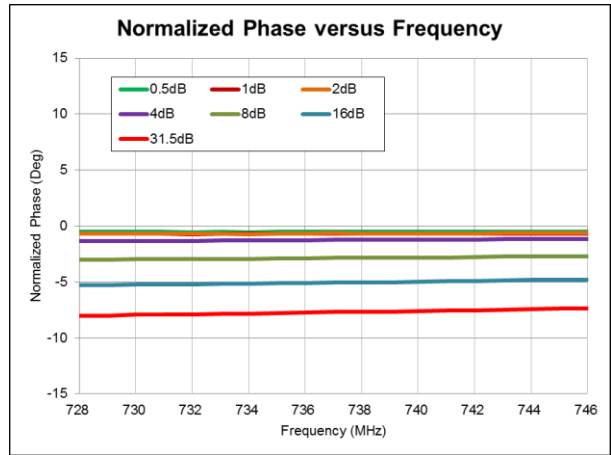
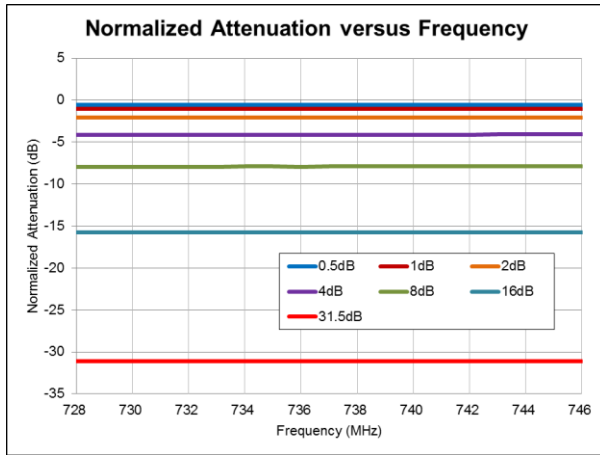
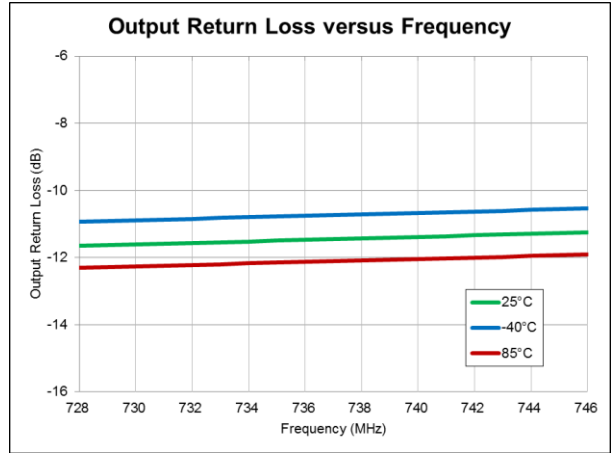
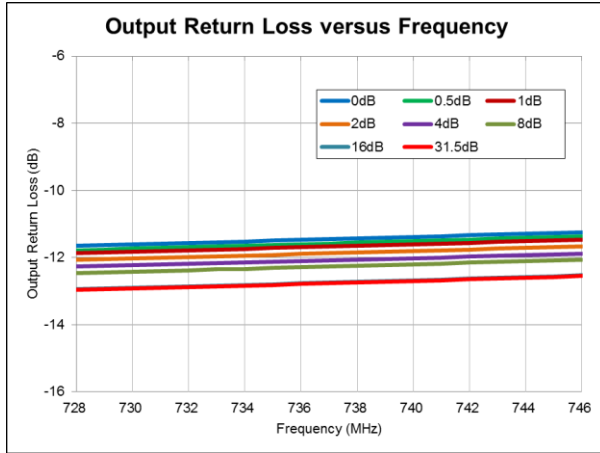

Typical Performance: 728MHz to 746MHz Application Circuit

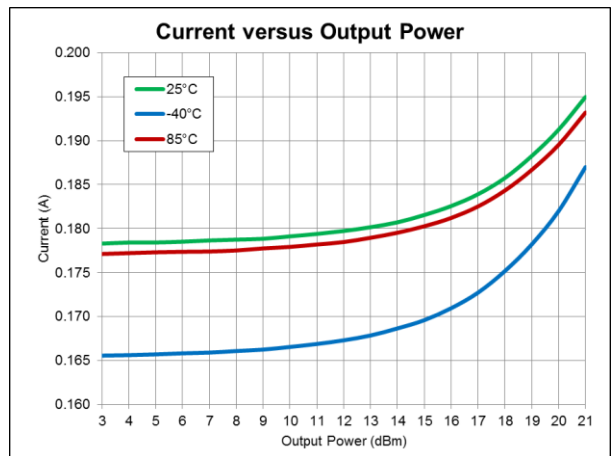
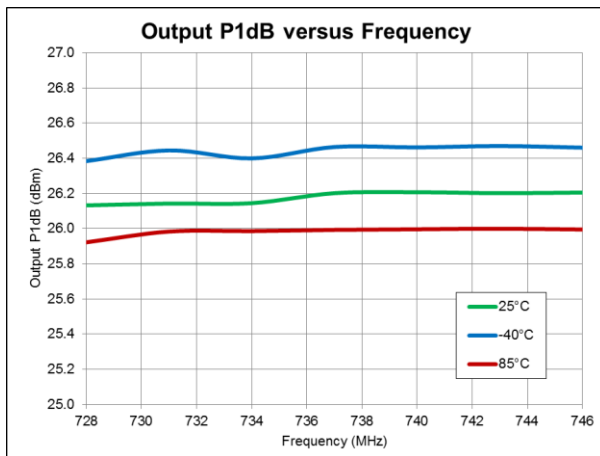
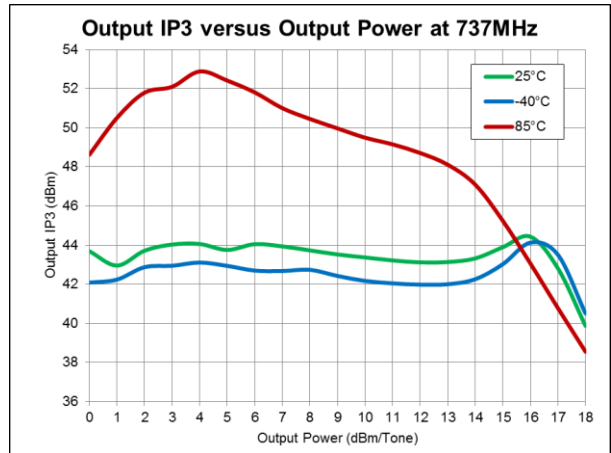
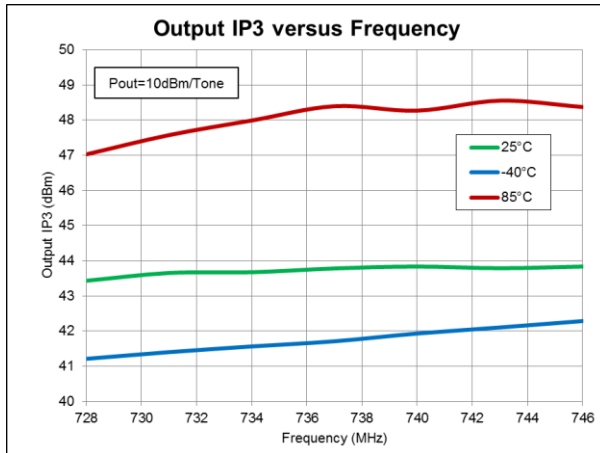
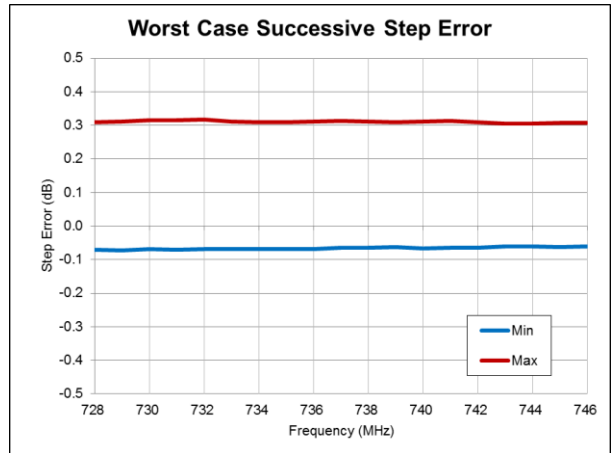
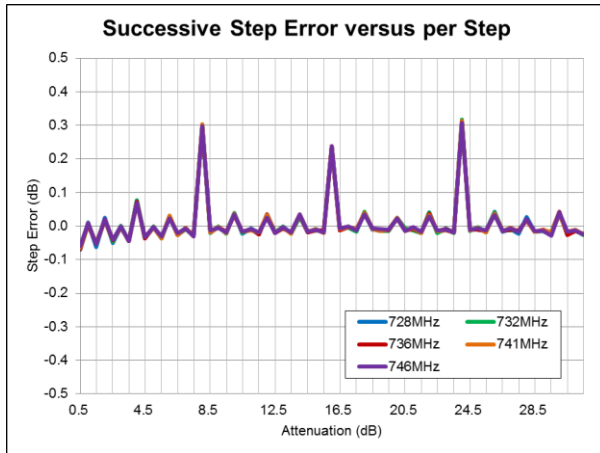

Typical Performance: 728MHz to 746MHz Application Circuit

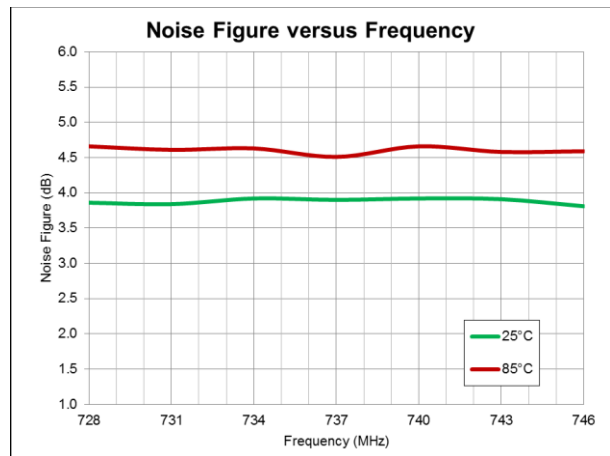
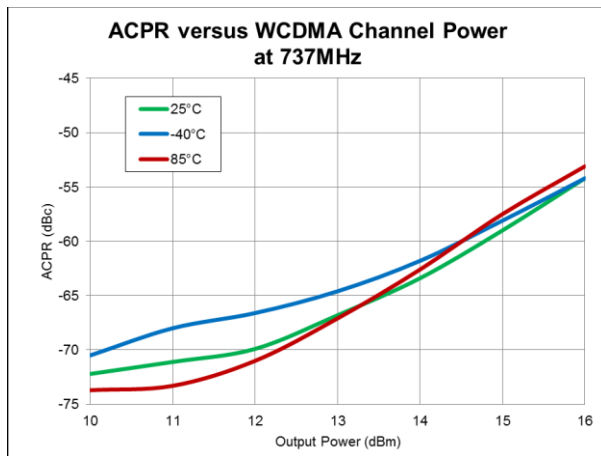

Evaluation Board Schematic 728MHz to 746MHz Application Circuit

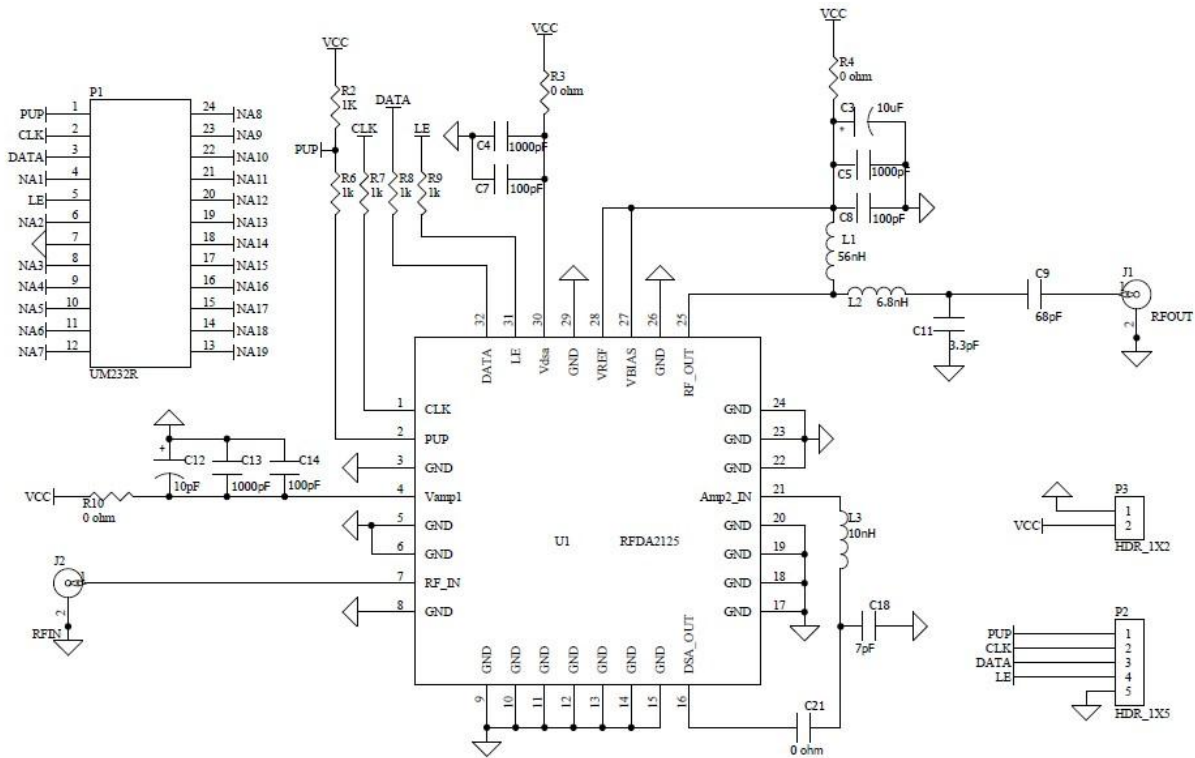

Evaluation Board Bill of Materials (BOM)

728MHz to 746MHz Application Circuit

Description	Reference Designator	Manufacturer	Manufacturer's P/N
Evaluation Board			RFDA2125410(A)
RFDA2125	U1	RFMD	RFDA2125
RES, 1K, 5%, 1/16W, 0603	R2, R6-R9	Panasonic Industrial Co.	ERJ-3GEYJ102
CAP, 100pF, 5%, 50V, C0G, 0402	C7-C8, C14	Murata Electronics	GRM1555C1H101JA01D
CAP, 1000pF, 10%, 50V, X7R, 0402	C4-C5, C13	Murata Electronics	GRM155R71H102KA01D
CAP, 10µF, 20%, 20V, TANT-B	C3, C12	Murata Electronics	TAJB106M020RNJ
CAP, 68pF, 5%, 50V, C0G, 0402	C9	Murata Electronics	GRM1555C1H680JZ01D
RES, 0Ω, 0402	C21	Kamaya, Inc.	RMC1/16SJPTH
CAP, 3.3pF, +/-0.1pF, 50V, C0G, 0402	C11	Murata Electronics	GRM1555C1H3R3BZ01E
CAP, 7.0pF, +/-0.25pF, 50V, C0G, 0402	C18	Murata Electronics	GRM1555C1H7R0CB01D
RES, 0Ω, 0603	R3-R4, R10	KOA Speer Electronics, Inc.	RK73Z1JLTD
IND, 6.8nH, 3%, T/F, HI-Q, 0201	L2	Murata Electronics	LQP03TN6N8H02D
IND, 10nH, 2%, W/W, 0402	L3	Murata Electronics	LQW15AN10NG00D
IND, 56nH, 5%, W/W, 0603	L1	Coilcraft, Inc.	0603CS-56NXJBC
CONN, SMA, END LNCH, FLT, 0.062"	J1-J2	Emerson Network Power	142-0701-821
CONN, HDR, ST, PLRZD, 2-PIN, 0.100"	P3	AMP	640454-2
CONN, HDR, ST, PLRZD, 5-PIN, 0.100"	P2	AMP	640454-5
DNP	P1		

Typical Performance: 2110MHz to 2170MHz Application Circuit

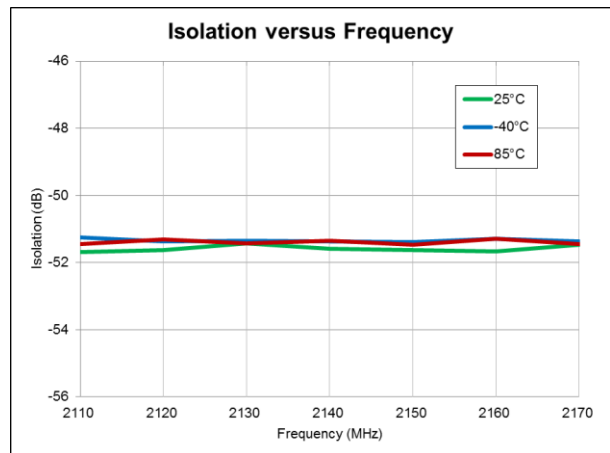
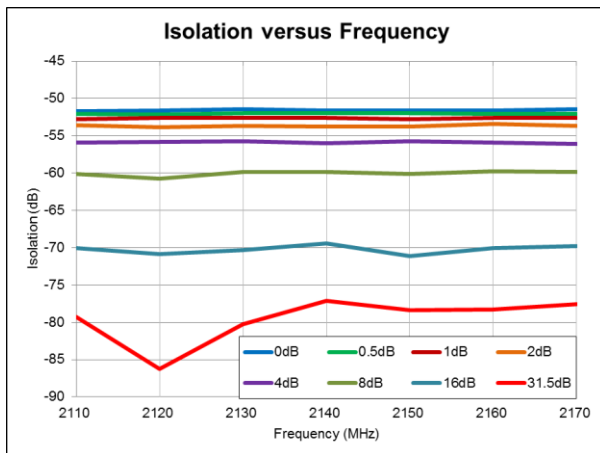
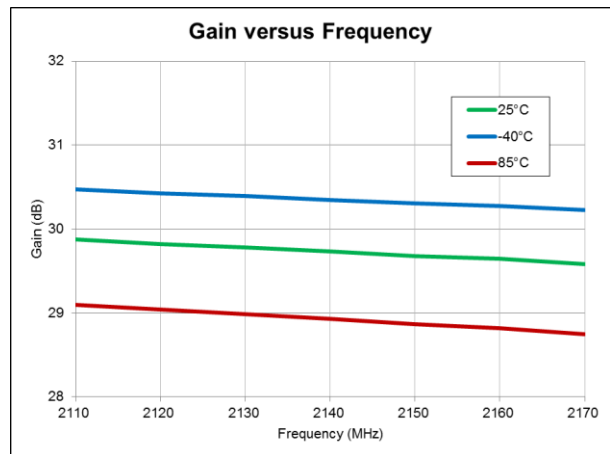
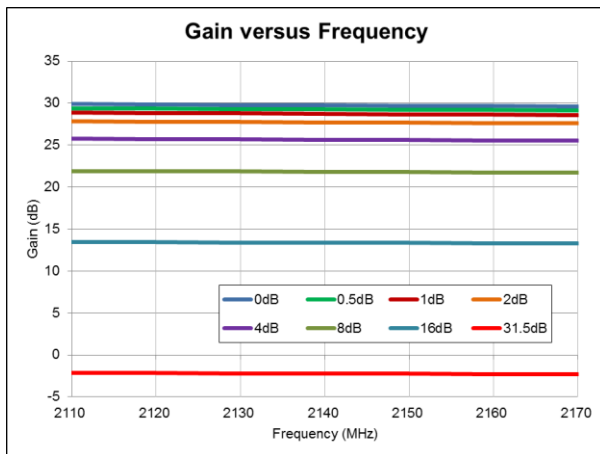
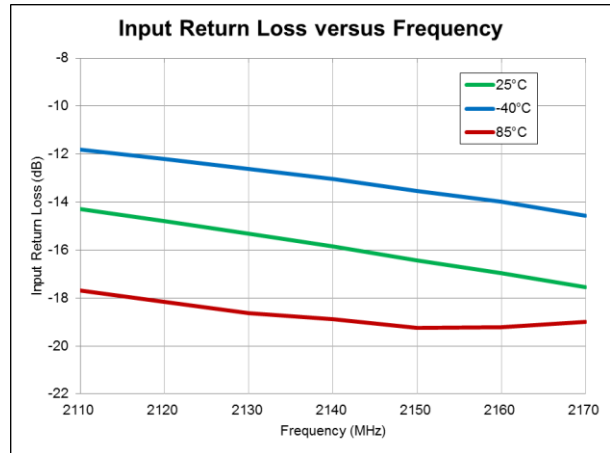
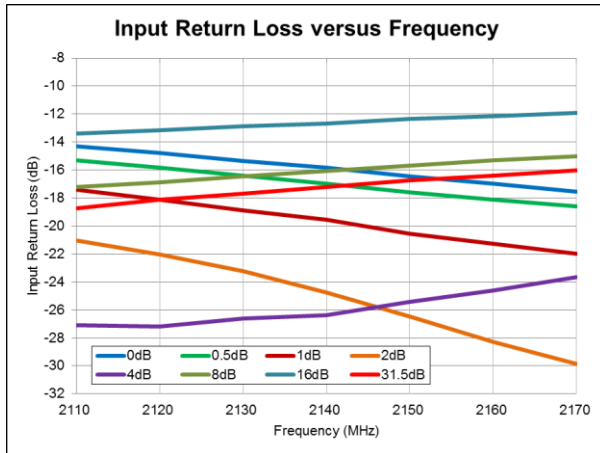

Typical Performance: 2110MHz to 2170MHz Application Circuit

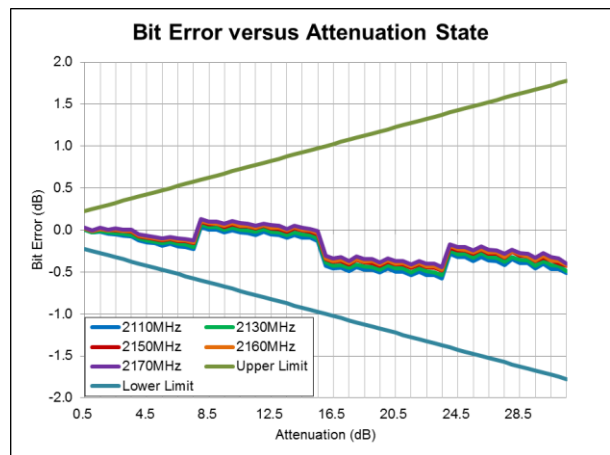
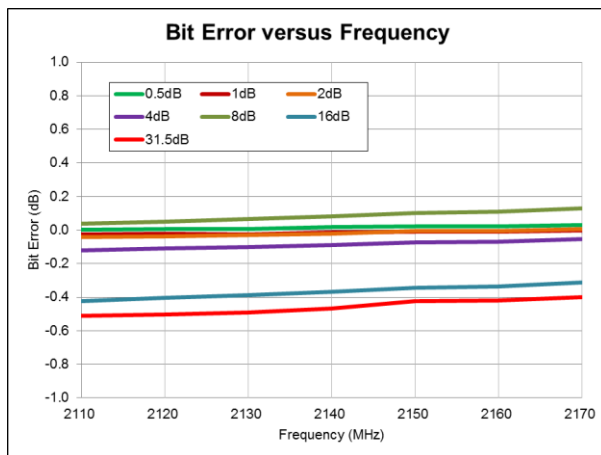
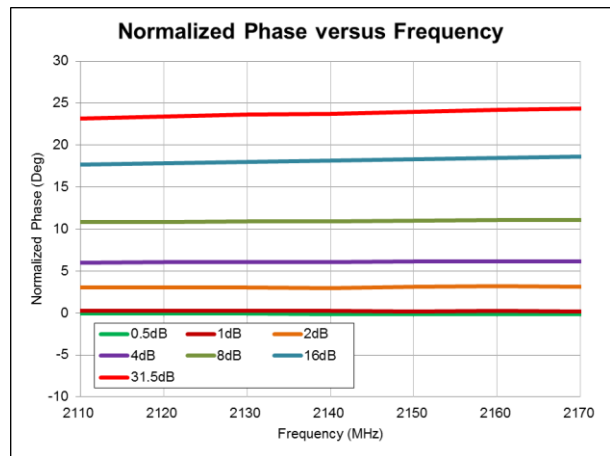
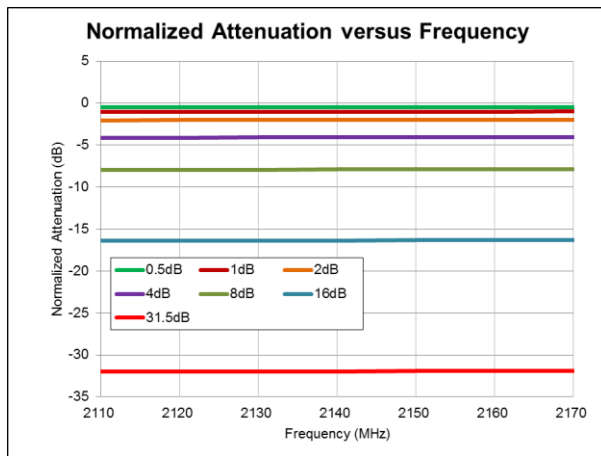
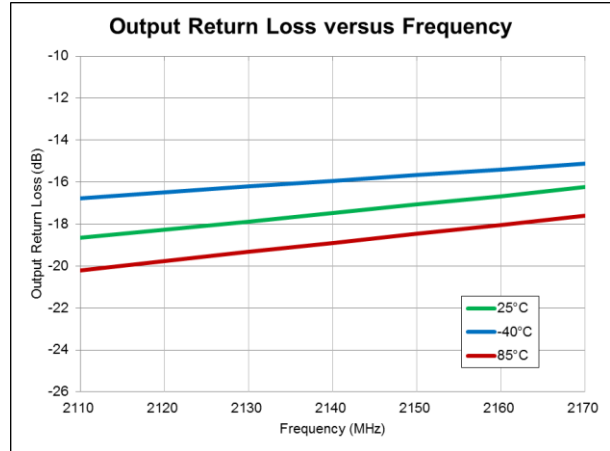
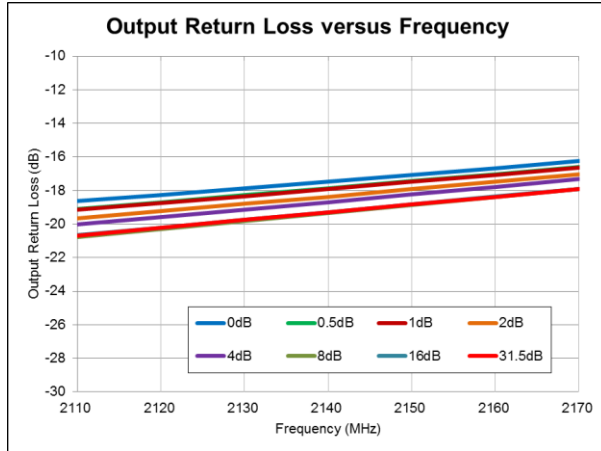

Typical Performance: 2110MHz to 2170MHz Application Circuit

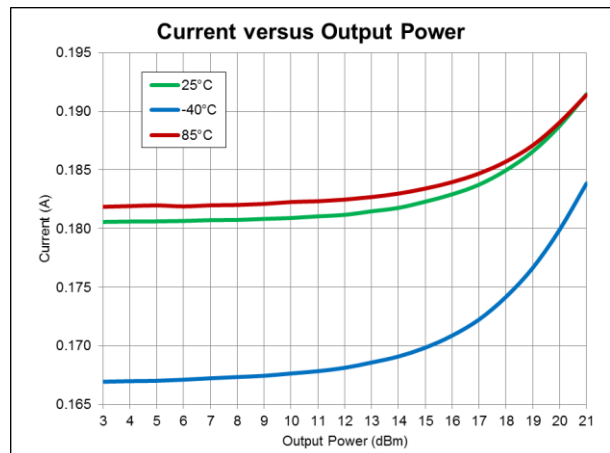
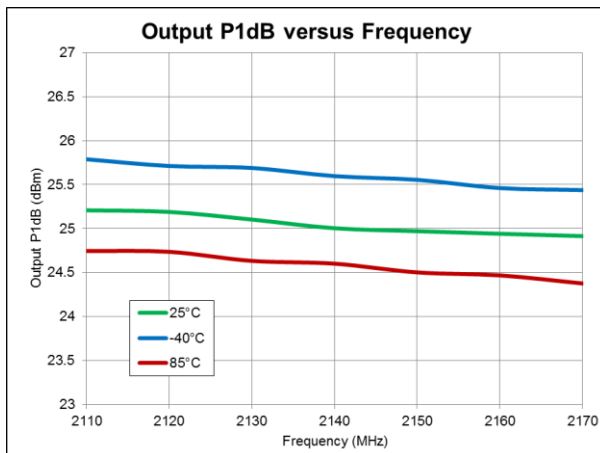
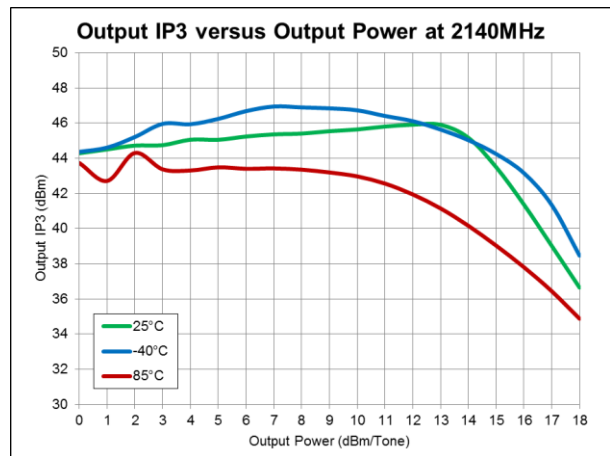
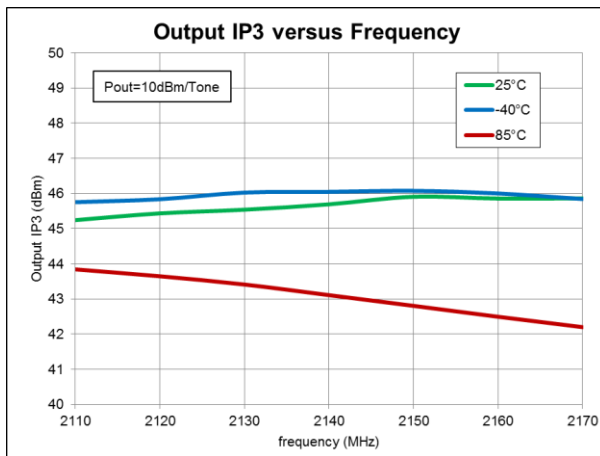
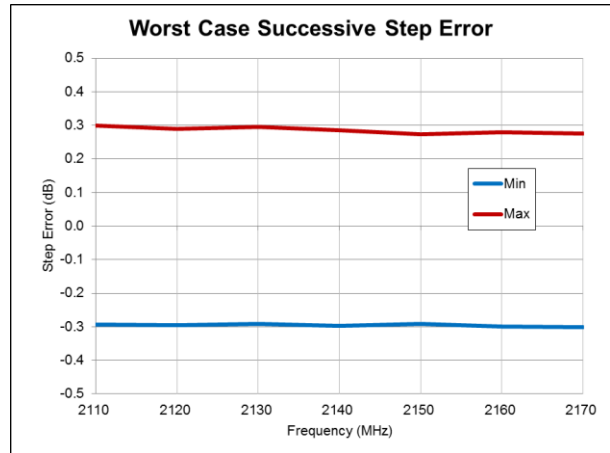

Typical Performance: 2110MHz to 2170MHz Application Circuit

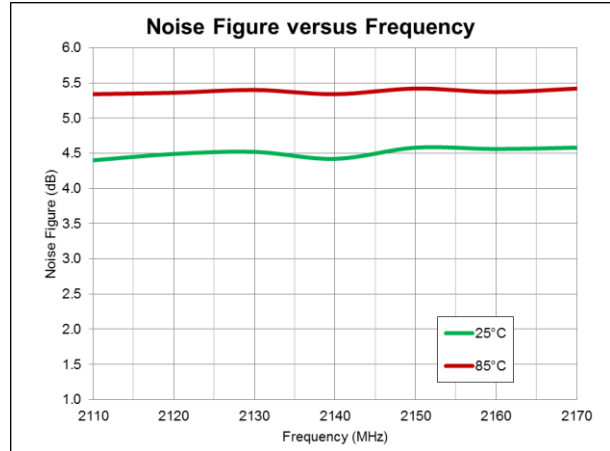
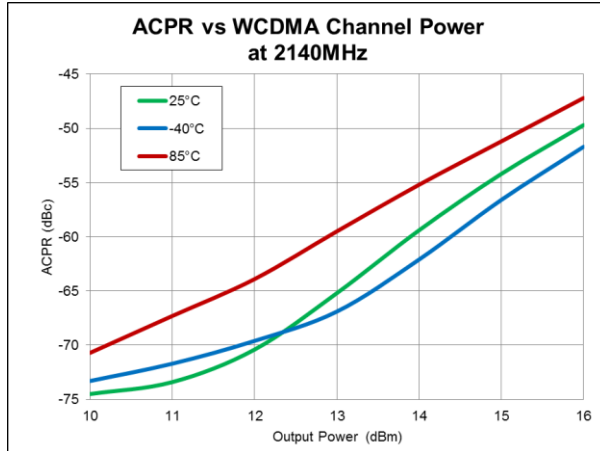

Evaluation Board Schematic 2110MHz to 2170MHz Application Circuit

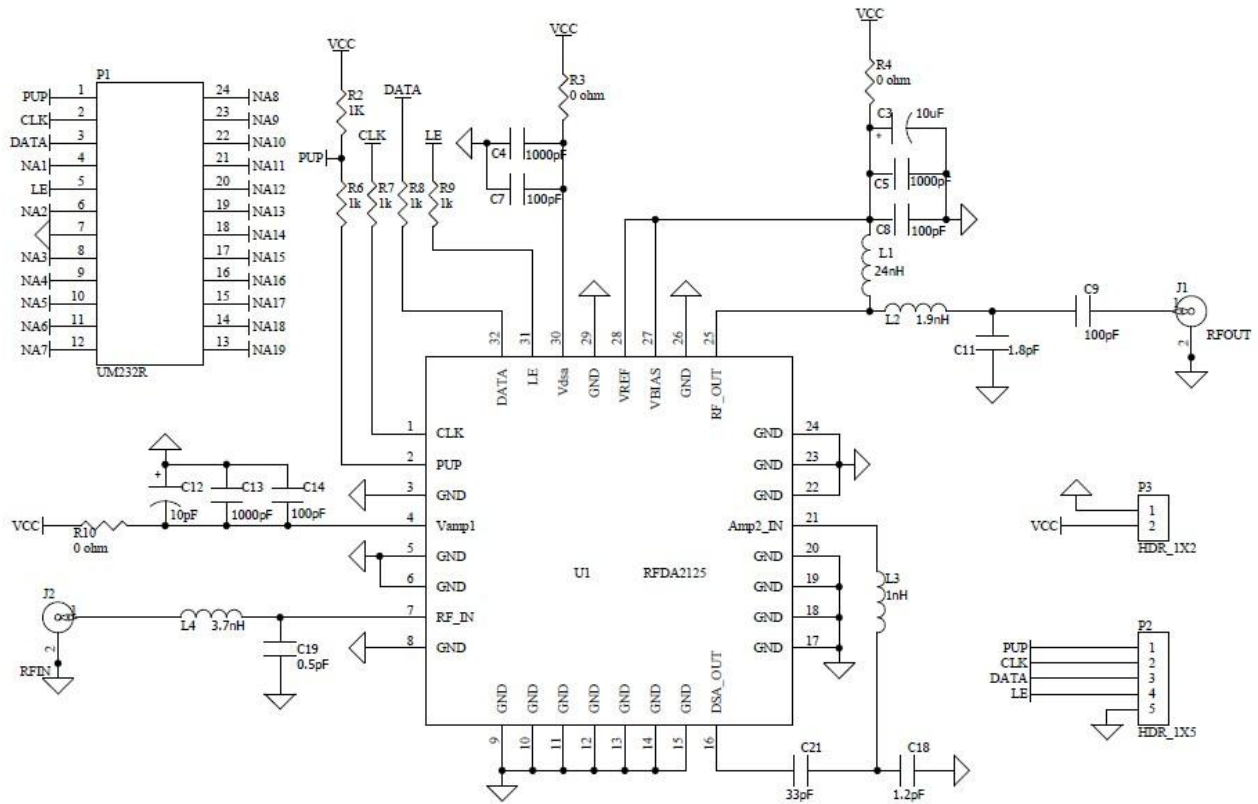

Evaluation Board Bill of Materials (BOM)

2110MHz to 2170MHz Application Circuit

Description	Reference Designator	Manufacturer	Manufacturer's P/N
Evaluation Board			RFDA2125410(A)
RFDA2125	U1	RFMD	RFDA2125
RES, 1K, 5%, 1/16W, 0603	R2, R6-R9	Panasonic Industrial Co.	ERJ-3GEYJ102
CAP, 100pF, 5%, 50V, COG, 0402	C7-C9, C14	Murata Electronics	GRM1555C1H101JA01D
CAP, 1000pF, 10%, 50V, X7R, 0402	C4-C5, C13	Murata Electronics	GRM155R71H102KA01D
CAP, 10µF, 20%, 20V, TANT-B	C3, C12	Murata Electronics	TAJB106M020RNJ
CAP, 0.5pF, +/-0.05pF, 50V, COG, 0402	C19	Murata Electronics	GJM1555C1HR50WB01D
CAP, 33pF, 5%, 50V, COG, 0402	C21	Murata Electronics	GRM1555C1H330JA01D
Cap, 1.8pF, +/-0.1pF, 50V, HI-Q, 0402	C11	Murata Electronics	GJM1555C1H1R8BB01D
1.2pF, 0.1pF, 50V, COG, 0402, LEAD FREE, HIGH Q	C18	Murata Electronics	GJM1555C1H1R2BB01D
RES, 0Ω, 0603	R3-R4, R10	KOA Speer Electronics, Inc.	RK73Z1JLTD
IND, 3.7nH, +/-0.1nH, T/F, HI-Q, 0201	L4	Murata Electronics	LQP03TN3N7B02D
IND, 1.9nH, +/-0.1nH, T/F, HI-Q, 0201	L2	Murata Electronics	LQP03TN1N9B02D
IND, 1.0nH, +/-0.1nH, T/F, HI-Q, 0201	L3	Murata Electronics	LQP03TN1N0B00
IND, 24nH, 5%, W/W, 0603	L1	Coilcraft, Inc.	0603CS-24NXJBC
CONN, SMA, END LNCH, FLT, 0.062"	J1-J2	Emerson Network Power	142-0701-821
CONN, HDR, ST, PLRZD, 2-PIN, 0.100"	P3	AMP	640454-2
CONN, HDR, ST, PLRZD, 5-PIN, 0.100"	P2	AMP	640454-5
DNP	P1		

Typical Performance: 2620MHz to 2690MHz Application Circuit

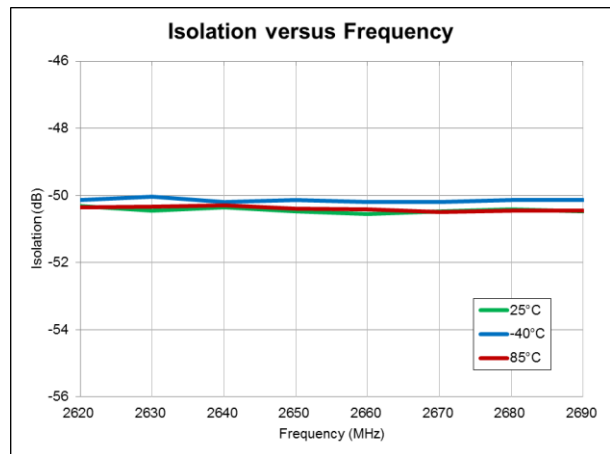
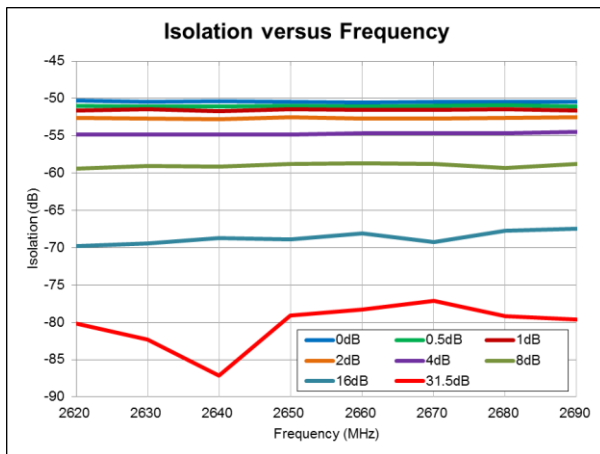
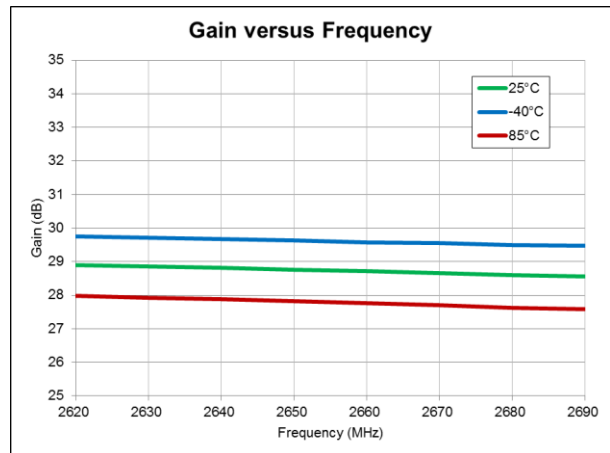
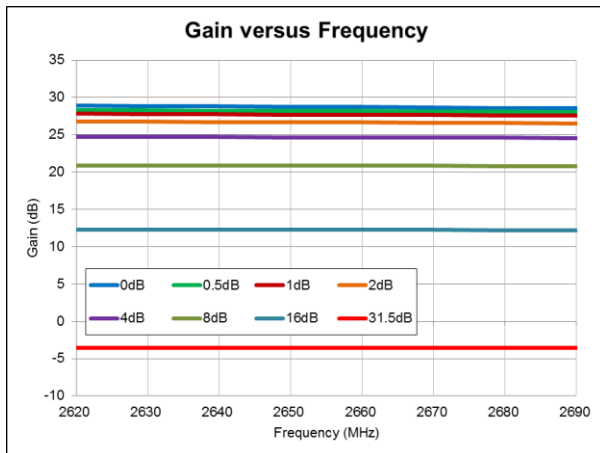
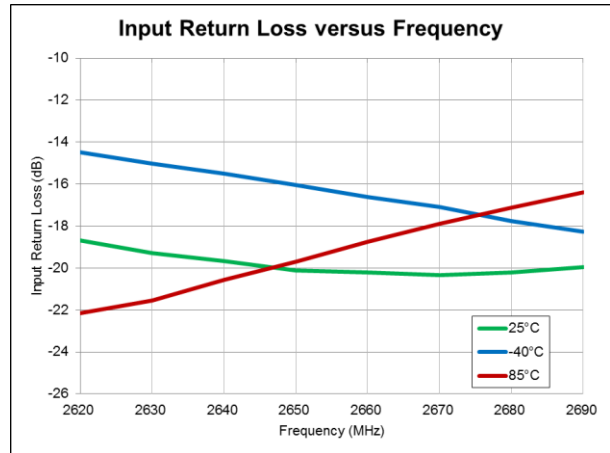
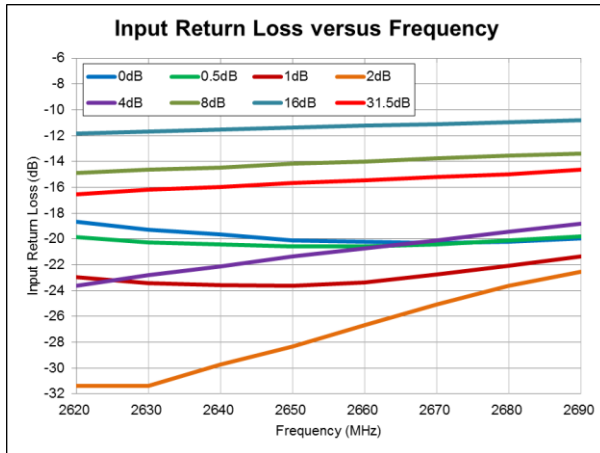

Typical Performance: 2620MHz to 2690MHz Application Circuit

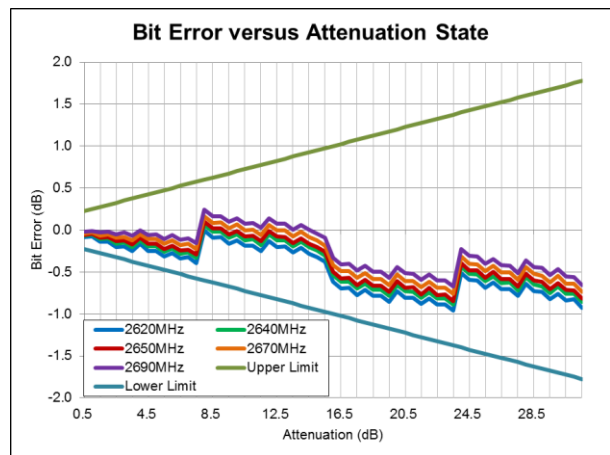
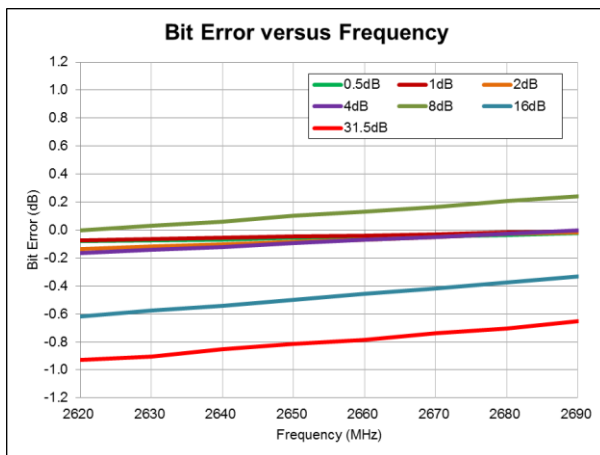
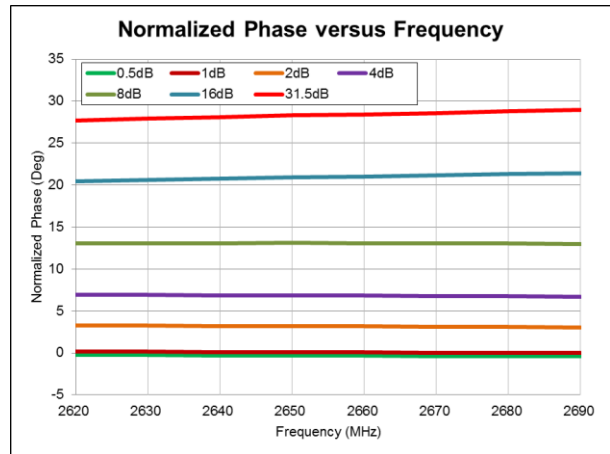
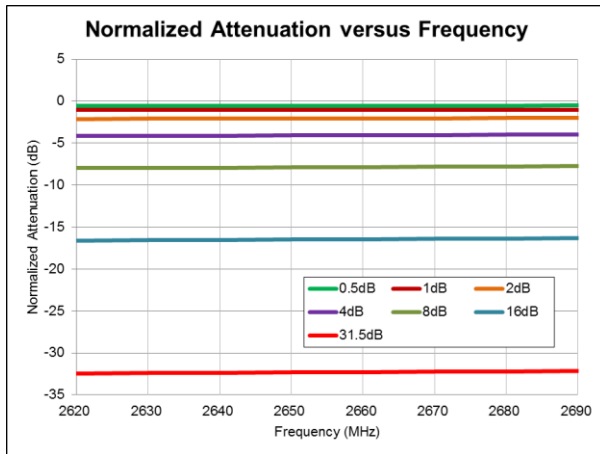
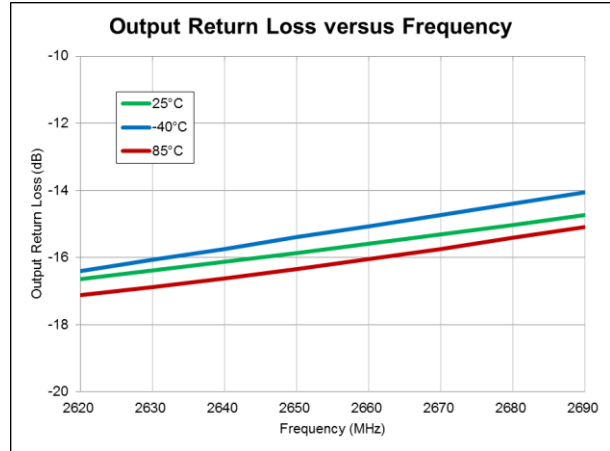
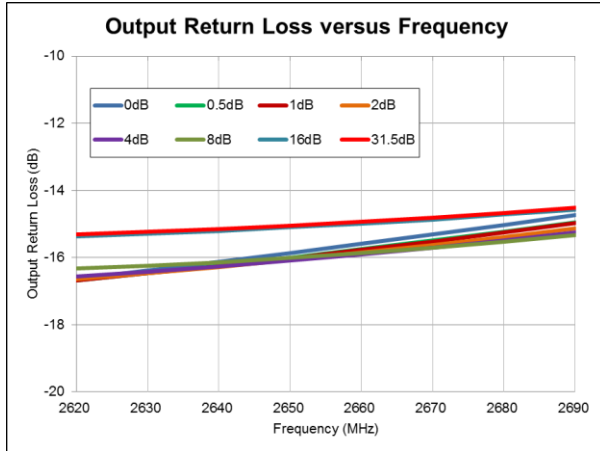

Typical Performance: 2620MHz to 2690MHz Application Circuit

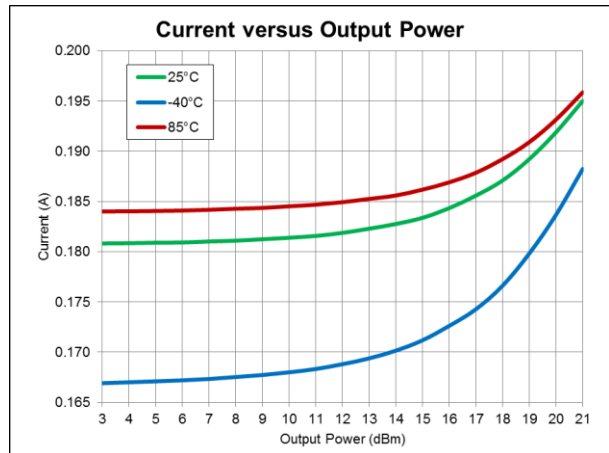
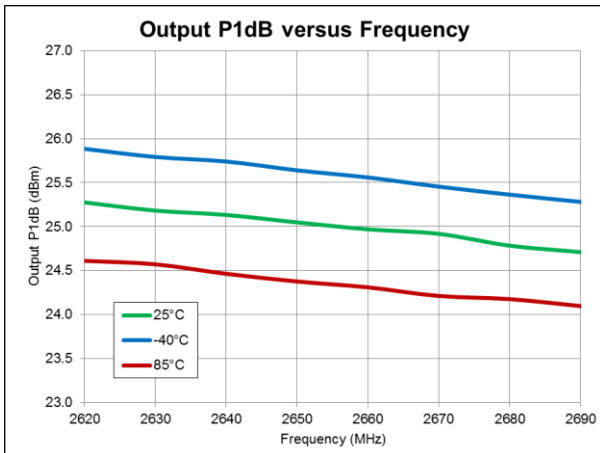
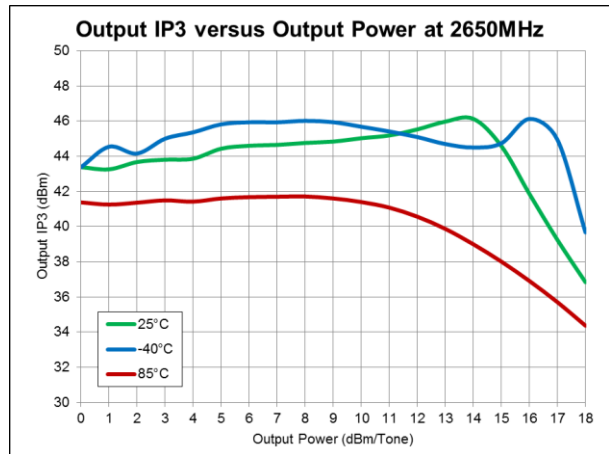
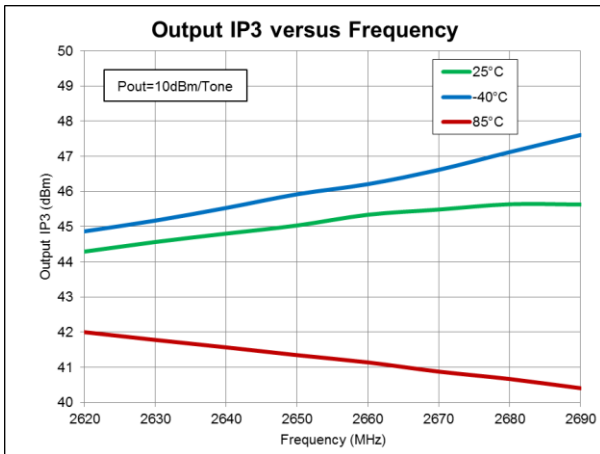
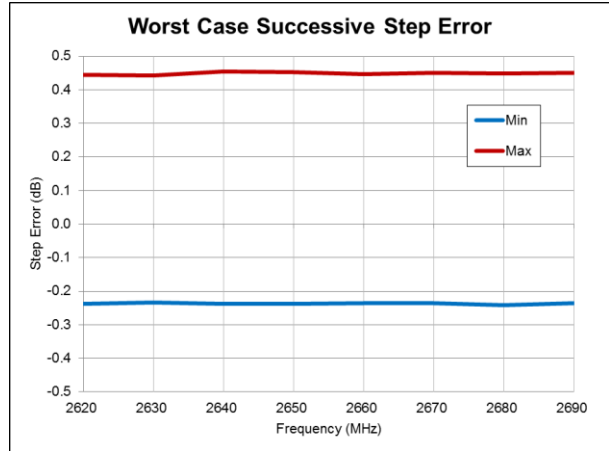
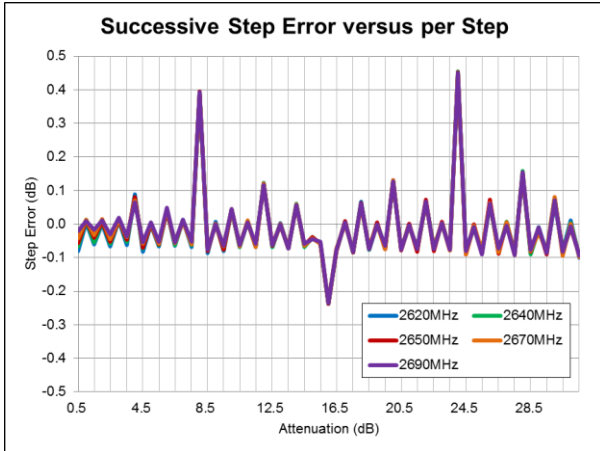

Typical Performance: 2620MHz to 2690MHz Application Circuit

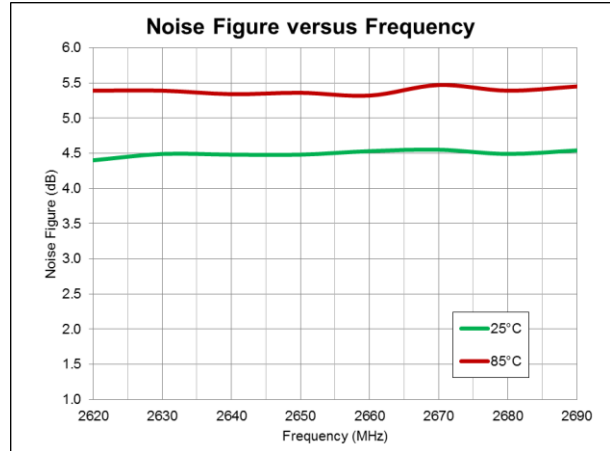
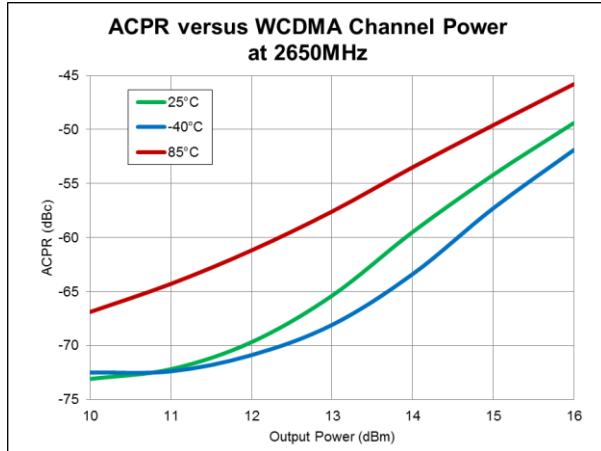

Evaluation Board Schematic 2620MHz to 2690MHz Application Circuit

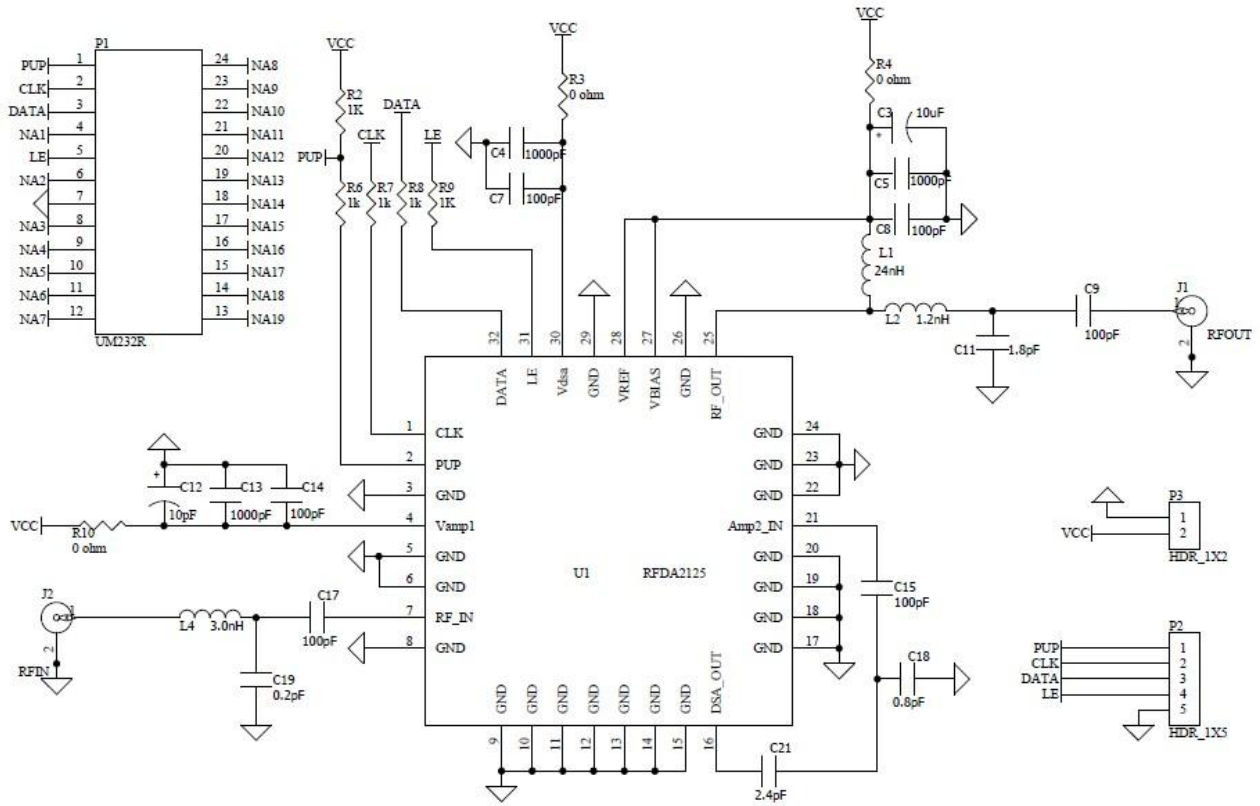

Evaluation Board Bill of Materials (BOM)

2620MHz to 2690MHz Application Circuit

Description	Reference Designator	Manufacturer	Manufacturer's P/N
Evaluation Board			RFDA2125410(A)
RFDA2125	U1	RFMD	RFDA2125
RES, 1K, 5%, 1/16W, 0603	R2, R6-R9	Panasonic Industrial Co.	ERJ-3GEYJ102
CAP, 100pF, 5%, 50V, COG, 0402	C17	Murata Electronics	GRM1555C1H101JA01D
CAP, 100pF, 5%, 50V, COG, 0402	C7-C9, C14-C15	Murata Electronics	GRM1555C1H101JA01D
CAP, 1000pF, 10%, 50V, X7R, 0402	C4-C5, C13	Murata Electronics	GRM155R71H102KA01D
CAP, 10µF, 20%, 20V, TANT-B	C3, C12	Murata Electronics	TAJB106M020RNJ
CAP, 0.2pF, +/-0.05pF, 50V, COG, 0402	C19	Murata Electronics	GJM1555C1HR20WB01D
CAP, 2.4pF, +/-0.1pF, 50V, COG, 0402	C21	Murata Electronics	GJM1555C1H2R4BB01D
CAP, 1.8pF, +/-0.1pF, 50V, HI-Q, 0402	C11	Murata Electronics	GJM1555C1H1R8BB01D
CAP, 0.8pF, +/-0.1pF, 50V, HI-Q, 0402	C18	Murata Electronics	GJM1555C1HR80BB01D
RES, 0Ω, 0603	R3-R4, R10	KOA Speer Electronics, Inc.	RK73Z1JLTD
IND, 3.0nH, +/-0.1nH, T/F, HI-Q, 0201	L4	Murata Electronics	LQP03TN3N0B00
IND, 1.2nH, +/-0.1nH, T/F, HI-Q, 0201	L2	Murata Electronics	LQP03TN1N2B00
IND, 24nH, 5%, W/W, 0603	L1	Coilcraft, Inc.	0603CS-24NXJBC
CONN, SMA, END LNCH, FLT, 0.062"	J1-J2	Emerson Network Power	142-0701-821
CONN, HDR, ST, PLRZD, 2-PIN, 0.100"	P3	AMP	640454-2
CONN, HDR, ST, PLRZD, 5-PIN, 0.100"	P2	AMP	640454-5
DNP	P1		

Truth Table

Control Bit						Gain Relative to Maximum Gain
D5	D4	D3	D2	D1	D0	
1	1	1	1	1	1	0dB
1	1	1	1	1	0	-0.5dB
1	1	1	1	0	1	-1dB
1	1	1	0	1	1	-2dB
1	1	0	1	1	1	-4dB
1	0	1	1	1	1	-8dB
0	1	1	1	1	1	-16dB
0	0	0	0	0	0	-31.5dB

Programming example – 6-Bit

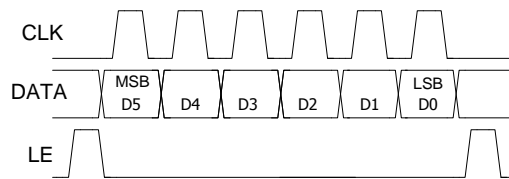

Power-up Programming Truth Table

PUP	Attenuator Setting
Low	Attenuation at max, 31.5dB
High	Attenuation at min, 0dB

Serial Port Interface

Logic Voltage Levels	
State	Logic
Low	0V to 0.8V
High	2.0V to 5.0V

SPI Timing Diagram

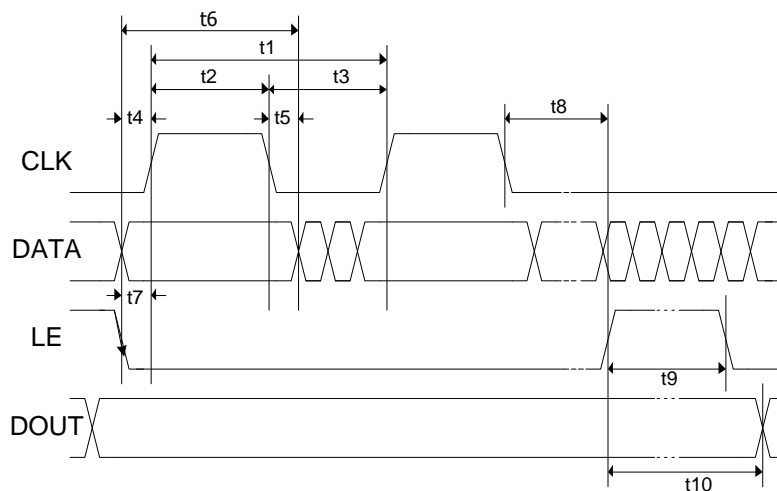

SPI Timing Diagram Specifications

Parameter	Limit	Unit	Comment
t1	25	MHz max	CLK Frequency
t2	20	ns min	CLK High
t3	20	ns min	CLK Low
t4	5	ns min	DATA to CLK Setup time
t5	5	ns min	DATA to CLK Hold time
t6	30	ns min	DATA Valid
t7	5	ns min	LE to CLK Setup time
t8	5	ns min	CLK to LE Setup time
t9	10	ns min	LE pulse width
t10	20	ns max	Output set

PIN Names and Descriptions:

Pin #	Pin Name	Description
1	SPI_CLK	Serial clock input
2	SPI_PUP	Power-up programming pin
3	GND	RF/DC Ground Connection
4	Vamp1	Supply voltage for amplifier 1
5	GND	RF/DC Ground Connection
6	GND	RF/DC Ground Connection
7	RF_IN	RF Input, AC coupled
8	GND	RF/DC Ground Connection
9	GND	RF/DC Ground Connection
10	GND	RF/DC Ground Connection
11	GND	RF/DC Ground Connection
12	GND	RF/DC Ground Connection
13	GND	RF/DC Ground Connection
14	GND	RF/DC Ground Connection
15	GND	RF/DC Ground Connection
16	DSA_OUT	Digital step attenuator output
17	GND	RF/DC Ground Connection
18	GND	RF/DC Ground Connection
19	GND	RF/DC Ground Connection
20	GND	RF/DC Ground Connection
21	Amp2_IN	RF input of amplifier 2
22	GND	RF/DC Ground Connection
23	GND	RF/DC Ground Connection
24	GND	RF/DC Ground Connection
25	RF_OUT	RF output, supply voltage for amplifier 2
26	GND	RF/DC Ground Connection
27	VBIAS	Supply voltage for the active bias circuit
28	VREF	Control input to the active bias circuit to set I_{CQ} . Can be used as a power-down pin
29	GND	RF/DC Ground Connection
30	VDSA	Supply voltage for digital step attenuator and SPI
31	SPI_LE	Serial latch enable input
32	SPI_DATA	Serial data input

Package Drawing 5.2mm x 5.2mm Laminate Module

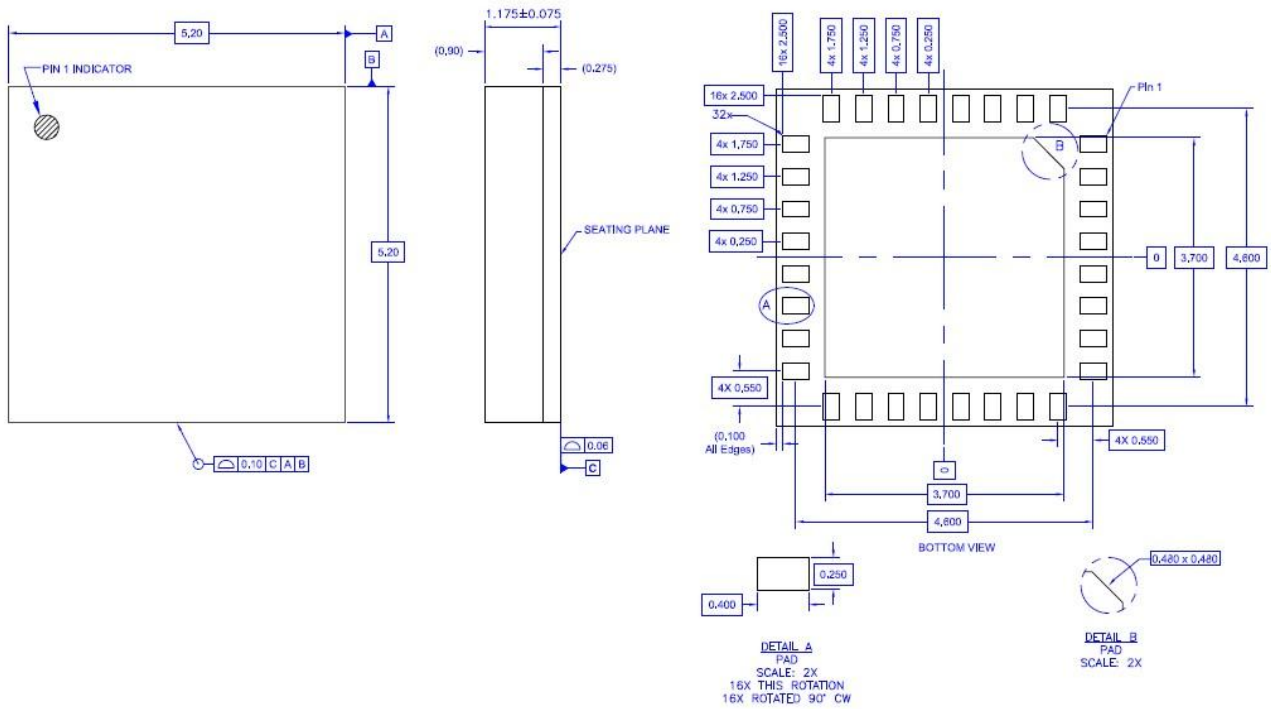

Branding Diagram

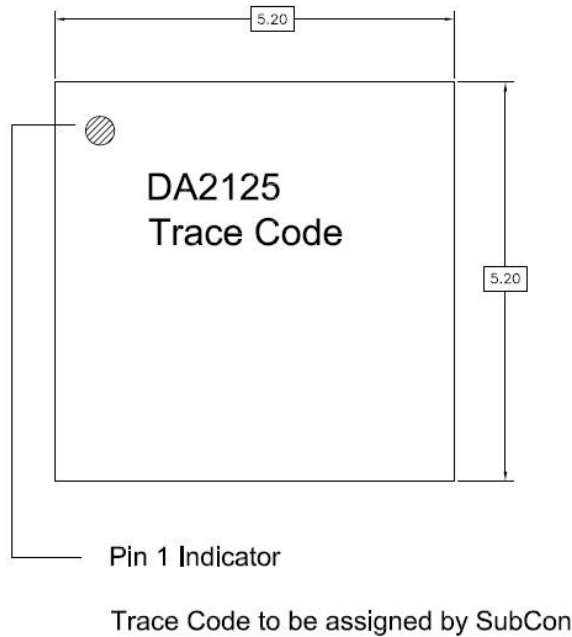

X-ON Electronics

Largest Supplier of Electrical and Electronic Components

Click to view similar products for [RF Amplifier](#) category:

Click to view products by [Qorvo](#) manufacturer:

Other Similar products are found below :

[A82-1](#) [BGA622H6820XTSA1](#) [BGA 728L7 E6327](#) [BGB719N7ESDE6327XTMA1](#) [HMC397-SX](#) [HMC405](#) [HMC561-SX](#) [HMC8120-SX](#)
[HMC8121-SX](#) [HMC-ALH382-SX](#) [HMC-ALH476-SX](#) [SE2433T-R](#) [SMA3101-TL-E](#) [SMA39](#) [A66-1](#) [A66-3](#) [A67-1](#) [LX5535LQ](#) [LX5540LL](#)
[MAAM02350](#) [HMC3653LP3BETR](#) [HMC549MS8GETR](#) [HMC-ALH435-SX](#) [SMA101](#) [SMA32](#) [SMA411](#) [SMA531](#) [SST12LP19E-QX6E](#)
[WPM0510A](#) [HMC5929LS6TR](#) [HMC5879LS7TR](#) [HMC1126](#) [HMC1087F10](#) [HMC1086](#) [HMC1016](#) [SMA1212](#) [MAX2689EWS+T](#)
[MAAMSS0041TR](#) [MAAM37000-A1G](#) [LTC6430AIUF-15#PBF](#) [CHA5115-QDG](#) [SMA70-2](#) [SMA4011](#) [A231](#) [HMC-AUH232](#) [LX5511LQ](#)
[LX5511LQ-TR](#) [HMC7441-SX](#) [HMC-ALH310](#) [XD1001-BD-000V](#)