

RFFM5765Q

Tested in Accordance with AEC-Q100
802.11b/g/n WiFi Front End Module

The RFFM5765Q provides a complete integrated solution in a single front end module (FEM) for automotive WiFi applications, 802.11b/g/n, and Bluetooth® systems. The ultra-small form factor and integrated matching greatly reduces the number of external components and layout area in the customer application. This simplifies the total front end solution by reducing the bill of materials, system footprint, and manufacturing cost. The RFFM5765Q integrates a 2.4GHz power amplifier (PA), low noise amplifier (LNA), power detector coupler for improved accuracy, and some filtering for harmonic rejection. The RFFM5765Q is capable of receiving WiFi and Bluetooth simultaneously and is tested in accordance with AEC-Q100 standard. The device is provided in a 3.0mm x 3.0mm x 0.5mm, 16-pin package. This module meets or exceeds the RF front end needs of IEEE 802.11b/g/n WiFi RF systems.



Package: QFN, 16-pin,
3.0mm x 3.0mm x 0.5mm

Features

- Single Supply Voltage 3.0V to 4.8V
- Input and Output Matched to 50Ω
- Gain = 30dB
- $P_{OUT} = 19\text{dBm}$, 11g, 64QAM at <4% Dynamic EVM
- $P_{OUT} = 22\text{dBm}$, 11b, CCK 11Mbps, Spectral Mask and ACPR compliant

Applications

- Automotive WiFi
- WiFi Direct
- Automotive Diagnostics
- WiFi Infotainment
- 2.5GHz ISM Band Solutions
- Portable Battery-Powered Equipment

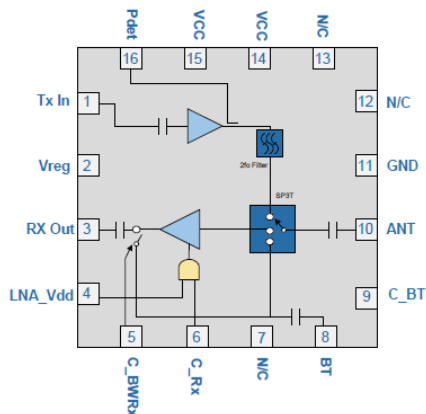

Functional Block Diagram

Ordering Information

RFFM5765QSQ	Standard 25-piece bag
RFFM5765QSR	Standard 100-piece bag
RFFM5765QTR7	Standard 2500-piece reel
RFFM5765QPCK-410	Fully assembled evaluation board

Absolute Maximum Ratings

Parameter	Rating	Unit
DC Supply Voltage (Continuous with No Damage)	6.0	V
DC Supply Current	700	mA
Case Operating Temperature	-40 to +85	°C
Storage Temperature	-40 to +150	°C
Maximum Tx Input Power into 50Ω Load for 11b/g/n (No Damage)	+5	dBm
Maximum Rx Input Power (No Damage)	+5	dBm
Moisture Sensitivity	MSL2	



Caution! ESD sensitive device.



RFMD Green: RoHS status based on EU Directive 2011/65/EU (at time of this document revision), halogen free per IEC 61249-2-21, < 1000ppm each of antimony trioxide in polymeric materials and red phosphorus as a flame retardant, and <2% antimony in solder.

Exceeding any one or a combination of the Absolute Maximum Rating conditions may cause permanent damage to the device. Extended application of Absolute Maximum Rating conditions to the device may reduce device reliability. Specified typical performance or functional operation of the device under Absolute Maximum Rating conditions is not implied.

Nominal Operating Parameters

Parameter	Specification			Unit	Condition
	Min	Typ	Max		
2.4GHz Transmit Parameters					
Compliance					IEEE802.11b/g/n Standards, FCC CFG 15.247, .205, .209, EN, and JDEC
Operating Conditions					$V_{CC} = 3.0V$ to $4.2V$; $V_{REG} = 3.0V$ to $3.2V$; $P_{OUT}(g/n) = 19dBm$; Frequency 2412MHz to 2484MHz; Switch Control voltage: $3.0V$ to $3.6V$; 11g 54Mbps and 11n MCS7 signals; Temp = $-40^{\circ}C$ to $+85^{\circ}C$; Unless noted otherwise.
Frequency	2.4		2.5	GHz	
Voltage Supply	3.0	3.3	4.2	V	Power Amplifier Voltage Supply (V_{CC})
V_{REG} Voltage					
ON	3.0	3.1	3.2	V	PA in "ON" state
OFF		0.00	0.20	V	PA in "OFF" state
Output Power					
11g/n	17	18.5		dBm	$V_{CC} > 3.0V$
	18	19		dBm	$V_{CC} > 3.3V$
11b	19	22		dBm	11Mbps CCK signal, $V_{CC} \geq 3.3V$
EVM		3.3	4	%	$P_{OUT}(g/n) =$ Rated Output Power, 54Mbps OFDM, 50Ω, see note 1
Adjacent Channel Power					$P_{OUT}(b) = 22dBm$, 11Mbps CCK signal, $V_{CC} \geq 3.3V$, see note 4
ACP1		-36	-33	dBc	+/- 11MHz Offset from carrier
ACP2		-56	-53	dBc	+/- 22MHz Offset from carrier
Gain	25.5	30	34.5	dB	
Gain Variation Slope					At rated power and a given supply voltage
Range	3.0		4.2	V	
V_{CC} (Average)			0.5	dB/V	
V_{CC} (Instantaneous)			1	dB/V	
Frequency	-0.5		+0.5	dB	2.4GHz to 2.5GHz
Over Temperature	-1.75		+1.75	dB	$V_{CC} = 3.3V$, $V_{REG} = 3.1V$, Freq = 2.45GHz
Typical Input Power					
11g/n		-9		dBm	
11b		-5		dBm	

Parameter	Specification			Unit	Condition
	Min	Typ	Max		
2.4GHz Transmit Parameters (continued)					
Power Detect					
Power Range	0		23	dBm	
Voltage Range	0.1		1.5	V	
Resistance		10		k Ω	
Capacitance			10	pF	
Sensitivity					
0 < P _{OUT} < 6dBm	3			mV/dB	
6 < P _{OUT} < 23dBm	8		350	mV/dB	
Current Consumption (I _{CC})					
Quiescent Current		110	150	mA	Over V _{CC} , and Temp range
11g/n		215	250	mA	At rated power, over Freq, V _{CC} , and Temp range
11b		260	340	mA	At rated power, over Freq, V _{CC} , and Temp range
I _{REG}			5	mA	V _{REG} > 3.0V
V _{CC} Leakage Current		2	10	μ A	V _{CC} = 4.8V, V _{REG} = C_BT = C_RX = C_BWRX < 0.2V
Input Port Impedance		50		Ω	
Input Port Return Loss	10	15		dB	
Ruggedness					No Damage Conditions: max operating voltage, max input power, max temperature
Output VSWR			10:1		
Input Power			-5	dBm	
Stability					PA must be stable from 0dBm to 20dBm. No spurs above -41.25dBm for non-harmonic related signals.
Output VSWR	6:1				CW signal, P _{OUT} = 20dBm, all phases
Out-of-Band Emissions 2310MHz to 2390MHz and 2483.5MHz to 2500MHz (FCC restricted bands)			-41.25	dBm/MHz	P _{OUT} = 16.5dBm, 54Mbps OFDM Modulation, 64QAM, RBW = 1MHz, VBW = 100kHz, V _{CC} = 3.3V, V _{REG} = 3.1V, Note 4
			-41.25	dBm/MHz	P _{OUT} = 20.5dBm, 11Mbps CCK Modulation, BT = 0.45, RBW = 1MHz, VBW = 100kHz, V _{CC} = 3.3V, V _{REG} = 3.1V
Harmonics					11b modulation, 1Mbps, BW = 1MHz, up to 3:1 load, P _{OUT} = 20dBm
Second			-23	dBm	4.80GHz to 5.00GHz
Third			-20	dBm	7.20GHz to 7.50GHz
Turn-on/off Time		0.5	1.0	μ s	Output stable to within 90% of final gain, Note 1

Parameter	Specification			Unit	Condition
	Min	Typ	Max		
2.4GHz Receive Parameters					
Compliance					IEEE802.11b, IEEE802.11g/n, FCC CFG 15.247, .205, .209, EN, and JDEC
Nominal Conditions					$V_{DD} = 3.0V$ to $4.2V$; Switch Control: $3.0V$ to $3.6V$; Freq = $2412MHz$ to $2484MHz$; CW signal; Temp = $-40^{\circ}C$ to $+85^{\circ}C$; Unless noted otherwise
Frequency	2.4		2.5	GHz	
LNA Voltage Supply (LNA V_{CC})	3.0	3.3	4.2	V	LNA V_{CC} can be tied to V_{BATT} at all times
LNA Current		16	18	mA	LNA in "ON" state
	0		5	μA	LNA in "OFF" state ($C_{RX} = low$, LNA $V_{CC} = ON$)
LNA Input P1dB	-10	-7	-4.5	dBm	
Gain					
WiFi Rx Gain	13	18	21	dB	WiFi Rx mode, $V_{DD} \geq 3.3V$
Simultaneous WiFi/BT Rx Mode	9	13	16	dB	WiFi Rx/BT Mode, LNA "ON", $V_{DD} \geq 3.3V$
Noise Figure					$V_{CC} > 3.3V$, including switch
WiFi Rx		2.1	3.5	dB	WiFi Rx mode (LNA "ON")
Simultaneous WiFi/BT Rx Mode		3	4	dB	WiFi Rx/BT Mode (LNA "ON")
Passband Ripple	-0.2		+0.2	dB	WiFi Rx Mode
	-0.5		+0.5	dB	WiFi Rx/BT Mode
WiFi Rx Port Return Loss	8.5			dB	
	5			dB	Switch in WiFi Rx/Bluetooth Mode
WiFi Rx Port Impedance		50		Ω	No external matching
Bluetooth Parameters					
Frequency	2.4		2.5	GHz	
Insertion Loss					
BT Tx/Rx only		1.2	1.5	dB	Bluetooth mode
BT/WiFi Rx Gain (simultaneous mode)	9	13	16	dB	WiFi Rx/BT Mode, LNA "ON"
Passband Ripple	-0.2		+0.2	dB	Bluetooth mode
	-0.5		+0.5	dB	WiFi Rx/BT mode
Input P1dB	27	30		dB	BT Mode, over temp, $C_{BT} = 3.3V$ to $3.6V$
Bluetooth Port Return Loss	8.5			dB	Switch in Bluetooth Mode
	6			dB	Switch in WiFi Rx/Bluetooth Mode

Parameter	Specification			Unit	Condition
	Min	Typ	Max		
Other Requirements					
Antenna Port Impedance					
Output		50		Ω	
Return Loss		10		dB	
Isolation					
Antenna to Receive	20			dB	In BT Mode (measured from ANT to Rx port)
Antenna to Bluetooth	20			dB	In Tx Mode (measured from ANT to BT port)
Antenna to Receive	20			dB	In Tx Mode (measured from ANT to Rx port)
Switch Control Voltage					C_RX, C_BT, and C_BW Rx control lines
Low		0	0.2	V	Switch is in the low state (L)
High	1.7	3.3	3.6	V	Switch is in the high state (H)
Switch Control Current		2	10	μA	Per control line (C_BT, C_BWRX)
C_RX Current		100	150	μA	Over V _{CC} , Frequency and Temperature.
Switch Control Speed			200	ns	
Switch P1dB		28		dBm	
ESD					
Human Body Model	500			V	EIA/JESD22-114A RF pins
	1000			V	EIA/JESD22-114A DC pins
Charge Device Model	500			V	JESD22-C101C all pins

Note 1: The PA module must operate with gated bias voltage input at 1% to 99% duty cycle.

Note 3: Values to be agreed to upon characterization data review: current, gain, return loss, detector sensitivity and output power.

Note 4: The output power for channels 1 and 11 may be reduced to meet FCC restricted band requirements.

Switch Control Logic Table

Mode	VREG	C_RX	C_BT	C_BWRX
Standby	Low	Low	Low	Low
WiFi Tx	High	Low	Low	Low
WiFi Rx	Low	High	Low	Low
WiFi Rx/BT*	Low	High	Low	High
BT Rx	Low	Low	High	Low
BT Tx	Low	Low	High	Low

*The FEM can be placed in receive WiFi and Bluetooth modes simultaneously with increased insertion loss.

Transmit Performance Plots

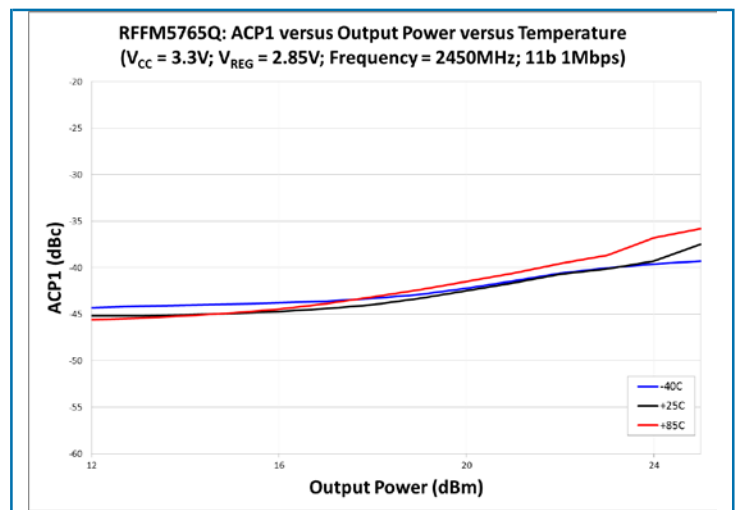
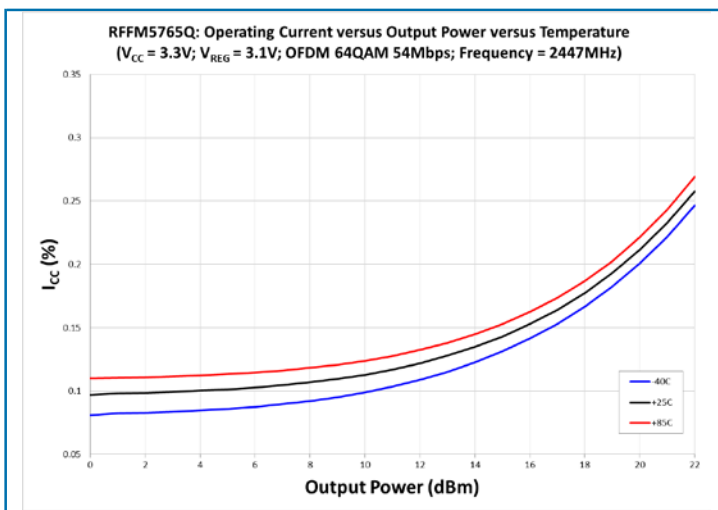
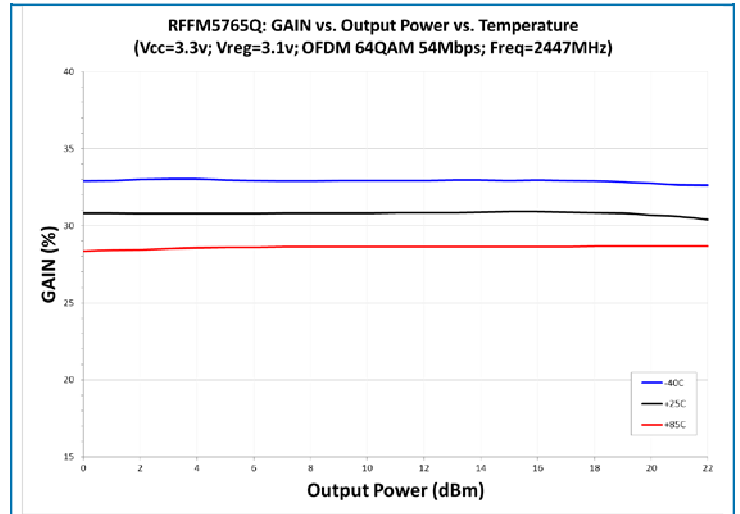
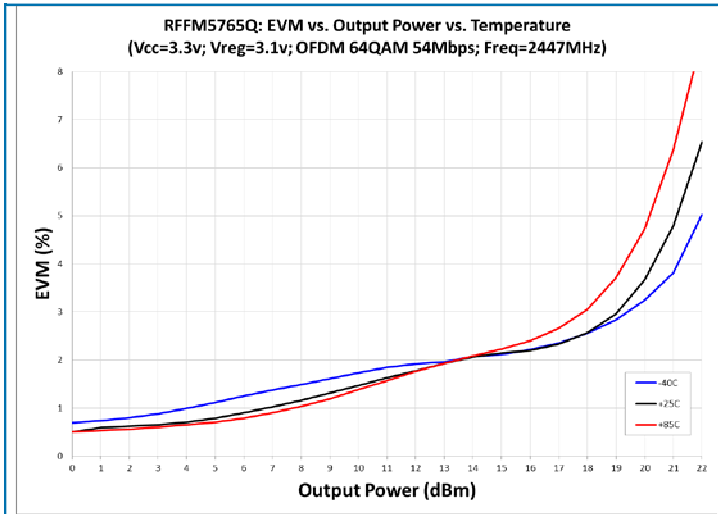

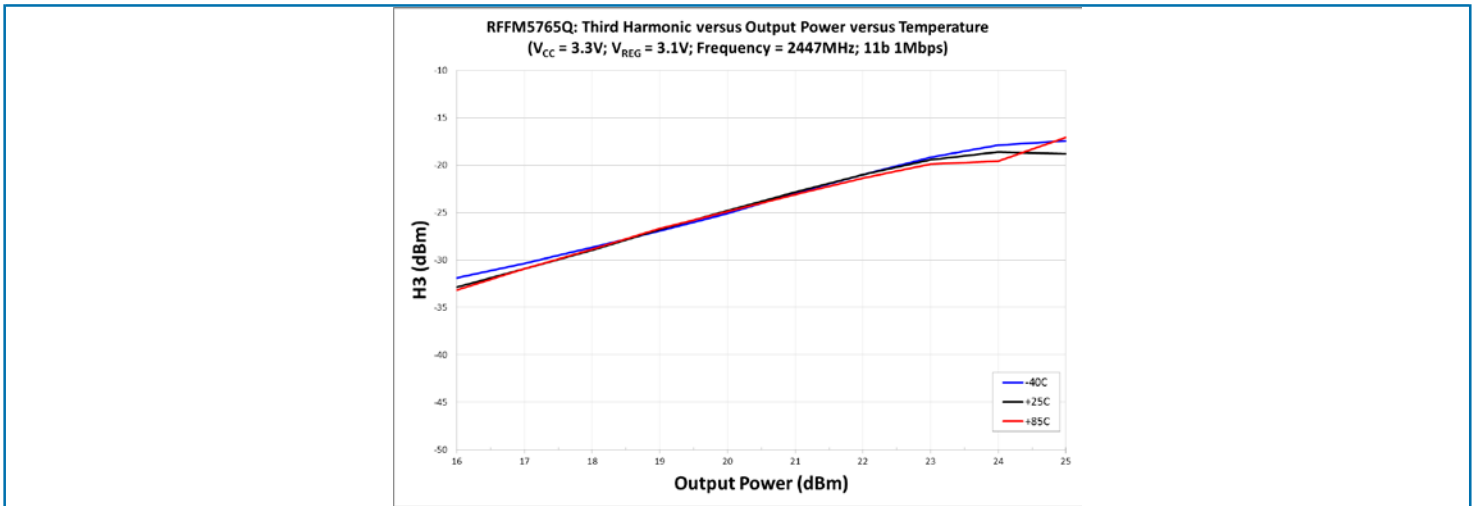
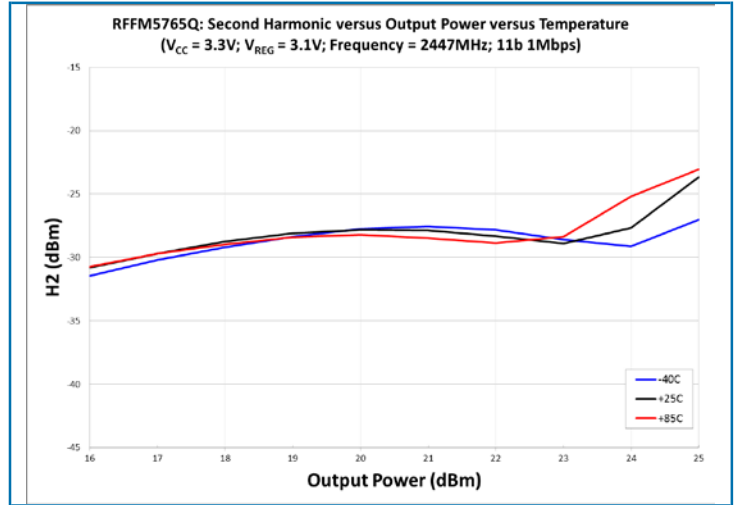
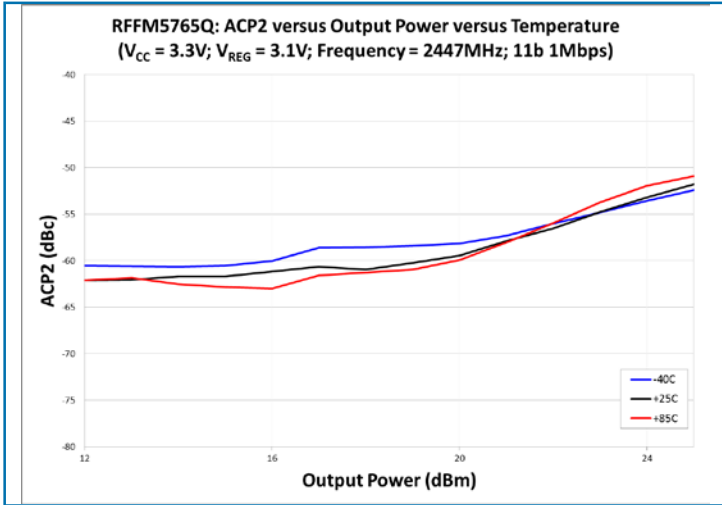

Receive Performance Plots

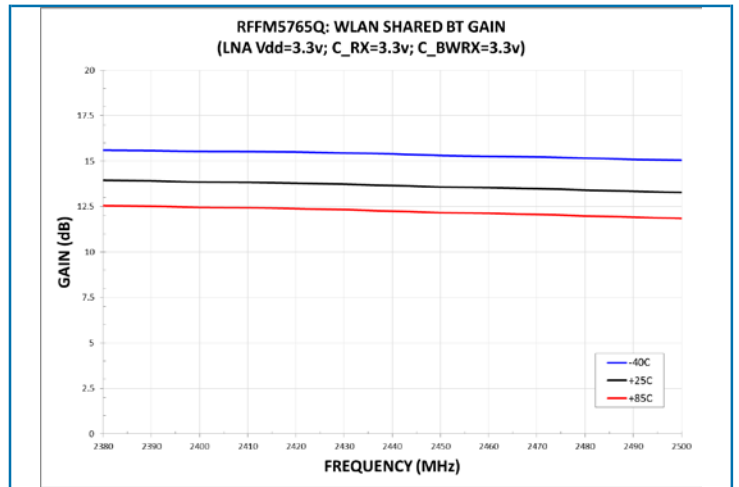
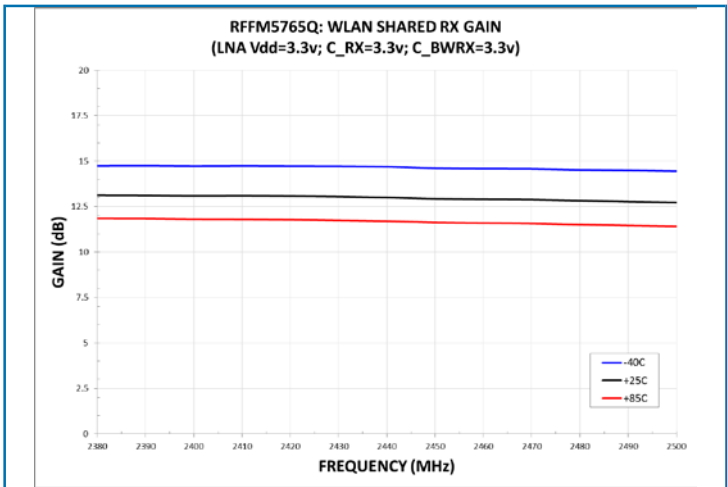
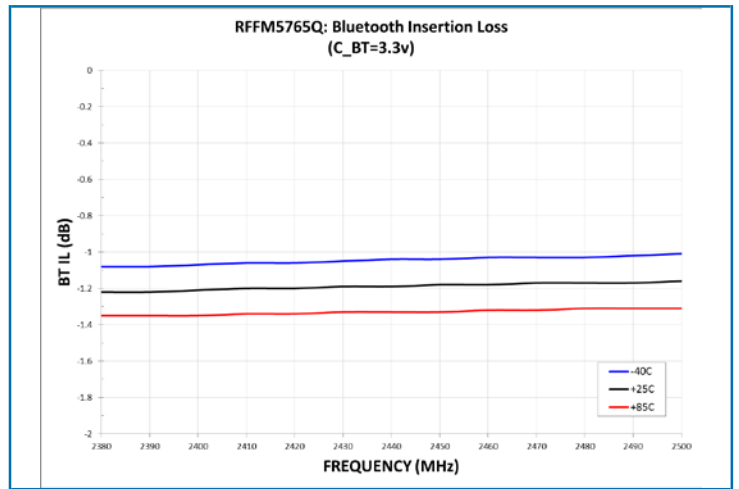
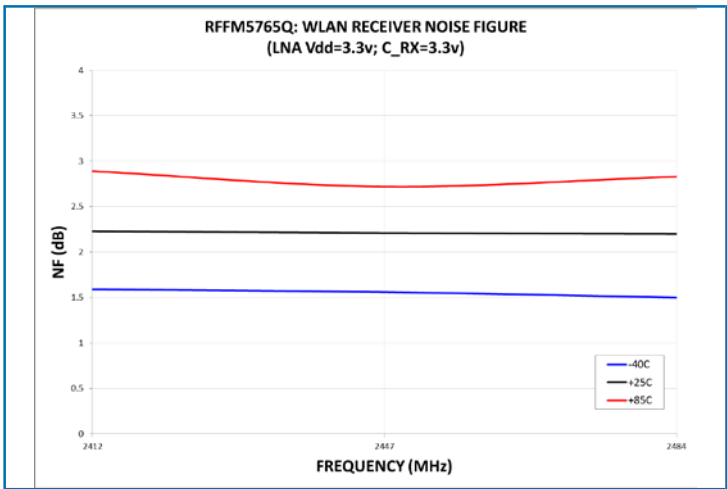
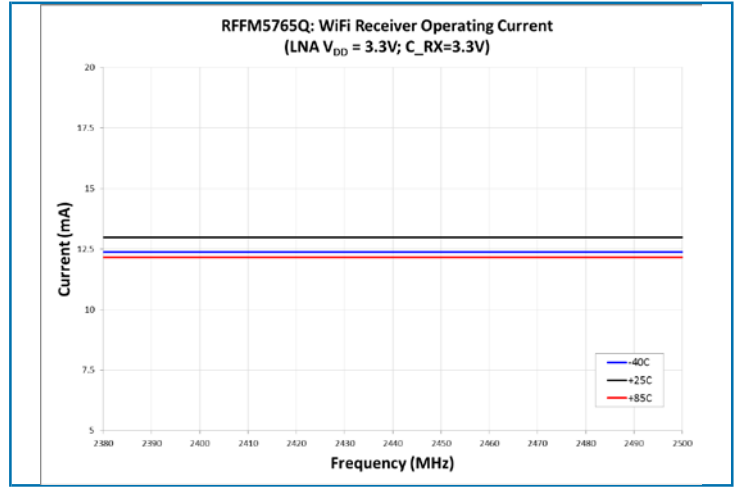
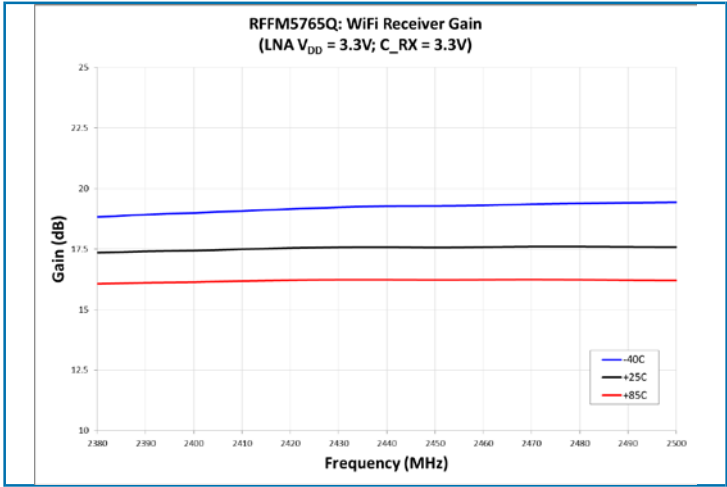

Application Schematic

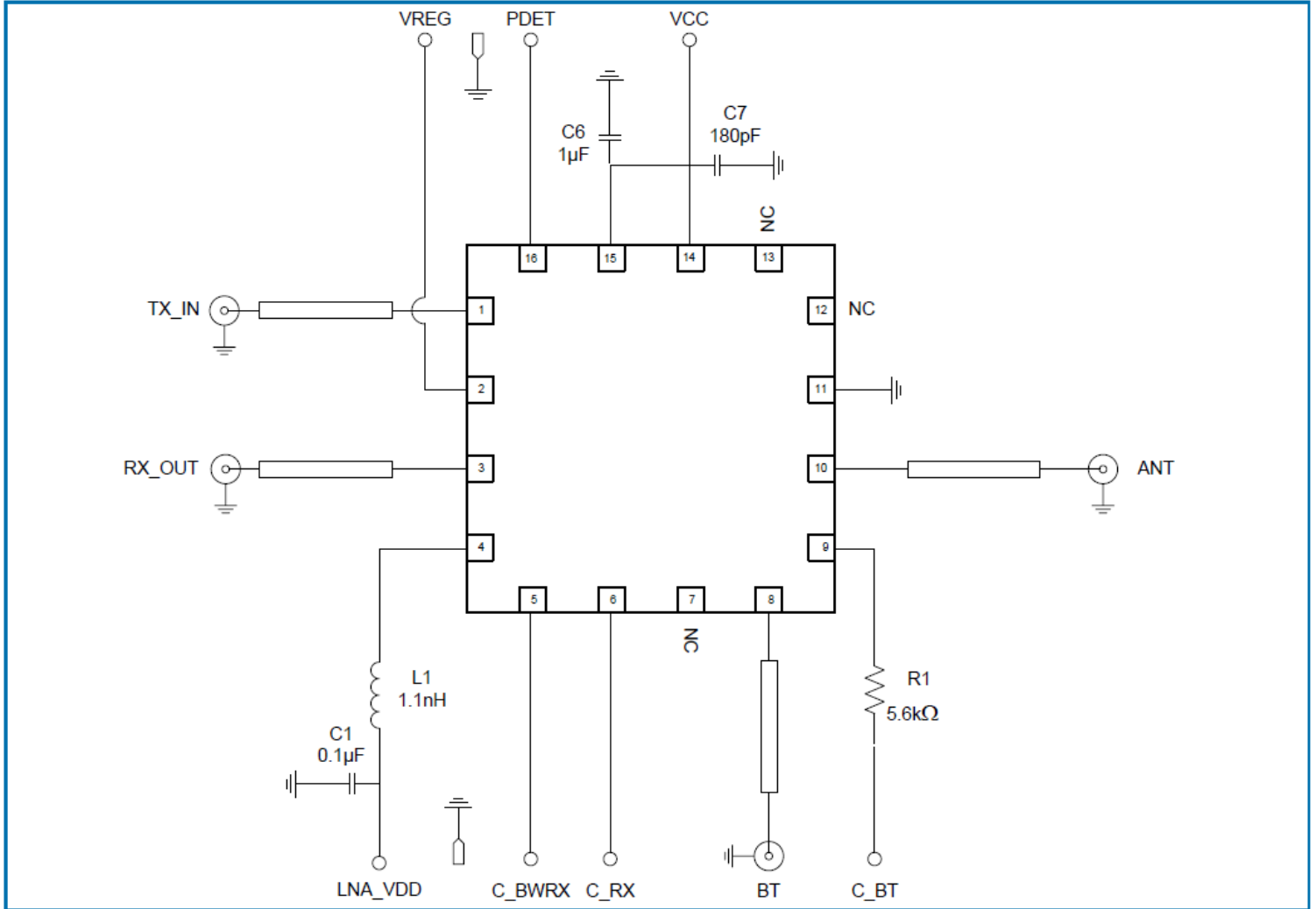

Pin Out

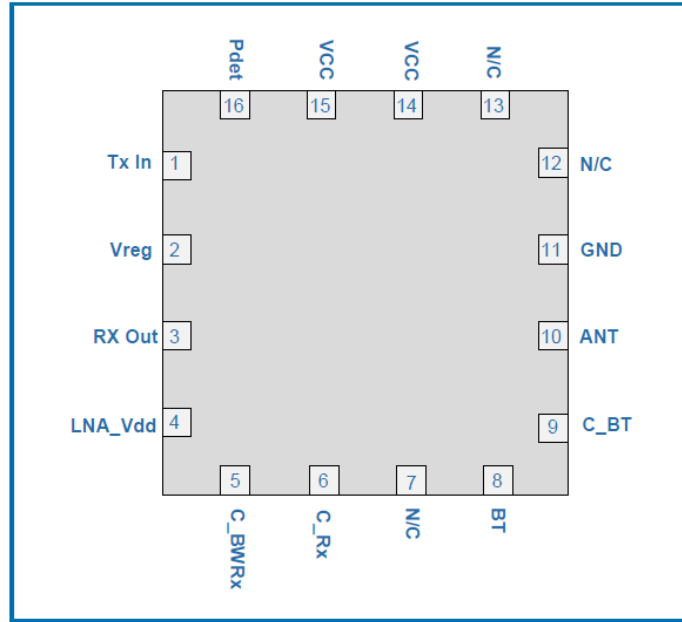

Package Drawing

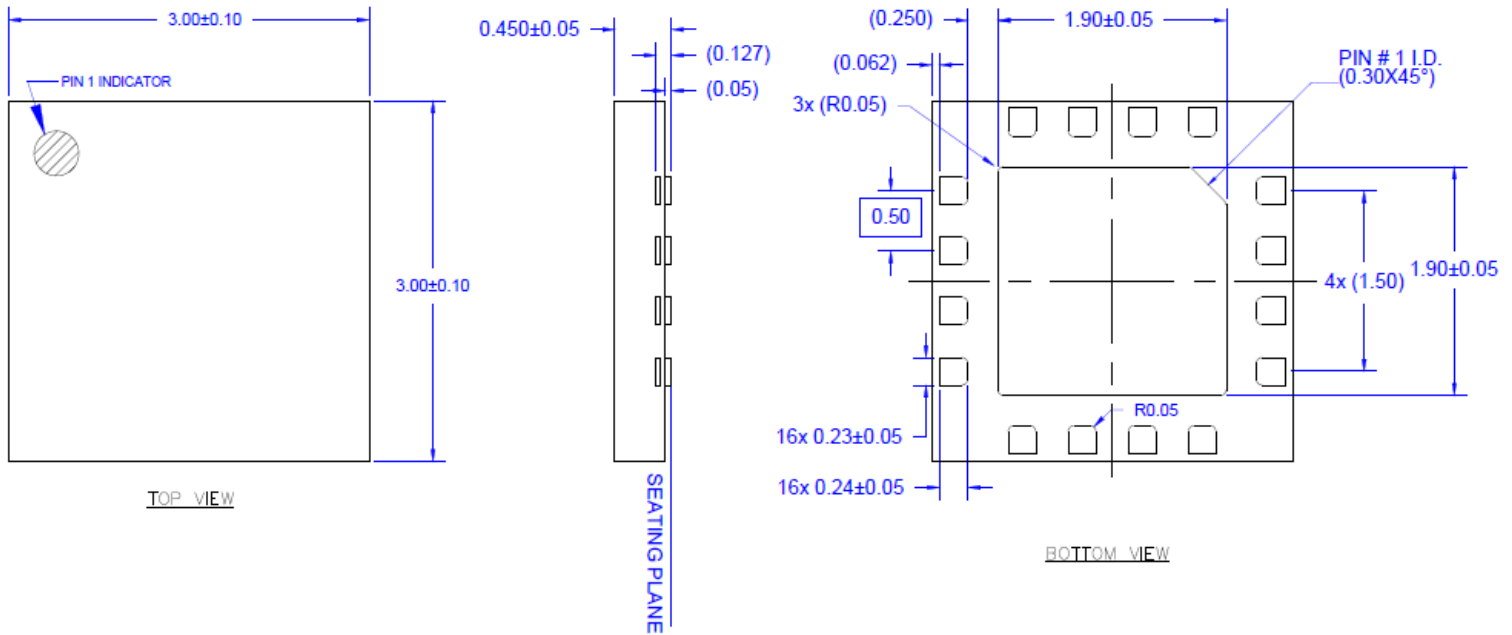

PCB Pattern

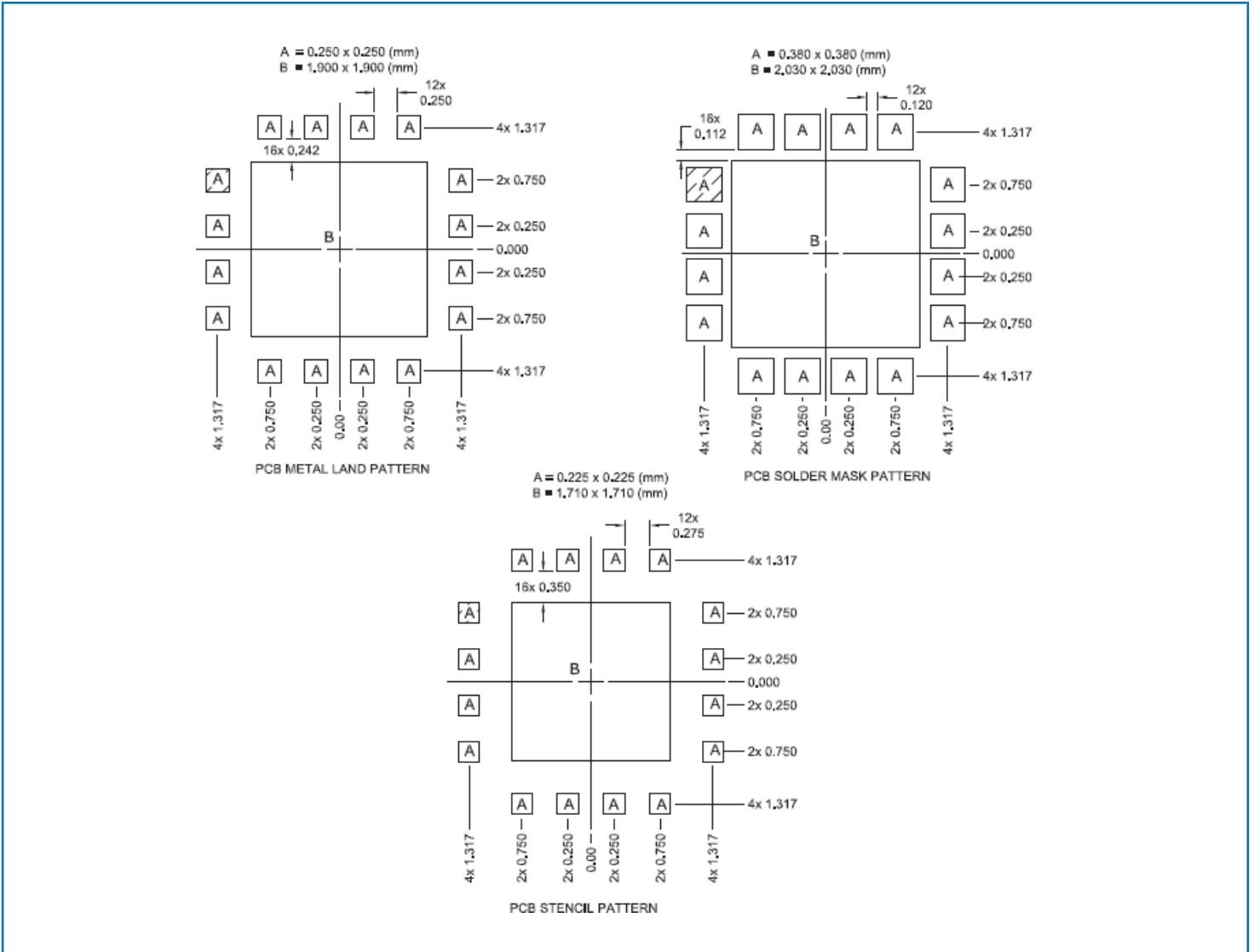

Pin Names and Descriptions

Pin	Name	Description
1	TX_IN	RF input for the PA. Input is matched to 50Ω and DC block is provided internally.
2	VREG	Supply voltage for the bias control circuit, and the Tx control port of the SP3T which is also tied to this pin. An external bypass capacitor may be needed on the V _{REG} line for decoupling purposes.
3	RX_OUT	Receive port output. Internally matched to 50Ω. DC block provided internally.
4	LNA_VDD	Supply voltage for the LNA.
5	C_BWRX	SPST switch control pin. (Simultaneous WiFi and BT receive.) See truth table for proper level.
6	C_RX	Receive switch control pin. See switch truth table for proper level.
7	N/C	No connect.
8	BT	RF bidirectional port for Bluetooth. Input is matched to 50Ω and DC block is provided internally.
9	C_BT	Bluetooth switch control pin. See truth table for proper level.
10	ANT	Port matched to 50Ω and is DC blocked internally.
11	GND	Ground.
12	N/C	No connect.
13	N/C	No connect.
14	VCC	Supply voltage for the PA.
15	VCC	Supply voltage for the PA.
16	PDET	Power detector voltage for Tx section. PDET voltage varies with output power. May need external decoupling capacitor for noise bypassing. May need external circuitry to bring output voltage to desired level.

Timing Diagram

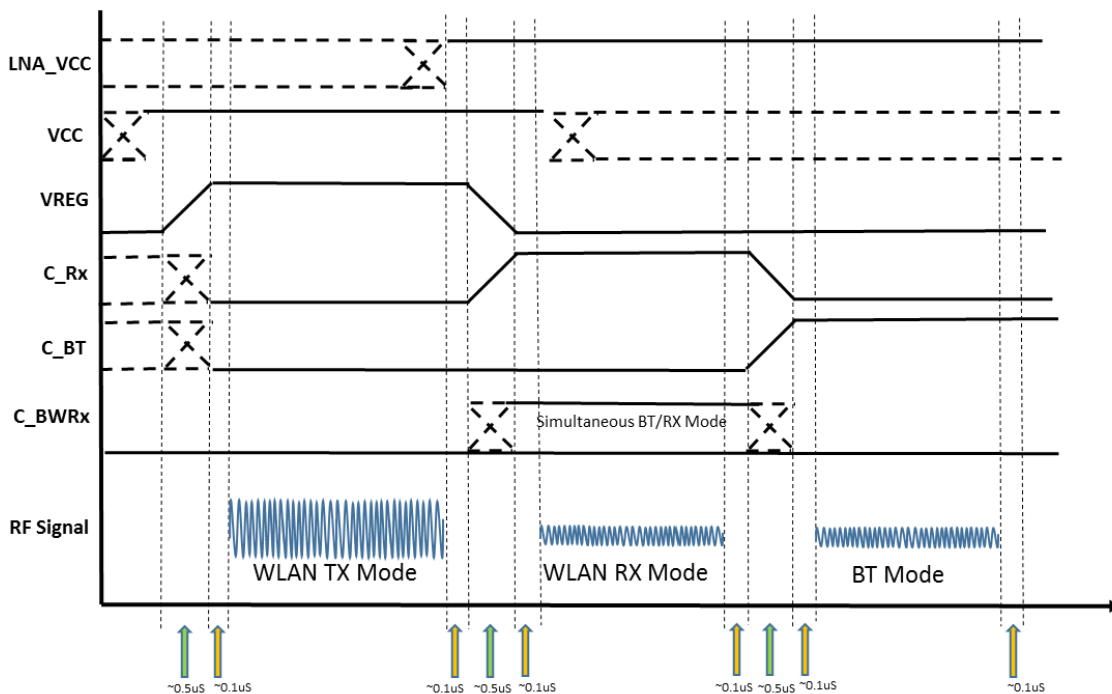

Theory of Operation

The RFFM5765Q front end module (FEM) is designed for automotive WiFi applications in the 2.5GHz ISM band. It can be applied in many portable applications such as handsets, portable media players, and portable battery power equipment. This highly integrated module can be connected directly to the battery without additional voltage regulators.

WiFi Transmit Mode

The RFFM5765Q requires a single positive supply (V_{CC}), a positive supply for switch controls, and a regulated supply for the V_{REG} to maintain nominal bias current. The RFFM5765Q transmit path has a typical gain of 30dB from 2.4GHz to 2.5GHz, and delivers 19dBm typical output power under 54Mbps OFDM modulation and 22dBm under 1Mbps 11b modulation. The RFFM5765Q contains basic filter components to produce a bandpass response for the transmit path. Due to space constraints inside the module, filtering is limited to a few resonant poles and additional filters may be required depending upon the end-user's application. While in transmit mode, the active components are the power amplifier (PA) and the Tx branch of the SP3T switch. Refer to the logic control table for proper settings.

Tx Biasing Instructions

- Connect the Tx input (pin-1) to a signal generator and a spectrum analyzer at the antenna output (pin-10)
- Set V_{CC} to 3.3V with V_{REG} set to 0V
- Turn V_{REG} ON and set voltage to 3.1V. V_{REG} controls the current drawn by the PA and it should quickly reach a quiescent current of approximately $110\text{mA} \pm 20\text{mA}$. Care must be exercised not to exceed 3.5V on the V_{REG} pin or the part may be damaged.
- Control bias to the transmit branch of the SP3T switch is tied directly to V_{REG}
- The SP3T controls for the off branches (C_{RX} and C_{BT}) must be set to a logic "low" (0.2V max) or grounded. In the event that one of these branches is left floating or in a logic "high" the performance of the PA will degrade significantly. Likewise, unused

RF ports must be terminated in 50 Ω to simulate actual system conditions and prevent RF signals from coupling back to the PA.

- Turn RF ON

WiFi Receive Mode

Within the frequency band of operation 2.4GHz to 2.5GHz, the RFFM5765Q WiFi receive path has a typical gain of 18dB and a NF of 2.1dB with about 10mA of current. In Rx mode, only the Rx branch of the SP3T and the LNA are active. Refer to the logic control table for proper settings.

Rx Biasing Instructions

- Connect the Rx input (ANT/pin-10) to a signal generator and a spectrum analyzer at the Rx output (pin-3). A VNA may be used as well.
- Turn the LNA bias ON (pin-4) and set the voltage to 3.3V.
- Set C_{RX} (pin-6) high. This turns ON the receive branch of the SP3T.
- The SP3T controls for the off branches (V_{REG} and C_{BT}) must be set to a logic "low" (0.2V max) or grounded. In the event that one of these branches is left floating or in a logic "high" the performance will degrade. It is recommended to terminate unused RF ports in 50 Ω .
- Set the control bias for the SPST switch (C_{BWRX} /pin-5) "low" during WiFi Rx only mode.
- Turn RF ON.

WiFi and Bluetooth Receive (Simultaneous Mode)

The RFFM5765Q WiFi and Bluetooth receive circuits were specifically designed to address issues of simultaneous operation. In this mode both signals can be received at the same time when the C_{BWRX} (pin-5) is set high. The typical gain for each RF path is approximately 13dB and a NF of 3dB. During simultaneous mode the active components are the LNA, the SPST switch, and only the Rx branch of the

SP3T. Refer to the logic control table for proper settings.

Simultaneous Mode Biasing Instructions

- Connect the RF input (ANT/pin-10) to a signal generator and a spectrum analyzer at the Rx (pin-3) and BT (pin-8) RF ports. A multiport VNA may be used as well.
- Turn the LNA bias ON (pin-4) and set the voltage to 3.3V.
- Set C_RX and C_BWRX high. This turns ON the receive branch of the SP3T and the SPST switch.
- The SP3T controls for the off branches (V_{REG} and C_BT) must be set to a logic “low” (0.2V max) or grounded. In the event that one of these branches is left floating or in a logic “high” the performance will degrade. It is recommended to terminate unused RF Ports in 50Ω.
- Turn RF ON.

Bluetooth Mode

The RFFM5765Q Bluetooth only mode is implemented through the SP3T switch by setting C_BT “high.” Typical insertion loss is about 1.2dB.

Bluetooth Biasing Instructions

- Connect the RF input (ANT/pin-10) to a signal generator and a spectrum analyzer at the BT RF port. A VNA may be used in place of the Sig Gen and SA.
- Set C_BT (pin-9) “high.” This turns the Bluetooth branch of the SP3T switch ON.
- The SP3T controls for the off branches (V_{REG} and C_RX) must be set to a logic “low” (0.2V max) or grounded. Do not leave floating.
- Terminate unused RF Ports in 50Ω.
- Turn RF ON

Application Circuit and Layout Recommendations

The RFFM5765Q integrates the matching networks and DC blocking capacitors for all RF ports. This greatly reduces the number of external components and layout area needed to implement this FEM. Typically only a total of four external components are required to achieve nominal performance. However, depending on board layout and the many noise signals that could potentially couple to the RFFM5765Q, additional bypassing capacitors may be required to properly filter out unwanted signals that might degrade performance.

The LNA bias components consist of an inductor and a decoupling capacitor. The inductor value is critical to optimize NF and return loss at the Rx output. For best performance and tradeoff between critical parameters such as NF, Gain, and IP3, the total inductance including board trace should be approximately 1.2nH. The 5.6kΩ series resistor for the Bluetooth control line helps to prevent unwanted signal from coupling to this pin. The resistor should be placed as close as possible to the package pin. The last component needed in the application circuit is a low frequency bypass capacitor on the V_{CC} line. In general, it is good RF practice to have proper decoupling of supply lines to filter out noise. Occasionally, depending on the level of coupling or parasitics of the board, a high frequency bypass capacitor must be added as well.

In order to optimize performance for both the transmit and receive paths, a good layout design must be implemented. In addition to designing 50Ω RF lines, proper grounding along the RF traces and on the FEM ground slug must be exercised. This will minimize coupling and provide good thermal dissipation when the PA is operating at high power. For reference, the RFMD evaluation board uses 9 thermal ground vias (hole/capture pad 12/22mil) on the ground slug. Additionally, if space permitted, V_{CC} and control lines must be isolated from each other with ground vias in between them. RFMD evaluation board gerbers are available upon request.



Contact Information

For the latest specifications, additional product information, worldwide sales and distribution locations:

Web: www.qorvo.com

Tel: 1-844-890-8163

Email: customer.support@qorvo.com

Important Notice

The information contained herein is believed to be reliable. Qorvo makes no warranties regarding the information contained herein. Qorvo assumes no responsibility or liability whatsoever for any of the information contained herein. Qorvo assumes no responsibility or liability whatsoever for the use of the information contained herein. The information contained herein is provided "AS IS, WHERE IS" and with all faults, and the entire risk associated with such information is entirely with the user. All information contained herein is subject to change without notice. Customers should obtain and verify the latest relevant information before placing orders for Qorvo products. The information contained herein or any use of such information does not grant, explicitly or implicitly, to any party any patent rights, licenses, or any other intellectual property rights, whether with regard to such information itself or anything described by such information.

X-ON Electronics

Largest Supplier of Electrical and Electronic Components

Click to view similar products for [WiFi Development Tools - 802.11 category](#):

Click to view products by [Qorvo manufacturer](#):

Other Similar products are found below :

[YSAEWIFI-1](#) [SKY65981-11EK1](#) [QPF7221PCK-01](#) [SIMSA915C-Cloud-DKL](#) [SIMSA433C-Cloud-DKL](#) [ISM43903-R48-EVB-E](#)
[QPF4206BEVB01](#) [RN-G2SDK](#) [SKY85734-11EK1](#) [SKY85735-11EK1](#) [ENW49D01AZKF](#) [ESP-LAUNCHER](#) [MIKROE-2336](#)
[EVAL_PAN1760EMK](#) [3210](#) [EVAL_PAN1026EMK](#) [ATWINC1500-XPRO](#) [2471](#) [DM990001](#) [WRL-13711](#) [2999](#) [ATWILC3000-SHLD](#)
[DFR0321](#) [TEL0118](#) [3213](#) [DFR0489](#) [WRL-13804](#) [DEV-13907](#) [UP-3GHAT-A20-0001](#) [3405](#) [TEL0078](#) [2680](#) [2702](#) [2821](#) [3044](#) [3606](#) [3653](#)
[4000](#) [4172](#) [4178](#) [4201](#) [4285](#) [4289](#) [CS-ANAVI-25](#) [CS-ANAVI-26](#) [CS-ANAVI-23](#) [CS-ANAVI-24](#) [CS-ANAVI-28](#) [CS-ANAVI-29](#) [CS-ANAVI-30](#)