

### Product Overview

The RFGA2044 is a high performance InGaP HBT MMIC amplifier. The RFGA2044's internal active bias circuitry allows the amplifier to operate directly from a 5V supply and provides stable current over temperature and process variations of the Beta. This Darlington amplifier is internally matched to 50Ω making it ideal for applications requiring small footprints and minimal external components.



SOT-89 Package

### Key Features

- Low Cost
- Broadband Gain
- Internally Matched
- Internal Active Bias
- No Dropping Resistor Required
- Single Supply 5V Operation
- HBM ESD Level >1000V

### Functional Block Diagram

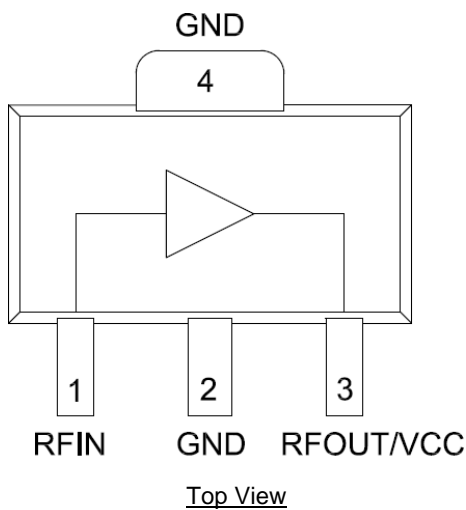

### Applications

- PA Driver Amplifier
- LO Buffer Amplifier
- Cellular, PCS, GSM, UMTS, LTE, TD\_SCDMA
- Wideband Instrumentation
- Wireless Data, Satellite Terminals

### Ordering Information

Part No.	Description
RFGA2044TR13	2,500 pieces on a 13" reel
RFGA2044 PCK-410	500–3000 MHz Evaluation Board with a 5-piece sample bag

## Absolute Maximum Ratings

Parameter	Rating
Storage Temperature	-55 to +150 °C
Device Voltage (V <sub>CC</sub> )	+6.0 V
Device Current (I <sub>CC</sub> )	130 mA
RF Input Power, CW, 2:1 Output VSWR	+20 dBm
RF Input Power, CW, 10:1 Output VSWR	+15 dBm
Junction Temperature (T <sub>J</sub> )	+150 °C

Exceeding any one or a combination of the Absolute Maximum Rating conditions may cause permanent damage to the device. Extended application of Absolute Maximum Rating conditions to the device may reduce device reliability.

## Electrical Specifications

Parameter	Conditions <sup>(1)</sup>	Min	Typ	Max	Units
<b>Linear Operation</b>					
Input Power	Standard EVB circuit without R2				
	V <sub>CC</sub> < 5.0V, Load VSWR < 2:1, R2 Open			6.0	dBm
Gain, Small Signal	850 MHz		15.3		dB
	2140 MHz	13.5	15.1	16.5	dB
	2650 MHz		15.1		dB
Input Return Loss	2140 MHz		15.0		dB
Output Return Loss			140		dB
Output P1dB	850 MHz		19.0		dBm
	2140 MHz	17.3	18.8		dBm
	2650 MHz		18.2		dBm
Output IP3 <sup>(2)</sup>	850 MHz		35.5		dBm
	2140 MHz	28.0	30.5		dBm
	2650 MHz		29.0		dBm
Bandwidth	Minimum 10 dB typical return loss		3000		MHz
Reverse Isolation	2140 MHz		19.0		dB
Noise Figure			4.3		dB
Device Quiescent Current, I <sub>CC</sub>	Pin 3		68	78	mA
Thermal Resistance, θ <sub>JC</sub>	Junction to case at quiescent state no RF		135		°C/W
<b>Saturated Operation</b>					
Input Power	With R2 5.1KΩ Pin 1 and GND lowering I <sub>CC</sub>				
	V <sub>CC</sub> < 5.0V, Load VSWR < 2:1, R2=5.1 KΩ			14	dBm
Saturated Output Power	850 MHz		19.4		dBm
	2140 MHz		19.8		dBm
	2650 MHz		19.8		dBm
Operating Current, I <sub>CC</sub>				90	mA

Notes:

1. Test conditions unless otherwise noted: V<sub>CC</sub> = +5.0V, Temp = +25 °C, 50 Ω test system
2. P<sub>OUT</sub> = 0 dBm/tone, Δf = 1 MHz

## Recommended Operating Conditions

Parameter	Min	Typ	Max	Units
Device Voltage (V <sub>CC</sub> )		+5	+5.25	V
T <sub>CASE</sub>	-40		+85	°C

Electrical specifications are measured at specified test conditions. Specifications are not guaranteed over all recommended operating conditions.

**500MHz to 3500 MHz Evaluation Board – RFGA2044PCK-410**

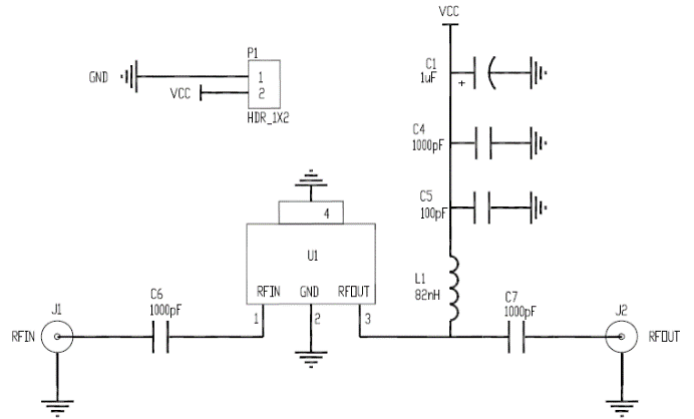
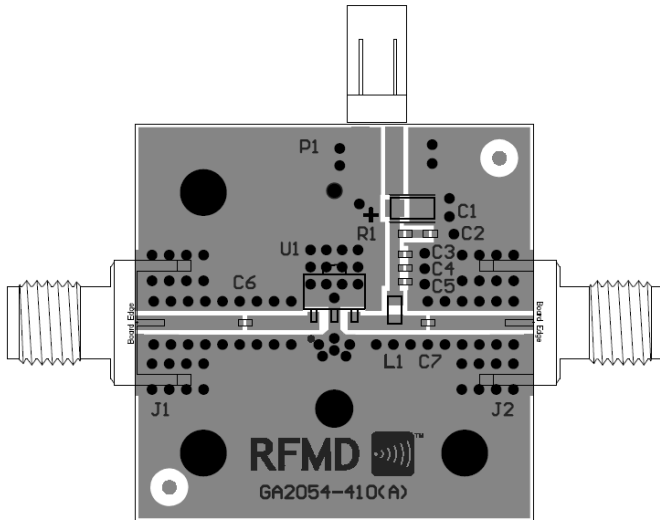

**Bill of Material – RFGA2044PCK-410**

Reference Des.	Value	Description	Manuf.	Part Number
PCB	-	Printed Circuit Board	Qorvo	-
U1	-	AMP, InGaP Darlington HBT, SOT-89	Qorvo	RFGA2044
C1	1 $\mu$ F	CAP, 1 $\mu$ F, 20%, 25V, TANT-A	AVX	TAJA105M025
C4, C6, C7	1000 pF	CAP, 1000 pF, 10%, 50V, X7R, 0402	Taiyo Yuden	RM UMK105BJ102KV-F
C5	100 pF	CAP, 100 pF, 5%, 50V, C0G, 0402	Taiyo Yuden	RM UMK105CG101JV-F
L1	82 nH	IND, 82 nH, 10%, W/W, 0805	Coilcraft	0805CS-820XKBC
J1, J2	-	CONN, SMA, END LNCH, FLT, 0.062"	Johnson	142-0701-821
P1	-	CONN, HDR, ST, PLRZD, 2-Pin, 0.100"	ITW Pancon	MPSS100-2-C

## Linear Operation Performance Plots – RFGA2044PCK-410

Test conditions unless otherwise noted:  $V_{CC} = +5V$ , 50Ω test system, Temp.=+25 °C

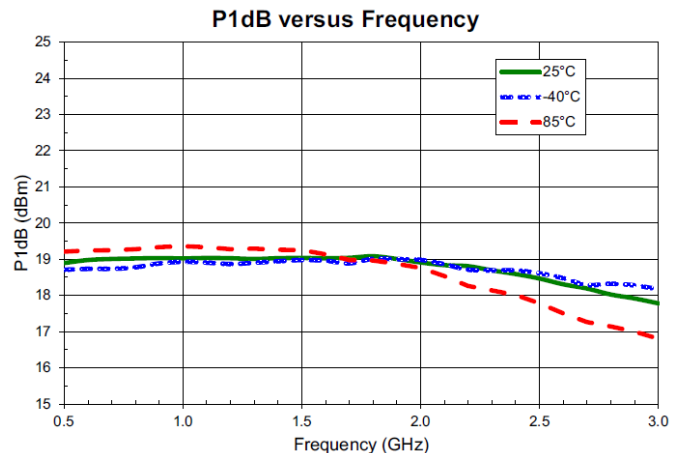
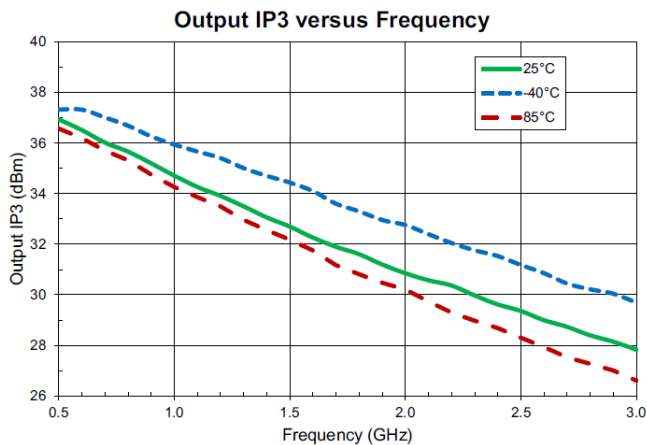
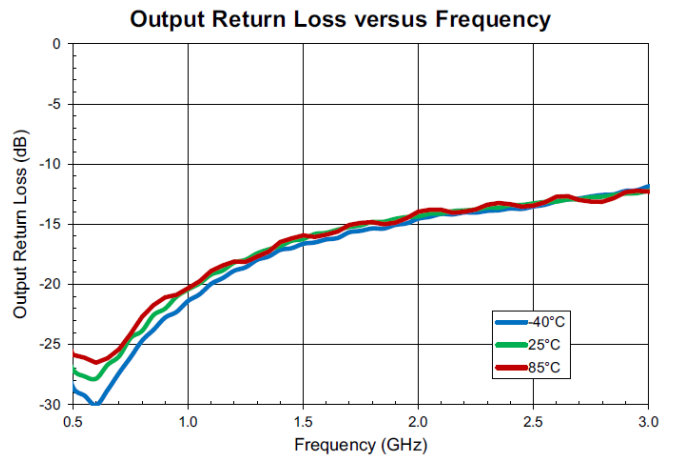
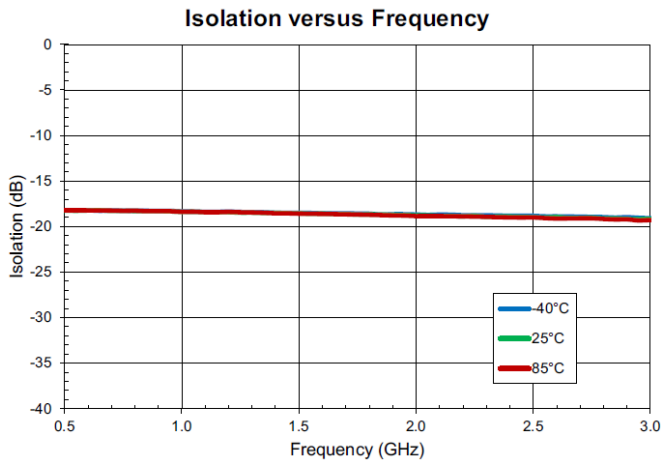
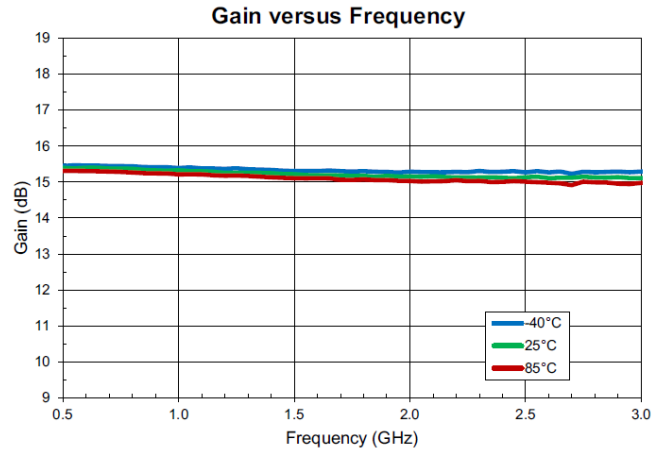
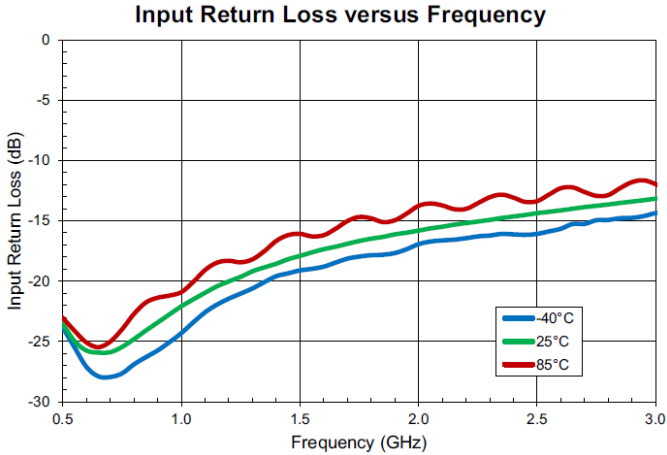

## Linear Operation Performance Plots – RFGA2044PCK-410 (continued)

Test conditions unless otherwise noted:  $V_{CC} = +5V$ ,  $50\Omega$  test system, Temp. = +25 °C

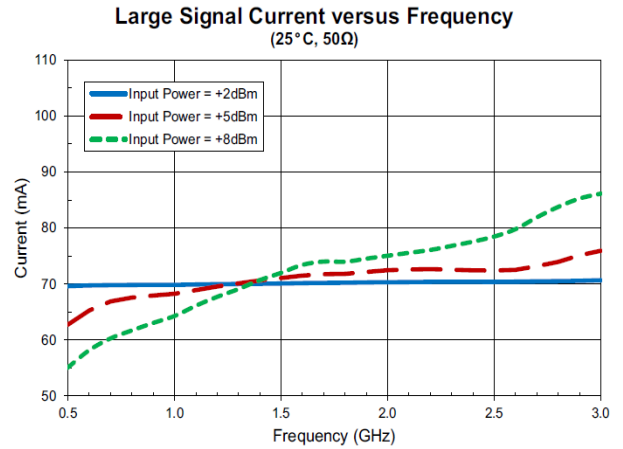
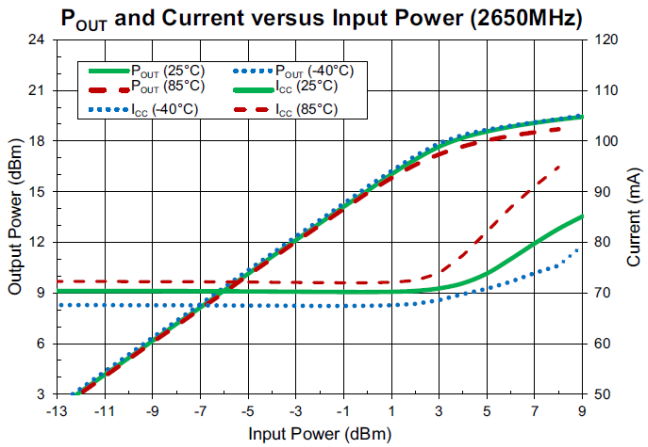
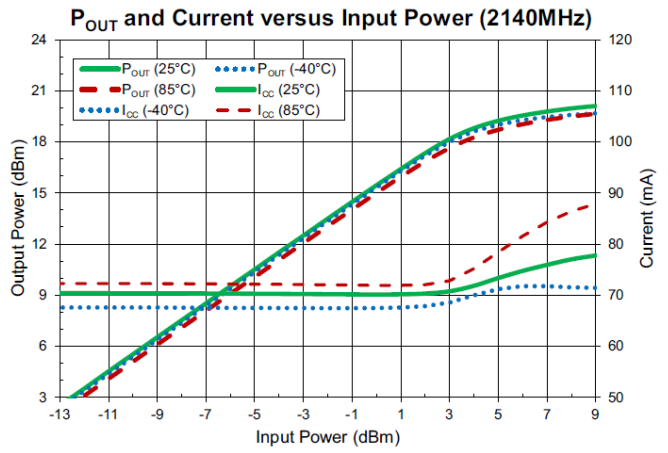
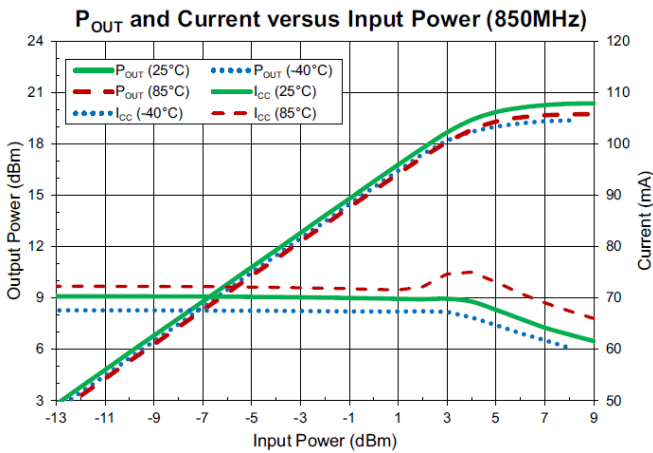
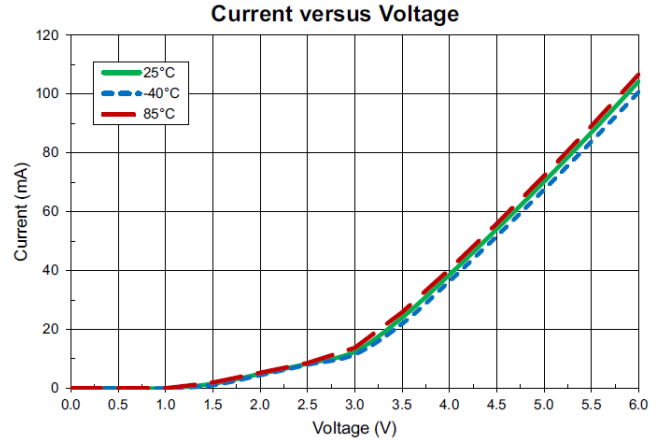
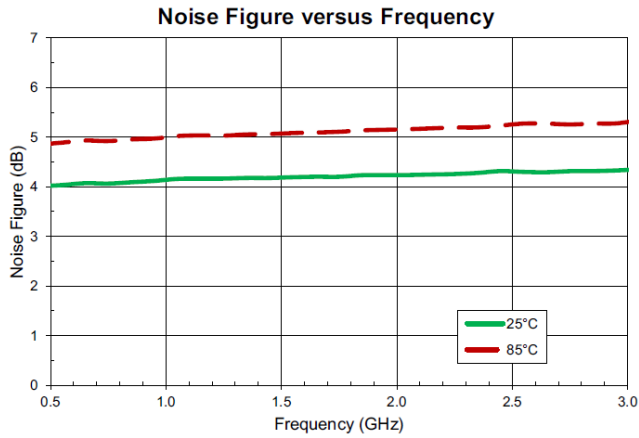

Saturated Application Board and Schematic

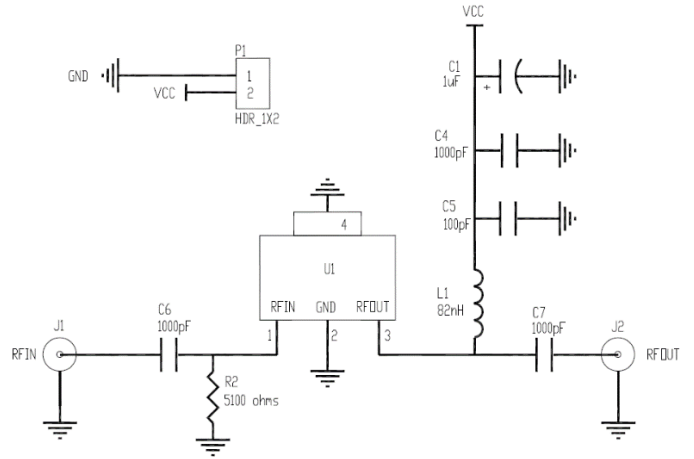
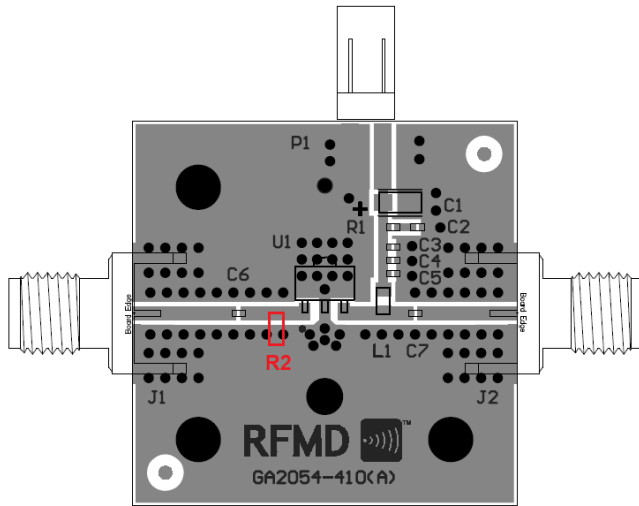

Additional resistor R2, 5.1KΩ, shunted to ground in between C6 and Pin 1

Saturated Performance Plots – with R2, 5.1KΩ

Test conditions unless otherwise noted:  $V_{CC} = +5V$ , 50 Ω test system, Temp. = +25 °C

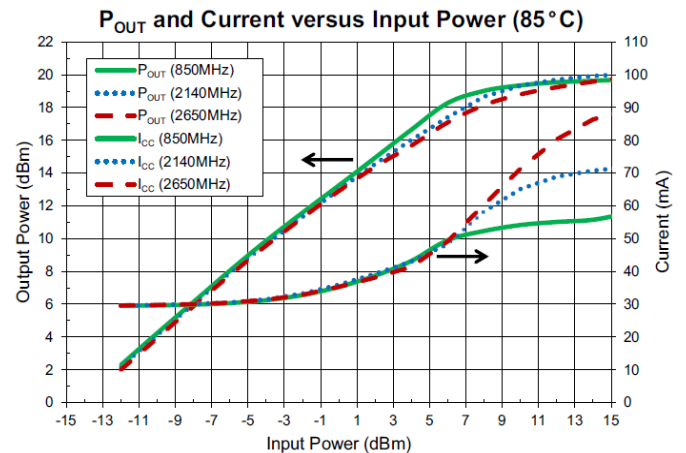
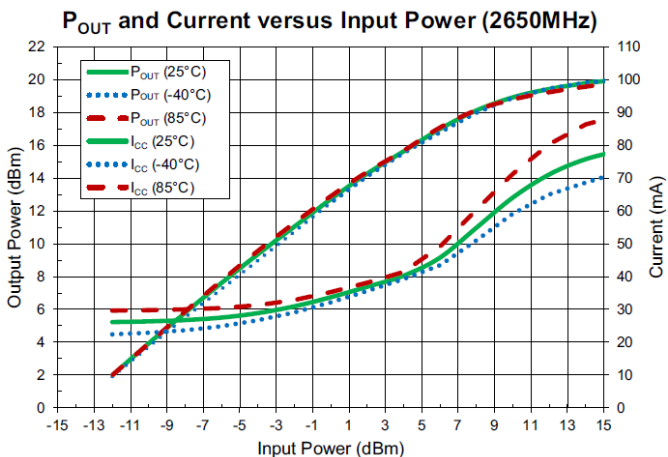
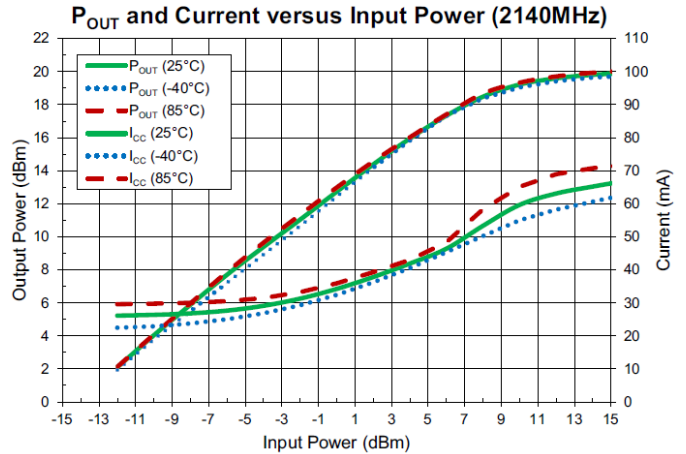
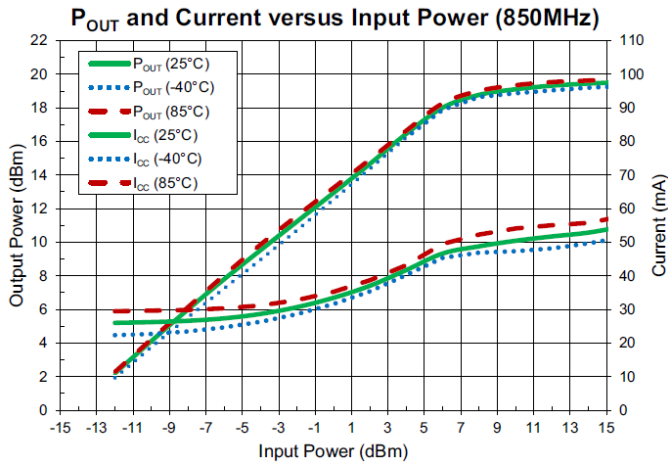

## Pad Configuration and Description

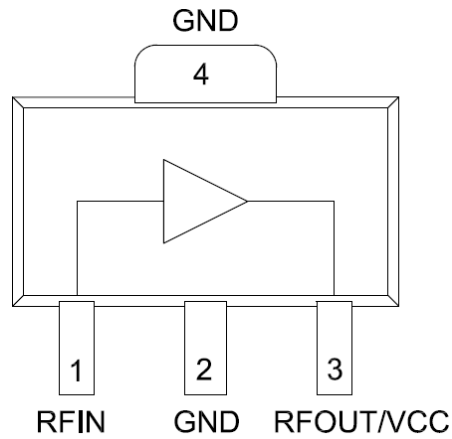

Top View

Pad No.	Label	Description
1	RFIN	RF input. External DC Block capacitor required.
3	RFOUT / VCC	RF output and DC Supply input. Device Collector, External DC Block capacitor required.
2, 4 Backside Paddle	GND	RF and DC ground. Use recommended via hole pattern to minimize inductance and thermal resistance. See PCB Mounting Pattern for suggested footprint.

## Package Marking and Dimensions

Marking: Part Number – GA2044  
Trace Code – Assigned by sub-contractor

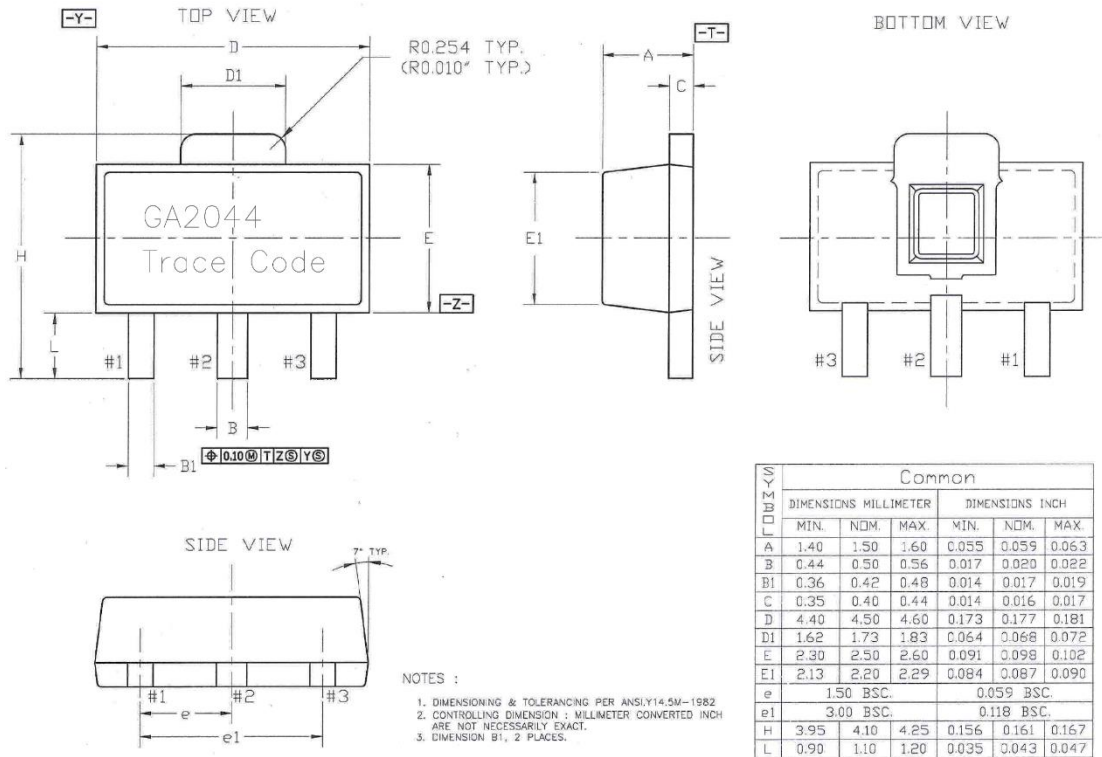

- Notes:
- All dimensions are in millimeters. Angles are in degrees.
  - The terminal #1 identifier and terminal numbering conform to JESD 95-1 SPP-012.

## PCB Mounting Pattern

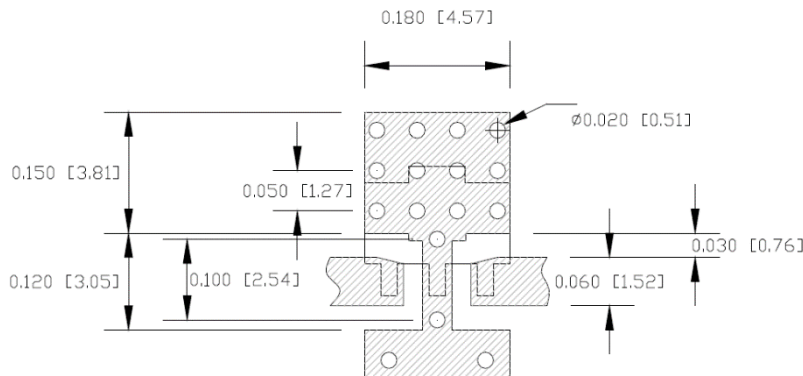

- Notes:
- All dimensions are in millimeters. Angles are in degrees.
  - Use 1 oz. copper minimum for top and bottom layer metal.
  - Via holes are required under the backside paddle of this device for proper RF/DC grounding and thermal dissipation. We recommend a 0.35mm (#80/.0135") diameter bit for drilling via holes and a final plated thru diameter of 0.25 mm (0.01").
  - Ensure good package backside paddle solder attach for reliable operation and best electrical performance.



**Tape and Reel Information – Carrier and Cover Tape Dimensions**

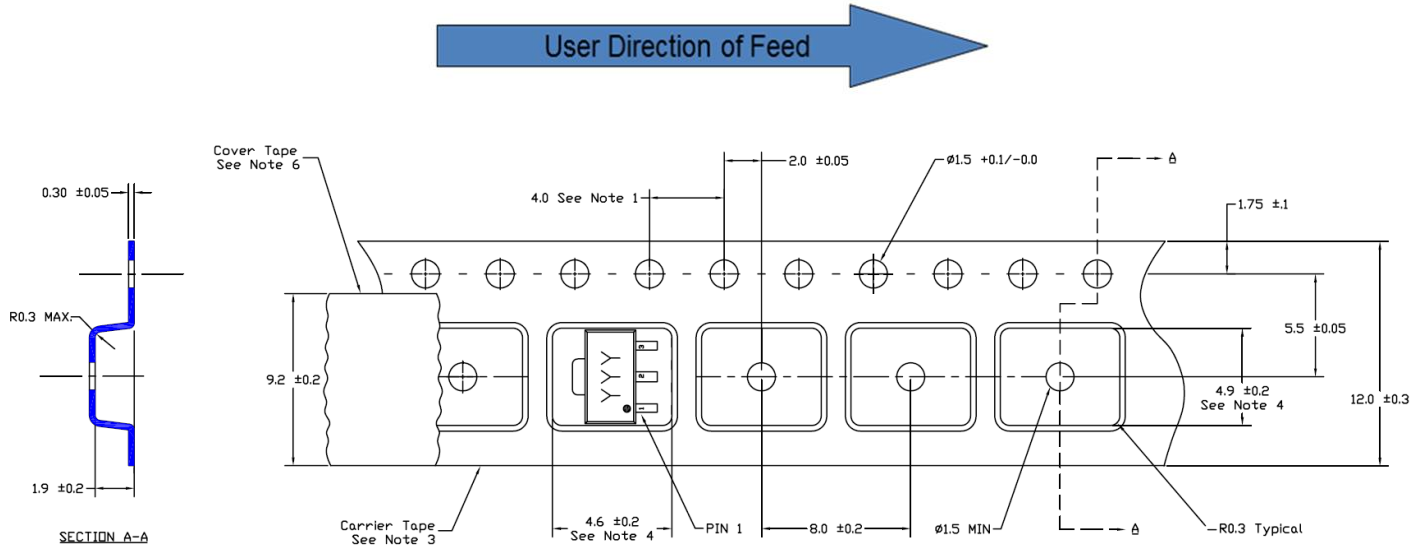

- 1. 10 sprocket hole pitch cumulative tolerance
- 2. Camber not to exceed 1mm in 100mm
- 3. Material: Black Conductive Polystyrene
- 4. Measured on a plane 0.3mm above the bottom of the pocket
- 5. Measured from a plane on the inside bottom of the pocket to the top surface of the carrier.
- 6. Material: Antistatic Polyester Film

Feature	Measure	Symbol	Size (in)	Size (mm)
Cavity	Length	A0	0.181	4.60
	Width	B0	0.193	4.90
	Depth	K0	0.075	1.90
	Pitch	P1	0.315	8.00
Centerline Distance	Cavity to Perforation - Length Direction	P2	0.079	2.00
	Cavity to Perforation - Width Direction	F	0.217	5.50
Cover Tape	Width	C	0.362	9.20
Carrier Tape	Width	W	0.472	12.0

**Tape and Reel Information – Reel Dimensions**

Standard T/R size = 2,500 pieces on a 13" reel.

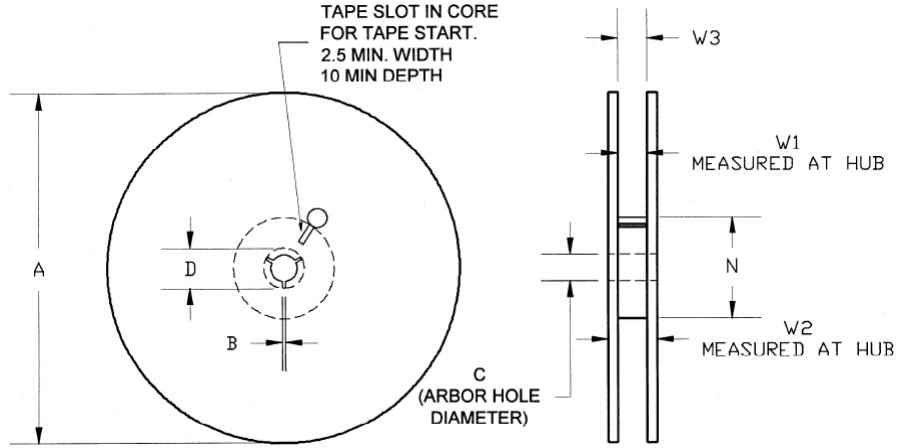

Feature	Measure	Symbol	Size (in)	Size (mm)
Flange	Diameter	A	12.992	330.0
	Thickness	W2	0.717	18.2
	Space Between Flange	W1	0.504	12.8
Hub	Outer Diameter	N	4.016	102.0
	Arbor Hole Diameter	C	0.512	13.0
	Key Slit Width	B	0.079	2.0
	Key Slit Diameter	D	0.787	20.0

**Tape and Reel Information – Tape Length and Label Placement**



- Notes:
1. Empty part cavities at the trailing and leading ends are sealed with cover tape. See EIA 481-1-A.
  2. Labels are placed on the flange opposite the sprockets in the carrier tape.

## Handling Precautions

Parameter	Rating	Standard
ESD – Human Body Model (HBM)	Class 1C	ESDA / JEDEC JS-001-2012
ESD – Charged Device Model (CDM)	Class C3	ESDA / JEDEC JS-002-2012
MSL – Moisture Sensitivity Level	Level 3	IPC/JEDEC J-STD-020



Caution!  
 ESD-Sensitive Device

## Solderability

Compatible with both lead-free (260°C max. reflow temp.) and tin/lead (245°C max. reflow temp.) soldering processes. Solder profiles available upon request.

Contact plating: NiPdAu

## RoHS Compliance

This part is compliant with 2011/65/EU RoHS directive (Restrictions on the Use of Certain Hazardous Substances in Electrical and Electronic Equipment) as amended by Directive 2015/863/EU.

This product also has the following attributes:

- Lead Free
- Halogen Free (Chlorine, Bromine)
- Antimony Free
- TBBP-A (C<sub>15</sub>H<sub>12</sub>Br<sub>4</sub>O<sub>2</sub>) Free
- PFOS Free
- SVHC Free



## Contact Information

For the latest specifications, additional product information, worldwide sales and distribution locations:

**Web:** [www.qorvo.com](http://www.qorvo.com)

**Tel:** 1-844-890-8163

**Email:** [customer.support@qorvo.com](mailto:customer.support@qorvo.com)

## Important Notice

The information contained herein is believed to be reliable; however, Qorvo makes no warranties regarding the information contained herein and assumes no responsibility or liability whatsoever for the use of the information contained herein. All information contained herein is subject to change without notice. Customers should obtain and verify the latest relevant information before placing orders for Qorvo products. The information contained herein or any use of such information does not grant, explicitly or implicitly, to any party any patent rights, licenses, or any other intellectual property rights, whether with regard to such information itself or anything described by such information. **THIS INFORMATION DOES NOT CONSTITUTE A WARRANTY WITH RESPECT TO THE PRODUCTS DESCRIBED HEREIN, AND QORVO HEREBY DISCLAIMS ANY AND ALL WARRANTIES WITH RESPECT TO SUCH PRODUCTS WHETHER EXPRESS OR IMPLIED BY LAW, COURSE OF DEALING, COURSE OF PERFORMANCE, USAGE OF TRADE OR OTHERWISE, INCLUDING THE IMPLIED WARRANTIES OF MERCHANTABILITY AND FITNESS FOR A PARTICULAR PURPOSE.**

Without limiting the generality of the foregoing, Qorvo products are not warranted or authorized for use as critical components in medical, life-saving, or life-sustaining applications, or other applications where a failure would reasonably be expected to cause severe personal injury or death.

Copyright 2021 © Qorvo, Inc. | Qorvo is a registered trademark of Qorvo, Inc.

## X-ON Electronics

Largest Supplier of Electrical and Electronic Components

*Click to view similar products for [RF Amplifier](#) category:*

*Click to view products by [Qorvo](#) manufacturer:*

Other Similar products are found below :

[A82-1](#) [BGA622H6820XTSA1](#) [BGA 728L7 E6327](#) [BGB719N7ESDE6327XTMA1](#) [HMC397-SX](#) [HMC405](#) [HMC561-SX](#) [HMC8120-SX](#)  
[HMC8121-SX](#) [HMC-ALH382-SX](#) [HMC-ALH476-SX](#) [SE2433T-R](#) [SMA3101-TL-E](#) [SMA39](#) [A66-1](#) [A66-3](#) [A67-1](#) [A81-2](#) [LX5535LQ](#)  
[LX5540LL](#) [MAAM02350](#) [HMC3653LP3BETR](#) [HMC549MS8GETR](#) [HMC-ALH435-SX](#) [SMA101](#) [SMA32](#) [SMA411](#) [SMA531](#)  
[SST12LP19E-QX6E](#) [WPM0510A](#) [HMC5929LS6TR](#) [HMC5879LS7TR](#) [HMC1126](#) [HMC1087F10](#) [HMC1086](#) [HMC1016](#) [SMA1212](#)  
[MAX2689EWS+T](#) [MAAMSS0041TR](#) [MAAM37000-A1G](#) [LTC6430AIUF-15#PBF](#) [SMA70-2](#) [SMA4011](#) [A231](#) [HMC-AUH232](#) [LX5511LQ](#)  
[LX5511LQ-TR](#) [HMC7441-SX](#) [HMC-ALH310](#) [XD1001-BD-000V](#)