



Package: SOT-115J



Features

- Excellent Linearity
- Superior Return Loss Performance
- Extremely Low Distortion
- Optimal Reliability
- Suitable for PAL D and Flat NTSC Loading
- Unconditionally Stable Under all Terminations
- High Output Capability
- 420mA typ. at 24VDC

Applications

- 40MHz to 1003MHz CATV Amplifier System

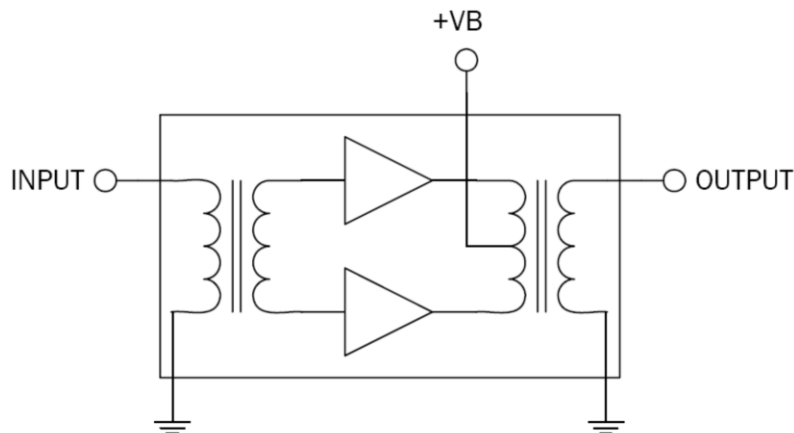

Product Description

The RFPD9950 is a Hybrid Power Doubler amplifier module. RFPD9950 has the best power consumption performance in its class. The part employs GaAs MESFET die, GaAs pHEMT die and, GaN HEMT die. RFPD9950 is designed to operate from 40MHz to 1003MHz. It provides excellent linearity and superior return loss performance with low noise. The product is packaged in SOT-115J and uses the latest GaN technology for the output stage.

Optimum Technology Matching® Applied

- | | | | |
|---|--------------------------------------|--|--|
| <input type="checkbox"/> GaAs HBT | <input type="checkbox"/> SiGe BiCMOS | <input checked="" type="checkbox"/> GaAs pHEMT | <input checked="" type="checkbox"/> GaN HEMT |
| <input checked="" type="checkbox"/> GaAs MESFET | <input type="checkbox"/> Si BiCMOS | <input type="checkbox"/> Si CMOS | <input type="checkbox"/> RF MEMS |
| <input type="checkbox"/> InGaP HBT | <input type="checkbox"/> SiGe HBT | <input type="checkbox"/> Si BJT | <input type="checkbox"/> LDMOS |

Absolute Maximum Ratings

Parameter	Rating	Unit
RF Input Voltage (single tone; on evaluation board)	70	dBmV
DC Supply Over-Voltage (5 minutes)	30	V
Storage Temperature	-40 to +100	°C
Operating Mounting Base Temperature	-30 to +100	°C



Caution! ESD sensitive device.

Exceeding any one or a combination of the Absolute Maximum Rating conditions may cause permanent damage to the device. Extended application of Absolute Maximum Rating conditions to the device may reduce device reliability. Specified typical performance or functional operation of the device under Absolute Maximum Rating conditions is not implied.

RoHS status based on EU Directive 2002/95/EC (at time of this document revision).

The information in this publication is believed to be accurate and reliable. However, no responsibility is assumed by RF Micro Devices, Inc. ("RFMD") for its use, nor for any infringement of patents, or other rights of third parties, resulting from its use. No license is granted by implication or otherwise under any patent or patent rights of RFMD. RFMD reserves the right to change component circuitry, recommended application circuitry and specifications at any time without prior notice.

Parameter	Specification			Unit	Condition
	Min.	Typ.	Max.		
Overall					V+= 24V; TMB=30°C; ZS=ZL=75Ω
Power Gain		23.3		dB	f=50MHz
		24.7			f=870MHz
	24.0	25.0	26.0	dB	f=1003MHz
Slope ^[1]	0.5		2.0	dB	f=40MHz to 1003MHz
Flatness of Frequency Response			0.8	dB	f=40MHz to 1003MHz
Input Return Loss	-20			dB	f=40MHz to 320MHz
	-18			dB	f=320MHz to 640MHz
	-17			dB	f=640MHz to 870MHz
	-16			dB	f=870MHz to 1003MHz
Output Return Loss	-20			dB	f=40MHz to 320MHz
	-18			dB	f=320MHz to 640MHz
	-17			dB	f=640MHz to 870MHz
	-16			dB	f=870MHz to 1003MHz
Noise Figure		5.0	5.5	dB	f=50MHz to 1003MHz
Total Current Consumption (DC)		420.0	450.0	mA	
Distortion					V+= 24V; TMB=30°C; ZS=ZL=75Ω, PAL D Raster
CTB ^[4]		-66	-62	dBc	V ₀ =48dBmV at 862MHz, flat, 98 analog channels ^[2]
XMOD ^[5]		-68		dBc	V ₀ =48dBmV at 862MHz, flat, 98 analog channels ^[2]
CSO ^[6]		-65	-62	dBc	V ₀ =48dBmV at 862MHz, flat, 98 analog channels ^[2]
Distortion					V+= 24V; TMB=30°C; ZS=ZL=75Ω, NTSC Raster
CTB ^[4]		-75		dBc	V ₀ =56.4dBmV at 1000MHz, 13.4dB extrapolated tilt, 79 analog channels plus 75 digital channels (-6dB offset) ^[3]
XMOD ^[5]		-70		dBc	V ₀ =56.4dBmV at 1000MHz, 13.4dB extrapolated tilt, 79 analog channels plus 75 digital channels (-6dB offset) ^[3]
CSO ^[6]		-79		dBc	V ₀ =56.4dBmV at 1000MHz, 13.4dB extrapolated tilt, 79 analog channels plus 75 digital channels (-6dB offset) ^[3]
CIN ^[7]		66		dB	V ₀ =56.4dBmV at 1000MHz, 13.4dB extrapolated tilt, 79 analog channels plus 75 digital channels (-6dB offset) ^[3]

- The slope is defined as the difference between the gain at the start frequency and the gain at the stop frequency.
- 98 analog channels, PAL D raster: 47.25MHz to 862.25MHz, 48dBmV flat output level
- 79 analog channels, NTSC frequency raster: 55.25MHz to 547.25MHz, +43dBmV to +50dBmV tilted output level, plus 75 digital channels, -6dB offset relative to the equivalent analog carrier.
- Composite Triple Beat (CTB) - The CTB parameter is defined by the NCTA.
- Cross Modulation (XMOD) - Cross modulation (XMOD) is measured at baseband (selective voltmeter method), referenced to 100% modulation of the carrier being tested.
- Composite Second Order (CSO) - The CSO parameter (both sum and difference products) is defined by the NCTA.
- Carrier to Intermodulation Noise (CIN) - The CIN parameter is defined by ANSI/SCTE 17 (Test procedure for carrier to noise).

Package Drawing

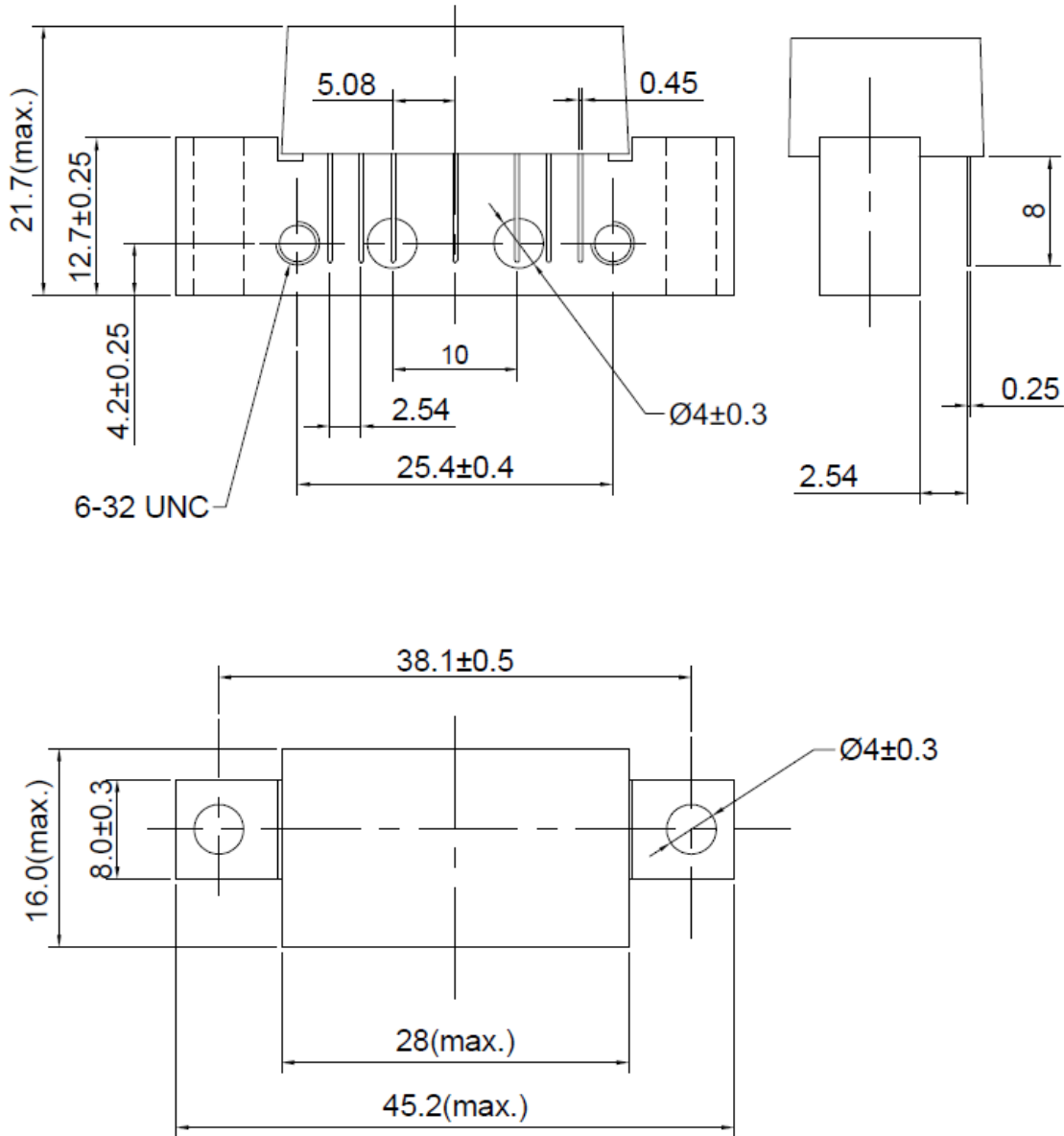

Unit: mm

Pinning:

1	2	3	4	5	6	7	8	9
INPUT	GND	GND		+VB		GND	GND	OUTPUT

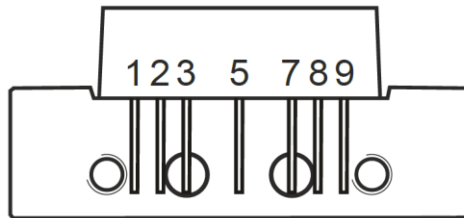

X-ON Electronics

Largest Supplier of Electrical and Electronic Components

Click to view similar products for [RF Amplifier](#) category:

Click to view products by [Qorvo](#) manufacturer:

Other Similar products are found below :

[A82-1](#) [BGA622H6820XTSA1](#) [BGA 728L7 E6327](#) [BGB719N7ESDE6327XTMA1](#) [HMC397-SX](#) [HMC405](#) [HMC561-SX](#) [HMC8120-SX](#)
[HMC8121-SX](#) [HMC-ALH382-SX](#) [HMC-ALH476-SX](#) [SE2433T-R](#) [SMA3101-TL-E](#) [SMA39](#) [A66-1](#) [A66-3](#) [A67-1](#) [LX5535LQ](#) [LX5540LL](#)
[MAAM02350](#) [HMC3653LP3BETR](#) [HMC549MS8GETR](#) [HMC-ALH435-SX](#) [SMA101](#) [SMA32](#) [SMA411](#) [SMA531](#) [SST12LP17E-XX8E](#)
[SST12LP19E-QX6E](#) [WPM0510A](#) [HMC5929LS6TR](#) [HMC5879LS7TR](#) [HMC1126](#) [HMC1087F10](#) [HMC1086](#) [HMC1016](#) [SMA1212](#)
[MAX2689EWS+T](#) [MAAMSS0041TR](#) [MAAM37000-A1G](#) [LTC6430AIUF-15#PBF](#) [CHA5115-QDG](#) [SMA70-2](#) [SMA4011](#) [A231](#) [HMC-](#)
[AUH232](#) [LX5511LQ](#) [LX5511LQ-TR](#) [HMC7441-SX](#) [HMC-ALH310](#)