

RFPP3180

GaAs Push Pull Hybrid
45MHz to 1218MHz

The RFPP3180 is a Hybrid Push Pull amplifier module. The part employs GaAs die and is operated from 45MHz to 1218MHz. It provides excellent linearity and superior return loss performance with low noise and optimal reliability.

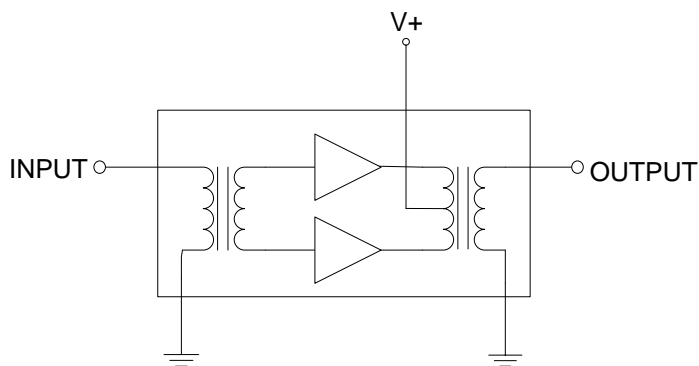

Package: SOT-115J

Features

- Excellent Linearity
- Superior Return Loss Performance
- Extremely Low Distortion
- Optimal Reliability
- Extremely Low Noise
- Unconditionally Stable Under All Terminations
- 34.0dB Min. Gain at 1218MHz
- 280mA Max. at 24V_{DC}

Applications

- 45MHz to 1.218GHz CATV Amplifier Systems
- DOCSIS 3.1 Applications

Ordering Information

RFPP3180 Box with 50 Pieces

Absolute Maximum Ratings

Parameter	Rating	Unit
RF Input Voltage (single tone)	70	dBmV
DC Supply Over-Voltage (5 minutes)	30	V
Storage Temperature	-40 to +100	°C
Operating Mounting Base Temperature	-30 to +85	°C



Caution! ESD sensitive device.



RoHS (Restriction of Hazardous Substances): Compliant per EU Directive 2011/65/EU.

Exceeding any one or a combination of the Absolute Maximum Rating conditions may cause permanent damage to the device. Extended application of Absolute Maximum Rating conditions to the device may reduce device reliability. Specified typical performance or functional operation of the device under Absolute Maximum Rating conditions is not implied.

Nominal Operating Parameters

Parameter	Specification			Unit	Condition
	Min	Typ	Max		
General Performance					V+ = 24V; T_{MB} = 30°C; Z_S = Z_L = 75Ω
Power Gain		33.5		dB	f = 50MHz
	34.0		36.0	dB	f = 1218MHz
Slope ^[1]	0.5	1.5	2.5	dB	f = 45MHz to 1218MHz
Flatness of Frequency Response			1.0	dB	f = 45MHz to 1218MHz
Input Return Loss	20.0			dB	f = 45MHz to 160MHz
	17.0			dB	f = 160MHz to 870MHz
	16.0			dB	f = 870MHz to 1218MHz
Output Return Loss	20.0			dB	f = 45MHz to 160MHz
	17.0			dB	f = 160MHz to 870MHz
	16.0			dB	f = 870MHz to 1000MHz
	15.0			dB	f = 1000MHz to 1218MHz
Noise Figure			4.5	dB	f = 50MHz to 1218MHz
Total Current Consumption (DC)		240.0	280.0	mA	
Distortion Data 40MHz to 550MHz					V+ = 24V; T_{MB} = 30°C; Z_S = Z_L = 75Ω
CTB		-66	-62	dBc	V _O = 46dBmV, flat, 79 analog channels plus 75 digital channels (-6dB offset) ^{[2][4]}
XMOD		-62	-58	dBc	
CSO		-72	-68	dBc	
CIN	60	64		dB	
Distortion Data 40MHz to 550MHz					V+ = 24V; T_{MB} = 30°C; Z_S = Z_L = 75Ω
CTB		-69		dBc	V _O = 45dBmV, flat, 79 analog channels plus 111 digital channels (-6dB offset) ^{[3][4]}
XMOD		-64		dBc	
CSO		-72		dBc	
CIN		65		dB	

1. The slope is defined as the difference between the gain at the start frequency and the gain at the stop frequency.

2. 79 analog channels, NTSC frequency raster: 55.25MHz to 745.25MHz, +46dBmV flat output level, plus 75 digital channels, -6dB offset relative to the equivalent analog carrier.

3. 79 analog channels, NTSC frequency raster: 55.25MHz to 547.25MHz, +45dBmV flat output level, plus 111 digital channels, -6dB offset relative to the equivalent analog carrier.

4. Composite Second Order (CSO) - The CSO parameter (both sum and difference products) is defined by the NCTA.

Composite Triple Beat (CTB) - The CTB parameter is defined by the NCTA.

Cross Modulation (XMOD) - Cross modulation (XMOD) is measured at baseband (selective voltmeter method), referenced to 100% modulation of the carrier being tested.

Carrier to Intermodulation Noise (CIN) - The CIN parameter is defined by ANSI/SCTE 17 (Test procedure for carrier to noise).

Package Drawing (Dimensions in millimeters)

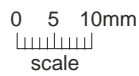
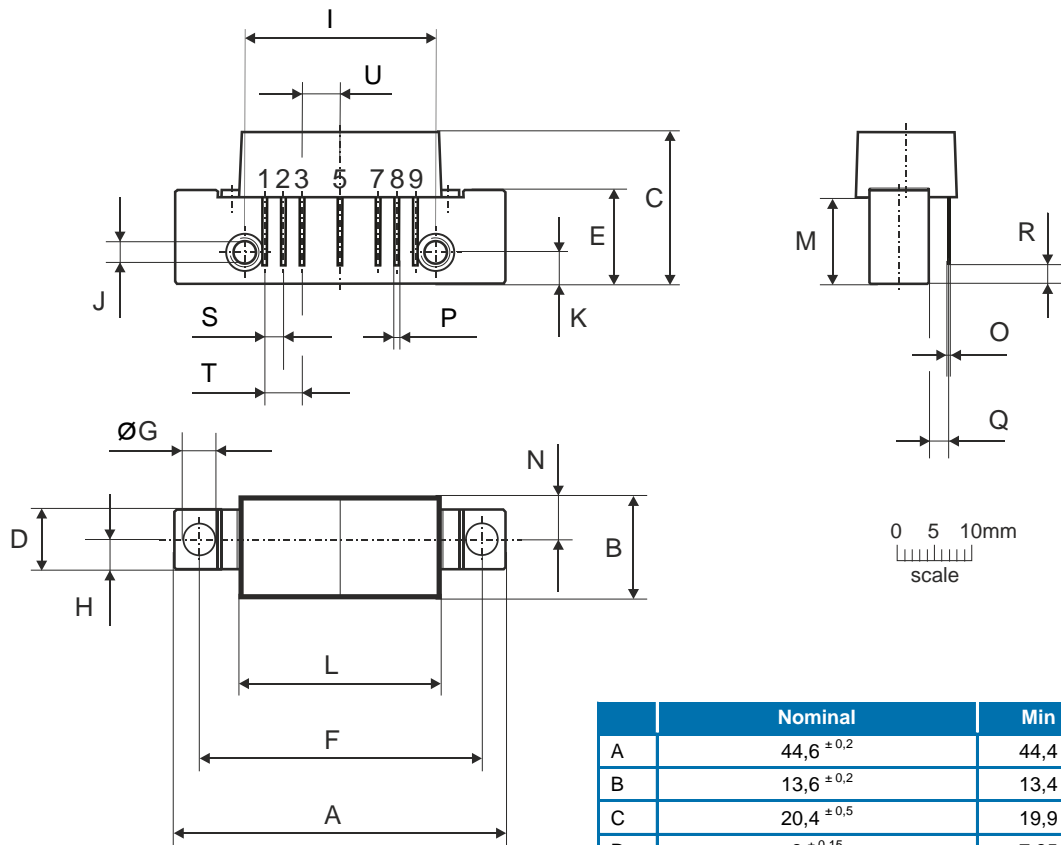

Notes:

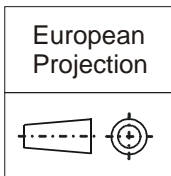

Pinning:

Pin	Name
1	Input
2-3	GND
4	
5	V+
6	
7-8	GND
9	Output

	Nominal	Min	Max
A	44,6 ±0,2	44,4	44,8
B	13,6 ±0,2	13,4	13,8
C	20,4 ±0,5	19,9	20,9
D	8 ±0,15	7,85	8,15
E	12,6 ±0,15	12,45	12,75
F	38,1 ±0,2	37,9	38,3
G	4 +0,2/-0,05	3,95	4,2
H	4 ±0,2	3,8	4,2
I	25,4 ±0,2	25,2	25,6
J	UNC 6-32	-	-
K	4,2 ±0,2	4,0	4,4
L	27,2 ±0,2	27,0	27,4
M	11,6 ±0,5	11,1	12,1
N	5,8 ±0,4	5,4	6,2
O	0,25 ±0,02	0,23	0,27
P	0,45 ±0,03	0,42	0,48
Q	2,54 ±0,3	2,24	2,84
R	2,54 ±0,5	2,04	3,04
S	2,54 ±0,25	2,29	2,79
T	5,08 ±0,25	4,83	5,33
U	5,08 ±0,25	4,83	5,33

X-ON Electronics

Largest Supplier of Electrical and Electronic Components

Click to view similar products for [RF Amplifier](#) category:

Click to view products by [Qorvo](#) manufacturer:

Other Similar products are found below :

[A82-1](#) [BGA622H6820XTSA1](#) [BGA 728L7 E6327](#) [BGB719N7ESDE6327XTMA1](#) [HMC397-SX](#) [HMC405](#) [HMC561-SX](#) [HMC8120-SX](#)
[HMC8121-SX](#) [HMC-ALH382-SX](#) [HMC-ALH476-SX](#) [SE2433T-R](#) [SMA3101-TL-E](#) [SMA39](#) [A66-1](#) [A66-3](#) [A67-1](#) [LX5535LQ](#) [LX5540LL](#)
[MAAM02350](#) [HMC3653LP3BETR](#) [HMC549MS8GETR](#) [HMC-ALH435-SX](#) [SMA101](#) [SMA32](#) [SMA411](#) [SMA531](#) [SST12LP17E-XX8E](#)
[SST12LP19E-QX6E](#) [WPM0510A](#) [HMC5929LS6TR](#) [HMC5879LS7TR](#) [HMC1126](#) [HMC1087F10](#) [HMC1086](#) [HMC1016](#) [SMA1212](#)
[MAX2689EWS+T](#) [MAAMSS0041TR](#) [MAAM37000-A1G](#) [LTC6430AIUF-15#PBF](#) [CHA5115-QDG](#) [SMA70-2](#) [SMA4011](#) [A231](#) [HMC-](#)
[AUH232](#) [LX5511LQ](#) [LX5511LQ-TR](#) [HMC7441-SX](#) [HMC-ALH310](#)