



TGA2976-SM

0.1 – 3.0 GHz 10W GaN Power Amplifier

Product Overview

Qorvo's TGA2976-SM is a wideband cascode amplifier fabricated on Qorvo's production 0.25um GaN on SiC process. The cascode configuration offers exceptional wideband performance as well as supporting 40 V operation. The TGA2976-SM operates from 0.1 - 3.0 GHz and provides greater than 10 W of saturated output power with greater than 13 dB of large signal gain and greater than 38% power-added efficiency.

The TGA2976-SM is available in a low-cost, surface mount 14 lead 4x4 Air Cavity laminate package. It is ideally suited to support both radar and communication applications across defense and commercial markets as well as electronic warfare. The TGA2976-SM is fully matched to 50 Ω at both RF ports allowing for simple system integration. DC blocks are required on both RF ports and the drain voltage must be injected through an off chip bias-tee on the RF output port.

Lead-free and RoHS compliant.

Functional Block Diagram

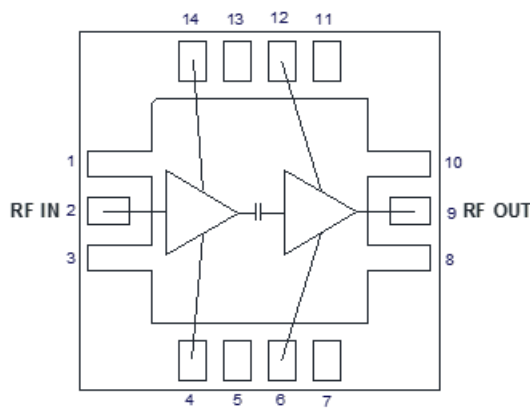

Top View

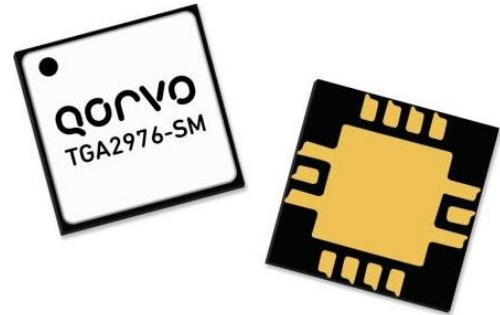

AC-QFN 4x4 mm 14L

Key Features

- Frequency Range: 0.1 – 3.0 GHz
- PSAT: >40 dBm at $P_{IN} = 27$ dBm
- PAE: 48% @ mid-band
- Large Signal Gain: >13 dB
- Small Signal Gain: >20 dB
- Bias: $V_D = 40$ V, $I_{DQ} = 360$ mA
- Wideband Flat Gain and Power
- Package Dimensions: 4.0 x 4.0 x 1.64 mm

Applications

- Commercial and military radar
- Communications
- Electronic Warfare

Ordering Information

Part No.	Description
TGA2976-SM	0.1-3.0 GHz 10 W GaN Power Amplifier
TGA2976-SM EVB	TGA2976-SM Evaluation Board

Absolute Maximum Ratings

Parameter	Rating
Drain Voltage (V_D)	80 V
Gate Voltage Range (V_{G1})	-8 to 0 V
Gate Voltage Range (V_{G2})	0 to 40 V
Drain Current (I_D)	760 mA
Gate Current (I_{G1})	See plot on pg. 3
Gate Current (I_{G2})	See plot on pg. 3
Power Dissipation (P_{DISS}), 85°C	28 W
Input Power (P_{IN}), CW, 50 Ω , 85°C,	33 dBm
Input Power (P_{IN}), CW, VSWR 3:1, $V_D = 40V$, 85°C	33 dBm
Mounting Temperature	260°C
Storage Temperature	-55 to 150°C

Exceeding any one or a combination of the Absolute Maximum Rating conditions may cause permanent damage to the device. Extended application of Absolute Maximum Rating conditions to the device may reduce device reliability.

Recommended Operating Conditions

Parameter	Value
Drain Voltage (V_D)	40 V
Drain Current (I_{DQ})	360 mA
Gate Voltage Range (V_{G1})	-2.8 to -2.0 V
Gate Voltage (V_{G2})	+17.7 V (Typ.)

Electrical specifications are measured at specified test conditions. Specifications are not guaranteed over all recommended operating conditions.

Electrical Specifications

Parameter	Conditions ⁽¹⁾	Min	Typ	Max	Units
Operational Frequency Range		0.1		3.0	GHz
Small Signal Gain			> 20		dB
Input Return Loss			> 5		dB
Output Return Loss			> 9		dB
Output Power	$P_{IN} = 27$ dBm		> 40		dBm
Power Added Efficiency	$P_{IN} = 27$ dBm, mid-band		48		%
3rd Order Intermodulation	120 mA, $P_{OUT}/tone = 28$ dBm		-30		dBc
5th Order Intermodulation	120 mA, $P_{OUT}/tone = 28$ dBm		-38		dBc
Small Signal Gain Temperature Coefficient			-0.03		dB/°C
Output Power Temperature Coefficient			-0.009		dBm/°C
Recommended Operating Voltage			40	50	V

Notes:

1. Test conditions unless otherwise noted: 25°C, $V_D = 40$ V, $I_{DQ} = 360$ mA, $V_{G1} = -2.4$ V, $V_{G2} = +17.7$ V

Thermal and Reliability Information

Parameter	Test Conditions	Value	Units
Thermal Resistance (θ_{JC}) ⁽¹⁾	$T_{base} = 85\text{ }^{\circ}\text{C}$, $V_D^{(2)} = 40\text{ V (CW)}$, $I_{DQ} = 360\text{ mA}$,	3.55	$^{\circ}\text{C/W}$
Channel Temperature, T_{CH} (Under RF) ³	$I_{D_Drive} = 655\text{ mA}$, $P_{IN} = 27\text{ dBm}$, $P_{OUT} = 40\text{ dBm}$, $P_{DISS} = 17.4\text{ W}$		
Thermal Resistance (θ_{JC}) ⁽¹⁾	$T_{base} = 85\text{ }^{\circ}\text{C}$, $V_D^{(2)} = 50\text{ V (CW)}$, $I_{DQ} = 360\text{ mA}$,	3.70	$^{\circ}\text{C/W}$
Channel Temperature, T_{CH} (Under RF) ³	$I_{D_Drive} = 655\text{ mA}$, $P_{IN} = 27\text{ dBm}$, $P_{OUT} = 40\text{ dBm}$, $P_{DISS} = 23.6\text{ W}$		

Notes:

1. Thermal resistance measured at back of package.
2. The drain voltage for Cascode amplifier transistor is $\frac{1}{2}$ of V_D
3. IR scan equivalent. Refer to the following document: [GaN Device Channel Temperature, Thermal Resistance, and Reliability Estimates](#)

Power Dissipation and Maximum Gate Current

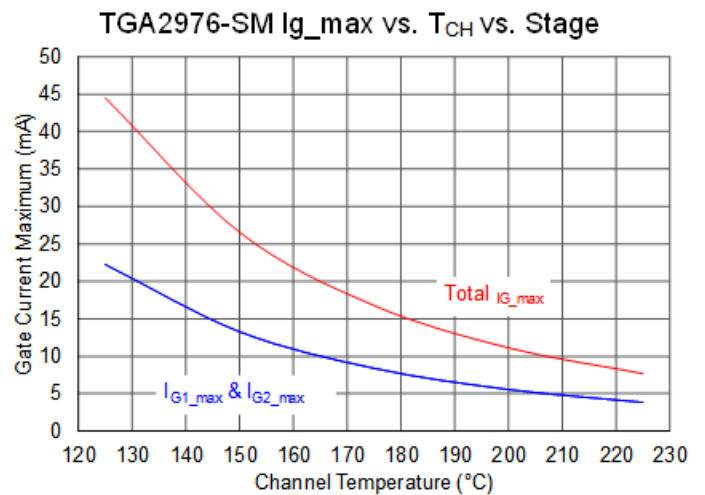
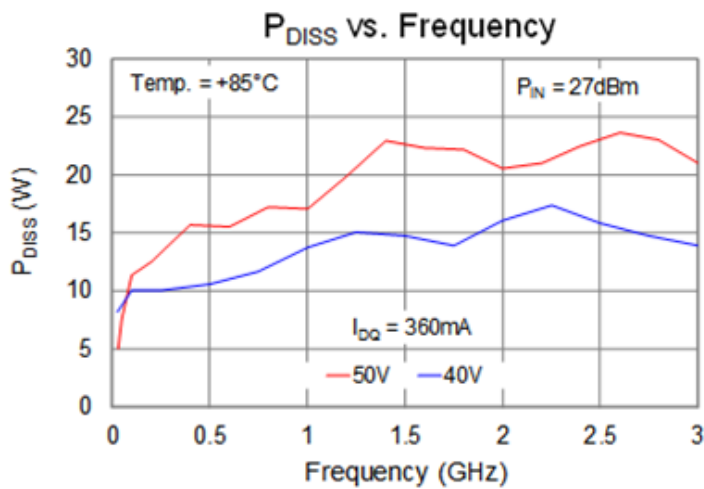

Performance Plots – Small Signal

The plots reflect performance measured with an external coaxial bias tee and DC blocks
(See application circuit on page 12)

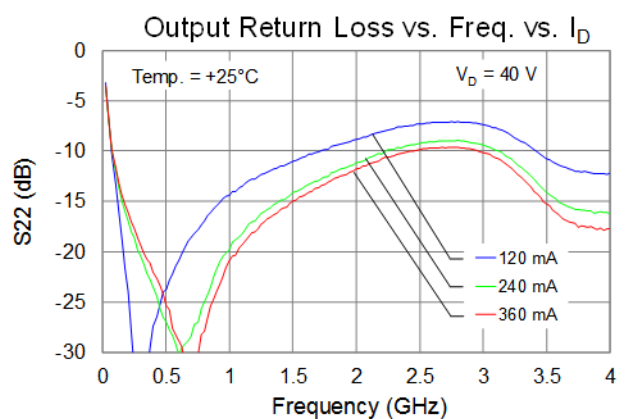
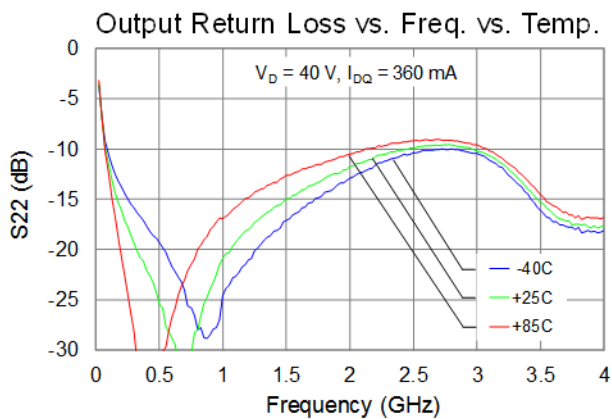
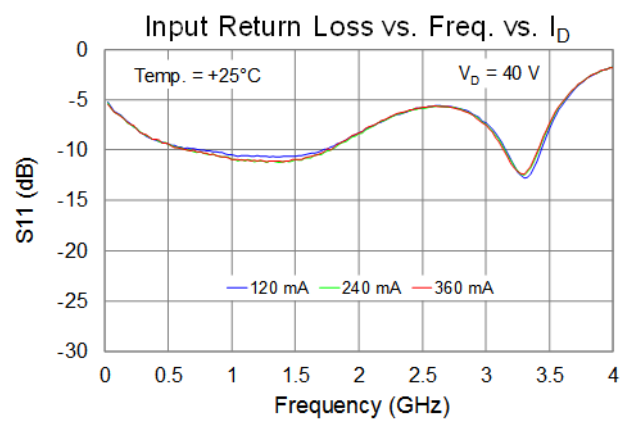
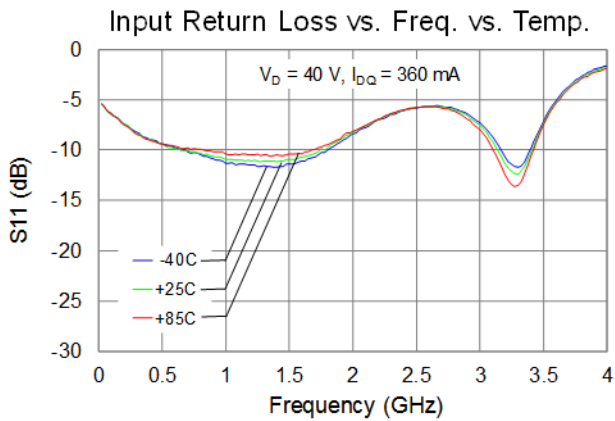
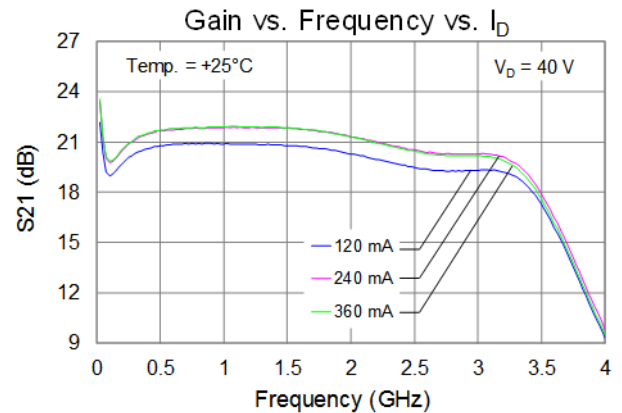
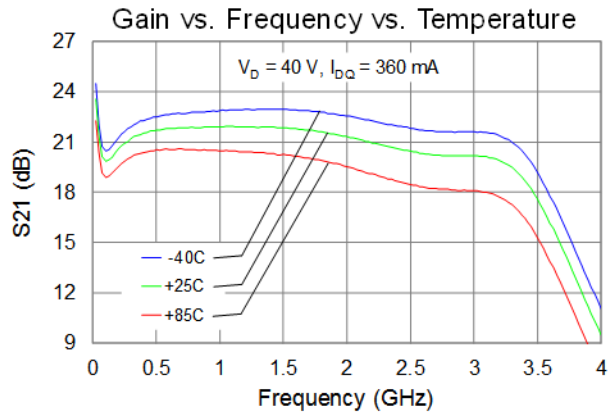

Performance Plots – Small Signal

The plots reflect performance measured with an external coaxial bias tee and DC blocks
(See application circuit on page 12)

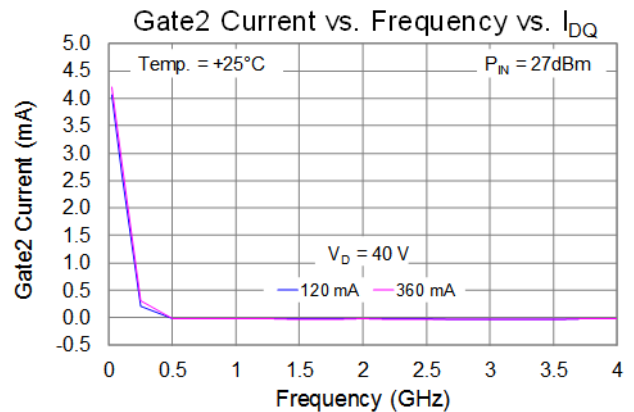
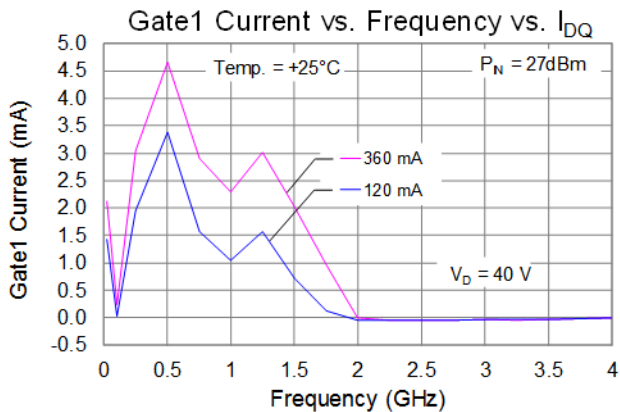
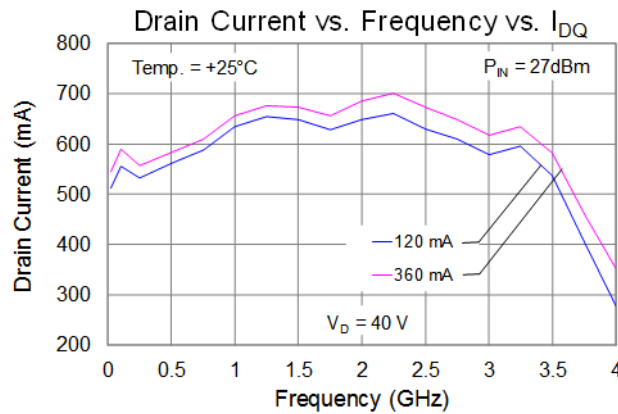
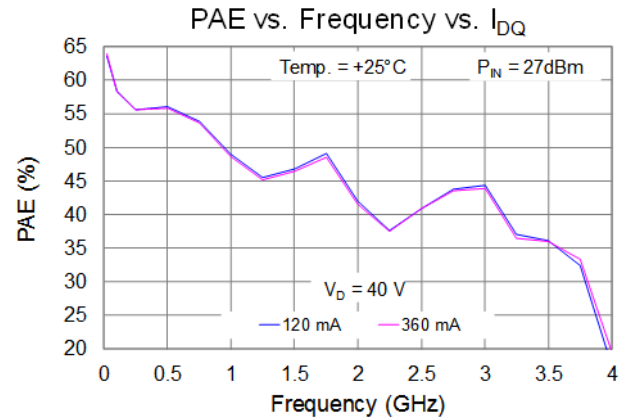
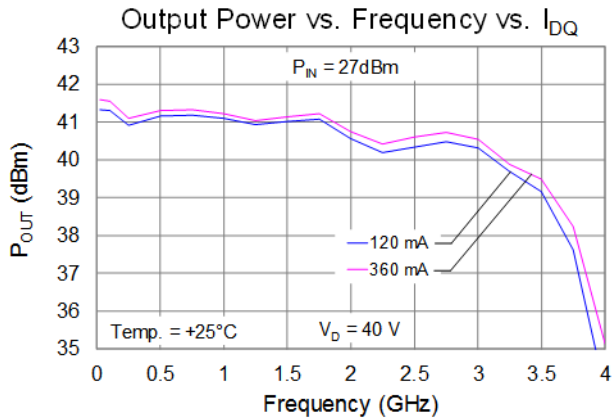

Performance Plots – Large Signal (CW)

The plots reflect performance measured with an external coaxial bias tee and DC blocks
(See application circuit on page 12)

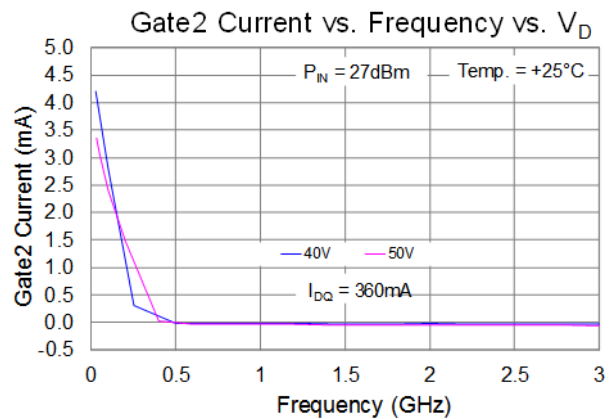
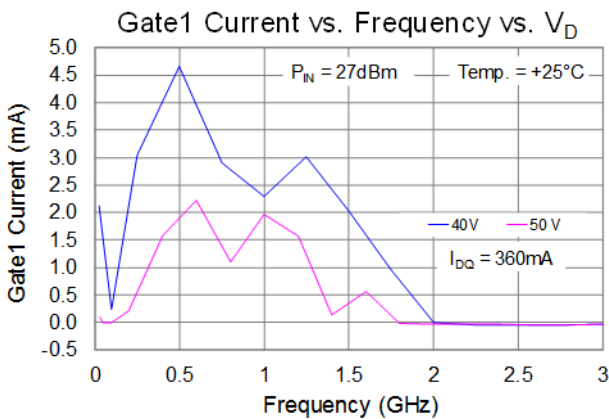
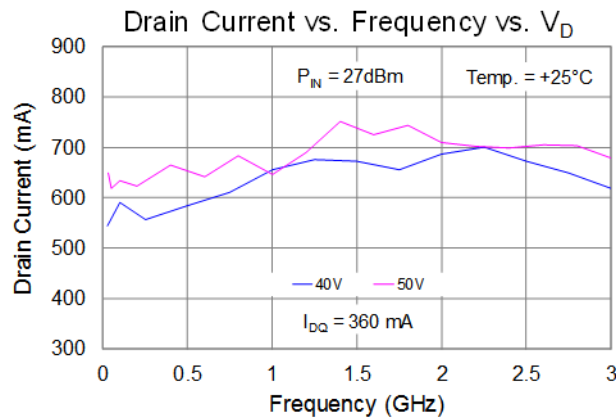
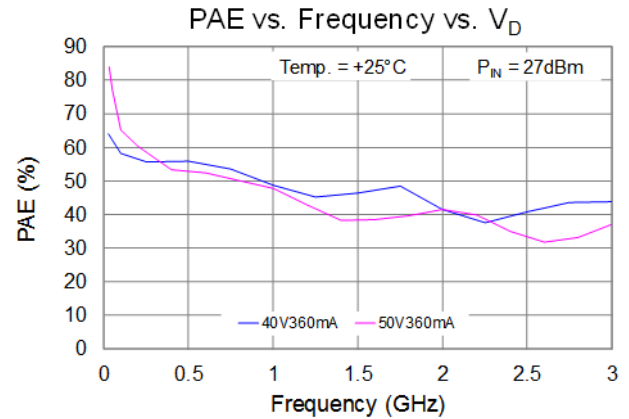
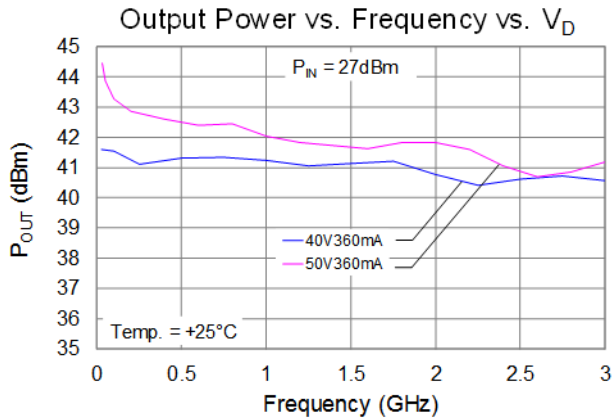

Performance Plots – Large Signal (CW)

The plots reflect performance measured with an external coaxial bias tee and DC blocks
(See application circuit on page 12)

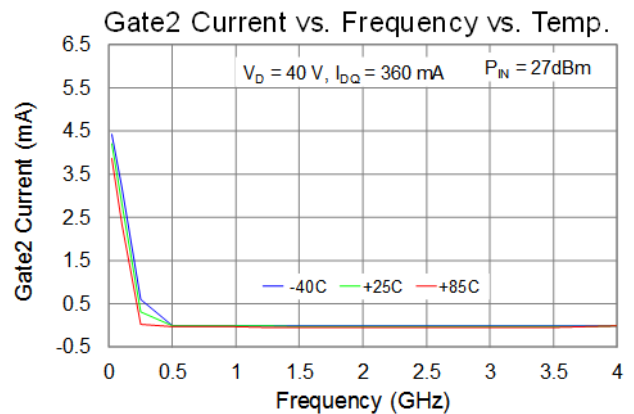
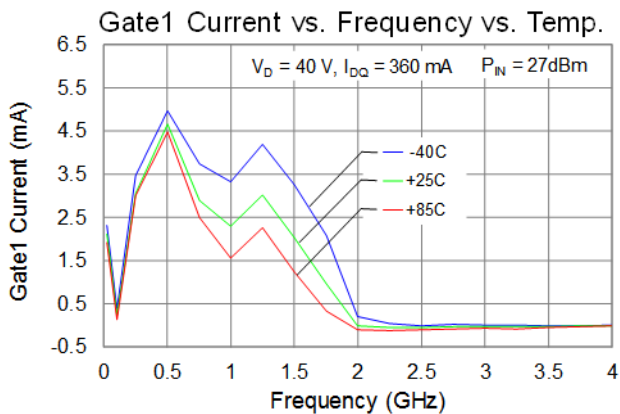
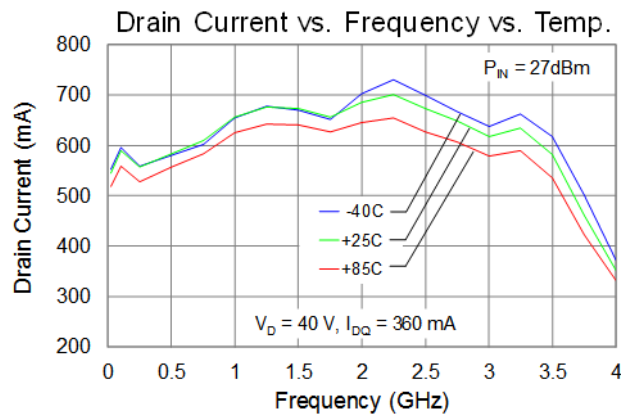
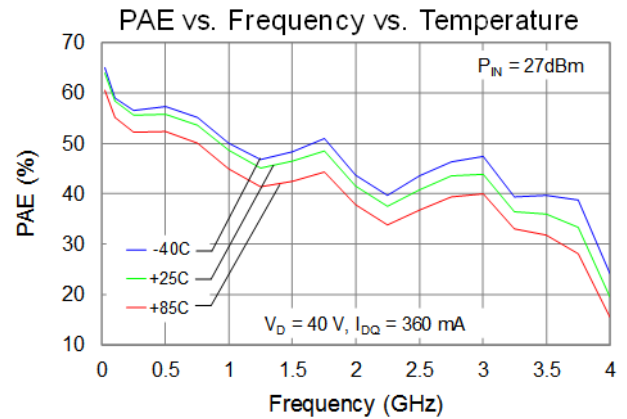
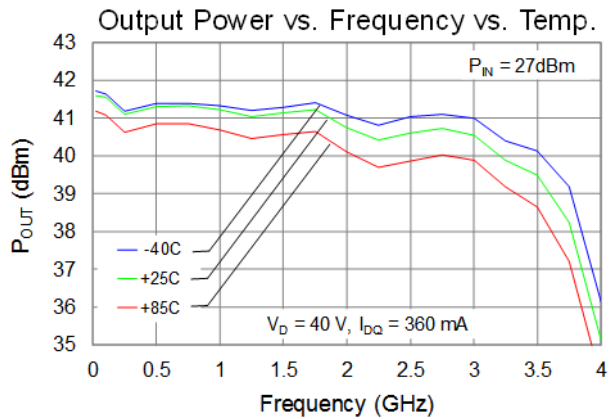

Performance Plots – Large Signal (CW)

The plots reflect performance measured with an external coaxial bias tee and DC blocks
(See application circuit on page 12)

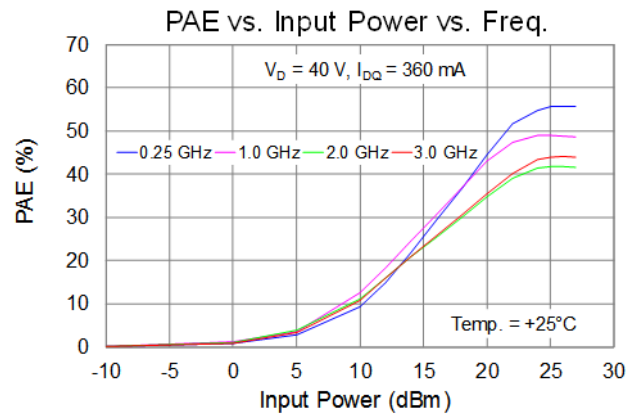
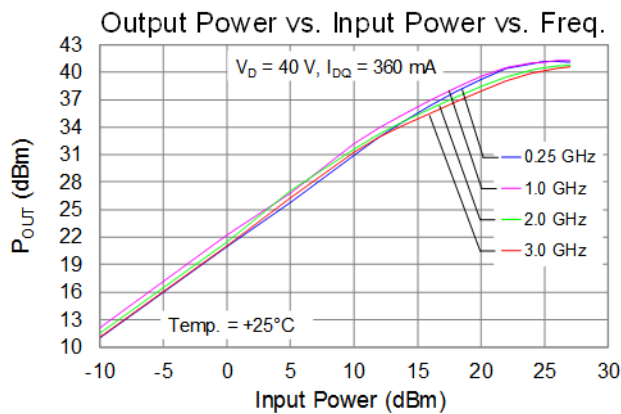
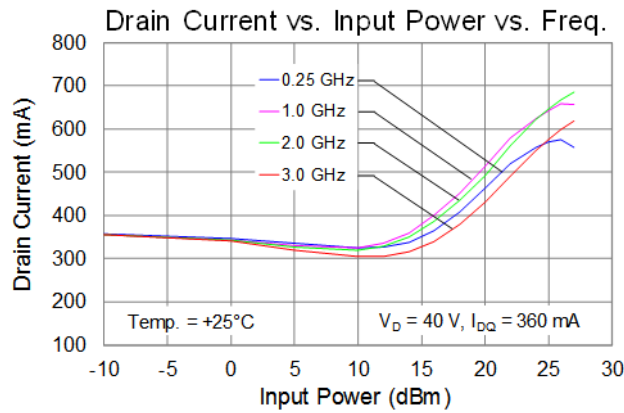
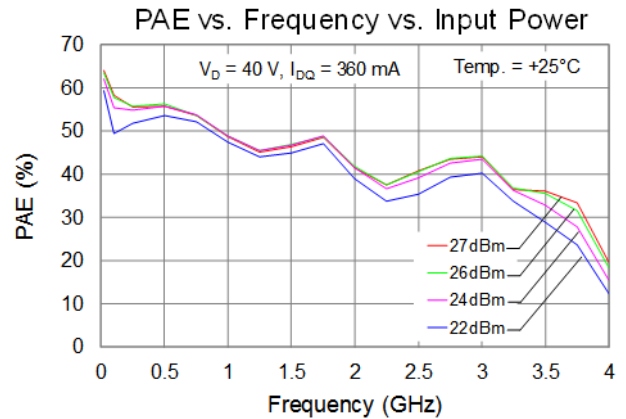
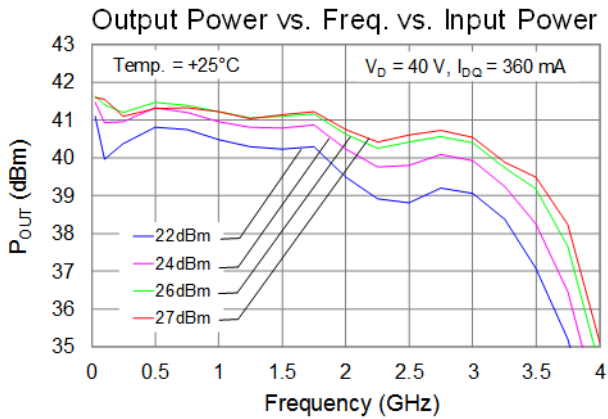

Performance Plots – Linearity

The plots reflect performance measured with an external coaxial bias tee and DC blocks
(See application circuit on page 12)

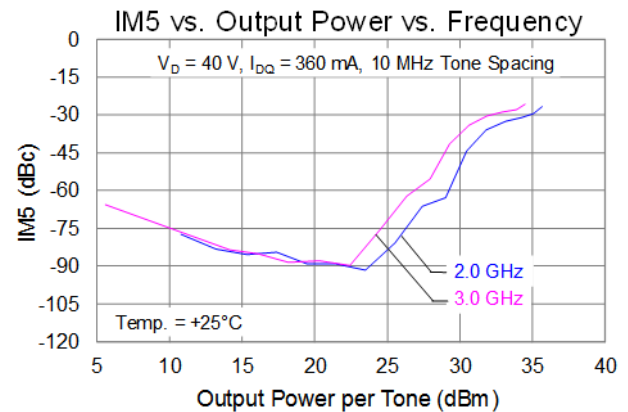
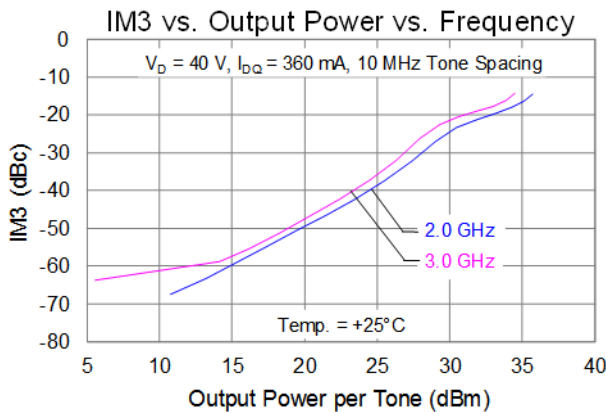
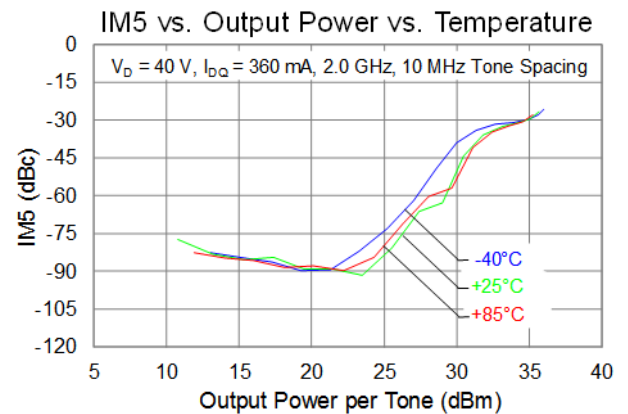
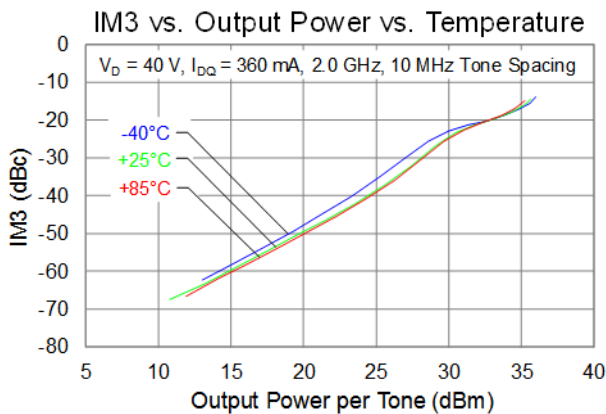
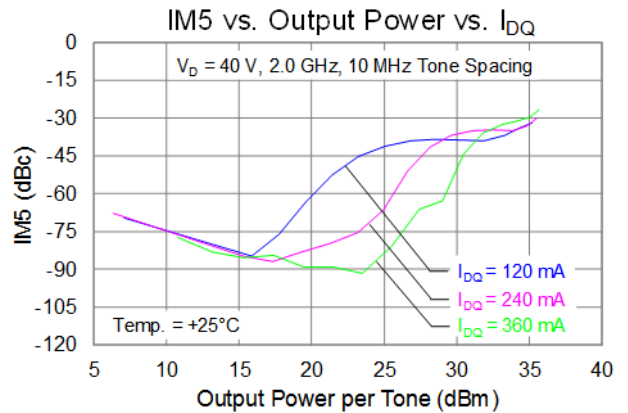
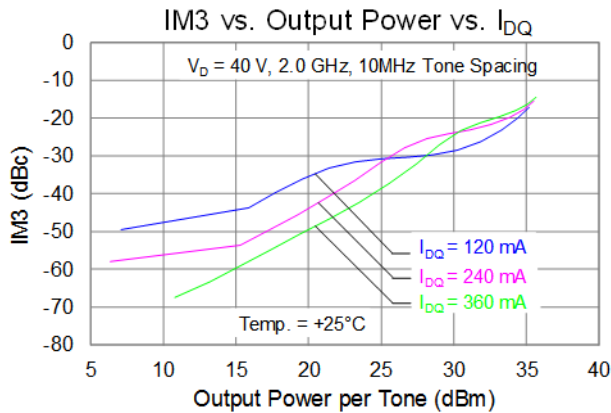

Performance Plots – Linearity

The plots reflect performance measured with an external coaxial bias tee and DC blocks
(See application circuit on page 12)

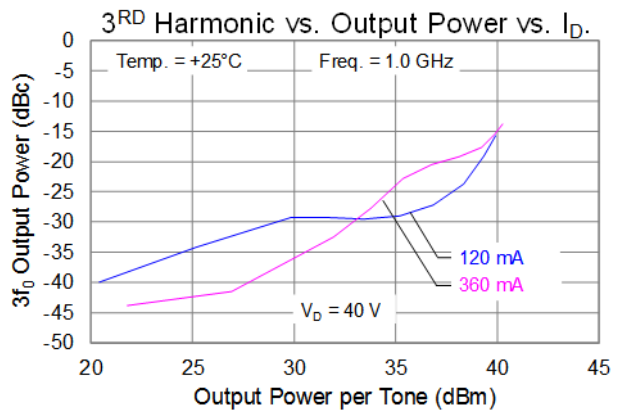
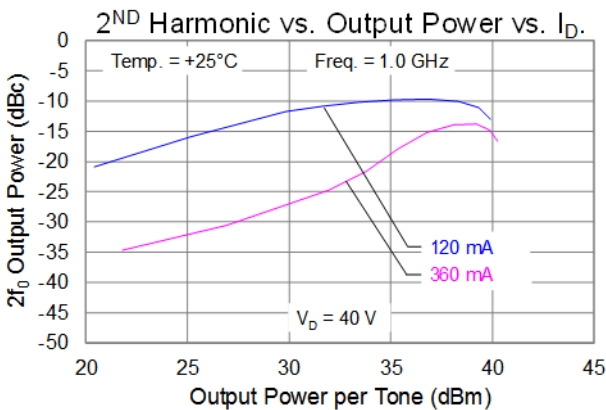
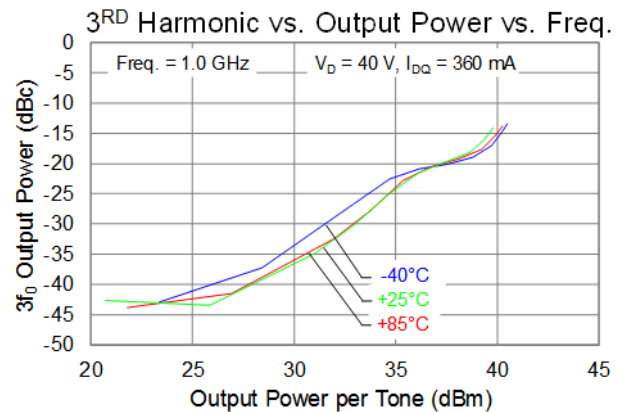
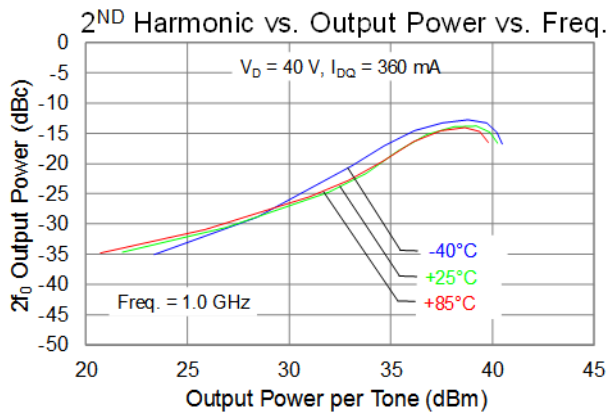
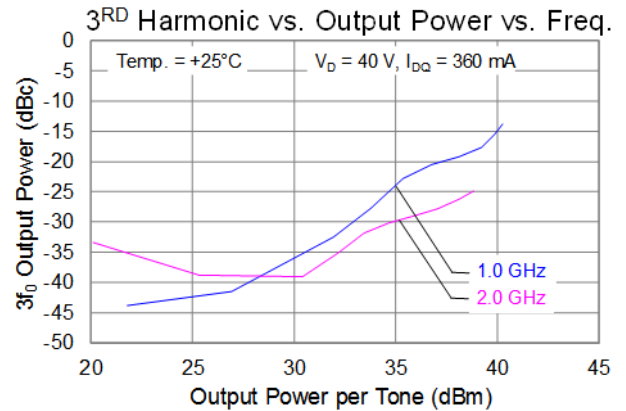
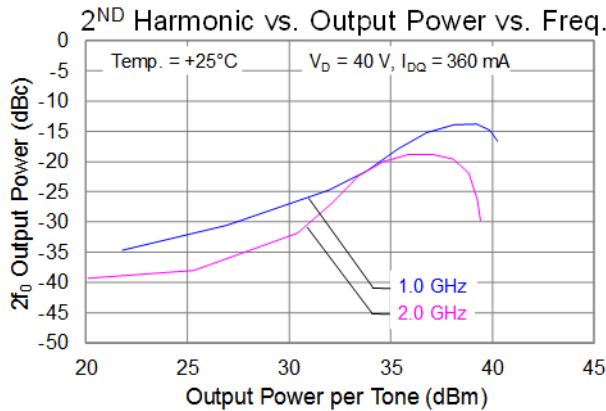

Performance Plots – Large Signal (CW), On-board vs. External Bias-T

The plots below reflect performance measured between external bias tee and on-board bias tee
 (See application circuit on page 12 and 14)

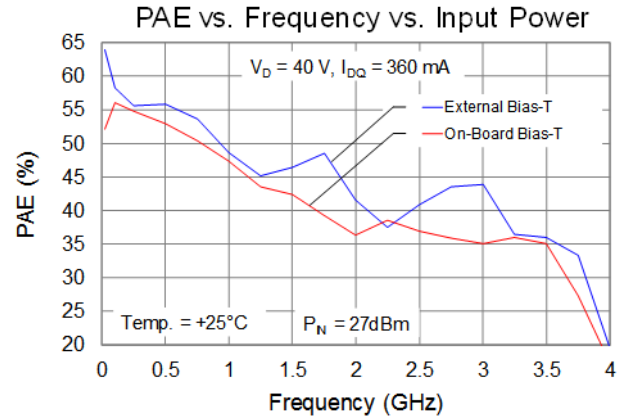
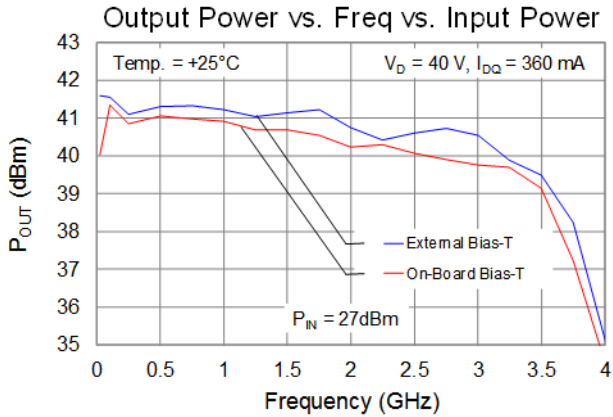

Application Circuit (Coaxial Input DC Block and Coaxial Output Bias-T)

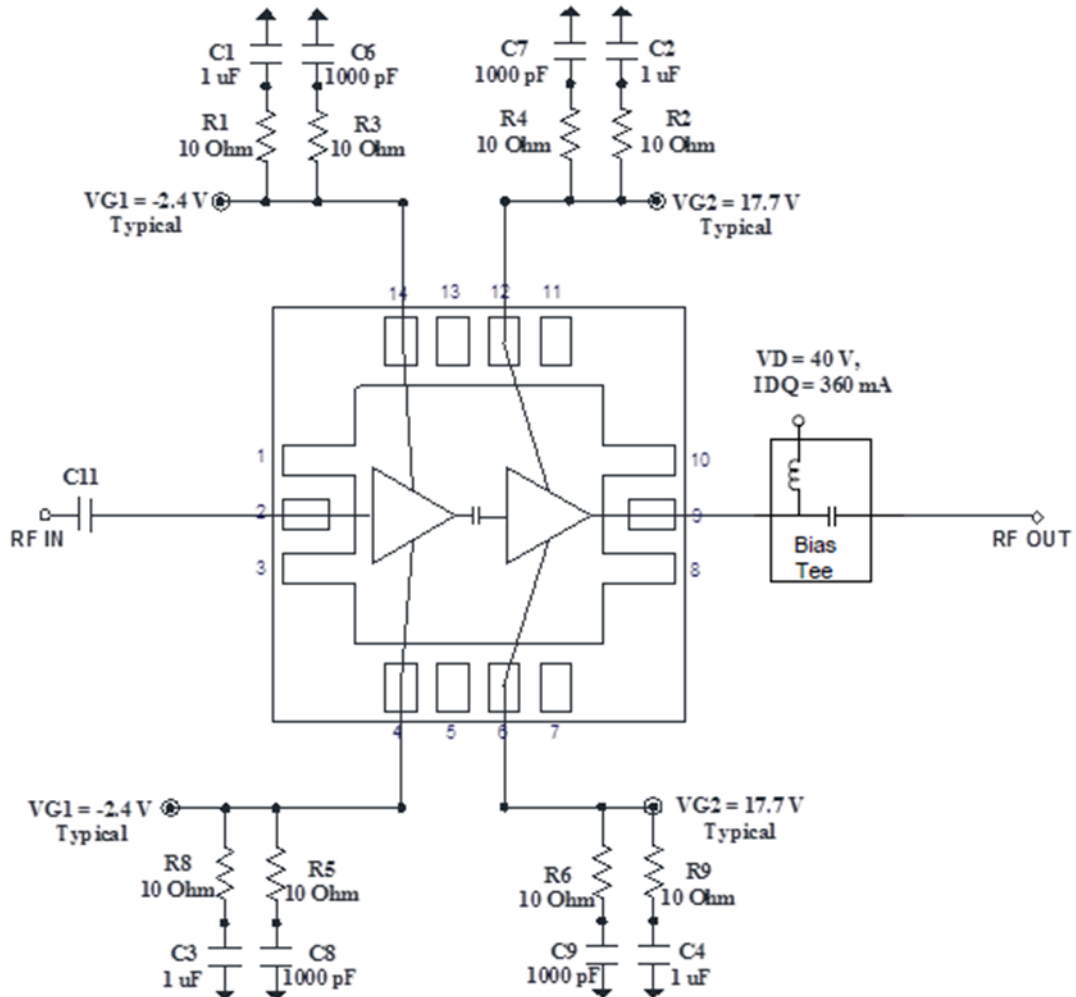

Notes:

1. V_{G1} & V_{G2} can be biased from either side (Top or Bottom.)
2. Coaxial input DC block (C11) is used for input port (RF In.)
3. External wide bandwidth Bias-Tee is used for output port (RF Out). V_D is applied through the output Bias-Tee.

Bias-Up Procedure

1. Set I_D limit to 755 mA, I_{G1} & I_{G2} limit to 5 mA
2. Set V_{G1} to -5.0 V
3. Set V_{G2} to $(V_D/2) - 2.7$ V or $(40$ V/2) - 2.7 V = 17.3 V
4. Set V_D +40 V
5. Adjust V_{G1} more positive until $I_{DQ} = 360$ mA
6. Adjust V_{G2} to $(V_D/2) + V_{G1}$; ($V_{G2} \sim +17.7$ V Typical)
7. Apply RF signal

Bias-Up Procedure

1. Turn off RF signal
2. Reduce V_{G1} to -5.0 V. Ensure $I_{DQ} \sim 0$ mA
3. Reduce V_{G2} to 0 V.
4. Set V_D to 0 V
5. Turn off V_D supply
6. Turn off V_{G2} supply
7. Turn off V_{G1} supply

EVB Assembly Drawing (Coaxial Input DC Block and Coaxial Output Bias-T)

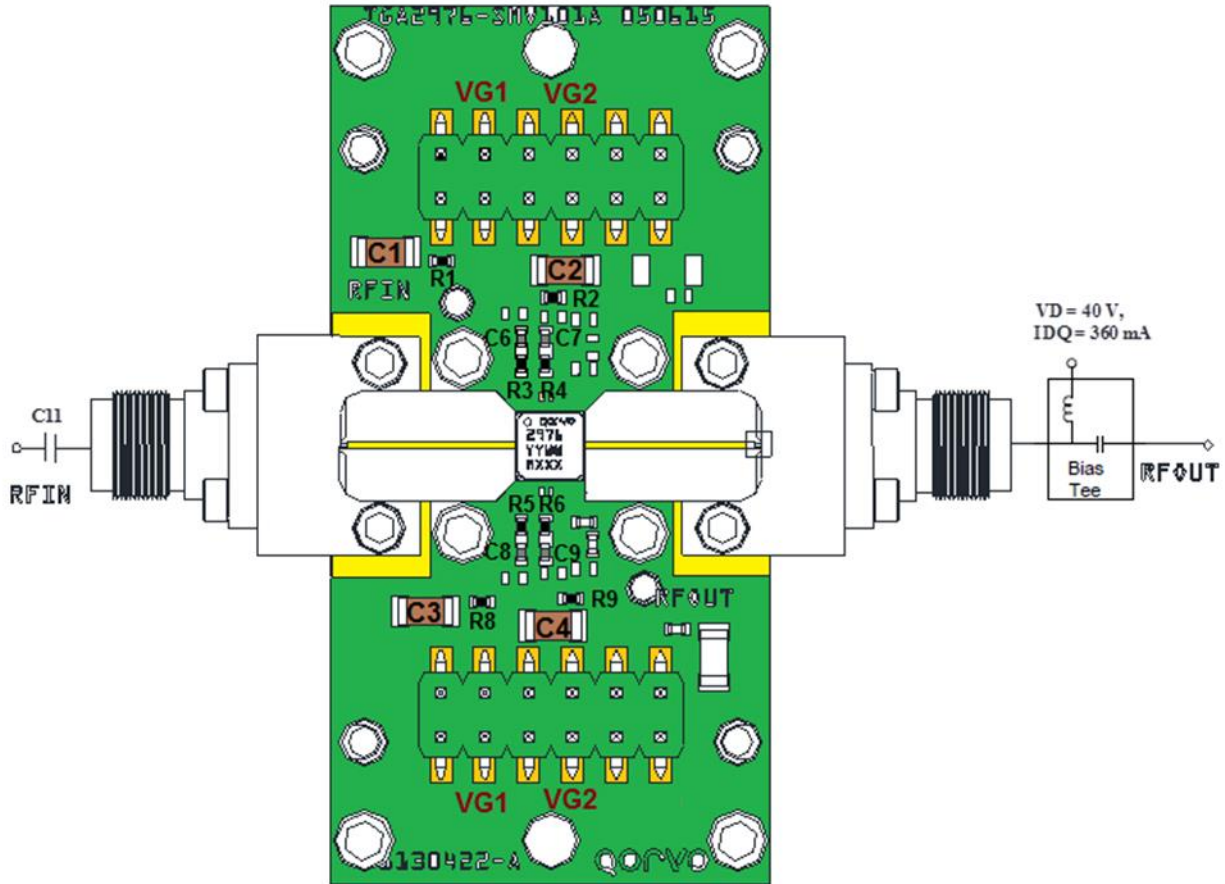

Bill of Materials

Reference Des.	Value	Description	Manuf.	Part Number
C1 – C4	1uF	Cap, 1206, 50V, 5%, X7R	Various	
C6 – C9	1000pF	Cap, 0402, 100V, 10%, X7R	Various	
C11		DC Block	Various	
R1 – R6, R8 – R9	10Ω	Res, 0402, 5%	Various	

Application Circuit (Option with Board-Level DC Blocks and Output Bias-T)

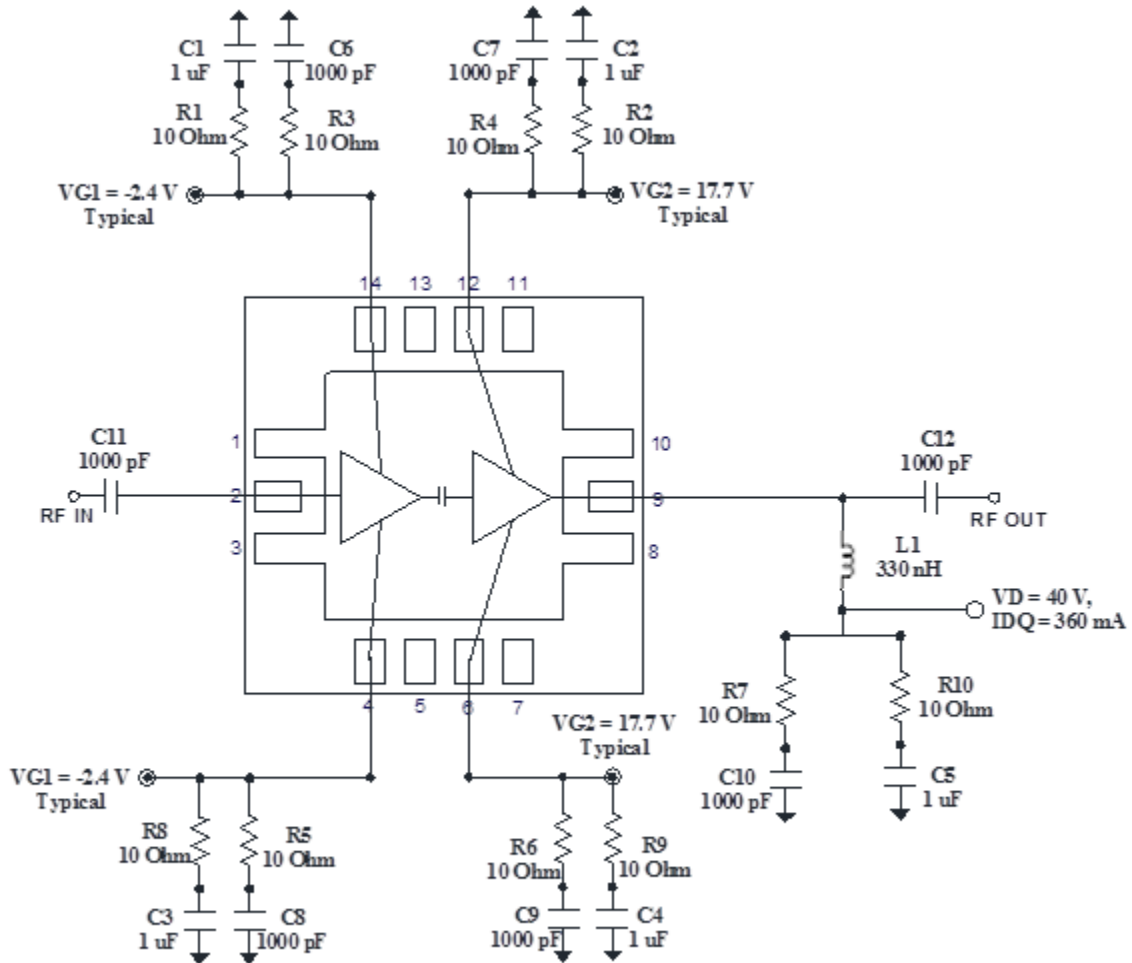

Notes:

1. Performance of the DUT with surface mount DC blocks and bias tee components may be degraded relative to the coaxial option. These components should be optimized for the desired operational bandwidth.
2. V_{G1} & V_{G2} can be biased from either side (Top or Bottom.)

EVB Assembly Drawing (On-Board DC Blocks and Output Bias-T Option)

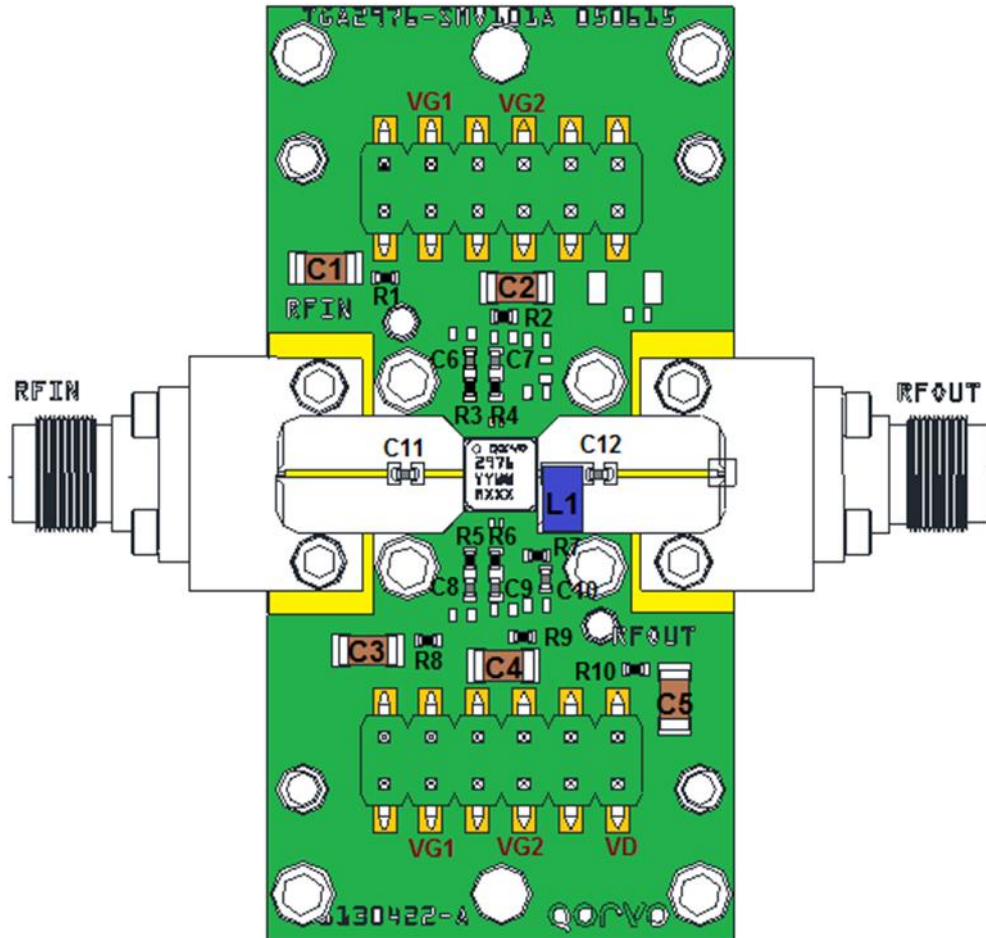

Bill of Materials for On-Board Bias-T

Reference Des.	Value	Description	Manuf.	Part Number
C1 – C5	1uF	Cap, 1206, 50V, 15%, X7R	Various	
C6 – C12	1000pF	Cap, 0402, 100V, 10%, X7R	Various	
L1	330nH	Inductor, 1206, 850 mA	Various	
R1 – R10	10Ω	Res, 0402, 5%	Various	

Mechanical Drawing and Pad Description

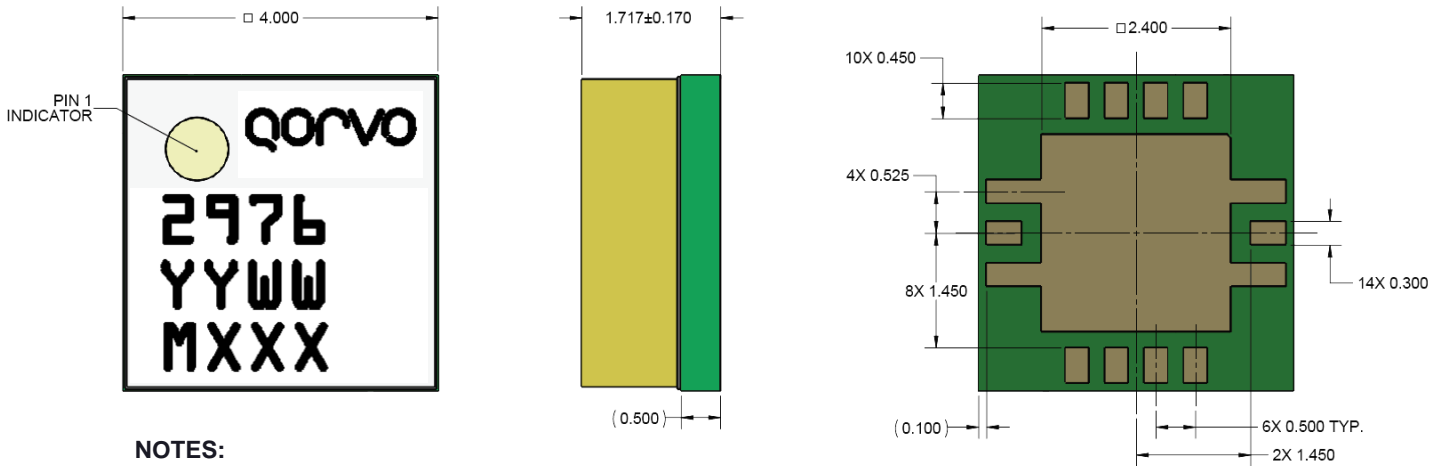

- NOTES:**
1. PACKAGE BASE: LAMINATE
 2. PACKAGE LID: FR4
 3. ALL METALIZED FEATURES ARE GOLD PLATED.
 4. THE PART IS EPOXY SEALED

Units: millimeters
Tolerances: unless specified
x.xx = ± 0.25
x.xxx = ± 0.100

Marking:
2976: Part Number
YY: Part Assembly Year
WW: Part Assembly Week
MXXX: Batch ID

Pad No.	Symbol	Description
1, 3, 8, 10	GND	Connected to ground paddle (pin 15); must be grounded on PCB.
2	RF IN	Input; matched to 50 Ω.
4, 14	GATE1	Gate voltage1; bias network is required; see recommended Application Information on page 12.
5, 7, 11, 13	N/C	No internal connection; should be connected to PCB ground.
6, 12	GATE2	Gate voltage2; bias network is required; see recommended Application Information on page 12.
9	RF OUT/ DRAIN	Output; matched to 50 Ω.
15	GND	Ground Paddle. Multiple vias should be employed to minimize inductance and thermal resistance.

Assembly Notes

Compatible with lead-free soldering processes with 260°C peak reflow temperature.

This package is air-cavity and non-hermetic, and therefore cannot be subjected to aqueous washing. The use of no-clean solder to avoid washing after soldering is highly recommended.

Contact plating: Ni-Au.

Solder rework not recommended.

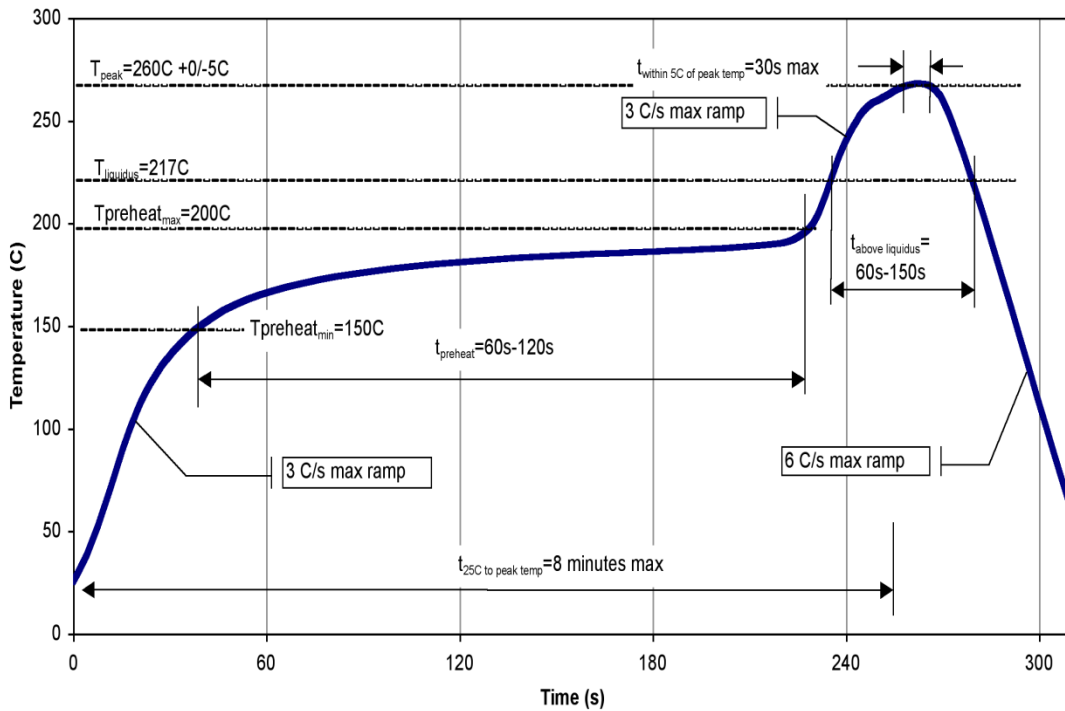

Recommended Soldering Temperature Profile

Handling Precautions

Parameter	Rating	Standard
ESD – Human Body Model (HBM)	1C	ESDA / JEDEC JS-001-2012
ESD – Charged Device Model (CDM)	C3	JEDEC JESD22-C101F
MSL – Moisture Sensitivity Level	3	IPC/JEDEC J-STD-020



Caution!
 ESD-Sensitive Device

RoHS Compliance

This part is compliant with 2011/65/EU RoHS directive (Restrictions on the Use of Certain Hazardous Substances in Electrical and Electronic Equipment) as amended by Directive 2015/863/EU.

This product also has the following attributes:

- Lead Free
- Antimony Free
- TBBP-A (C₁₅H₁₂Br₄O₂) Free

Contact Information

For the latest specifications, additional product information, worldwide sales and distribution locations:

Web: www.qorvo.com

Tel: 1-844-890-8163

Email: customer.support@qorvo.com

Important Notice

The information contained herein is believed to be reliable; however, Qorvo makes no warranties regarding the information contained herein and assumes no responsibility or liability whatsoever for the use of the information contained herein. All information contained herein is subject to change without notice. Customers should obtain and verify the latest relevant information before placing orders for Qorvo products. The information contained herein or any use of such information does not grant, explicitly or implicitly, to any party any patent rights, licenses, or any other intellectual property rights, whether with regard to such information itself or anything described by such information. **THIS INFORMATION DOES NOT CONSTITUTE A WARRANTY WITH RESPECT TO THE PRODUCTS DESCRIBED HEREIN, AND QORVO HEREBY DISCLAIMS ANY AND ALL WARRANTIES WITH RESPECT TO SUCH PRODUCTS WHETHER EXPRESS OR IMPLIED BY LAW, COURSE OF DEALING, COURSE OF PERFORMANCE, USAGE OF TRADE OR OTHERWISE, INCLUDING THE IMPLIED WARRANTIES OF MERCHANTABILITY AND FITNESS FOR A PARTICULAR PURPOSE.**

Without limiting the generality of the foregoing, Qorvo products are not warranted or authorized for use as critical components in medical, life-saving, or life-sustaining applications, or other applications where a failure would reasonably be expected to cause severe personal injury or death.

© 2020 Qorvo US, Inc. All rights reserved. This document is subject to copyright laws in various jurisdictions worldwide and may not be reproduced or distributed, in whole or in part, without the express written consent of Qorvo US, Inc.

X-ON Electronics

Largest Supplier of Electrical and Electronic Components

Click to view similar products for [RF Amplifier](#) category:

Click to view products by [Qorvo](#) manufacturer:

Other Similar products are found below :

[A82-1](#) [BGA622H6820XTSA1](#) [BGA 728L7 E6327](#) [BGB719N7ESDE6327XTMA1](#) [HMC397-SX](#) [HMC405](#) [HMC561-SX](#) [HMC8120-SX](#)
[HMC8121-SX](#) [HMC-ALH382-SX](#) [HMC-ALH476-SX](#) [SE2433T-R](#) [SMA3101-TL-E](#) [SMA39](#) [A66-1](#) [A66-3](#) [A67-1](#) [LX5535LQ](#) [LX5540LL](#)
[MAAM02350](#) [HMC3653LP3BETR](#) [HMC549MS8GETR](#) [HMC-ALH435-SX](#) [SMA101](#) [SMA32](#) [SMA411](#) [SMA531](#) [SST12LP17E-XX8E](#)
[SST12LP19E-QX6E](#) [WPM0510A](#) [HMC5929LS6TR](#) [HMC5879LS7TR](#) [HMC1126](#) [HMC1087F10](#) [HMC1086](#) [HMC1016](#) [SMA1212](#)
[MAX2689EWS+T](#) [MAAMSS0041TR](#) [MAAM37000-A1G](#) [LTC6430AIUF-15#PBF](#) [CHA5115-QDG](#) [SMA70-2](#) [SMA4011](#) [A231](#) [HMC-](#)
[AUH232](#) [LX5511LQ](#) [LX5511LQ-TR](#) [HMC7441-SX](#) [HMC-ALH310](#)