

17 - 43 GHz MPA / Multiplier

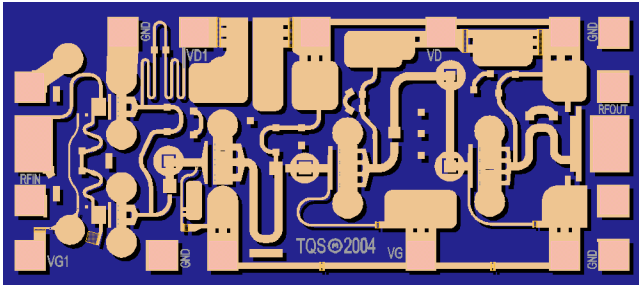

Key Features

- Frequency: 17 - 43 GHz
- 25 dB Nominal Gain @ Mid-band
- 22 dBm Nominal Output P1dB
- 2x and 3x Multiplier Function
- 0.15 um 3MI pHEMT Technology
- Chip Dimensions 1.72 x 0.76 x 0.10 mm (0.068 x 0.030 x 0.004 in)

Primary Applications

- Point-to-point radio
- EW
- Instrumentation
- Frequency Multiplier

Product Description

The TriQuint TG4040 is a Medium Power Amplifier and Multiplier for a wide band of 17 – 43GHz applications. The part is designed using TriQuint’s 0.15um power pHEMT production process.

The TGA4040 provides a nominal 25 dB small signal gain with 22 dBm output power @ 1 dB gain compression. For 2x and 3x Multiplier Function, TGA4040 provides 15 dBm typical of Output Power @ 9 dBm Pin.

The part is ideally suited for applications such as Point-to-Point Radio, EW, Instrumentation and frequency multipliers.

The TGA4040 is 100% DC and RF tested on-wafer to ensure performance compliance.

The TGA4040 has a protective surface passivation layer providing environmental robustness.

Lead-Free & RoHS compliant.

Amplifier Performance

Bias Conditions: $V_d = 5\text{ V}$, $I_{dq} = 139\text{ mA}$

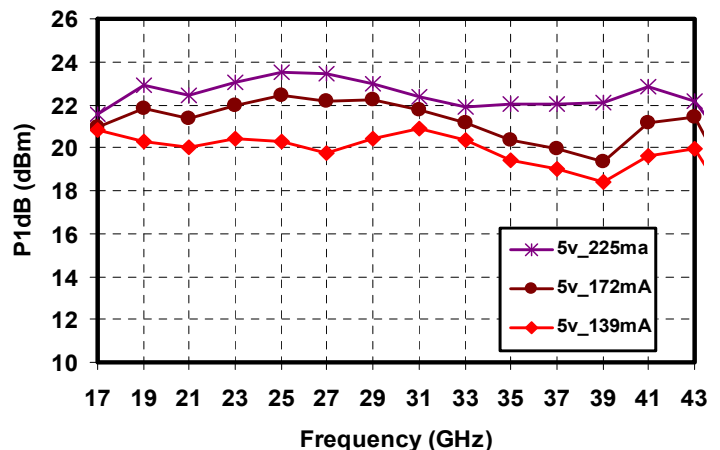
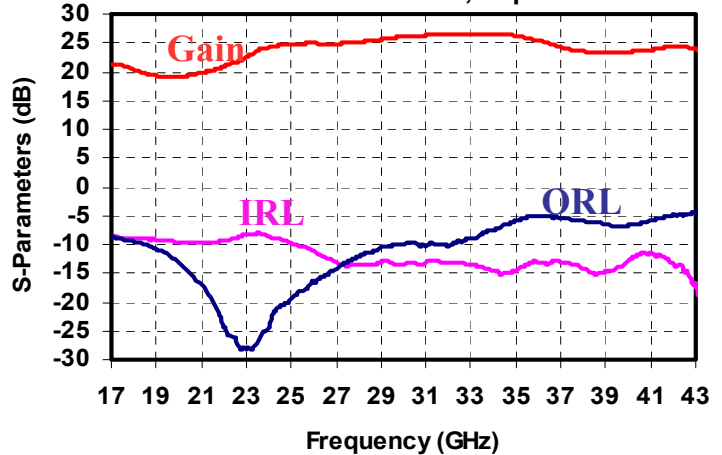

Datasheet subject to change without notice

**TABLE I
 MAXIMUM RATINGS 1/**

SYMBOL	PARAMETER	VALUE	NOTES
V _d	Drain Voltage	6 V	<u>2/</u>
V _g	Gate Voltage Range	-2 TO 0 V	
I _d	Drain Current	TBD	<u>2/ 3/</u>
I _g	Gate Current	7 mA	<u>3/</u>
P _{IN}	Input Continuous Wave Power	20 dBm	
P _D	Power Dissipation	1.95 W	<u>2/ 4/</u>
T _{CH}	Operating Channel Temperature	200 °C	<u>5/</u>
	Mounting Temperature (30 Seconds)	320 °C	
T _{STG}	Storage Temperature	-65 to 150 °C	

- 1/ These ratings represent the maximum operable values for this device.
- 2/ Combinations of supply voltage, supply current, input power, and output power shall not exceed P_D.
- 3/ Total current for the entire MMIC.
- 4/ When operated at this power dissipation with a base plate temperature of 70 °C, the median life is 7.3E3 hours.
- 5/ Junction operating temperature will directly affect the device median time to failure (T_m). For maximum life, it is recommended that junction temperatures be maintained at the lowest possible levels.

TABLE II
ELECTRICAL CHARACTERISTICS
 (Ta = 25 °C Nominal)

PARAMETER	Amplifier	2x Multiplier	3x Multiplier	UNITS
Frequency Range	17 - 43	9 - 22	6 - 12	GHz
Drain Voltage, Vd1*	-	-	1	V
Drain Voltage, Vd*	5	5	5	V
Total Drain Current*	139	120	160	mA
Gate Voltage, Vg1*	-0.65	-1.1	-0.6	V
Gate Voltage, Vg*		-0.65		V
Small Signal Gain, S21	25	-	-	dB
Input Return Loss, S11	12	-	-	dB
Output Return Loss, S22	8	-	-	dB
Output Power @ 1dB Gain compression, P1dB				
5V @ 139mA	20	-	-	dBm
5V @ 225mA	22			
Output TOI	28	-	-	dBm
Output Power @ Pin = 9dBm	-	15	15	dBm
Gain Temperature Coefficient	-0.04	-	-	dB/°C

* See bias plan on page 8 for amplifier and 2x multiplier, page 9 for 3x multiplier

**TABLE III
THERMAL INFORMATION**

PARAMETER	TEST CONDITIONS	T _{CH} (°C)	θ _{JC} (°C/W)	T _m (HRS)
θ _{JC} Thermal Resistance (channel to Case)	V _d = 5 V I _d = 139 mA P _{diss} = 0.69 W	116	66.7	6.3E+7

Note: Assumes eutectic attach using 1.5 mil 80/20 AuSn mounted to a 20 mil CuMo Carrier at 70 °C baseplate temperature. Worst case condition with no RF applied, 100% of DC power is dissipated.

Median Lifetime (T_m) vs. Channel Temperature

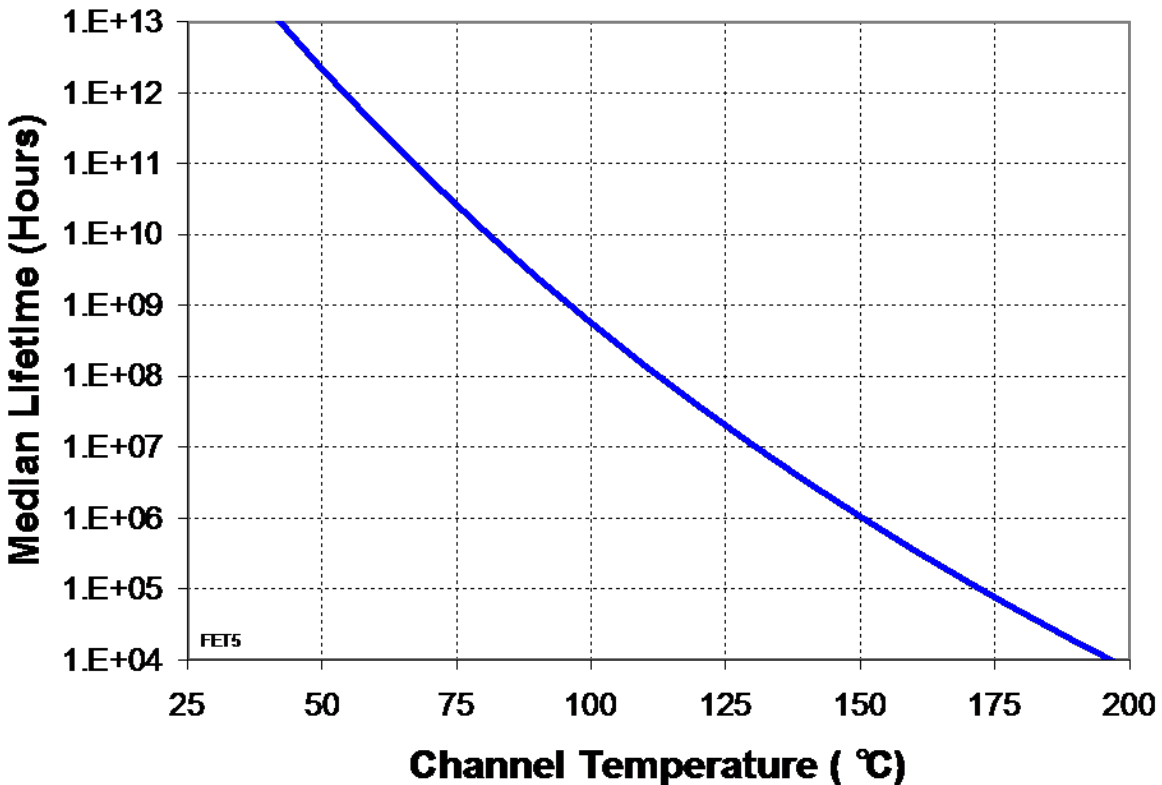

Measured Amplifier Data
Bias Conditions: $V_d = 5\text{ V}$, $I_{dq} = 139\text{ mA}$

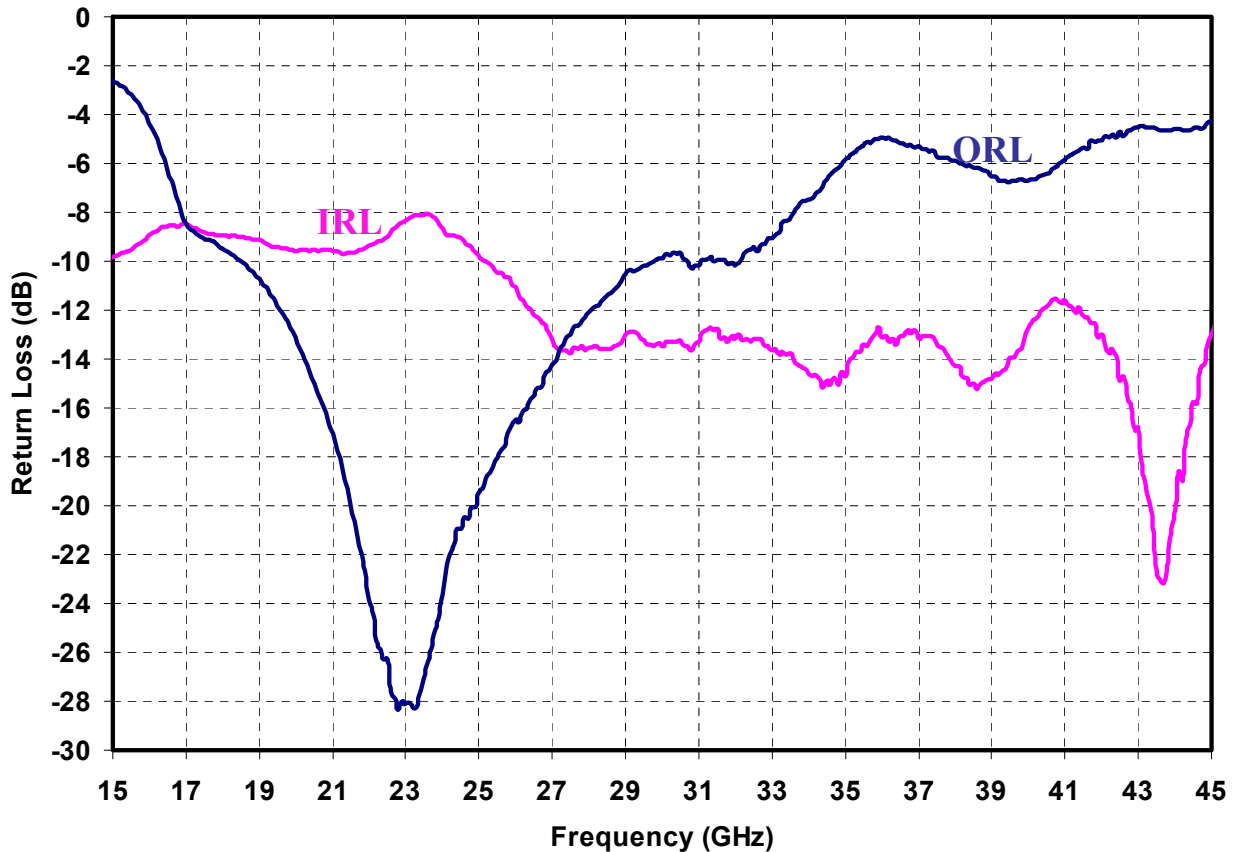
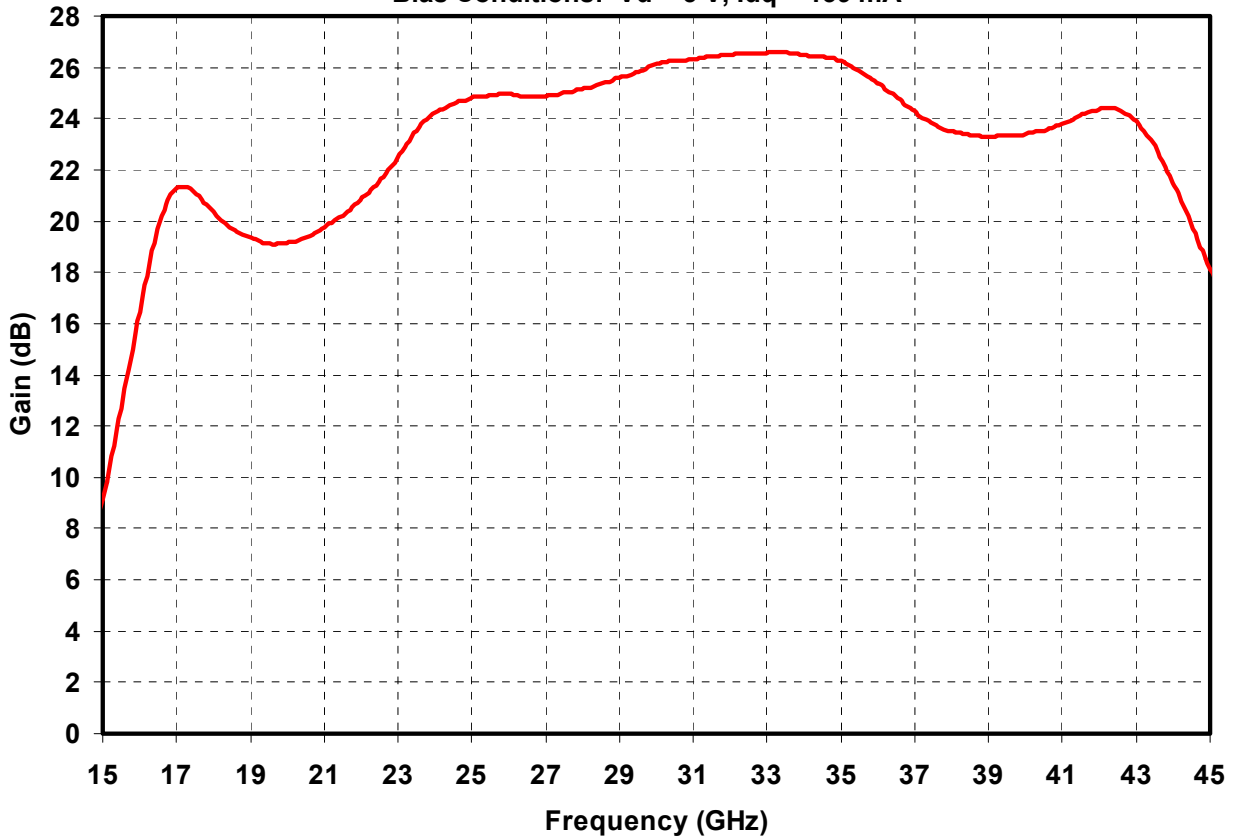

Measured Amplifier Data

Bias Conditions: $V_d = 5\text{ V}$, I_{dq} Vary

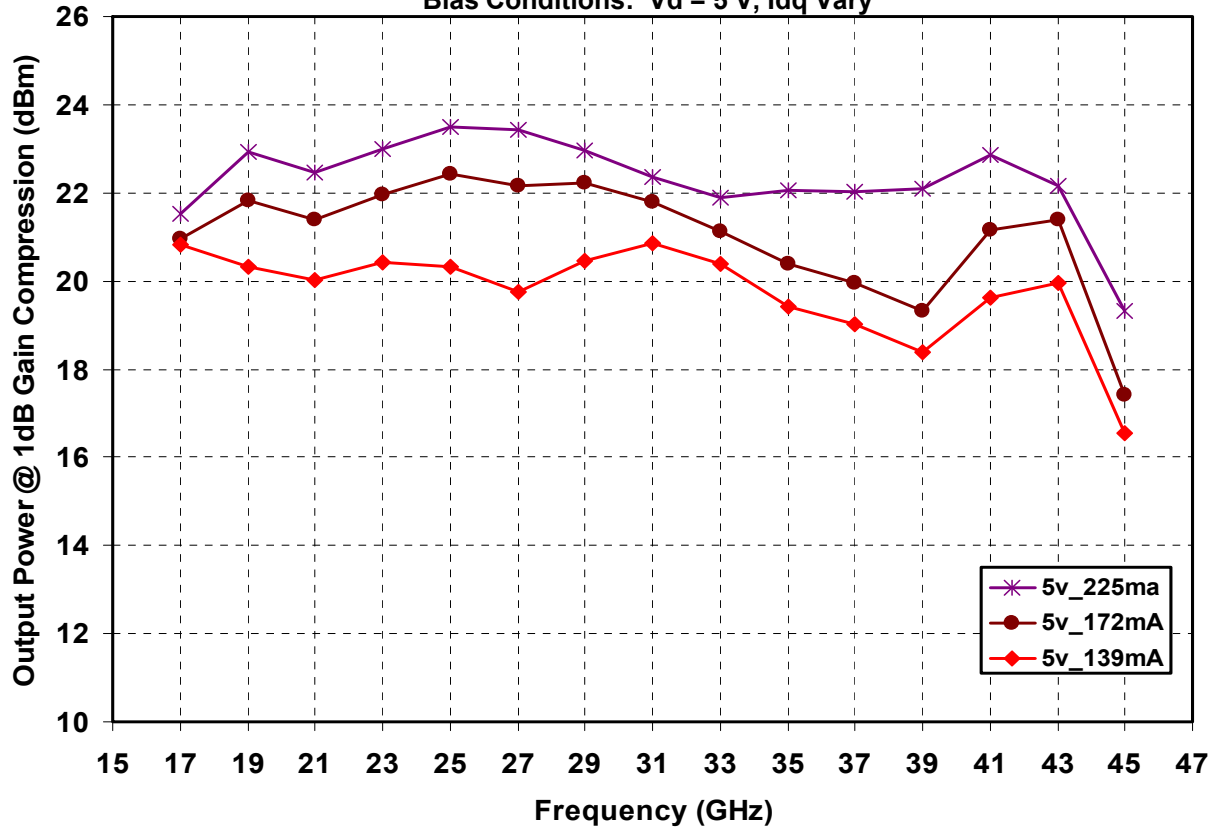

Measured 2X Multiplier Data

Bias Conditions: $V_d = 5\text{ V}$, $I_{dq} = 120\text{ mA}$, $V_{g1} = -1.1\text{ V}$, $P_{in} = 9\text{ dBm}$

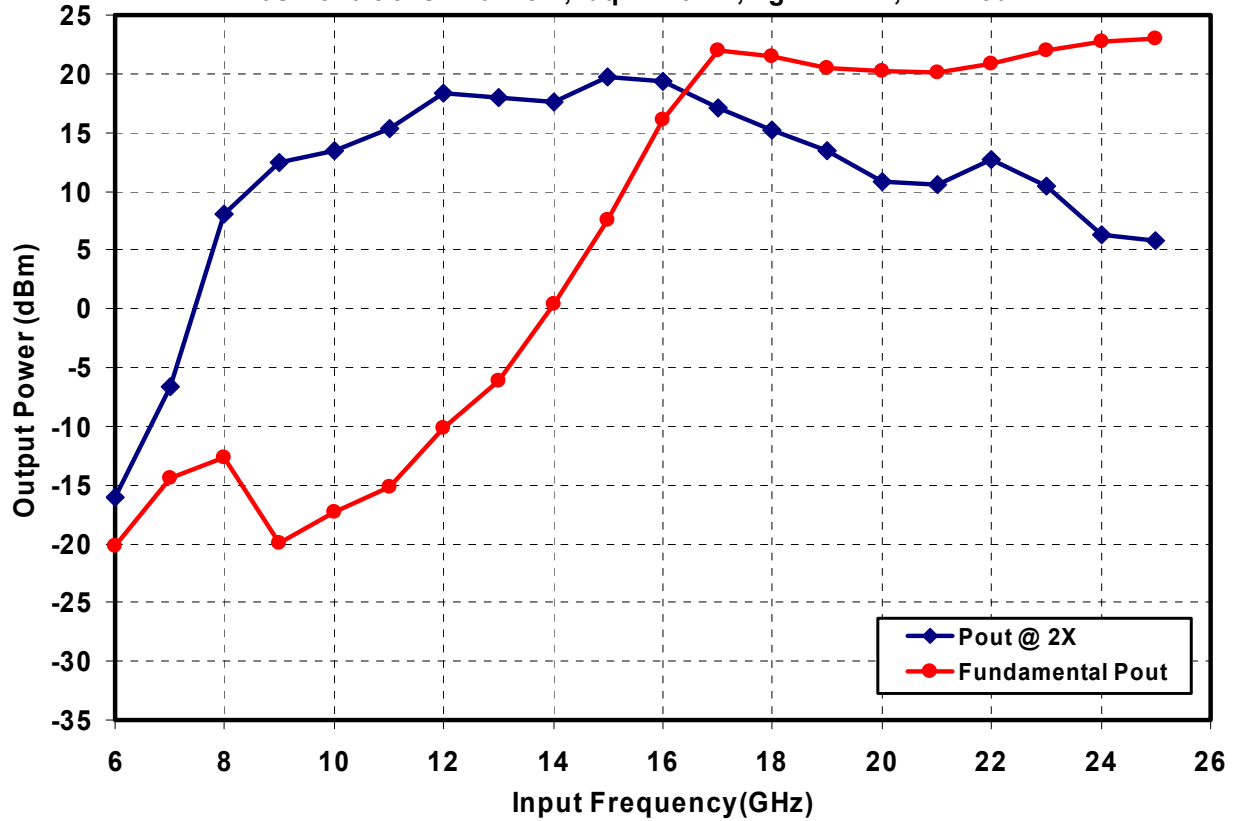

Measured 3X Multiplier Data

Bias Conditions: $V_d = 5\text{ V}$, $V_{d1} = 1\text{ V}$, $I_{dq} = 160\text{ mA}$, $P_{in} = 8\text{ dBm}$

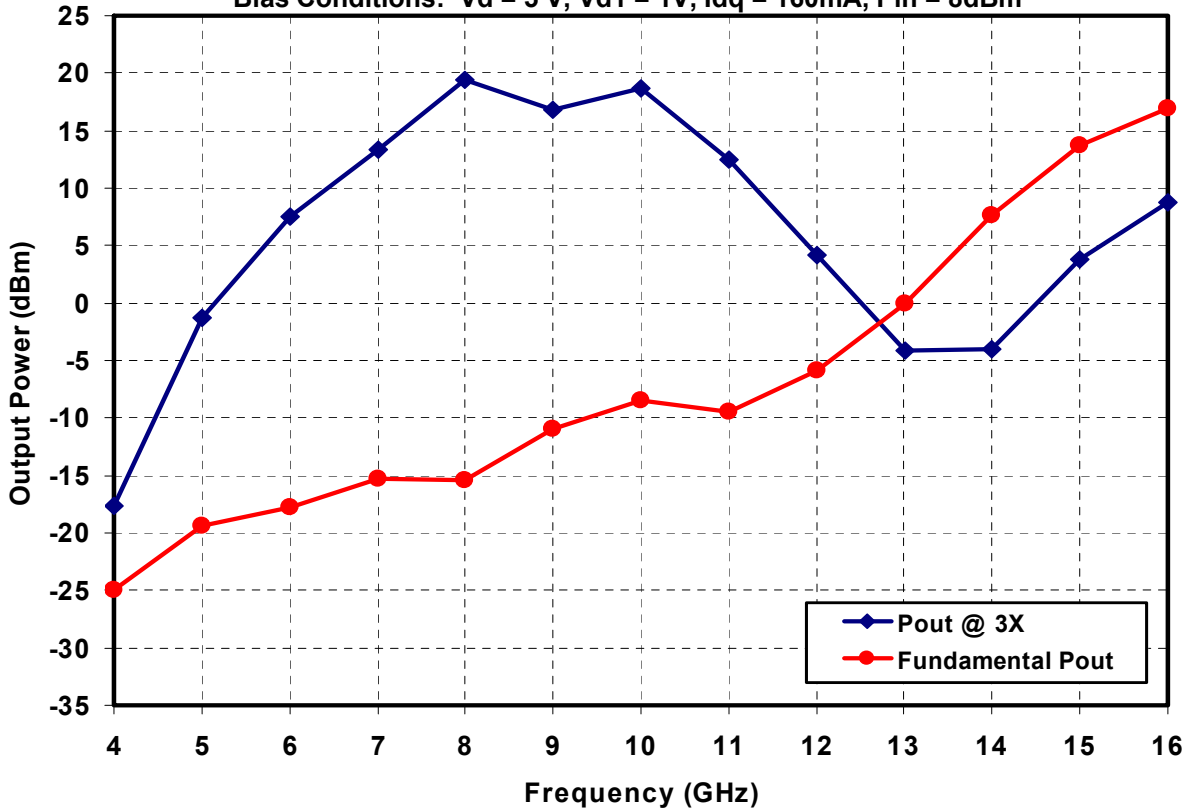

Mechanical Drawing

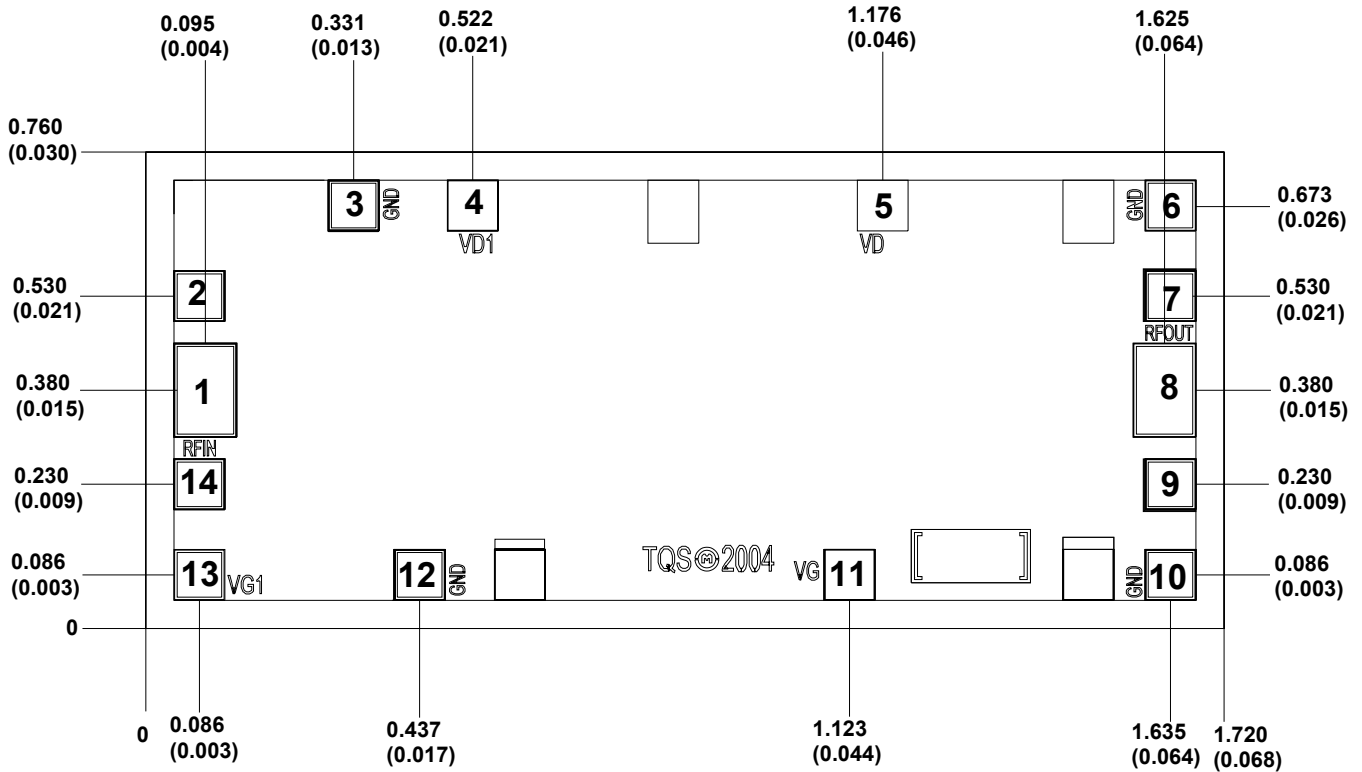

Units: millimeters (inches)
 Thickness: 0.100 (0.004)
 Chip edge to bond pad dimensions are shown to center of bond pad
 Chip size tolerance: +/- 0.051 (0.002)
 GND is back side of MMIC

Bond pad #1:	(RF In)	0.100 x 0.150 (0.004 x 0.006)
Bond pad #2, #3, #6, #7, #9, #10, #12, #14:	(GND)	0.081 x 0.081 (0.003 x 0.003)
Bond pad #4:	(Vd1)	0.081 x 0.081 (0.003 x 0.003)
Bond pad #5:	(Vd)	0.081 x 0.081 (0.003 x 0.003)
Bond pad #8:	(RF Out)	0.100 x 0.150 (0.004 x 0.006)
Bond pad #11:	(Vg)	0.081 x 0.081 (0.003 x 0.003)
Bond pad #13:	(Vg1)	0.081 x 0.081 (0.003 x 0.003)

GaAs MMIC devices are susceptible to damage from Electrostatic Discharge. Proper precautions should be observed during handling, assembly and test.

**Recommended Chip Assembly Diagram
Amplifier & 2x Multiplier**

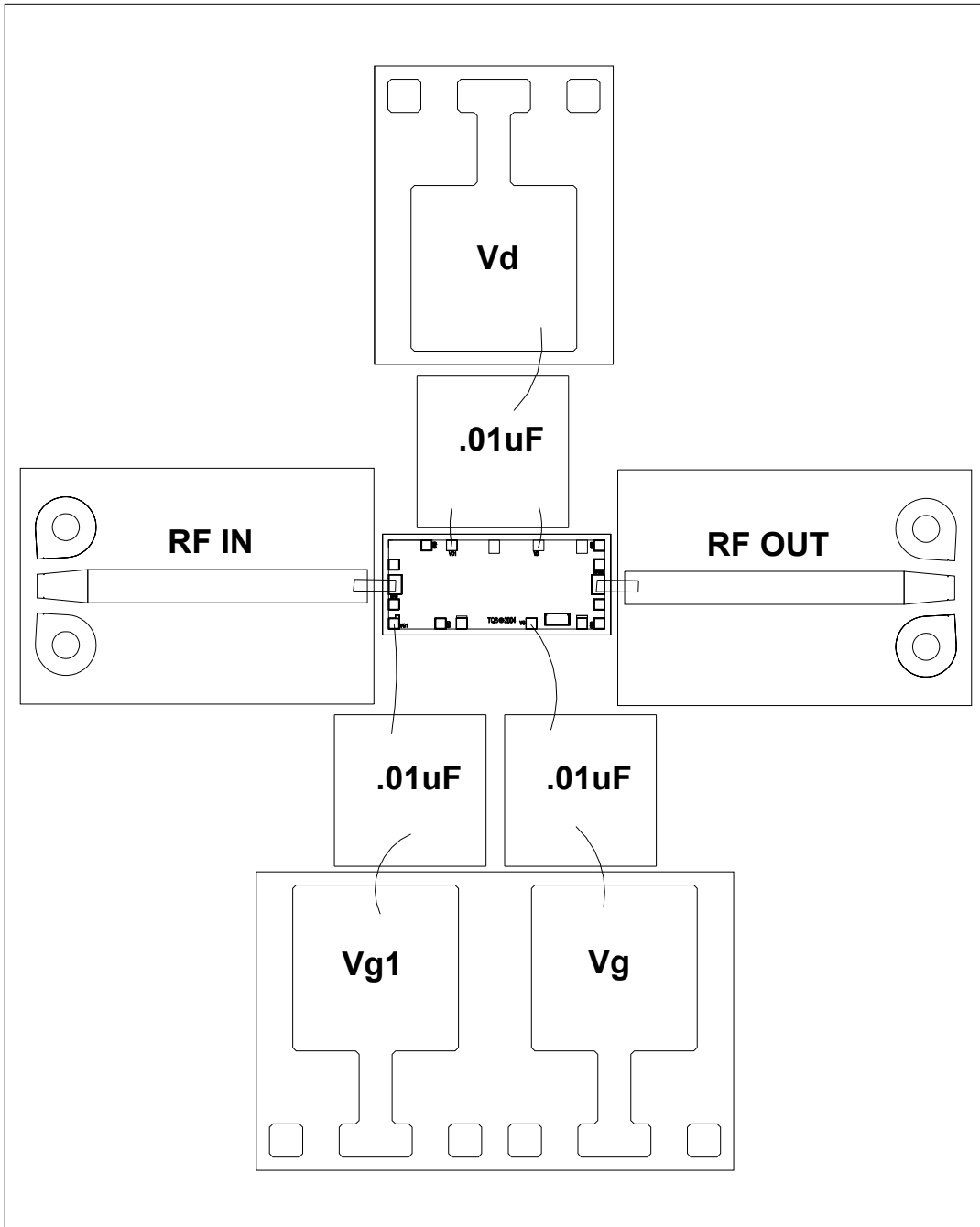

Amplifier

Set Vd = 5.0V

Vary (Vg + Vg1) to achieve Id = 139mA

2x Multiplier

Set Vd = 5.0V

Set Vg1 = -1.1V

Vary Vg to achieve Id = 120mA

GaAs MMIC devices are susceptible to damage from Electrostatic Discharge. Proper precautions should be observed during handling, assembly and test.

**Recommended Chip Assembly Diagram
3x Multiplier**

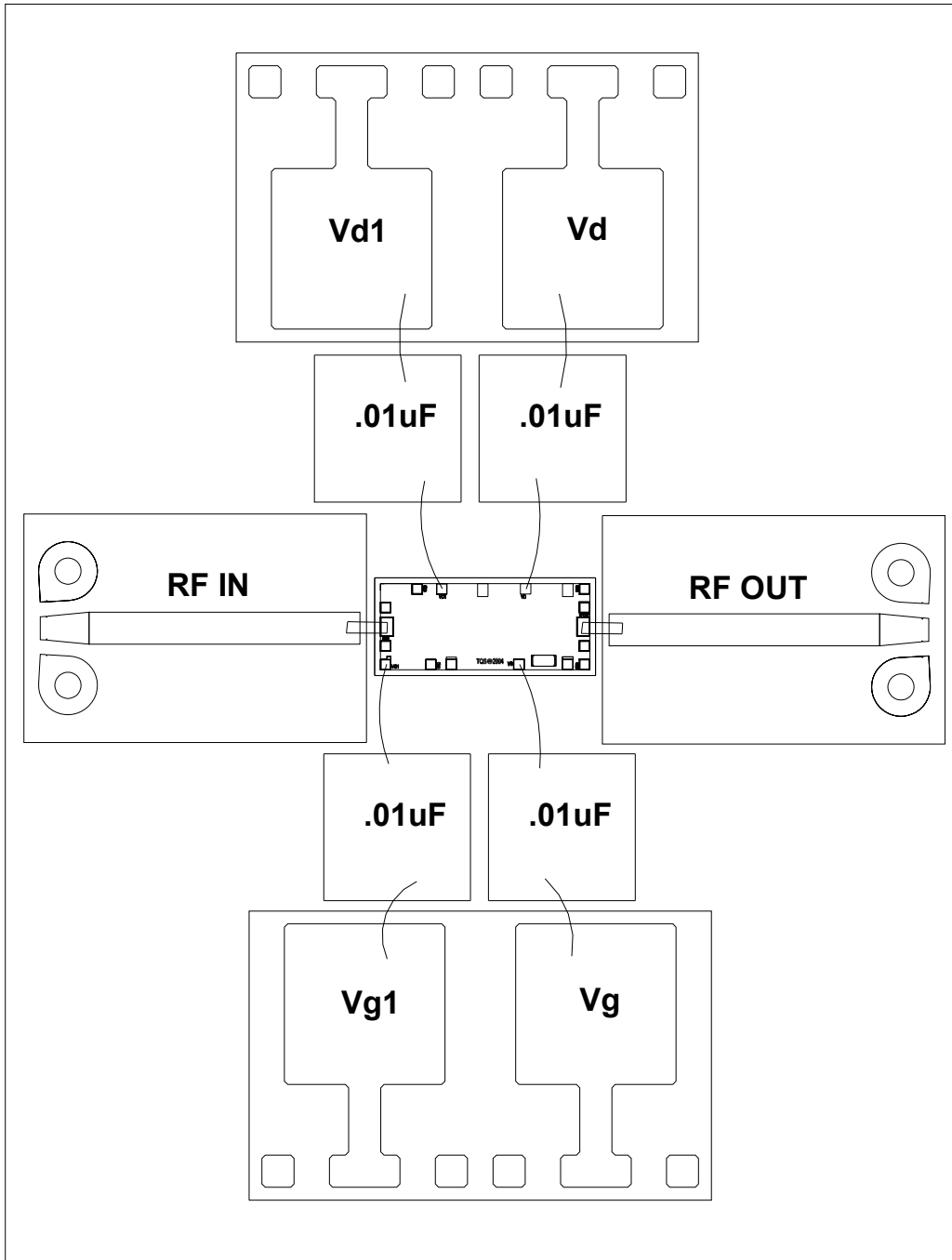

3x Multiplier

Set Vd = 5.0V

Set Vd1 = 1.0V

Vary (Vg + Vg1) to achieve $(I_d + I_{d1}) = 160\text{mA}$

GaAs MMIC devices are susceptible to damage from Electrostatic Discharge. Proper precautions should be observed during handling, assembly and test.

Assembly Process Notes

Reflow process assembly notes:

- Use AuSn (80/20) solder with limited exposure to temperatures at or above 300⁰C (30 seconds max).
- An alloy station or conveyor furnace with reducing atmosphere should be used.
- No fluxes should be utilized.
- Coefficient of thermal expansion matching is critical for long-term reliability.
- Devices must be stored in a dry nitrogen atmosphere.

Component placement and adhesive attachment assembly notes:

- Vacuum pencils and/or vacuum collets are the preferred method of pick up.
- Air bridges must be avoided during placement.
- The force impact is critical during auto placement.
- Organic attachment can be used in low-power applications.
- Curing should be done in a convection oven; proper exhaust is a safety concern.
- Microwave or radiant curing should not be used because of differential heating.
- Coefficient of thermal expansion matching is critical.

Interconnect process assembly notes:

- Thermosonic ball bonding is the preferred interconnect technique.
- Force, time, and ultrasonics are critical parameters.
- Aluminum wire should not be used.
- Maximum stage temperature is 200⁰C.

GaAs MMIC devices are susceptible to damage from Electrostatic Discharge. Proper precautions should be observed during handling, assembly and test.

X-ON Electronics

Largest Supplier of Electrical and Electronic Components

Click to view similar products for [RF Amplifier](#) category:

Click to view products by [Qorvo](#) manufacturer:

Other Similar products are found below :

[A82-1](#) [BGA622H6820XTSA1](#) [BGA 728L7 E6327](#) [BGB719N7ESDE6327XTMA1](#) [HMC397-SX](#) [HMC405](#) [HMC561-SX](#) [HMC8120-SX](#)
[HMC8121-SX](#) [HMC-ALH382-SX](#) [HMC-ALH476-SX](#) [SE2433T-R](#) [SMA3101-TL-E](#) [SMA39](#) [A66-1](#) [A66-3](#) [A67-1](#) [LX5535LQ](#) [LX5540LL](#)
[MAAM02350](#) [HMC3653LP3BETR](#) [HMC549MS8GETR](#) [HMC-ALH435-SX](#) [SMA101](#) [SMA32](#) [SMA411](#) [SMA531](#) [SST12LP19E-QX6E](#)
[WPM0510A](#) [HMC5929LS6TR](#) [HMC5879LS7TR](#) [HMC1126](#) [HMC1087F10](#) [HMC1086](#) [HMC1016](#) [SMA1212](#) [MAX2689EWS+T](#)
[MAAMSS0041TR](#) [MAAM37000-A1G](#) [LTC6430AIUF-15#PBF](#) [CHA5115-QDG](#) [SMA70-2](#) [SMA4011](#) [A231](#) [HMC-AUH232](#) [LX5511LQ](#)
[LX5511LQ-TR](#) [HMC7441-SX](#) [HMC-ALH310](#) [XD1001-BD-000V](#)