

TGA4532

K-Band Power Amplifier

Applications

- Point-to-Point Radio
- Communication

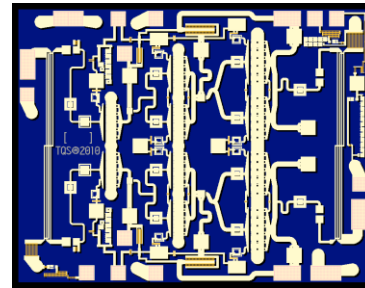

Product Features

- Frequency Range: 17.5 – 20 GHz
- Power: 32.5 dBm Psat, 31.5 dBm P1dB
- Gain: 23 dB
- TOI: 43 dBm @ 22 dBm SCL
- Return Loss: 18 dB
- NF: 6 dB
- Integrated Power Detector
- Bias: Vd = 6 V, Id = 900 mA, Vg = -0.7 V Typical
- Dimensions: 2.4 x 1.9 x 0.1 mm

Functional Block Diagram

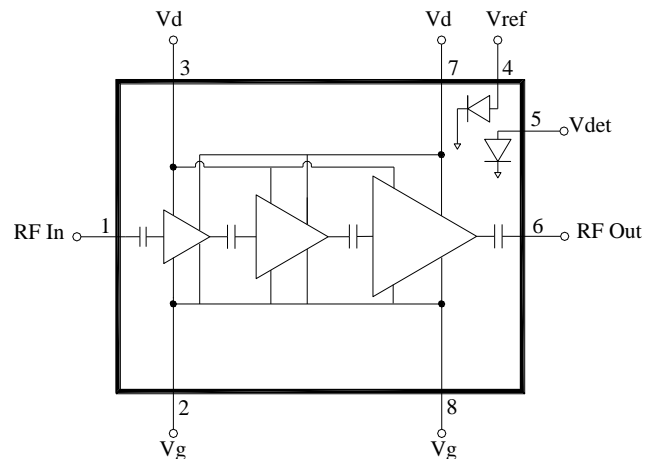

General Description

The TriQuint TGA4532 is a K-Band Power Amplifier. The TGA4532 operates from 17.5 to 20 GHz and is designed using TriQuint's power pHEMT production process.

The TGA4532 typically provides 31.5 dBm of output power at 1dB gain compression with small signal gain of 23 dB. Third Order Intercept is 43 dBm at 22 dBm SCL.

The TGA4532 is ideally suited for Point-to-Point Radio, and K-band communications.

Lead-free and RoHS compliant

Bond Pad Configuration

Bond Pad #	Symbol
1	RF In
2, 8	Vg
3, 7	Vd
4	Vref
5	Vdet
6	RF Out

Ordering Information

Part No.	ECCN	Description
TGA4532	EAR99	K-band Power Amplifier

Standard order qty = 100 pieces.

Specifications

Absolute Maximum Ratings

Parameter	Rating
Drain to Gate Voltage, Vd - Vg	10 V
Drain Voltage, Vd	+6.5 V
Gate Voltage, Vg	-4 to 0 V
Drain Current, Id	1960 mA
Gate Current, Ig	-8.2 to 113 mA
Power Dissipation, Pdiss	12.7 W
RF Input Power, CW, 50Ω, T = 25°C	26 dBm
Channel Temperature, Tch	200 °C
Mounting Temperature (30 Seconds)	320 °C
Storage Temperature	-40 to 150 °C

Operation of this device outside the parameter ranges given above may cause permanent damage. These are stress ratings only, and functional operation of the device at these conditions is not implied.

Recommended Operating Conditions

Parameter	Min	Typical	Max	Units
Vd		6		V
Id		900		mA
Id_drive (Under RF Drive)		1200		mA
Vg		-0.7		V

Electrical specifications are measured at specified test conditions. Specifications are not guaranteed over all recommended operating conditions.

Electrical Specifications

Test conditions unless otherwise noted: 25°C, Vd = 6 V, Id = 900 mA, Vg = -0.7 V Typical.

Parameter	Min	Typical	Max	Units
Operational Frequency Range	17.7		19.7	GHz
Gain	21	23		dB
Input Return Loss		-18	-14	dB
Output Return Loss		-18	-14	dB
Output Power @ Saturation		32.5		dBm
Output Power @ 1 dB Gain Compression	30	31.5		dBm
Output TOI @ 22 dBm SCL	40	43		dBm
Noise Figure		6		dB
Gain Temperature Coefficient		-0.025		dB/°C
Power Temperature Coefficient		-0.005		dBm/°C

Specifications (cont.)

Thermal and Reliability Information

Parameter	Condition	Rating
Thermal Resistance, θ_{JC} , measured to back of package	Tbase = 70 °C	$\theta_{JC} = 8.51$ °C/W
Channel Temperature (Tch), and Median Lifetime (Tm)	Tbase = 70 °C, Vd = 6 V, Id = 900 mA, Pdiss = 5.4 W	Tch = 116 °C Tm = 6.3 E+7 Hours
Channel Temperature (Tch), and Median Lifetime (Tm) Under RF Drive	Tbase = 70 °C, Vd = 6 V, Id = 1200 mA, Pout = 32.5 dBm, Pdiss = 5.4 W	Tch = 116 °C Tm = 6.3 E+7 Hours

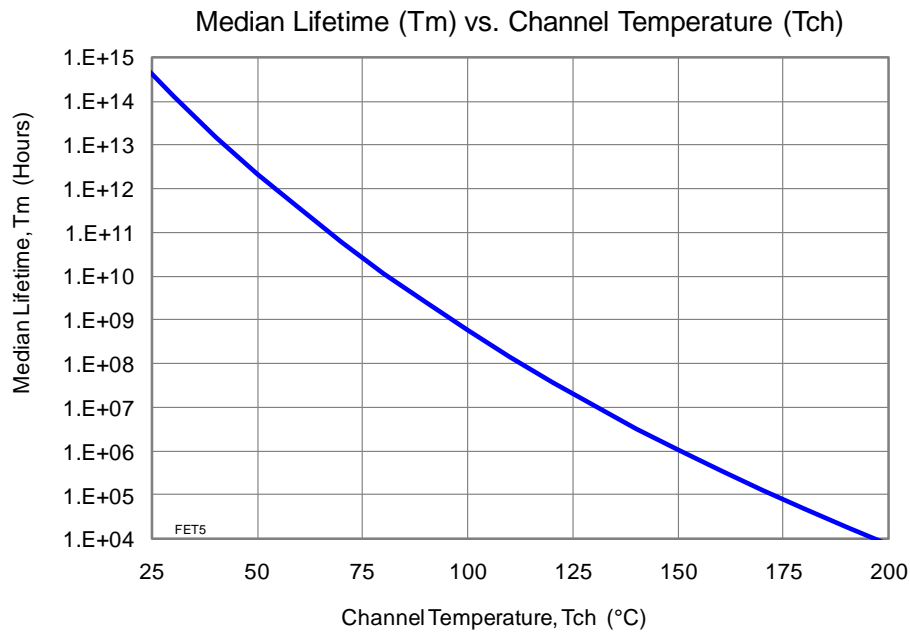

Typical Performance

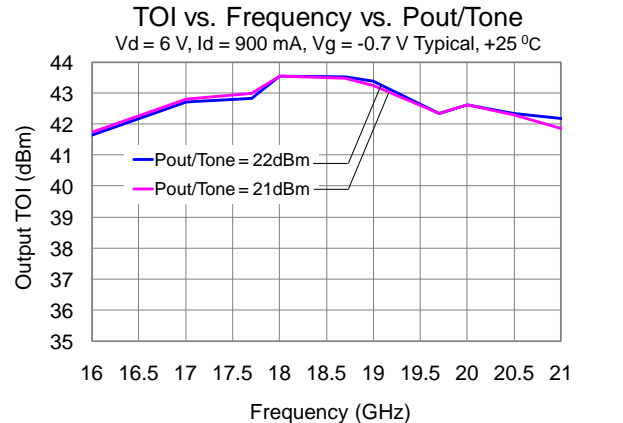
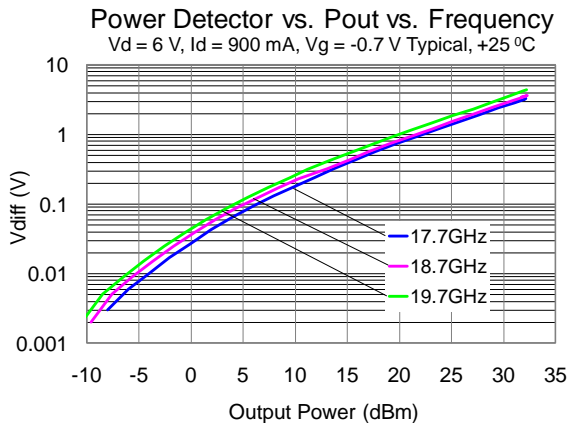
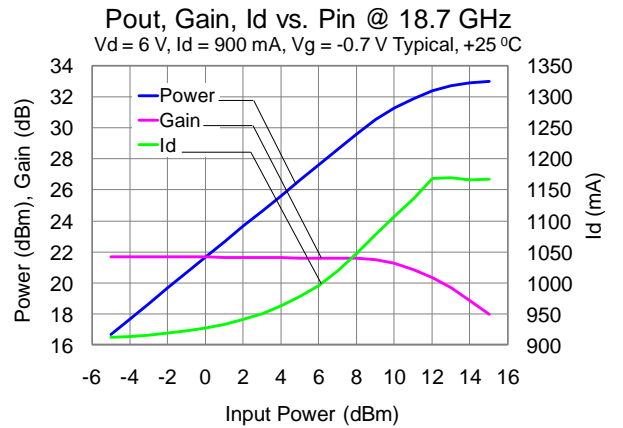
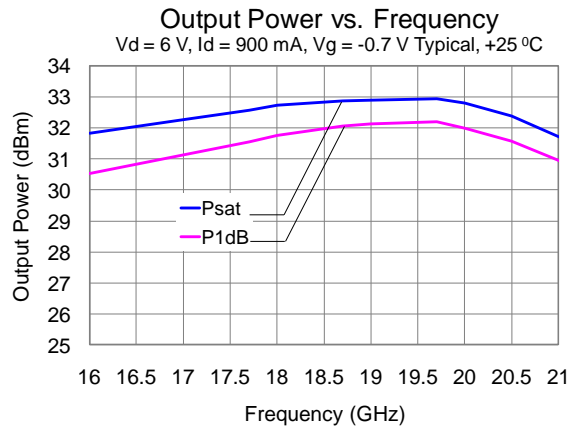
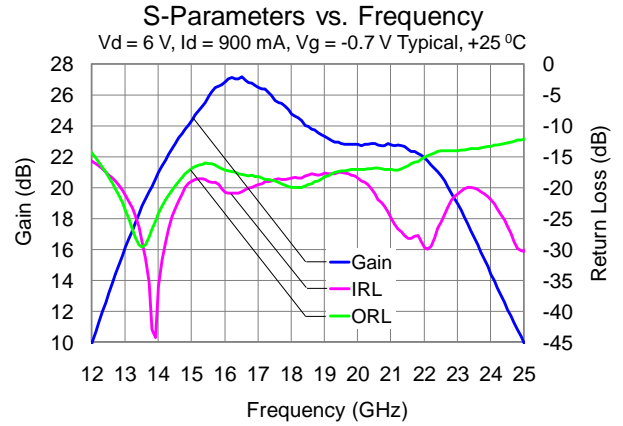
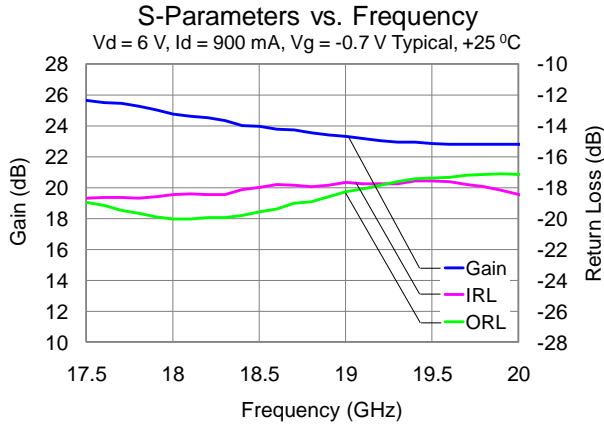

Typical Performance (cont.)

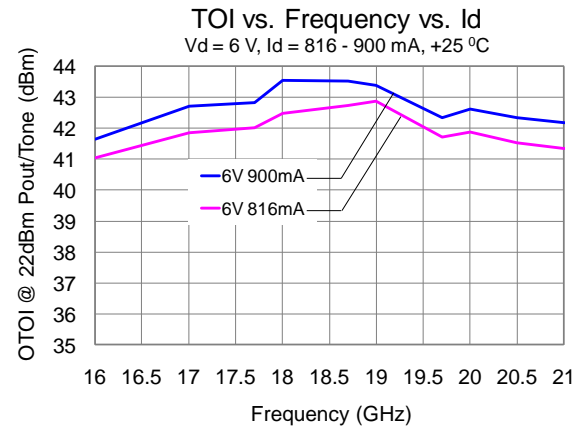
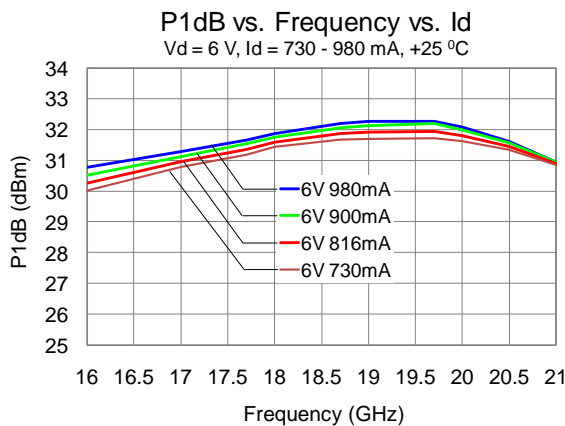
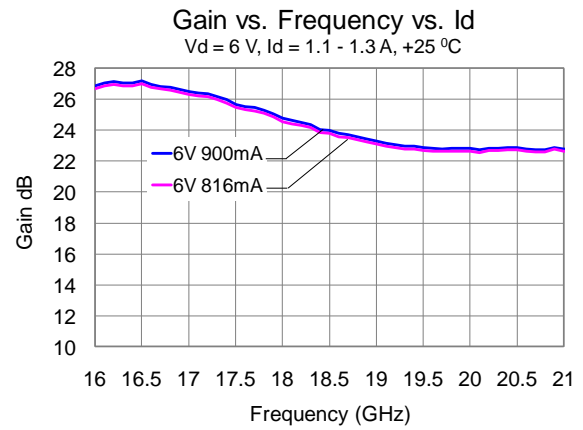
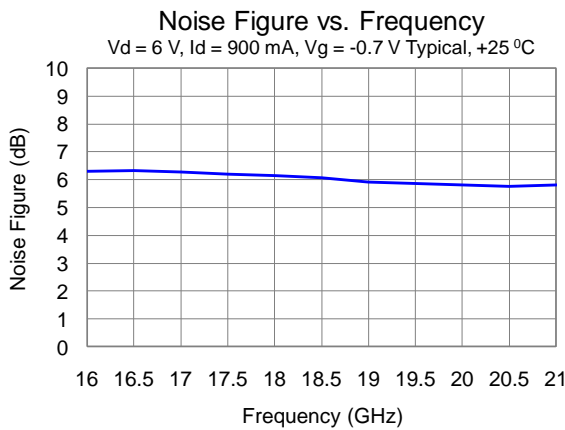
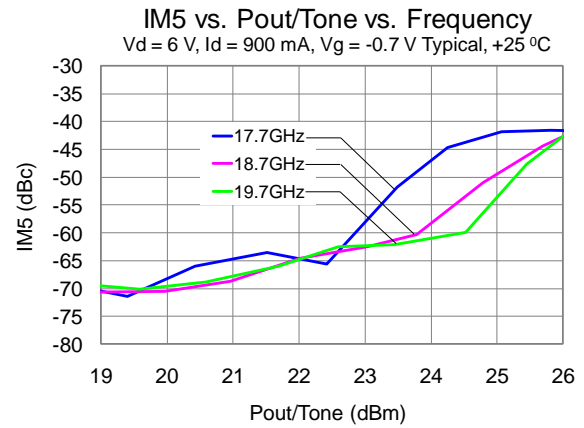
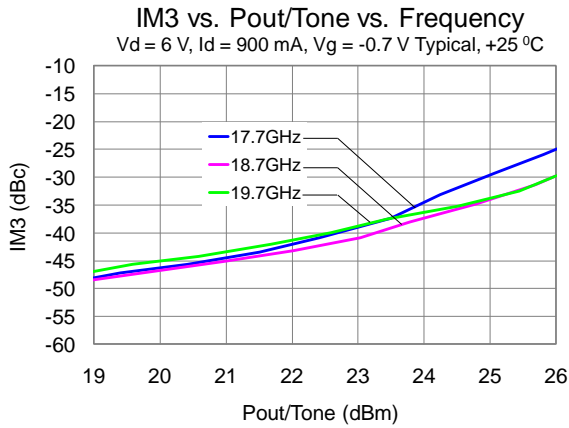

Typical Performance (cont.)

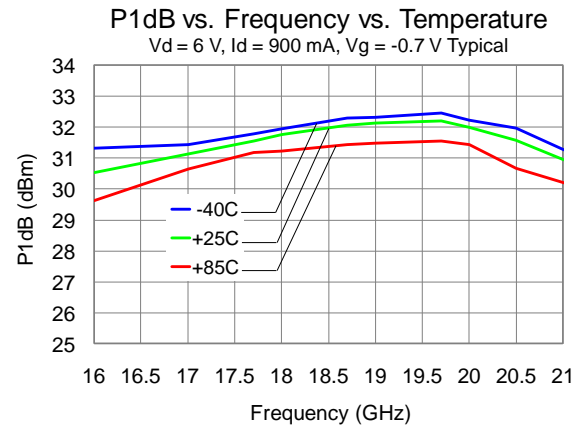
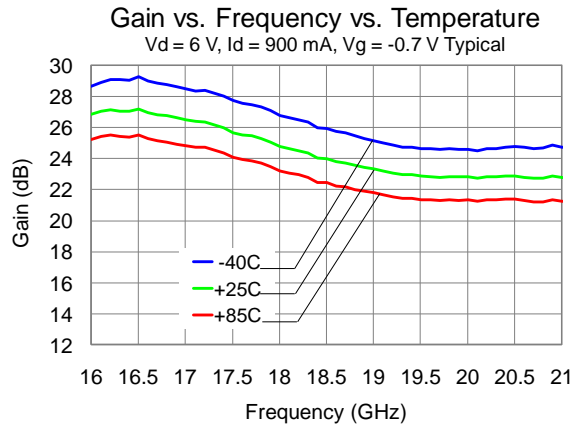

Application Circuit

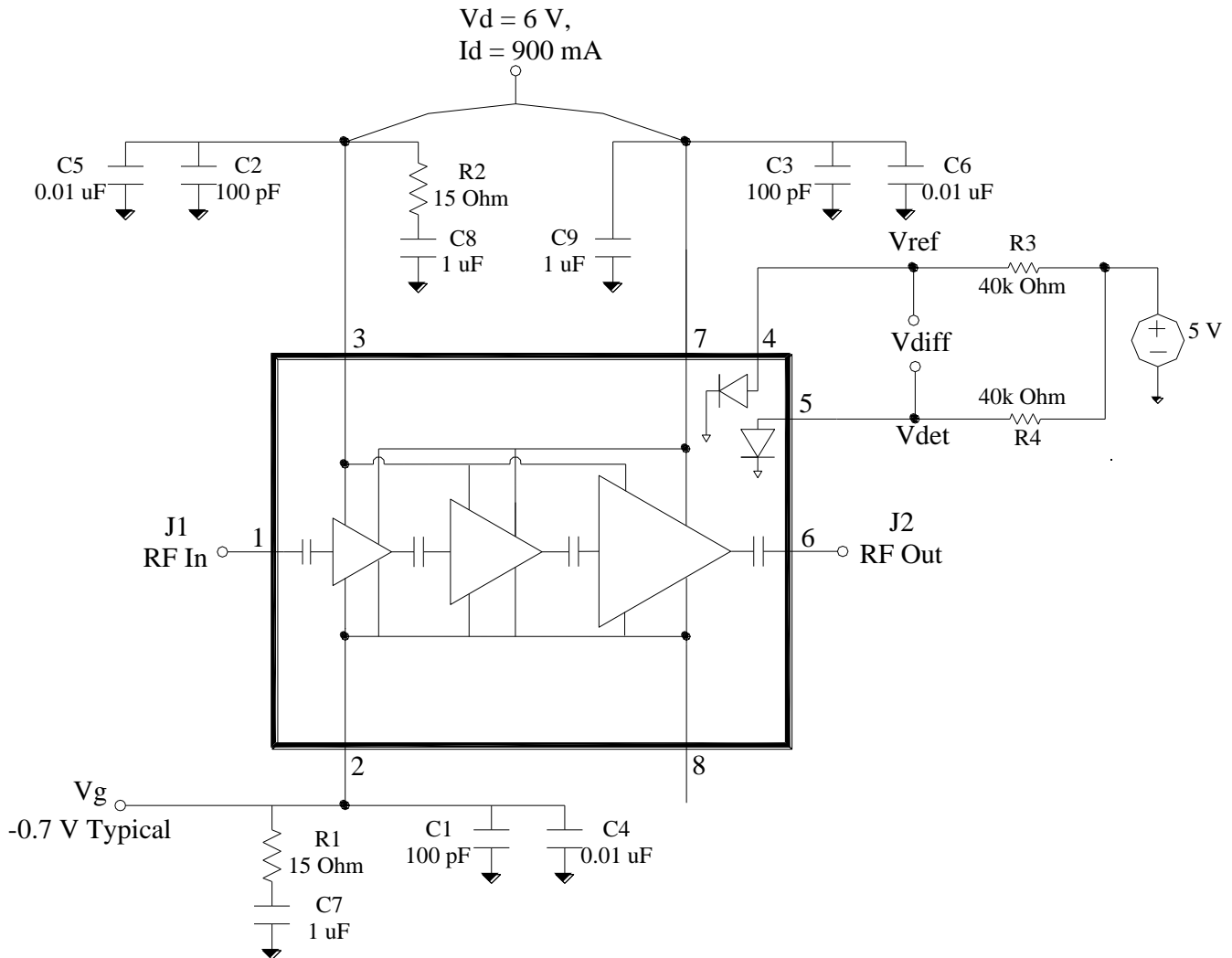

Vg can be biased from either side (bond pad 2 or bond pad 8), and the non-biased side can be left open.
Vd must be biased from both sides (bond pad 3 and bond pad 7).

Bias-up Procedure

- Vg set to -1.5 V
- Vd set to +6 V
- Adjust Vg more positive until quiescent Id is 900 mA.
This will be ~ Vg = -0.7 V
- Apply RF signal to RF Input

Bias-down Procedure

- Turn off RF supply
- Reduce Vg to -1.5V. Ensure Id ~ 0 mA
- Turn Vd to 0 V
- Turn Vg to 0 V

Bond Pad Description

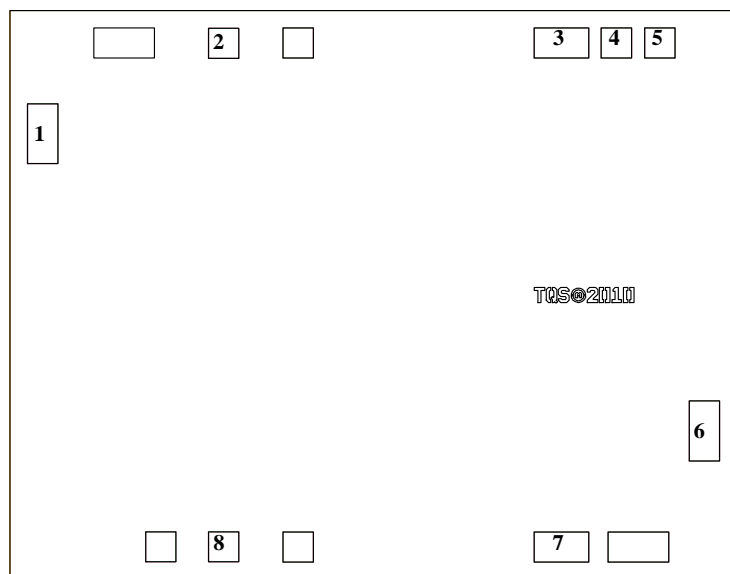

Bond Pad	Symbol	Description
1	RF In	Input, matched to 50 ohms
2, 8	Vg	Gate voltage. ESD protection included; Bias network is required; can be biased from either side (bond pad 2 or bond pad 8), and non-biased side can be left opened; see Application Circuit on page 7 as an example.
3, 7	Vd	Drain voltage. Bias network is required; must be biased from both sides; see Application Circuit on page 7 as an example.
4	Vref	Reference diode output voltage.
5	Vdet	Detector diode output voltage. Varies with RF output power.
6	RF Out	Output, matched to 50 ohms

Assembly Drawing

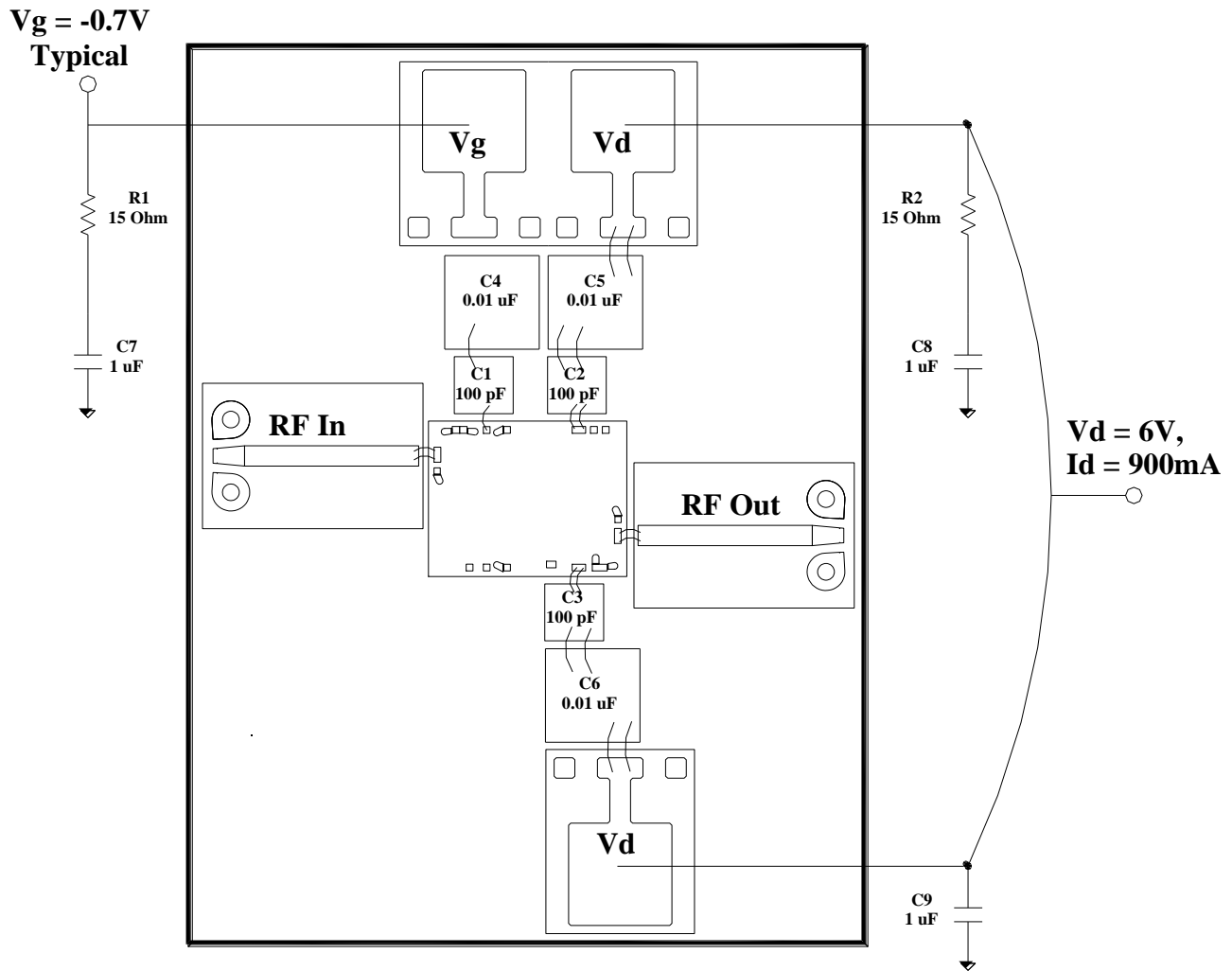

Bill of Material

Ref Des	Value	Description	Manufacturer	Part Number
C1, C2, C3	100 pF	Cap, 50V, 25%, Single Layer Cap	various	
C4, C5, C6	0.01 uF	Cap, 50V, 10%, SMD	various	
C7, C8, C9	1 uF	Cap, 50V, 5%	various	
R1, R2	15 Ohms	Res, 1/4W, 5%	various	

Mechanical Information

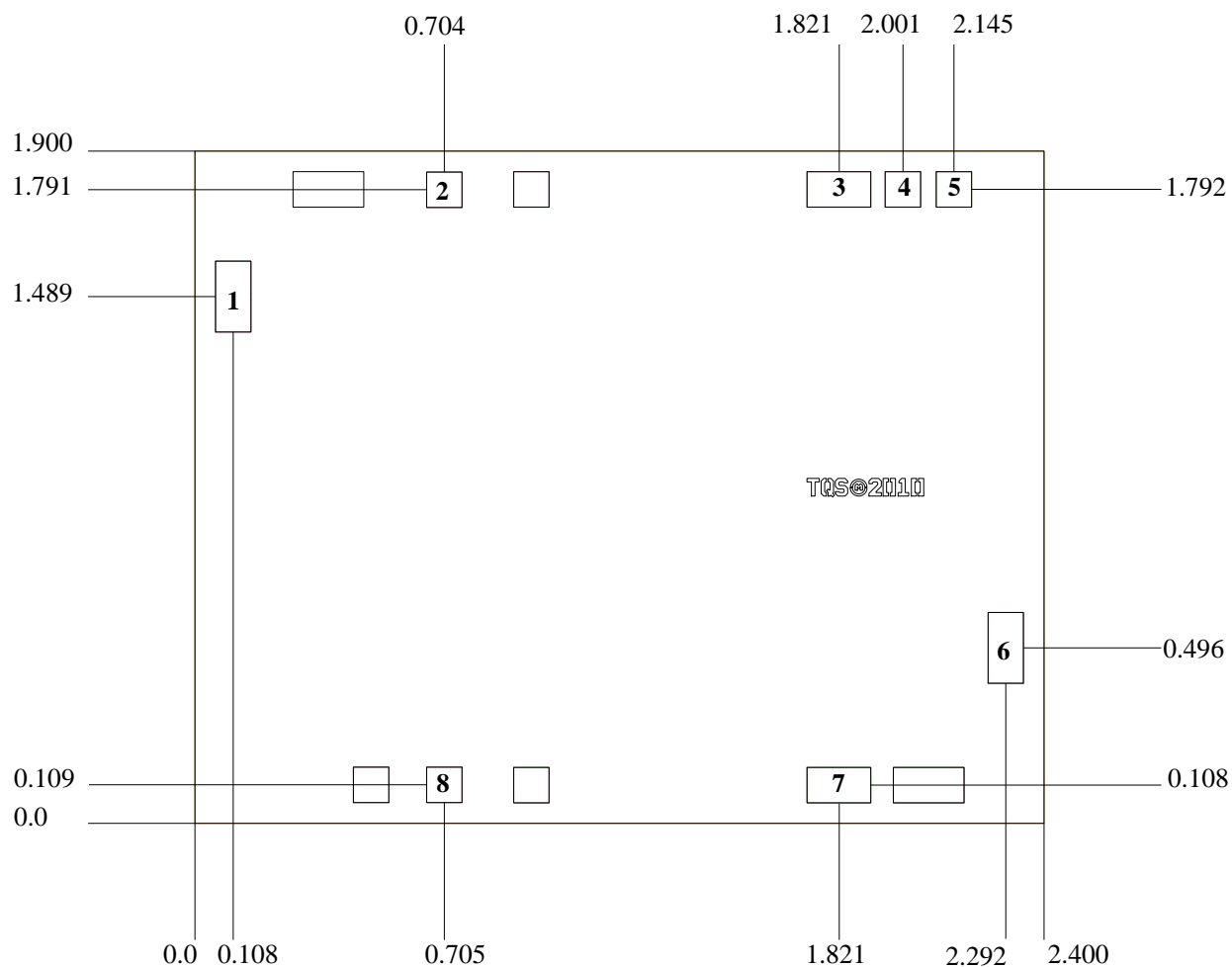

Unit: millimeters
 Thickness: 0.10
 Die x, y size tolerance: +/- 0.050
 Chip edge to bond pad dimensions are shown to center of pad
 Ground is backside of die

Bond Pad	Symbol	Pad Size
1	RF In	0.100 x 0.200
2, 8	Vg	0.100 x 0.100
3, 7	Vd	0.180 x 0.100
4	Vred	0.100 x 0.100
5	Vdet	0.100 x 0.100
6	RF Out	0.100 x 0.200

Product Compliance Information

ESD Information



Caution! ESD-Sensitive Device

ESD Rating: 1A
Value: Passes $\geq 250V$ min.
Test: Human Body Model (HBM)
Standard: JEDEC Standard JESD22-A114

ECCN

US Department of Commerce EAR99

Solderability

This part is compliant with EU 2002/95/EC RoHS directive (Restrictions on the Use of Certain Hazardous Substances in Electrical and Electronic Equipment).

This product also has the following attributes:

- Lead Free
- Halogen Free (Chlorine, Bromine)
- Antimony Free
- TBBP-A ($C_{15}H_{12}Br_4O_2$) Free
- PFOS Free
- SVHC Free

Assembly Notes

Component placement and adhesive attachment assembly notes:

- Vacuum pencils and/or vacuum collets are the preferred method of pick up.
- Air bridges must be avoided during placement.
- The force impact is critical during auto placement.
- Organic attachment (i.e. epoxy) can be used in low-power applications.
- Curing should be done in a convection oven; proper exhaust is a safety concern.

Reflow process assembly notes:

- Use AuSn (80/20) solder and limit exposure to temperatures above 300°C to 3-4 minutes, maximum.
- An alloy station or conveyor furnace with reducing atmosphere should be used.
- Do not use any kind of flux.
- Coefficient of thermal expansion matching is critical for long-term reliability.
- Devices must be stored in a dry nitrogen atmosphere.

Interconnect process assembly notes:

- Thermosonic ball bonding is the preferred interconnect technique.
- Force, time, and ultrasonics are critical parameters.
- Aluminum wire should not be used.
- Devices with small pad sizes should be bonded with 0.0007-inch wire.

TGA4532

K-Band Power Amplifier



Contact Information

For the latest specifications, additional product information, worldwide sales and distribution locations, and information about TriQuint:

Web: www.triquint.com
Email: info-sales@tqs.com

Tel: +1.972.994.8465
Fax: +1.972.994.8504

For technical questions and application information:

Email: info-networks@tqs.com

Important Notice

The information contained herein is believed to be reliable. TriQuint makes no warranties regarding the information contained herein. TriQuint assumes no responsibility or liability whatsoever for any of the information contained herein. TriQuint assumes no responsibility or liability whatsoever for the use of the information contained herein. The information contained herein is provided "AS IS, WHERE IS" and with all faults, and the entire risk associated with such information is entirely with the user. All information contained herein is subject to change without notice. Customers should obtain and verify the latest relevant information before placing orders for TriQuint products. The information contained herein or any use of such information does not grant, explicitly or implicitly, to any party any patent rights, licenses, or any other intellectual property rights, whether with regard to such information itself or anything described by such information.

TriQuint products are not warranted or authorized for use as critical components in medical, life-saving, or life-sustaining applications, or other applications where a failure would reasonably be expected to cause severe personal injury or death.

Copyright © 2011 TriQuint Semiconductor, Inc. All rights reserved.

X-ON Electronics

Largest Supplier of Electrical and Electronic Components

Click to view similar products for [RF Amplifier](#) category:

Click to view products by [Qorvo](#) manufacturer:

Other Similar products are found below :

[A82-1](#) [BGA622H6820XTSA1](#) [BGA 728L7 E6327](#) [BGB719N7ESDE6327XTMA1](#) [HMC397-SX](#) [HMC405](#) [HMC561-SX](#) [HMC8120-SX](#)
[HMC8121-SX](#) [HMC-ALH382-SX](#) [HMC-ALH476-SX](#) [SE2433T-R](#) [SMA3101-TL-E](#) [SMA39](#) [A66-1](#) [A66-3](#) [A67-1](#) [A81-2](#) [LX5535LQ](#)
[LX5540LL](#) [MAAM02350](#) [HMC3653LP3BETR](#) [HMC549MS8GETR](#) [HMC-ALH435-SX](#) [SMA101](#) [SMA32](#) [SMA411](#) [SMA531](#)
[SST12LP19E-QX6E](#) [WPM0510A](#) [HMC5929LS6TR](#) [HMC5879LS7TR](#) [HMC1087F10](#) [HMC1086](#) [HMC1016](#) [SMA1212](#) [MAX2689EWS+T](#)
[MAAMSS0041TR](#) [MAAM37000-A1G](#) [LTC6430AIUF-15#PBF](#) [SMA70-2](#) [SMA4011](#) [A231](#) [HMC-AUH232](#) [LX5511LQ](#) [LX5511LQ-TR](#)
[HMC7441-SX](#) [HMC-ALH310](#) [XD1001-BD-000V](#) [A4011](#)