

Product Description

The Qorvo TGC4403-SM packaged MMIC combines a frequency doubler with a 3-stage amplifier, operating at input frequencies of 8 – 15 GHz. With greater than 30 dBc isolation between the input and doubler frequency, the TGC4403-SM achieves 20 dBm output power, with 2 dBm input power. This performance makes this doubler ideally suited for Point to Point Radios and Ka-Band satellite ground terminal applications. The TGC4403-SM provides the frequency doubling function in a compact 4 mm x 4 mm package foot print.

Lead-free and RoHS compliant.



16-pin 4x4 mm QFN package

Function Block Diagram

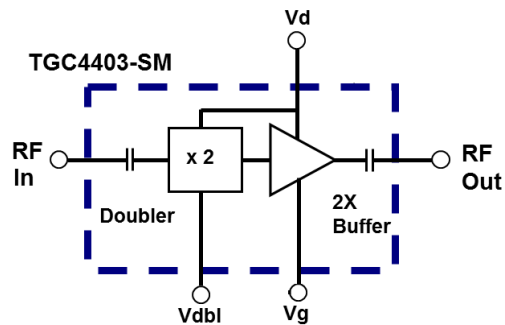

Product Features

- RF Output Frequency Range: 16 – 30 GHz
- Input Frequency Range: 8 – 15 GHz
- Output Power: 20 dBm Nominal
- Gain Power: 18 dBm
- Input Frequency Isolation: 30 dBc
- Bias: $V_D = 5V$, $I_{DQ} = 150mA$, $V_{DBL} = -0.8V$, $V_G = -0.5V$ Typical.
- Package Dimensions: 4.0 x 4.0 x 0.9 mm

Applications

- Point-to-Point Radio
- Ka Band Sat-Com

Ordering Information

Part No.	Description
TGC4403-SM	8 – 15 GHz Packaged Doubler with Amplifier

Absolute Maximum Ratings

Parameter	Rating
Drain to Gate Voltage ($V_D - V_G$)	12 V
Drain Voltage (V_D)	8 V
Doubler Voltage Range (V_{DBL})	-5 to 0 V
Gate Voltage Range (V_G)	-5 to 0 V
Drain Current (I_D)	280 mA
Gate Current Range (I_G)	-1 to 23 mA
Doubler Current Range (I_{DBL})	-0.6 to 16.8 mA
RF Input Power, CW, T = 25 °C	18.2 dBm
Power Dissipation (P_{DISS}), 70 °C	1.42 W
Channel Temperature, T _{ch}	150 °C
Mounting Temperature (30 sec)	260 °C
Storage Temperature	-65 to 150 °C

Operation of this device outside the parameter ranges given above may cause permanent damage. These are stress ratings only, and functional operation of the device at these conditions is not implied.

Recommended Operating Conditions

Parameter	Min	Typ	Max	Units
Operating Temperature Range	-40	+25	+85	°C
V_D		5		V
I_{DQ}		150		mA
I_{D_Drive} @ RF Input = 2dBm		170		mA
V_G		-0.5		V
V_{DBL}		-0.8		mA

Electrical specifications are measured at specified test conditions. Specifications are not guaranteed over all recommended operating conditions.

Electrical Specifications

Test conditions unless otherwise noted: 25 °C, $V_D = 5$ V, $I_{DQ} = 150$ mA, $V_G = -0.5$ V Typical, $V_{DBL} = -0.8$ V Fixed.

Parameter	Conditions	Min	Typ	Max	Units
Input RF Frequency Range		8		15	GHz
Conversion Gain (CG) @ RF In = 2 dBm	Input Freq.= 8 – 14.5 GHz Output Freq.= 16 – 29 GHz	14	18		dB
	Input Freq. = 15 GHz Output Freq. = 30 GHz	12	16		dB
Input Return Loss (IRL)	Freq. = 8 – 15 GHz		6		dB
Output Return Loss (ORL)	Freq. = 16 – 30 GHz		4		dB
Output Power @ RF In = 2 dBm	Freq. = 16 – 30 GHz	16	20		dBm
Isolation, Fundamental (Isol_1x)	Input Freq.= 8 – 14.5 GHz Output Freq.= 8 – 14.5 GHz	11	30		dBc
Isolation, 3 rd Harmonic (Isol_3x)	Input Freq.= 8 – 10.5 GHz Output Freq.= 24 – 31.5 GHz	1	10		dBc

Thermal and Reliability Information

Parameter	Conditions	Rating
Thermal Resistance, θ_{JC} ⁽¹⁾	Tbase = 70 °C	θ_{JC} = 56.3 °C/W
Channel Temperature (T _{CH}), (No RF drive) Median Lifetime (T _m)	V _D = 5 V, I _{DQ} = 150 mA P _{DISS} = 0.75 W	T _{ch} = 112 °C T _m = 3.47E+7 Hours
Channel Temperature (T _{CH}), (Under RF Drive) Median Lifetime (T _m)	V _D = 5 V, I _{D_Drive} = 170 mA P _{OUT} = 22 dBm P _{DISS} = 0.69 W	T _{ch} = 109 °C T _m = 4.6E+7 Hours

Notes:

1. Thermal resistance measured to back of package.

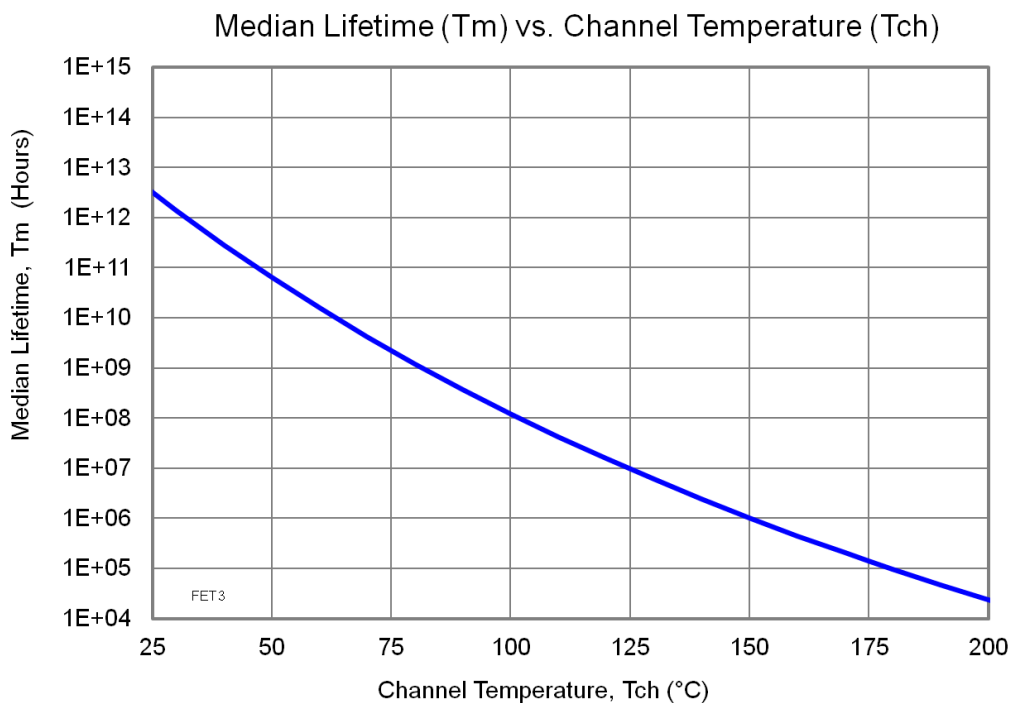

Performance Plots

Bias Conditions: $V_D = 5\text{ V}$, $I_{DQ} = 150\text{ mA}$, $V_{DBL} = -0.8\text{ V}$ Typical, Temp. = $25\text{ }^\circ\text{C}$

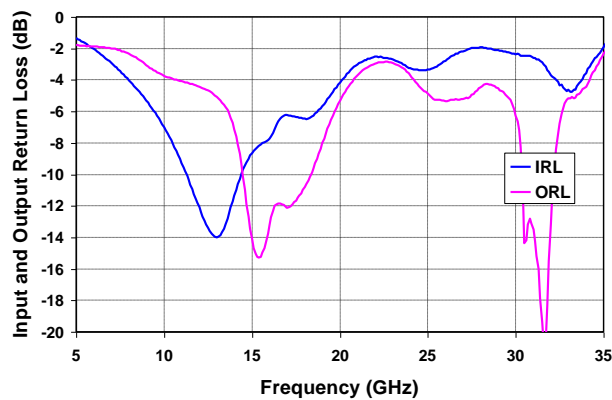
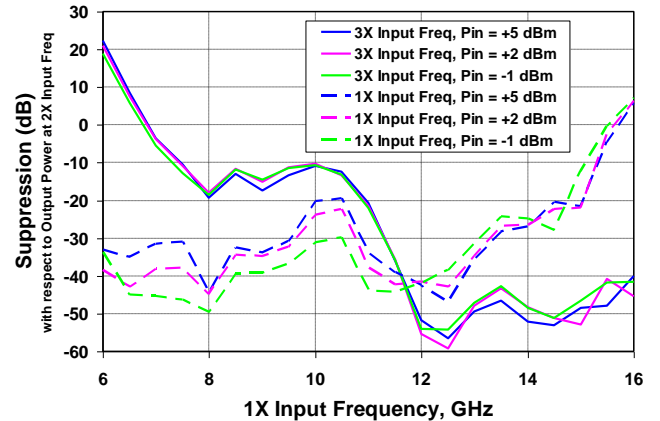
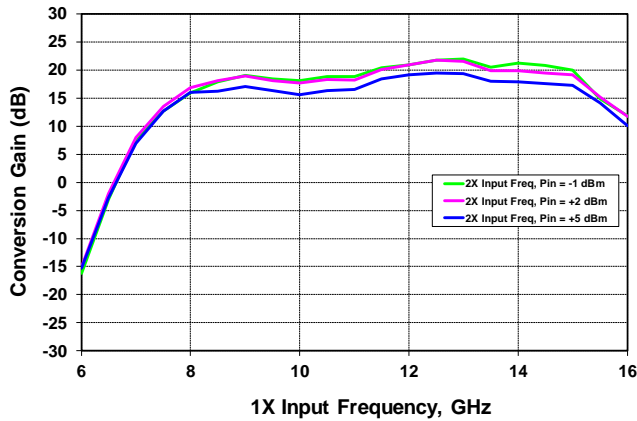
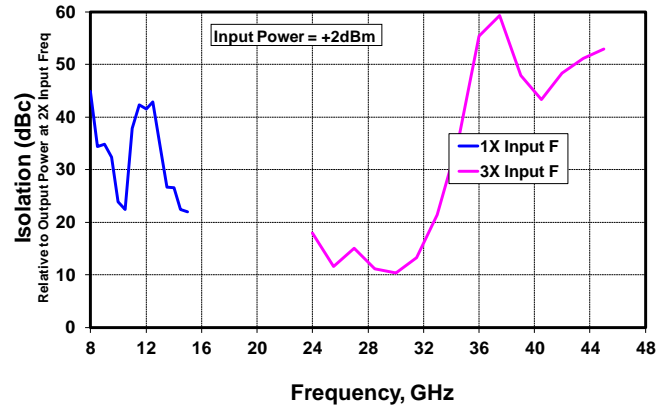
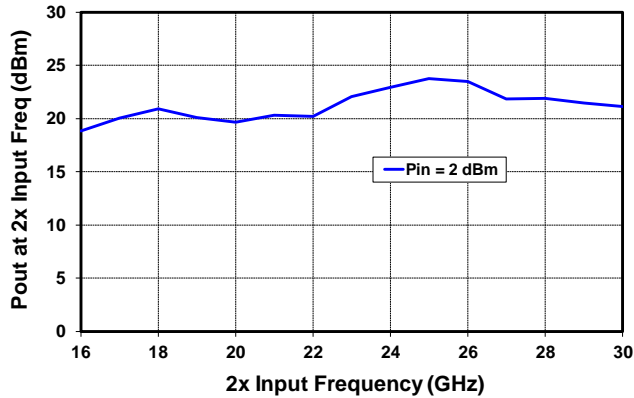

Pin Configuration and Description

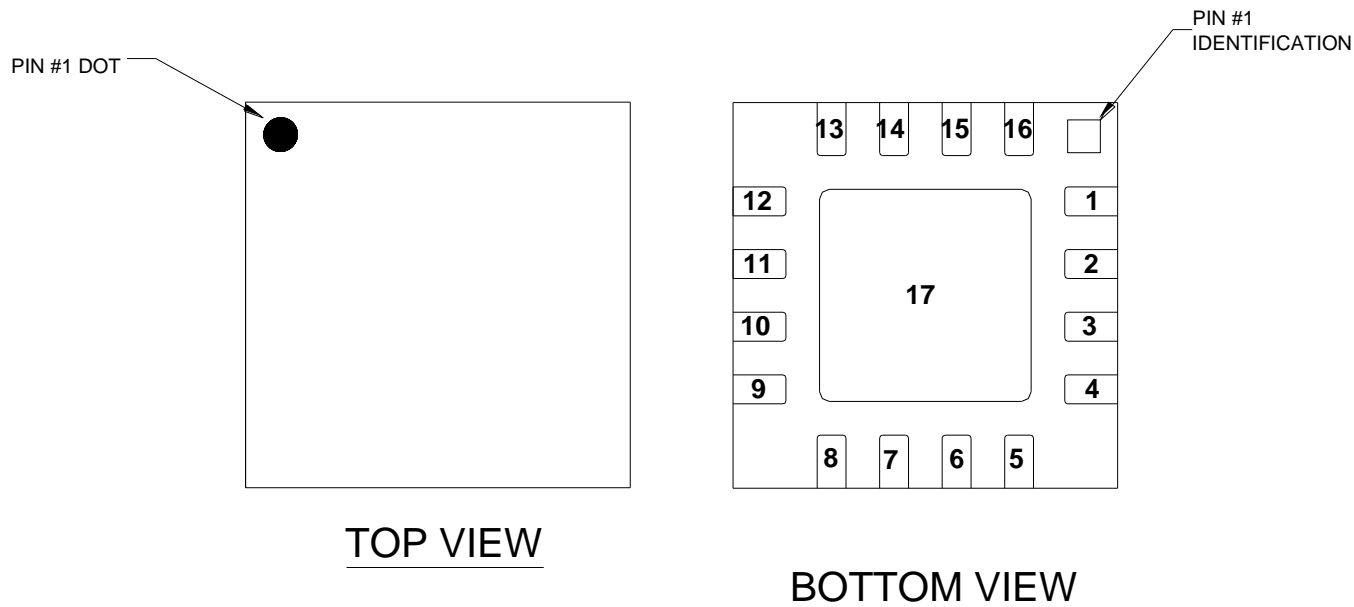

Pin No.	Label	Description
1, 2, 4, 7, 8, 9, 11, 12, 13, 15, 16	N/C	No internal connection; must be grounded on PCB.
3	RF IN	RF Input matched to 50 ohms, AC Coupled.
5	VDBL	Doubler Gate Voltage. Bias network is required; see Application Circuit on page 6 as an example.
6	VG	Gate Voltage. Bias network is required; see Application Circuit on page 6 as an example.
10	RF OUT	RF Output, matched to 50 ohms, AC coupled.
14	VD	Drain Voltage. Bias network is required; see Application Circuit on page 6 as an example.
17	GND	Internal Grounding; must be grounded on PCB.

Applications Circuit

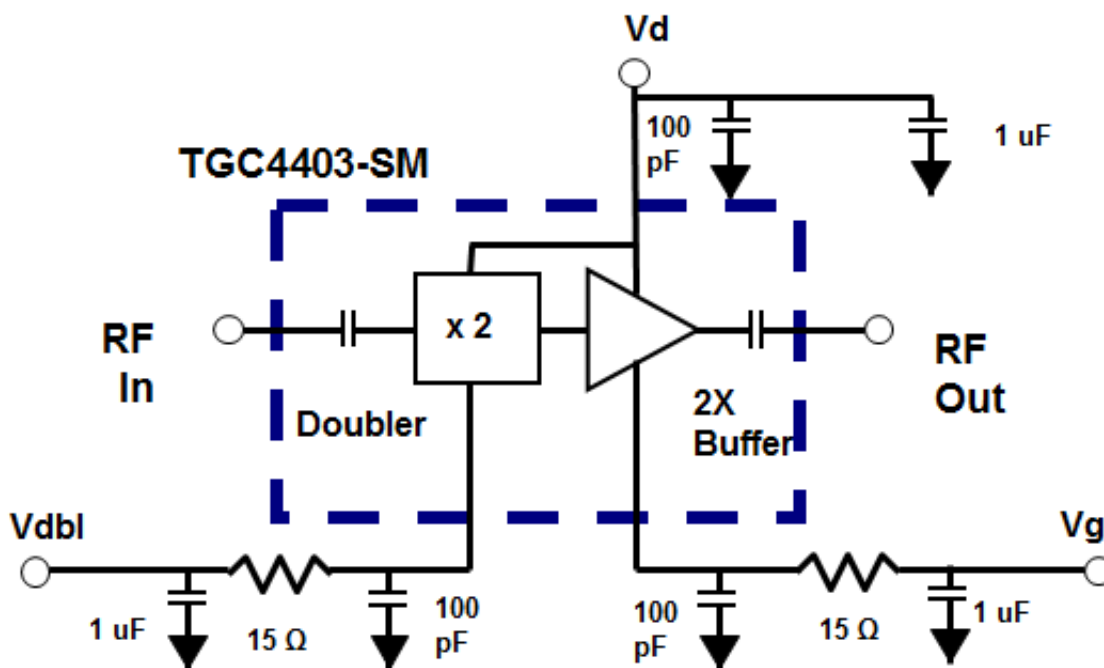

Bias-up Procedure	Bias-down Procedure
Set V_G to -5.0 V	Turn off RF signal
Set V_D to $+5$ V	Reduce V_G to -5.0 V. Ensure $I_{DQ} \sim 0$ mA
Set V_{DBL} to -0.8 V	Turn V_{DBL} to 0 V
Adjust V_G more positive until $I_{DQ} = 150$ mA ($V_G \sim -0.5$ V Typical)	Turn V_D to 0 V
Apply RF Signal	Turn V_G to 0 V

Evaluation Board (EVB) Assembly Layout

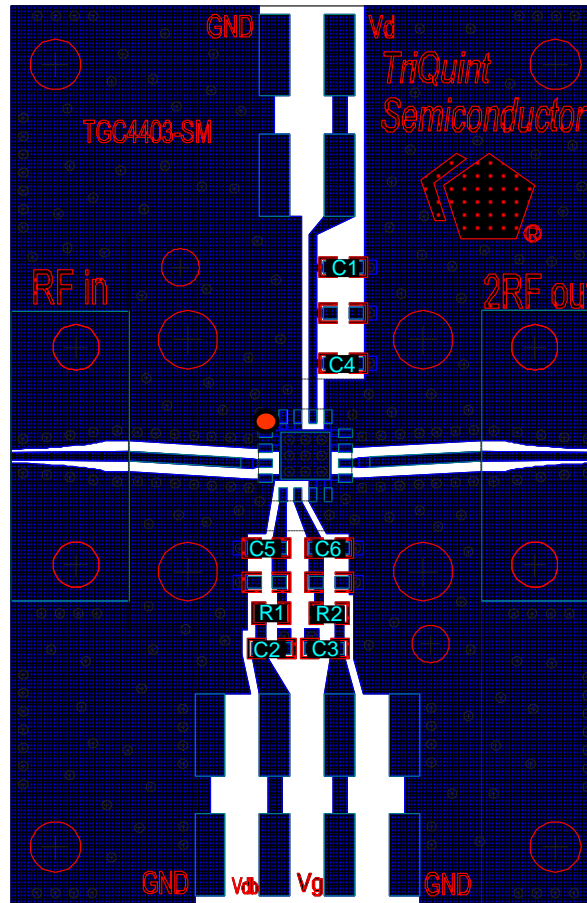

Bill of Material

Ref Des	Value	Description	Manufacturer	Part Number
C1, C2, C3	1 μ F	Cap, 0402, 25V, 5%,	Various	
C7, C8, C9	100 pF	Cap, 0402, 25V, 5%	Various	
R1, R2	15 ohm	Res, 0402, 1%, 0.05W	Various	

Package Marking and Dimensions

All dimensions are in millimeters.

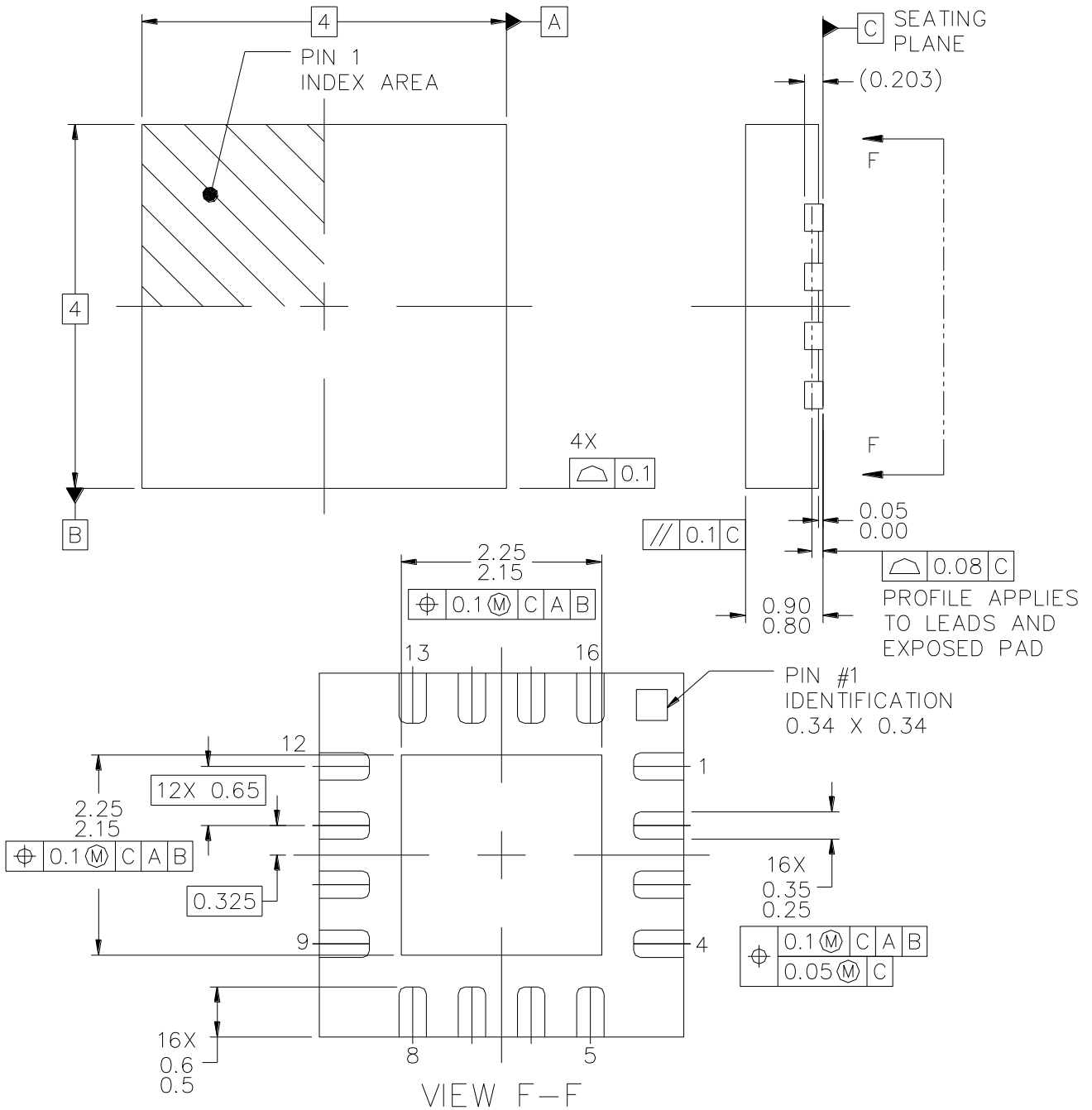

Solderability

1. Compatible with the latest version of J-STD-020, Lead-free solder, 260 °C
2. The use of no-clean solder to avoid washing after soldering is recommended.
3. Do not expose the package lid to temperatures > 280 °C

Recommended Soldering Temperature Profile

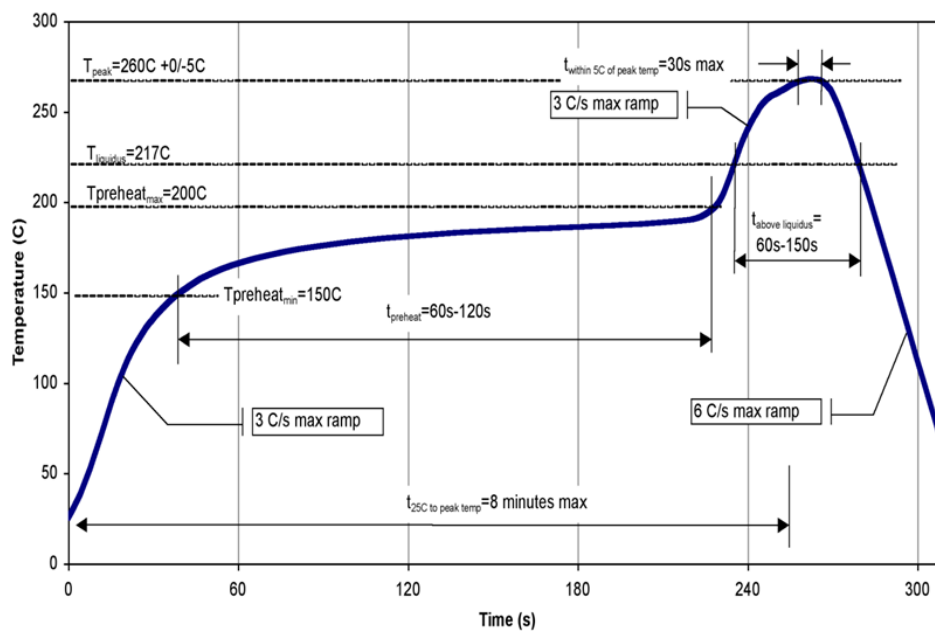

Handling Precautions

Parameter	Rating	Standard
ESD – Human Body Model (HBM)	Class 1A	ESDA / JEDEC JS-001-2012
MSL – Moisture Sensitivity Level	Level 1	IPC/JEDEC J-STD-020



Caution!
ESD-Sensitive Device

RoHS Compliance

This product is compliant with the 2011/65/EU RoHS directive (Restrictions on the Use of Certain Hazardous Substances in Electrical and Electronic Equipment), as amended by Directive 2015/863/EU. This product also has the following attributes:

- Lead Free
- Halogen Free (Chlorine, Bromine)
- Antimony Free
- TBBP-A (C₁₅H₁₂Br₄O₂) Free
- PFOS Free
- SVHC Free

Contact Information

For the latest specifications, additional product information, worldwide sales and distribution locations:

Tel: 1-844-890-8163

Web: www.qorvo.com

Email: customer.support@qorvo.com

For technical questions and application information: **Email:** appsupport@qorvo.com

Important Notice

The information contained herein is believed to be reliable; however, Qorvo makes no warranties regarding the information contained herein and assumes no responsibility or liability whatsoever for the use of the information contained herein. All information contained herein is subject to change without notice. Customers should obtain and verify the latest relevant information before placing orders for Qorvo products. The information contained herein or any use of such information does not grant, explicitly or implicitly, to any party any patent rights, licenses, or any other intellectual property rights, whether with regard to such information itself or anything described by such information. **THIS INFORMATION DOES NOT CONSTITUTE A WARRANTY WITH RESPECT TO THE PRODUCTS DESCRIBED HEREIN, AND QORVO HEREBY DISCLAIMS ANY AND ALL WARRANTIES WITH RESPECT TO SUCH PRODUCTS WHETHER EXPRESS OR IMPLIED BY LAW, COURSE OF DEALING, COURSE OF PERFORMANCE, USAGE OF TRADE OR OTHERWISE, INCLUDING THE IMPLIED WARRANTIES OF MERCHANTABILITY AND FITNESS FOR A PARTICULAR PURPOSE.**

Without limiting the generality of the foregoing, Qorvo products are not warranted or authorized for use as critical components in medical, life-saving, or life-sustaining applications, or other applications where a failure would reasonably be expected to cause severe personal injury or death.

Copyright 2018 © Qorvo, Inc. | Qorvo is a registered trademark of Qorvo, Inc.

X-ON Electronics

Largest Supplier of Electrical and Electronic Components

Click to view similar products for [RF Amplifier](#) category:

Click to view products by [Qorvo](#) manufacturer:

Other Similar products are found below :

[A82-1](#) [BGA622H6820XTSA1](#) [BGA 728L7 E6327](#) [BGB719N7ESDE6327XTMA1](#) [HMC397-SX](#) [HMC405](#) [HMC561-SX](#) [HMC8120-SX](#)
[HMC8121-SX](#) [HMC-ALH382-SX](#) [HMC-ALH476-SX](#) [SE2433T-R](#) [SMA3101-TL-E](#) [SMA39](#) [A66-1](#) [A66-3](#) [A67-1](#) [LX5535LQ](#) [LX5540LL](#)
[MAAM02350](#) [HMC3653LP3BETR](#) [HMC549MS8GETR](#) [HMC-ALH435-SX](#) [SMA101](#) [SMA32](#) [SMA411](#) [SMA531](#) [SST12LP17E-XX8E](#)
[SST12LP19E-QX6E](#) [WPM0510A](#) [HMC5929LS6TR](#) [HMC5879LS7TR](#) [HMC1126](#) [HMC1087F10](#) [HMC1086](#) [HMC1016](#) [SMA1212](#)
[MAX2689EWS+T](#) [MAAMSS0041TR](#) [MAAM37000-A1G](#) [LTC6430AIUF-15#PBF](#) [CHA5115-QDG](#) [SMA70-2](#) [SMA4011](#) [A231](#) [HMC-](#)
[AUH232](#) [LX5511LQ](#) [LX5511LQ-TR](#) [HMC7441-SX](#) [HMC-ALH310](#)