

### Product Description

Qorvo’s TGS2313 is a 4-18 GHz Single Pole Triple Throw (SP3T) Switch. This part is designed using Qorvo’s proven standard VPIN production process.

The TGS2313 provides a nominal 1.0 dB insertion loss, 12 dB return loss, and 35 dB isolation.

The TGS2313 integrated DC blocking capacitors on all ports and includes decoupled DC bias pads to reduce the number of off-chip components.

The part is ideally suited for EW receivers, radar, and communication systems.



### Block Diagram

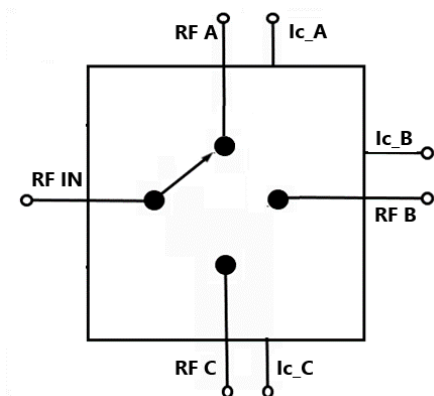

### Product Features

- Frequency Range: 4 - 18 GHz
- Insertion Loss: 1.0 dB
- Isolation: 35 dB Nominal
- Return Loss: 12dB Typical.
- On-Chip Bias Network
- DC Blocked at RF ports
- Die Dimensions: 2.06 x 2.03 x 0.10 mm

*Performance is typical across frequency. Please reference electrical specification table and data plots for more details.*

### Applications

- EW Receivers
- Radar
- Communications Systems

### Ordering Information

Part No.	Description
TGS2313	4 - 18 GHz High Isolation Switch



# TGS2313

## 4 – 18 GHz VPIN SP3T Switch

### Absolute Maximum Ratings

Parameter	Value
Positive Supply Voltage (V <sup>+</sup> )	+3 V
Negative Supply Voltage (V <sup>-</sup> )	-3 V
Positive Supply Current (I <sup>+</sup> )	22 mA
Power Dissipation, (P <sub>DISS</sub> ), CW, T = 25°C	0.45 W
RF Input Power, CW, 50 Ω, T = 25°C	24 dBm
Mounting Temperature (30 sec)	320 °C
Storage Temperature	-65 to 150

Operation of this device outside the parameter ranges given above may cause permanent damage. These are stress ratings only, and functional operation of the device at these conditions is not implied.

### Recommended Operating Conditions

Parameter	Min	Typ	Max	Units
Frequency	4		18	GHz
Input Power Handling (CW)		24		dBm
Control Current (I <sub>CONTROL</sub> )		±20		mA

Electrical specifications are measured at specified test conditions. Specifications are not guaranteed over all recommended operating conditions.

### Electrical Specifications

Test conditions unless otherwise noted: CW RF Input, Temp = +25 °C, Bias Conditions: I<sub>c</sub> = ±20 mA, See Function Table on page 4

Parameter	Conditions	Min	Typical	Max	Units
Operational Frequency Range		4		18	GHz
Insertion Loss	On-State		1.0		dB
Input Return Loss – Common Port RL	On-State		12		dB
Output Return Loss – Switched Port RL	On-State		12		dB
Isolation	Off-State		35		dB
Input Power			24		dBm

### Performance Plots –

Test conditions unless otherwise noted: CW RF Input, Temp= +25 °C, Bias Conditions: I<sub>CONTROL</sub> = ±20 mA

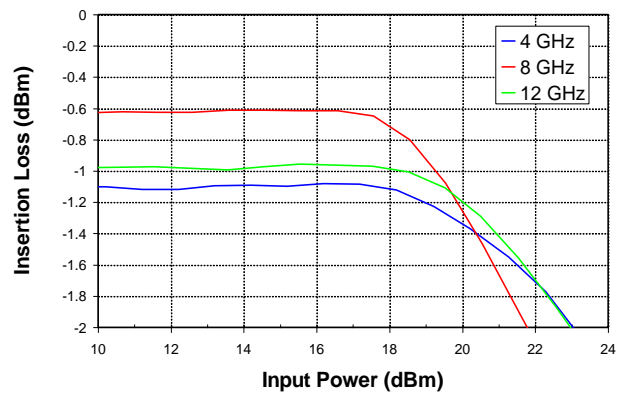
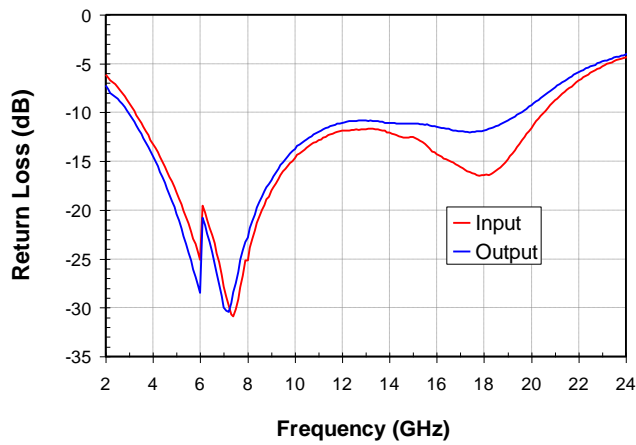
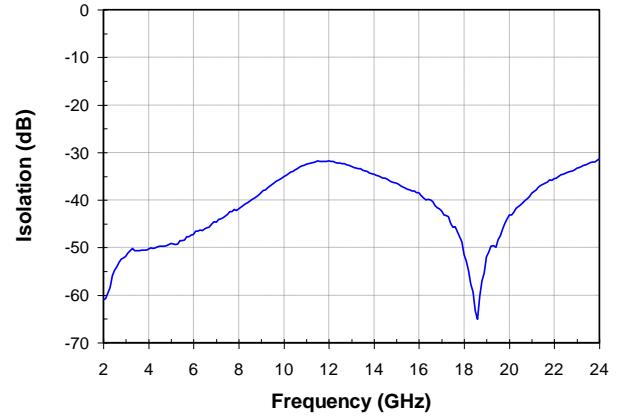
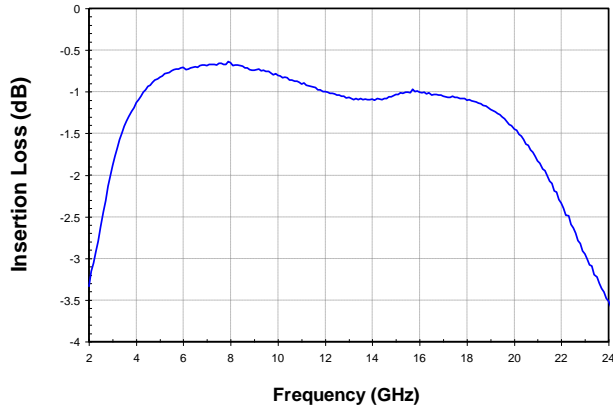

### Applications Circuit

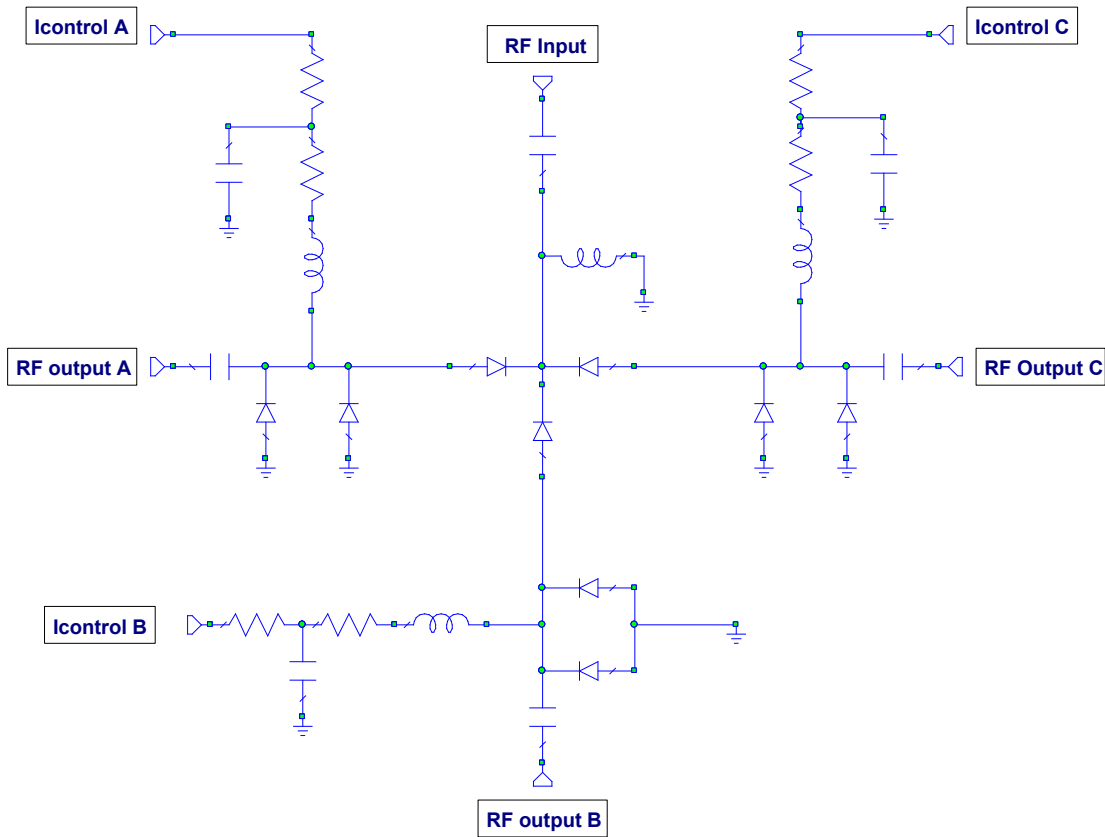

### Function Table

State	RF-A	RF-B	RF-C	I <sub>CONTROL A</sub>	I <sub>CONTROL B</sub>	I <sub>CONTROL C</sub>
1	Low-Loss	Isolated	Isolated	+20 mA	-20 mA	-20 mA
2	Isolated	Low-Loss	Isolated	-20 mA	+20 mA	-20 mA
3	Isolated	Isolated	Low-Loss	-20 mA	-20 mA	+20 mA

Notes: Typical DC voltage to achieve  $\pm 20$  mA at I<sub>CONTROL</sub> node is  $\pm 2.6$  -  $\pm 2.8$  V

## Assembly Drawing

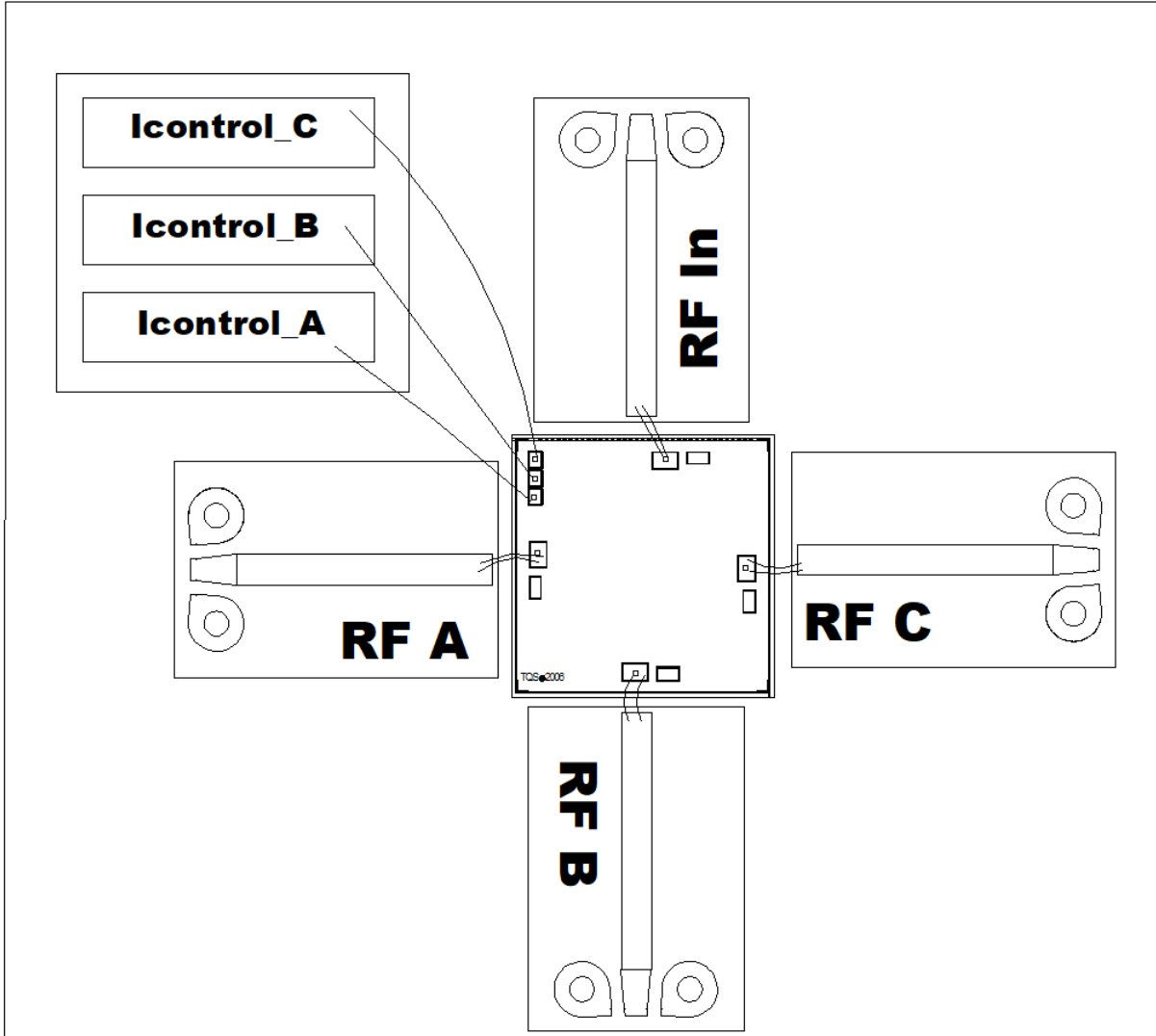

Note:

$\pm 20\text{mA}$  control lines (I<sub>CONTROL A</sub>, I<sub>CONTROL B</sub>, I<sub>CONTROL C</sub>) use on-chip resistors for diode current control.

**Mechanical Drawing and Bond Pad Description**

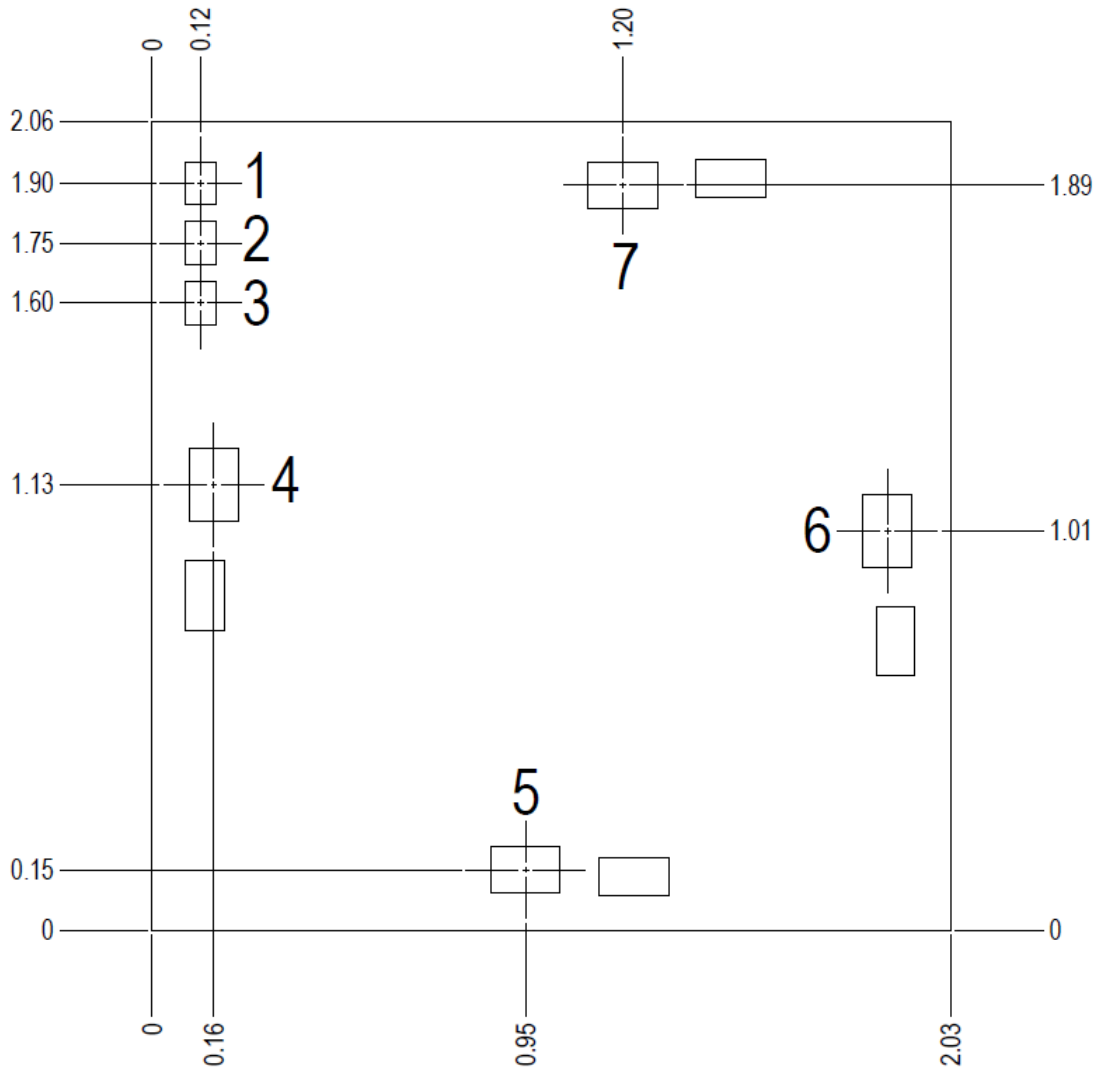

Pin No.	Symbol	Description	Pad Size (mm)
1	V <sub>C</sub>	Control voltage C	0.078 x 0.109
2	V <sub>B</sub>	Control voltage B	0.078 x 0.109
3	V <sub>A</sub>	Control voltage A	0.078 x 0.109
4	RF Output A	Output A, RF switched port A; matched to 50 Ω; DC coupled	0.127 x 0.185
5	RF Output B	Output B, RF switched port B; matched to 50 Ω; DC coupled	0.176 x 0.118
6	RF Output C	Output C, RF switched port C; matched to 50 Ω; DC coupled	0.125 x 0.185
7	RF Input	Input, RF common port; matched to 50 Ω; DC coupled	0.176 x 0.118

Thickness: 0.100 mm  
 Chip edge to bond pad dimensions is shown to center of bond pad  
 Chip size tolerance: ± 0.050 mm  
 GND is backside of MMIC

## Assembly Notes

---

Component placement and adhesive attachment assembly notes:

- Vacuum pencils and/or vacuum collets are the preferred method of pick up.
- Air bridges must be avoided during placement.
- The force impact is critical during auto placement.
- Organic attachment (i.e., conductive epoxy) can be used in low-power applications.
- Curing should be done in a convection oven; proper exhaust is a safety concern.

Reflow process assembly notes:

- Use AuSn (80/20) solder and limit exposure to temperatures above 300 °C to 3–4 minutes, maximum.
- An alloy station or conveyor furnace with reducing atmosphere should be used.
- Do not use any kind of flux.
- Coefficient of thermal expansion matching is critical for long-term reliability.
- Devices must be stored in a dry nitrogen atmosphere.

Interconnect process assembly notes:

- Thermosonic ball bonding is the preferred interconnect technique.
- Force, time, and ultrasonic are critical parameters.
- Aluminum wire should not be used.
- Devices with small pad sizes should be bonded with 0.0007-inch wire.

## Handling Precautions

Parameter	Rating	Standard		Caution! ESD-Sensitive Device
ESD – Human Body Model (HBM)	N/A	ESDA / JEDEC JS-001		

## Solderability

Use only AuSn (80/20) solder and limit exposure to temperatures above 300 °C to 3-4 minutes, maximum.

## RoHS Compliance

This product is compliant with the 2011/65/EU RoHS directive (Restrictions on the Use of Certain Hazardous Substances in Electrical and Electronic Equipment), as amended by Directive 2015/863/EU. This product also has the following attributes:

- Lead Free
- Halogen Free (Chlorine, Bromine)
- Antimony Free
- TBBP-A (C<sub>15</sub>H<sub>12</sub>Br<sub>4</sub>O<sub>2</sub>) Free
- PFOS Free
- SVHC Free

## Contact Information

For the latest specifications, additional product information, worldwide sales and distribution locations:

**Web:** [www.qorvo.com](http://www.qorvo.com)

**Tel:** 1-844-890-8163

**Email:** [customer.support@qorvo.com](mailto:customer.support@qorvo.com)

## Important Notice

The information contained herein is believed to be reliable; however, Qorvo makes no warranties regarding the information contained herein and assumes no responsibility or liability whatsoever for the use of the information contained herein. All information contained herein is subject to change without notice. Customers should obtain and verify the latest relevant information before placing orders for Qorvo products. The information contained herein or any use of such information does not grant, explicitly or implicitly, to any party any patent rights, licenses, or any other intellectual property rights, whether with regard to such information itself or anything described by such information. **THIS INFORMATION DOES NOT CONSTITUTE A WARRANTY WITH RESPECT TO THE PRODUCTS DESCRIBED HEREIN, AND QORVO HEREBY DISCLAIMS ANY AND ALL WARRANTIES WITH RESPECT TO SUCH PRODUCTS WHETHER EXPRESS OR IMPLIED BY LAW, COURSE OF DEALING, COURSE OF PERFORMANCE, USAGE OF TRADE OR OTHERWISE, INCLUDING THE IMPLIED WARRANTIES OF MERCHANTABILITY AND FITNESS FOR A PARTICULAR PURPOSE.**

Without limiting the generality of the foregoing, Qorvo products are not warranted or authorized for use as critical components in medical, life-saving, or life-sustaining applications, or other applications where a failure would reasonably be expected to cause severe personal injury or death.

Copyright 2021 © Qorvo, Inc. | Qorvo is a registered trademark of Qorvo, Inc.



## X-ON Electronics

Largest Supplier of Electrical and Electronic Components

*Click to view similar products for [RF Switch ICs](#) category:*

*Click to view products by [Qorvo](#) manufacturer:*

Other Similar products are found below :

[MASW-008853-TR3000](#) [BGS13SN8E6327XTSA1](#) [BGSX210MA18E6327XTSA1](#) [SKY13446-374LF](#) [SW-227-PIN](#) [CG2185X2](#) [CG2415M6](#)  
[MA4SW410B-1](#) [MASW-002102-13580G](#) [MASW-008543-001SMB](#) [MASW-008955-TR3000](#) [TGS4307](#) [BGS 12PL6 E6327](#)  
[BGS1414MN20E6327XTSA1](#) [BGS1515MN20E6327XTSA1](#) [BGSA11GN10E6327XTSA1](#) [BGSX28MA18E6327XTSA1](#) [HMC199AMS8](#)  
[HMC986A](#) [SKY13374-397LF](#) [SKY13453-385LF](#) [CG2430X1-C2](#) [CG2415M6-C2](#) [HMC986A-SX](#) [SW-314-PIN](#) [UPG2162T5N-E2-A](#)  
[SKY13416-485LF](#) [MASWSS0204TR-3000](#) [MASWSS0201TR](#) [MASWSS0181TR-3000](#) [MASW-007588-TR3000](#) [MASW-004103-13655P](#)  
[MASW-003102-13590G](#) [MASWSS0202TR-3000](#) [MA4SW310B-1](#) [MA4SW110](#) [SW-313-PIN](#) [CG2430X1](#) [SKY13321-360LF](#) [SKY13405-](#)  
[490LF](#) [BGSF 18DM20 E6327](#) [SKY13415-485LF](#) [MMS008PP3](#) [BGS13PN10E6327XTSA1](#) [SKY13319-374LF](#) [BGS14PN10E6327XTSA1](#)  
[SKY12213-478LF](#) [SKY13404-466LF](#) [MASW-011060-TR0500](#) [SKYA21024](#)