

77 GHz Transceiver Switch

TGS4307

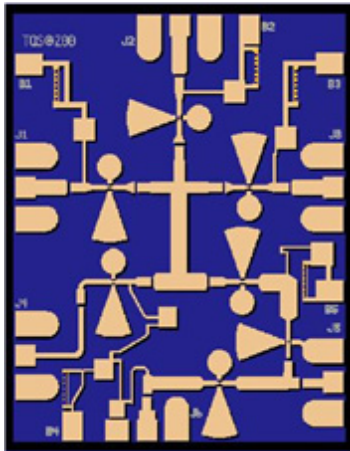

Key Features

- I/O Compatible with MA4GC6772
- 3 Antenna Ports
- Receive, Source, and LO Ports
- 2.5 dB RX/TX Insertion Loss Typical
- 40 dB Source/Mixer Isolation Typical
- 25 dB Ant/Ant Isolation Typical
- Bias Supply: 1.3V@40mA
- Die Size: 1.70 x 2.16 x 0.1 mm

Primary Applications

- Automotive Radar
- Instrumentation

Product Description

The TGS4307 is a 77 GHz switch matrix for use in automotive radar transceivers. The switch is designed using TriQuint's proven VPIN diode production process.

Three antenna ports may be selected independently and directed to a source (J5) or a receive (J4) port. Additionally, the source port can be directed to the LO port for use with a downconverting mixer.

Radar Application Schematic

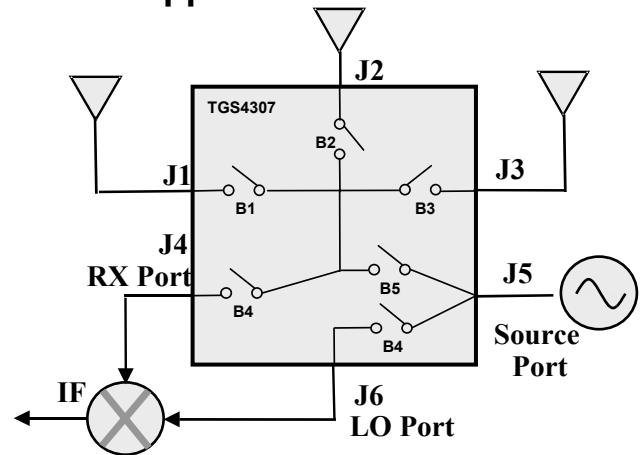

Measured Fixtured Data

Bias: 1.3V @ 40mA

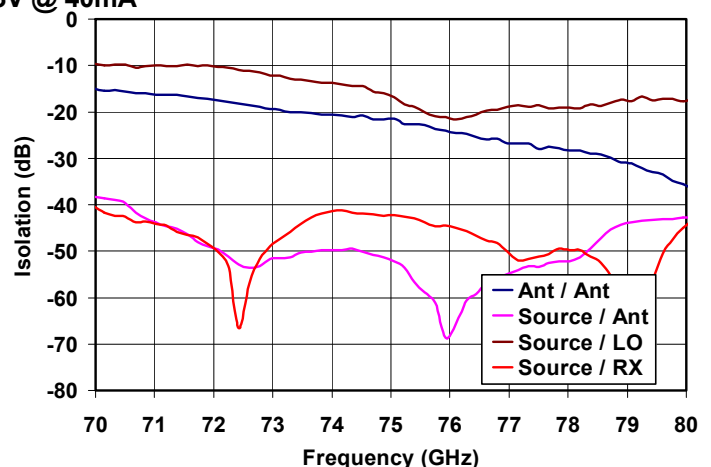
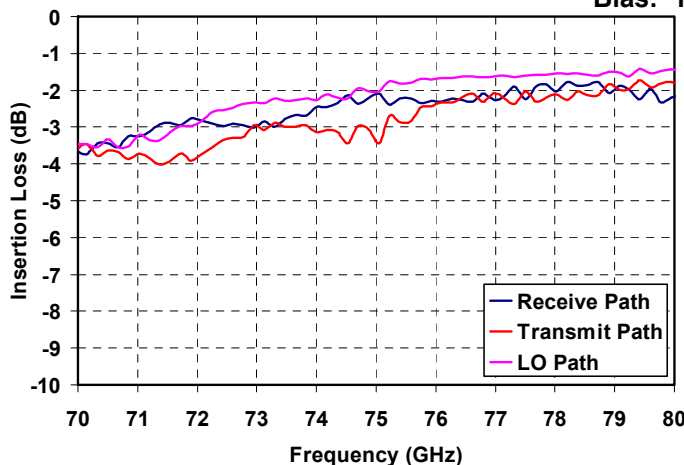

Note: Datasheet is subject to change without notice.

TABLE I
MAXIMUM RATINGS ^{1/}

| SYMBOL | PARAMETER | VALUE | NOTES |
|------------------|-------------------------------------|---------------|-----------------------|
| V ⁺ | Positive Supply Voltage | 2 V | <u>2/</u> |
| V ⁻ | Negative Supply Voltage | -8 V | <u>2/</u> |
| I ⁺ | Positive Supply Current (Quiescent) | 80 mA | <u>2/</u> , <u>3/</u> |
| P _{IN} | Input Continuous Wave Power | TBD | |
| P _D | Power Dissipation | 160 mW | <u>2/</u> |
| T _M | Mounting Temperature (30 Seconds) | 320 °C | |
| T _{STG} | Storage Temperature | -65 to 150 °C | |

- 1/ These ratings represent the maximum operable values for this device.
- 2/ Combinations of supply voltage, supply current, input power, and output power shall not exceed P_D.
- 3/ Control line B1, B2, B3 maximum current = 20 mA
Control line B4, B5 maximum current = 40 mA

TABLE II
ELECTRICAL CHARACTERISTICS
(Ta = 25 °C Nominal)

| PARAMETER | TYPICAL | UNITS |
|---|----------------|--------------|
| Frequency Range | 75 - 80 | GHz |
| Bias Supply | 1.3V @ 40mA | |
| Insertion Loss, Port J3 to J4 (RX) | 2.5 | dB |
| Insertion Loss, Port J1 to J5 (TX) | 2.5 | dB |
| Insertion Loss Source to LO, Port J5 to J6 (RX) | 1.8 | dB |
| Isolation Source to RX, Port J4 to J5 (RX) | >40 | dB |
| Isolation Source to Antenna, Port J1 to J5 (RX) | >40 | dB |
| Isolation Antenna to Antenna, Port J1 to J3 (RX,TX) | 25 | dB |
| Isolation Source to LO, Port J5 to J6 (TX) | 20 | dB |
| Return Loss | >8 | dB |

Preliminary Measured Data

Bias: 1.3V @ 40mA

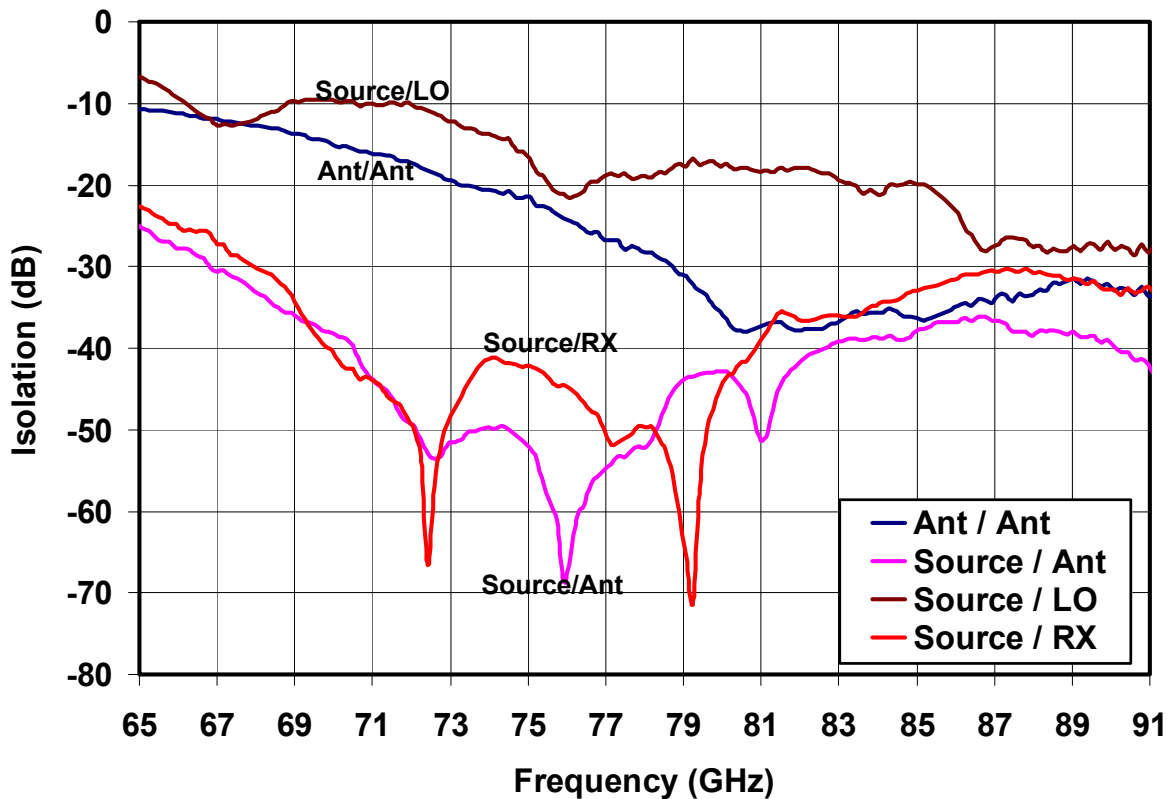
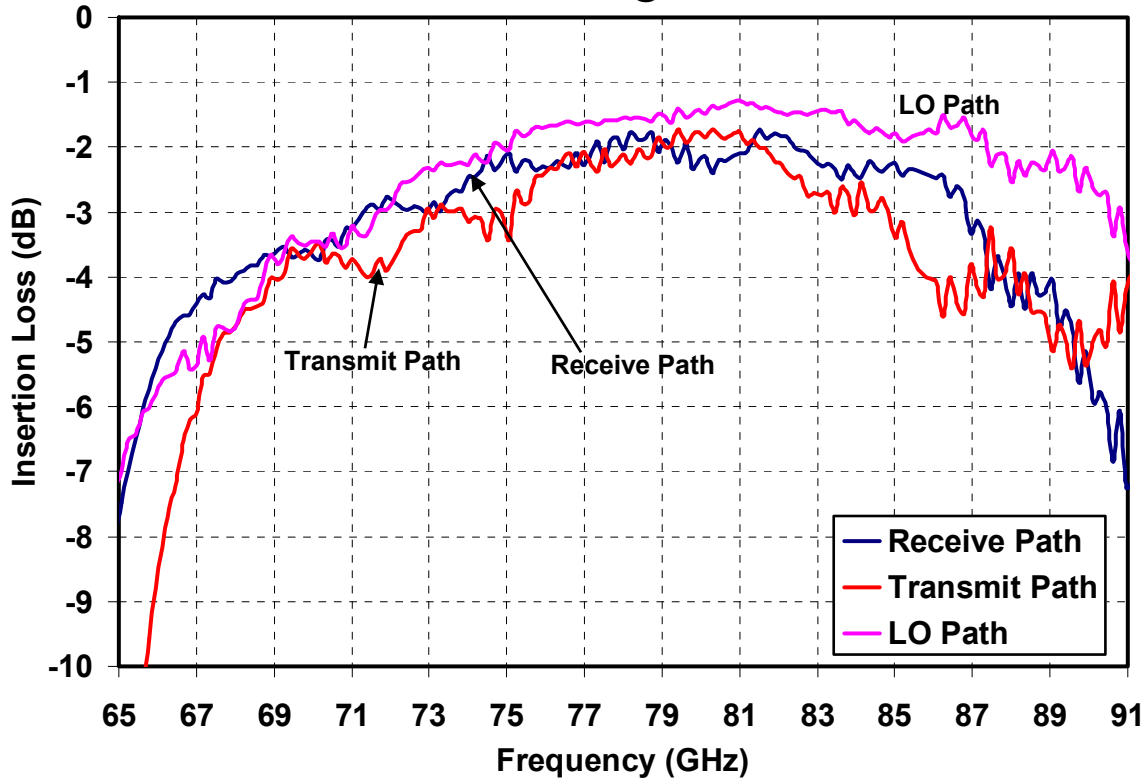

Preliminary Measured Data

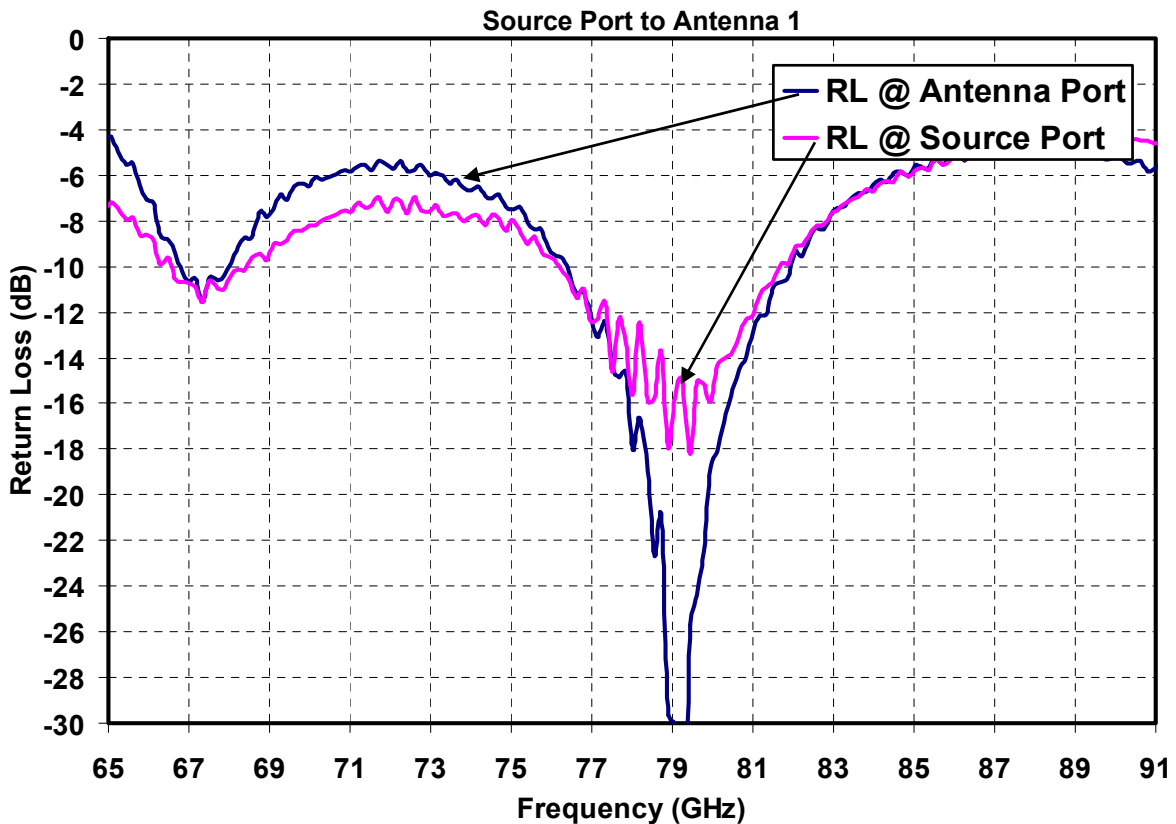
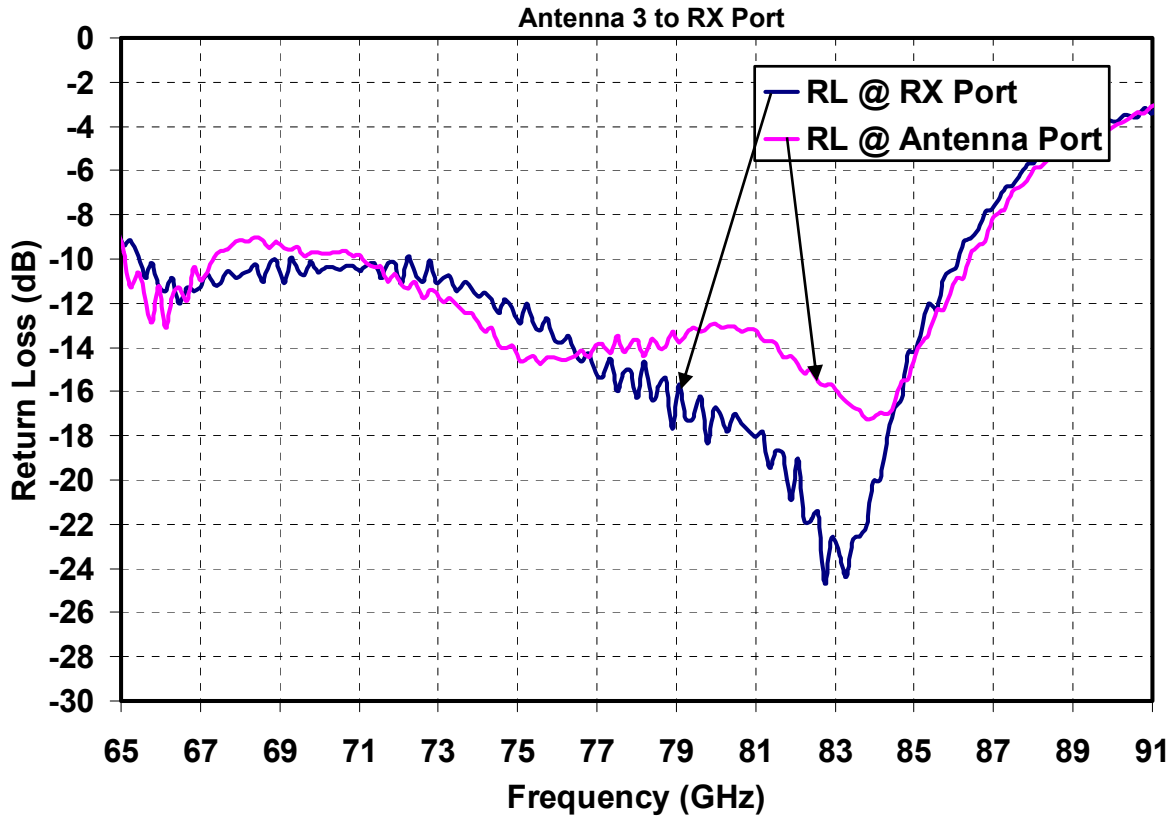

Preliminary Measured Data

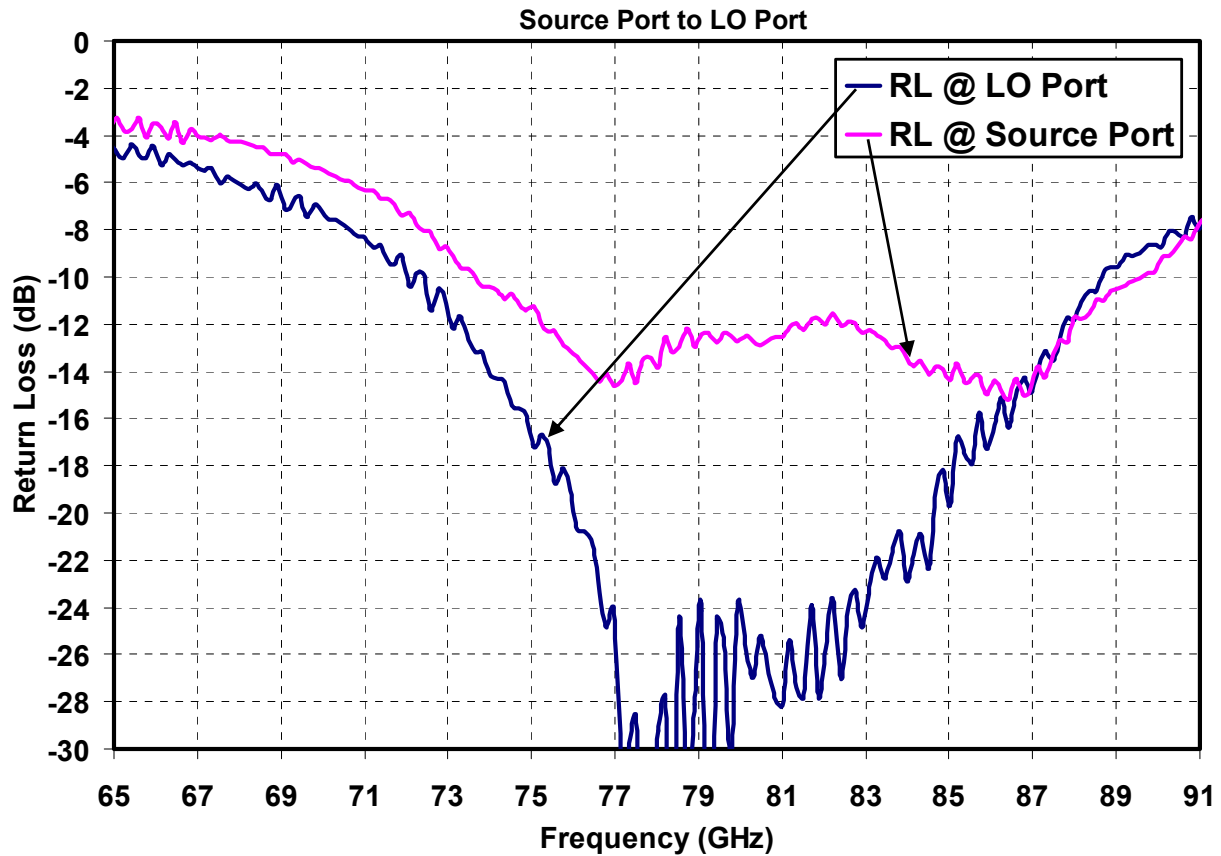

Mechanical Drawing

TGS4307

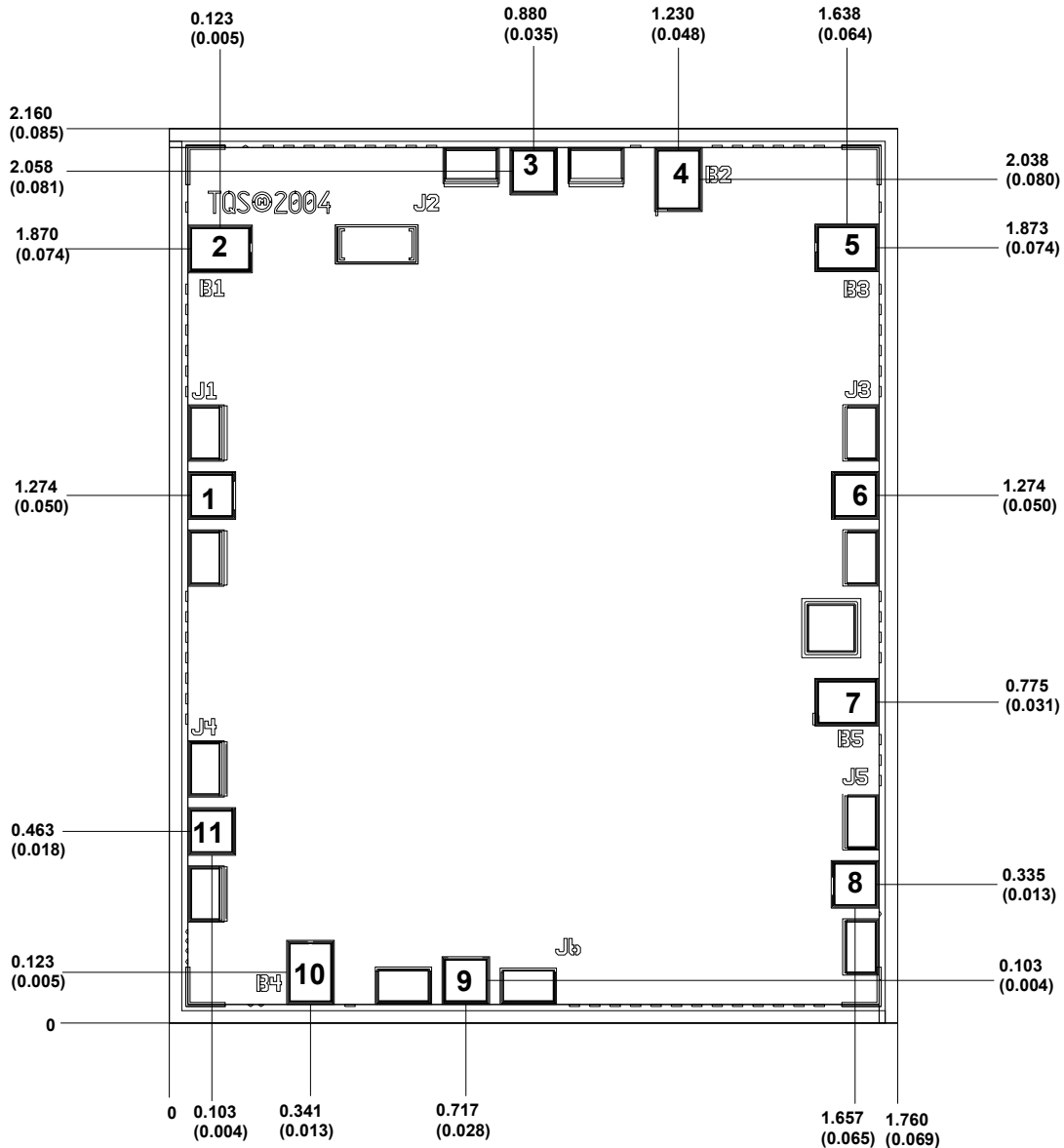

Units: millimeters (inches)
 Thickness: 0.1016 (0.004)
 Chip edge to bond pad dimensions are shown to center of bond pads
 Chip size tolerance: +/- 0.05 (0.002)
 GND IS BACKSIDE OF MMIC

| | |
|-------------------------------|-------------------------------|
| Bond Pad # 1 (Antenna Port 1) | 0.100 x 0.100 (0.004 x 0.004) |
| Bond Pad # 2 (VB1) | 0.140 x 0.100 (0.006 x 0.004) |
| Bond Pad # 3 (Antenna Port 2) | 0.100 x 0.100 (0.004 x 0.004) |
| Bond Pad # 4 (VB2) | 0.100 x 0.140 (0.004 x 0.006) |
| Bond Pad # 5 (VB3) | 0.140 x 0.100 (0.006 x 0.004) |
| Bond Pad # 6 (Antenna Port 3) | 0.100 x 0.100 (0.004 x 0.004) |
| Bond Pad # 7 (VB5) | 0.140 x 0.100 (0.006 x 0.004) |
| Bond Pad # 8 (Source Port) | 0.100 x 0.100 (0.004 x 0.004) |
| Bond Pad # 9 (LO Port) | 0.100 x 0.100 (0.004 x 0.004) |
| Bond Pad # 10 (VB4) | 0.100 x 0.140 (0.004 x 0.006) |
| Bond Pad # 11 (Receiver Port) | 0.100 x 0.100 (0.004 x 0.004) |

GaAs MMIC devices are susceptible to damage from Electrostatic Discharge. Proper precautions should be observed during handling, assembly and test.

Assembly Drawing

External Interface (TFN)

Substrate: Alumina
 $\epsilon_r=9.8$
 Thickness=5mil

Switch MMIC

Substrate: GaAs
 $\epsilon_r=12.9$
 Thickness=4mil

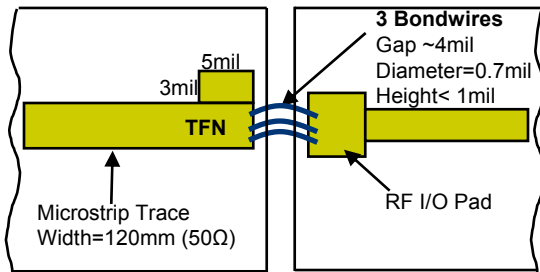

Note: Ribbon bond is acceptable (instead of 3 bondwires)

Recommended Interconnect Scheme

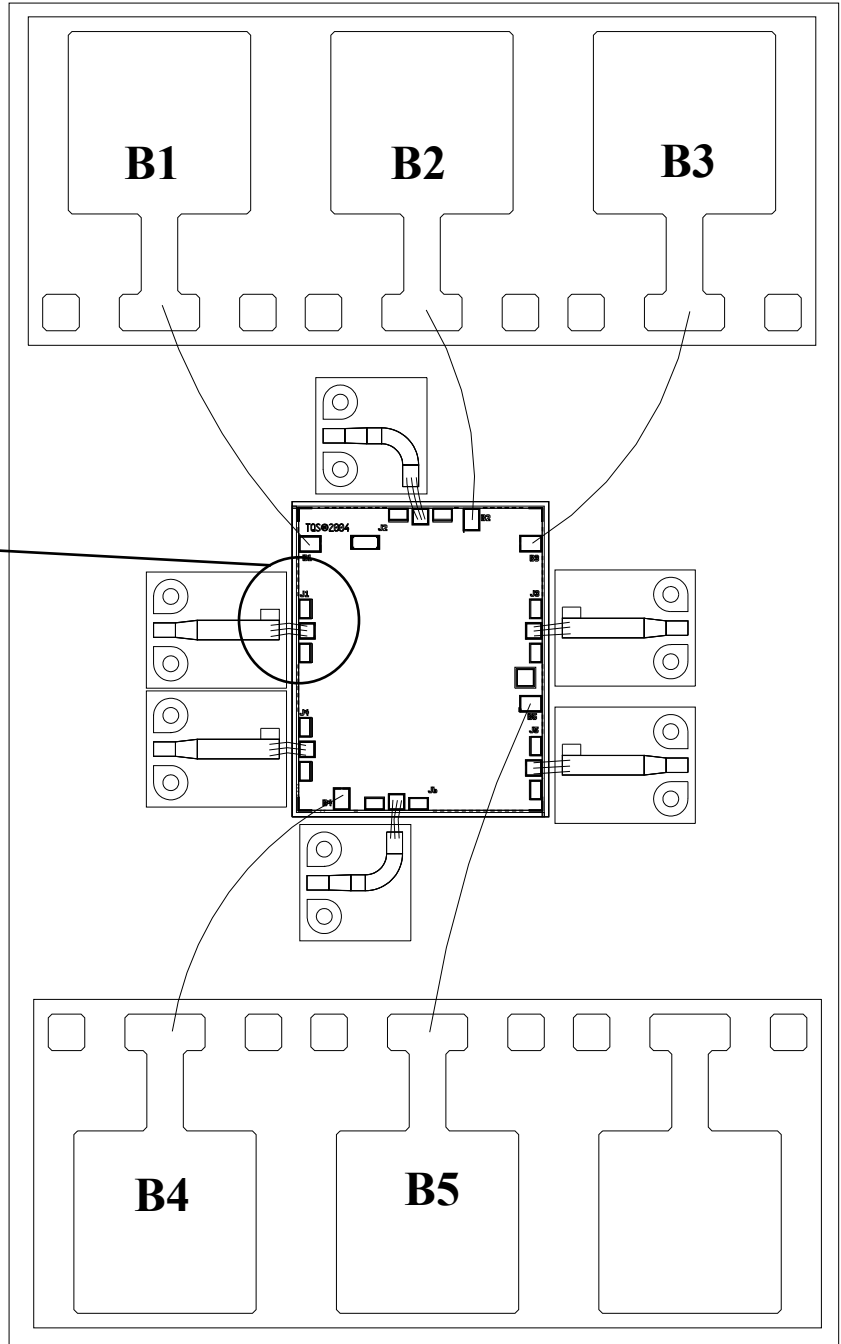

Note: Unused Ports should be terminated with 50 Ω.

GaAs MMIC devices are susceptible to damage from Electrostatic Discharge. Proper precautions should be observed during handling, assembly and test.

Application Schematic

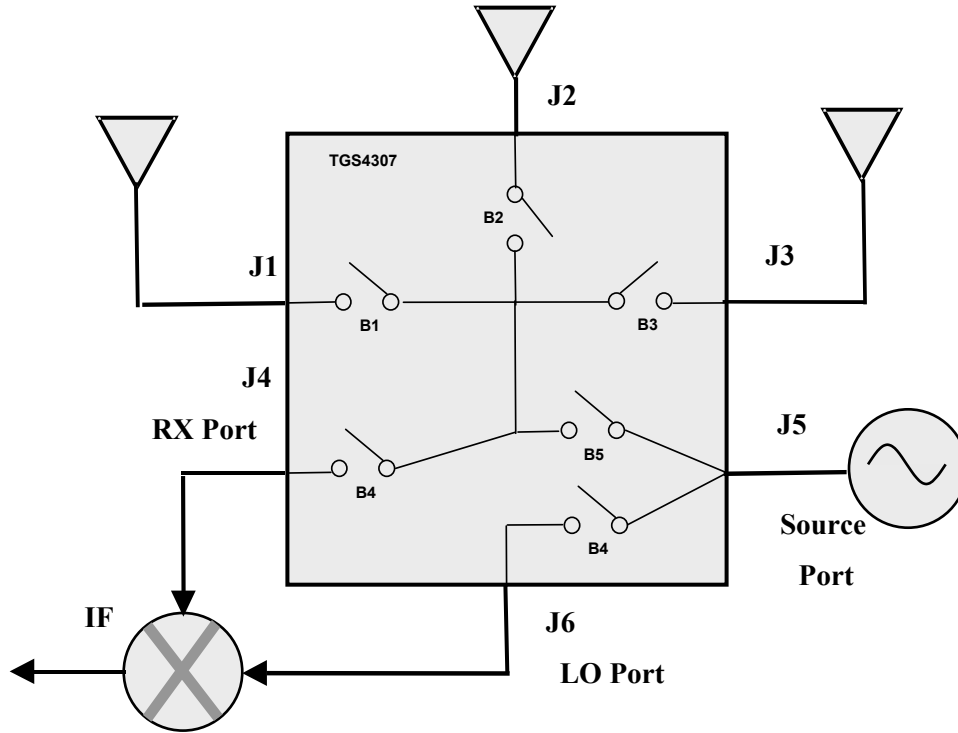

Bias State Table

| Function | Selected Antenna (B1, B2, or B3) | Unused Antennas (B1, B2, or B3) | B4 | B5 |
|----------|----------------------------------|---------------------------------|-------|-------|
| Transmit | -5 to 0V | +10mA each | +20mA | 0V |
| Receive | -5 to 0V | +10mA each | 0V | +20mA |

Forward voltage is ~ +1.3V to achieve bias current

GaAs MMIC devices are susceptible to damage from Electrostatic Discharge. Proper precautions should be observed during handling, assembly and test.

Assembly Process Notes

Reflow process assembly notes:

- Use AuSn (80/20) solder with limited exposure to temperatures at or above 300⁰C (30 seconds max).
- An alloy station or conveyor furnace with reducing atmosphere should be used.
- No fluxes should be utilized.
- Coefficient of thermal expansion matching is critical for long-term reliability.
- Devices must be stored in a dry nitrogen atmosphere.

Component placement and adhesive attachment assembly notes:

- Vacuum pencils and/or vacuum collets are the preferred method of pick up.
- Air bridges must be avoided during placement.
- The force impact is critical during auto placement.
- Organic attachment can be used in low-power applications.
- Curing should be done in a convection oven; proper exhaust is a safety concern.
- Microwave or radiant curing should not be used because of differential heating.
- Coefficient of thermal expansion matching is critical.

Interconnect process assembly notes:

- Wedge bonding is the preferred interconnect technique.
- Force, time, and ultrasonics are critical parameters.
- Aluminum wire should not be used.
- Maximum stage temperature is 200⁰C.

GaAs MMIC devices are susceptible to damage from Electrostatic Discharge. Proper precautions should be observed during handling, assembly and test.

X-ON Electronics

Largest Supplier of Electrical and Electronic Components

Click to view similar products for [RF Switch ICs](#) category:

Click to view products by [Qorvo](#) manufacturer:

Other Similar products are found below :

[MASW-008853-TR3000](#) [BGS13SN8E6327XTSA1](#) [BGSX210MA18E6327XTSA1](#) [SKY13446-374LF](#) [SW-227-PIN](#) [CG2185X2](#) [CG2415M6](#)
[MA4SW410B-1](#) [MASW-002102-13580G](#) [MASW-008543-001SMB](#) [MASW-008955-TR3000](#) [TGS4307](#) [BGS 12PL6 E6327](#)
[BGS1414MN20E6327XTSA1](#) [BGS1515MN20E6327XTSA1](#) [BGSA11GN10E6327XTSA1](#) [BGSX28MA18E6327XTSA1](#) [HMC199AMS8](#)
[HMC986A](#) [SKY13374-397LF](#) [SKY13453-385LF](#) [CG2430X1-C2](#) [CG2415M6-C2](#) [HMC986A-SX](#) [SW-314-PIN](#) [UPG2162T5N-E2-A](#)
[SKY13416-485LF](#) [MASWSS0204TR-3000](#) [MASWSS0201TR](#) [MASWSS0181TR-3000](#) [MASW-007588-TR3000](#) [MASW-004103-13655P](#)
[MASW-003102-13590G](#) [MASWSS0202TR-3000](#) [MA4SW310B-1](#) [MA4SW110](#) [SW-313-PIN](#) [CG2430X1](#) [SKY13321-360LF](#) [SKY13405-](#)
[490LF](#) [BGSF 18DM20 E6327](#) [SKY13415-485LF](#) [MMS008PP3](#) [BGS13PN10E6327XTSA1](#) [SKY13319-374LF](#) [BGS14PN10E6327XTSA1](#)
[SKY12213-478LF](#) [SKY13404-466LF](#) [MASW-011060-TR0500](#) [SKYA21024](#)