

### Applications

- Wireless Infrastructure
- LTE / WCDMA / CDMA / GSM
- General Purpose Wireless

### Product Features

- Integrates Amp + VVA + Amp functionality
- 700-2800 MHz
- 22 dB Gain @ 2.6 GHz
- 3.0 dB Noise Figure @ max gain setting
- +27.1 dBm P1dB
- +42.0 dBm OIP3
- +5V Supply Voltage
- 235 mA Quiescent Current
- MTTF > 1000 Years

### General Description

The TQC9074 is a high dynamic range analog controlled variable gain amplifier (VGA) which operates from 0.7 to 2.8 GHz. The VGA is able to achieve high performance with +42.0 dBm OIP3 and +27.1 dBm P1dB over a wide gain variation range while only consuming 235 mA current.

The TQC9074 integrates a high linearity, low noise amplifier for the first stage, followed by a broadband voltage variable attenuator, and then with a high performance 1/2W P1dB amplifier. The input and output of the various individual stages are accessible with external pins to allow for optimization of performance at any sub-band across the VGA's 0.7 to 2.8 GHz operating frequency range. The TQC9074 is packaged in a RoHS-compliant, compact 5x5mm surface-mount leadless package. Superior thermal design allows the product to have a minimum MTTF rating of 1000 years at a mounting temperature of +85° C.

The TQC9074 is targeted for use in wireless infrastructure where high linearity, medium power, and high efficiency are required.

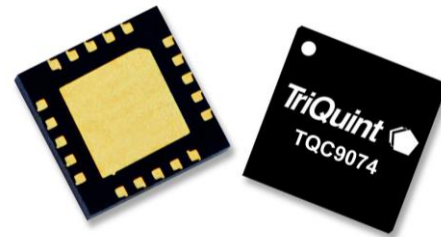

20-pin 5x5mm leadless SMT package

### Functional Block Diagram

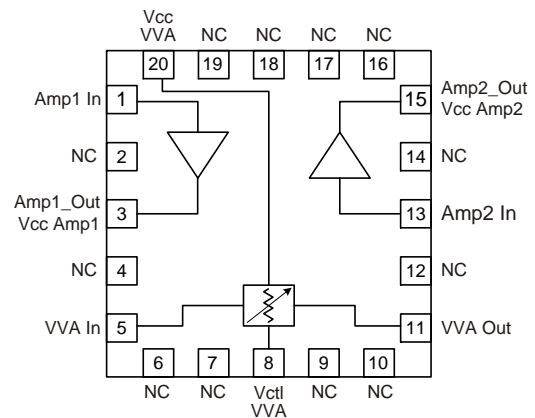

Pin No.	Label
1	Amp1_In
2, 4, 6, 7, 9, 10, 12, 14, 16, 17, 18, 19	NC (No Connect)
3	Amp1_Out / Vcc Amp1
5	VVA_In
8	Vctrl_VVA
11	VVA_Out
13	Amp2_In
15	Amp2_Out / Vcc Amp2
20	Vcc_VVA
Backside Paddle	RF/DC Ground

### Ordering Information

Part No.	Description
TQC9074	1/2W Variable Gain Amplifier
TQC9074-PCB2600	2600 MHz Evaluation Board

Standard T/R size = 2500 pcs on a 13" reel.

### Absolute Maximum Ratings

Parameter	Rating
Storage Temperature	-65 to 150 °C
RF Input Power, CW, 50Ω, 25°C	+10 dBm
V <sub>DD</sub> , Power Supply Voltage	+6 V

Operation of this device outside the parameter ranges given above may cause permanent damage.

### Recommended Operating Conditions

Parameter	Min	Typ	Max	Units
Supply Voltage (V <sub>DD</sub> )	+4.75	+5	+5.25	V
T <sub>ch</sub> (for >10 <sup>6</sup> hours MTTF)			+170	°C
Case Temperature	-40		+85	°C

Electrical specifications are measured at specified test conditions. Specifications are not guaranteed over all recommended operating conditions.

### Electrical Specifications

Test conditions: T<sub>LEAD</sub>=+25°C, V<sub>AMP</sub> = V<sub>DD</sub> =+5V

Parameter	Conditions	Min	Typ	Max	Units
Operational Frequency Range		700		2800	MHz
Test Frequency			2600		MHz
Gain	V <sub>ctrl</sub> = 0 V	20	22	24	dB
Gain	V <sub>ctrl</sub> = 4.021 V	3.7	6.7	9.7	dB
Gain Variation Range	See Note 1	25	30		dB
Input Return Loss			-14		dB
Output Return Loss			-10		dB
Output P1dB			+27.1		dBm
Output IP3	See Note 2		+41.5		dBm
ACLR	At P <sub>out</sub> = 12 dBm. See Note 3		-66		dBC
Noise Figure	At max gain level		3.0		dB
Voltage Control Range	0V = max gain level	0		5	V
Supply Voltage			+5		V
Amplifier Current (Pin 3 + 15)	See Notes 4 & 5	190	235	285	mA
VVA Current (Pin 8) @ minimum attenuation	See Note 6		3.6	6	mA
Thermal Resistance (R <sub>th</sub> )	Channel to case			40.3	°C /W

#### Notes:

- The gain variation range is measured as the difference in gain with V<sub>ctrl</sub> = 5 V and V<sub>ctrl</sub> = 0 V.
- OIP3 measured with two tones at an output power of +11 dBm / tone separated by 1 MHz. The suppression on the largest IM3 product is used to calculate the OIP3 using a 3:1 rule.
- 3GPP WCDMA, 1±64DPCH, 3.84 MHz BW, PAR=7.5 dB at 0.01% Probability, single carrier.
- Amp1 current (pin 3) is typically 85 mA.
- Amp2 current (pin 15) is typically 150 mA.
- VVA typical current is 3.6 mA for min attenuation and 1.6 mA for max attenuation.

## TQC9074-PCB2600 Evaluation Board

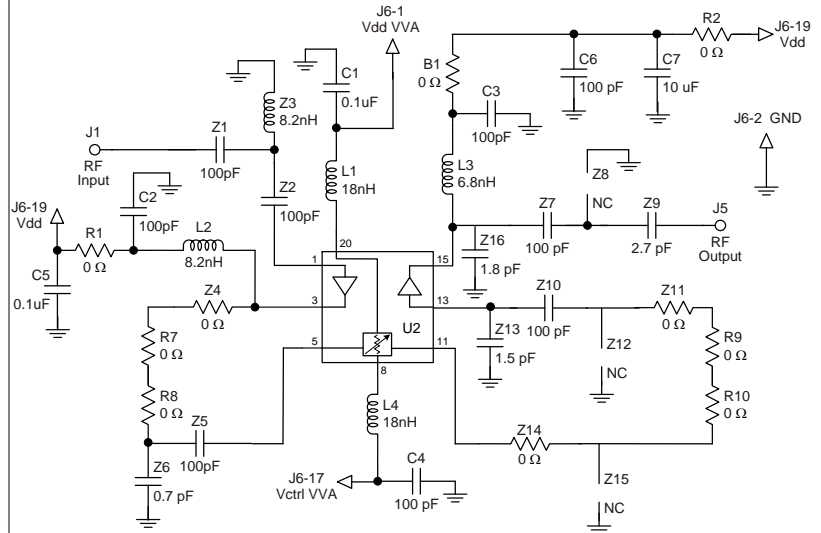
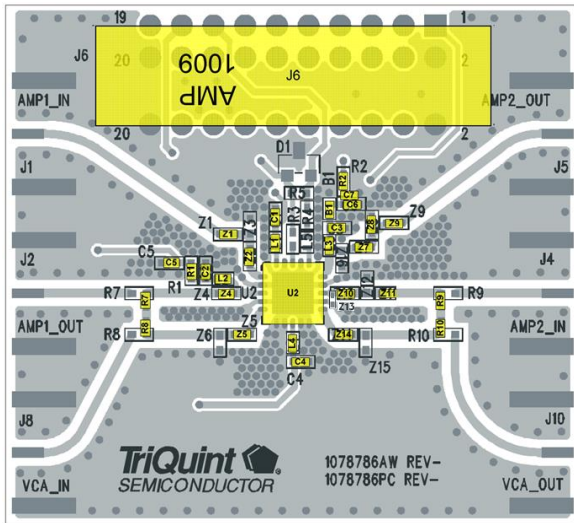

## Bill of Material – TQC9074-PCB2600

Reference Des.	Value	Description	Manuf.	Part No.
n/a	n/a	1078786PC Printed Circuit Board	TriQuint	N/A
U1	n/a	TQC9074 1/2 W Variable Gain Amplifier	TriQuint	TQC9074
L1, L4	18 nH	Ind., 0402, 5%, 420 mA, 3.1 GHz SRF	various	Various
L2, Z3	8.2 nH	Ind., 0402, 5%, 4.4 GHz SRF	various	various
L3	6.8 nH	Ind., 0402, 5%, 4.8 GHz SRF	various	various
B1, R1, R2, R7, R8, R9, R10, Z4, Z11, Z14	0 Ohm	Res., 0402, 5%, 1/16W	various	various
C7	10 uF	CAP, 6032, 20%, 50V, Tantalum	various	various
C1, C5	0.1 uF	Cap., 0402, 10%, 10V, X5R	various	various
C2, C3, C4, C6, Z1, Z2, Z5,	100 pF	Cap., 0402, 5%, 50V, NPO/COG	various	various
Z9	2.7 pF	Cap., 0402, +/-0.25PF. 50V. NPO/COG	various	various
Z16	1.8 pF	Cap., 0402, +/-0.25PF. 50V. NPO/COG	various	various
Z13	1.5 pF	Cap., 0402, +/- 0.1 pF, 25V, NPO/COG	various	various
Z6	0.7 pF	Cap., 0402, +/- 0.075PF. 25V. NPO/COG	various	various
J1, J5	n/a	Conn.062 RF SMA F STRT Flang	various	various
J6-1, J6-2, J6-17, J6-19	n/a	Conn, Header, 4 pin, right angle (Note 1)	various	various

### Typical Performance – TQC9074-PCB2600

Test conditions unless otherwise noted:  $V_{DD} = +5V$ ,  $I_{DD} = 235 \text{ mA (typ.)}$ ,  $V_{DD \text{ VVA}} = 0V$ ,  $Temp = +25^\circ C$

Parameter	Conditions	Typical Values			Units
Frequency		2500	2600	2700	MHz
Gain		22.4	22.1	21.8	dB
Input Return Loss		-17	-16	-16	dB
Output Return Loss		-13	-15	-17	dB
Output P1dB		+27.6	+27.5	+27.4	dBm
OIP3	$P_{out} = +10 \text{ dBm/tone}$ , $\Delta f = 1 \text{ MHz}$	+41.0	+41.5	+40.8	dBm
WCDMA Chan. Power <sup>(1)</sup>	-50 dBc ACLR	+16.7	+17.0	+16.5	dBm
Noise figure <sup>(2)</sup>		3.1	3.2	3.4	dB

Notes:

1. ACLR test set-up: 3GPP WCDMA, TM1+64 DPCH, +5 MHz offset, PAR = 10.2 dB at 0.01% Probability
2. Noise figure data shown in the table above is de-embedded from the eval board loss.

### Performance Plots – TQC9074-PCB\_RF

Test conditions unless otherwise noted:  $V_{DD} = +5V$ ,  $I_{DD} = 235 \text{ mA (typ.)}$ ,  $V_{DD \text{ VVA}} = 0V$ ,  $Temp = +25^\circ C$

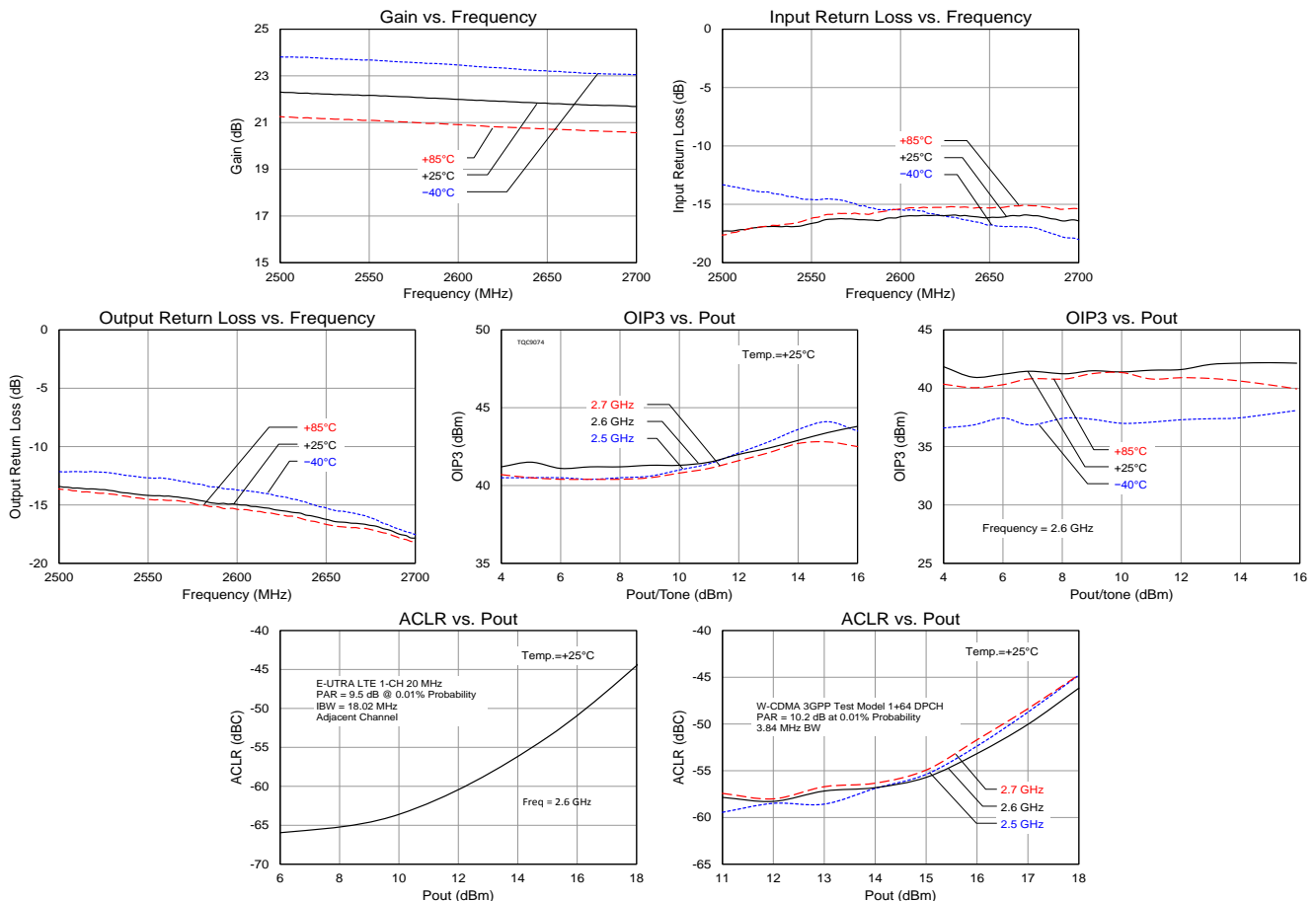

## Pin Configuration and Description

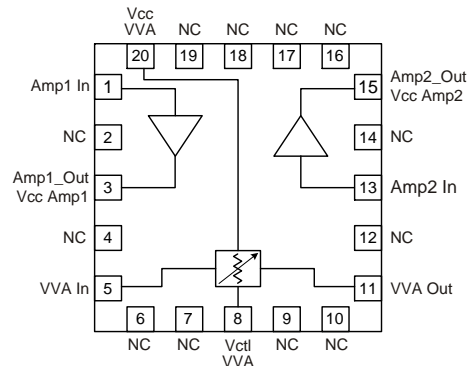

Pin No.	Label	Description
1	Amp1_In	RF input (Amp1). Band-specific matching circuit required.
2, 4, 6, 7, 9, 10, 12, 14, 16, 17, 18, 19	NC (No Connect)	No electrical connection. Land pads should be provided for PCB mounting integrity.
3	Amp1_Out/Vcc Amp1	RF output / DC supply (Amp1).
5	VVA_In	RF input (VVA).
8	Vctrl_VVA	Analog input for voltage controlled amplifier.
11	VVA_Out	RF output (VVA).
13	Amp2_In	RF input (Amp2). Band-specific matching circuit required.
15	Amp2_Out/Vcc Amp2	RF output / DC supply (Amp2). Band-specific matching circuit required.
20	Vcc_VVA	DC supply for voltage controlled amplifier.
Backside Paddle	RF/DC Ground	RF/DC ground. Provide recommended via pattern (see page 8) and ensure good solder attach for best thermal and electrical performance.



**Product Compliance Information****ESD Sensitivity Ratings**

Caution! ESD-Sensitive Device

ESD Rating: 1A  
Value: Passes  $\geq 250$  V to  $< 500$  V  
Test: Human Body Model (HBM)  
Standard: JEDEC Standard JS-001-2012

ESD Rating: C3  
Value: Passes  $\geq 1000$  V  
Test: Charged Device Model (CDM)  
Standard: JEDEC Standard JESD22-C101F

**MSL Rating**

MSL Rating: Level 3  
Test: +260 °C convection reflow  
Standard: JEDEC standard IPC/JEDEC J-STD-020

**Solderability**

Compatible with both lead-free (260 °C max. reflow temp.) and tin/lead (245 °C max. reflow temp.) soldering processes.

Package lead plating: Electrolytic plated Au over Ni.

**RoHS Compliance**

This part is compliant with EU 2002/95/EC RoHS directive (Restrictions on the Use of Certain Hazardous Substances in Electrical and Electronic Equipment).

This product also has the following attributes:

- Halogen Free (Chlorine, Bromine)
- Antimony Free
- TBBP-A (C<sub>15</sub>H<sub>12</sub>Br<sub>4</sub>O<sub>2</sub>) Free
- PFOS Free
- SVHC Free
- Lead Free

**Contact Information**

For the latest specifications, additional product information, worldwide sales and distribution locations, and information about TriQuint:

Web: [www.triquint.com](http://www.triquint.com)      Tel: +1.503.615.9000  
Email: [info-sales@triquint.com](mailto:info-sales@triquint.com)      Fax: +1.503.615.8902

For technical questions and application information:

Email: [sjapplications.engineering@triquint.com](mailto:sjapplications.engineering@triquint.com)

**Important Notice**

The information contained herein is believed to be reliable. TriQuint makes no warranties regarding the information contained herein. TriQuint assumes no responsibility or liability whatsoever for any of the information contained herein. TriQuint assumes no responsibility or liability whatsoever for the use of the information contained herein. The information contained herein is provided "AS IS, WHERE IS" and with all faults, and the entire risk associated with such information is entirely with the user. All information contained herein is subject to change without notice. Customers should obtain and verify the latest relevant information before placing orders for TriQuint products. The information contained herein or any use of such information does not grant, explicitly or implicitly, to any party any patent rights, licenses, or any other intellectual property rights, whether with regard to such information itself or anything described by such information.

TriQuint products are not warranted or authorized for use as critical components in medical, life-saving, or life-sustaining applications, or other applications where a failure would reasonably be expected to cause severe personal injury or death.

## X-ON Electronics

Largest Supplier of Electrical and Electronic Components

*Click to view similar products for [RF Amplifier](#) category:*

*Click to view products by [Qorvo](#) manufacturer:*

Other Similar products are found below :

[A82-1](#) [BGA622H6820XTSA1](#) [BGA 728L7 E6327](#) [BGB719N7ESDE6327XTMA1](#) [HMC397-SX](#) [HMC405](#) [HMC561-SX](#) [HMC8120-SX](#)  
[HMC8121-SX](#) [HMC-ALH382-SX](#) [HMC-ALH476-SX](#) [SE2433T-R](#) [SMA3101-TL-E](#) [SMA39](#) [A66-1](#) [A66-3](#) [A67-1](#) [LX5535LQ](#) [LX5540LL](#)  
[MAAM02350](#) [HMC3653LP3BETR](#) [HMC549MS8GETR](#) [HMC-ALH435-SX](#) [SMA101](#) [SMA32](#) [SMA411](#) [SMA531](#) [SST12LP17E-XX8E](#)  
[SST12LP19E-QX6E](#) [WPM0510A](#) [HMC5929LS6TR](#) [HMC5879LS7TR](#) [HMC1126](#) [HMC1087F10](#) [HMC1086](#) [HMC1016](#) [SMA1212](#)  
[MAX2689EWS+T](#) [MAAMSS0041TR](#) [MAAM37000-A1G](#) [LTC6430AIUF-15#PBF](#) [CHA5115-QDG](#) [SMA70-2](#) [SMA4011](#) [A231](#) [HMC-](#)  
[AUH232](#) [LX5511LQ](#) [LX5511LQ-TR](#) [HMC7441-SX](#) [HMC-ALH310](#)