

General Description

The TQC9305 is a digitally controlled variable gain amplifier (DVGA) with a broadband frequency range of 700 to 3600 MHz. The DVGA features high linearity and low noise while providing digital variable gain with a 31 dB of range in 1 dB steps through a serial mode control interface. At 1.9 GHz, the DVGA typically provides 13 dB gain, +40 dBm OIP3, +23 dBm P1dB and 3.1 dB noise figure. This combination of performance parameters makes the DVGA ideal for receiver applications requiring gain control with high IIP3 and low noise figure. In addition, the DVGA integrates a shut-down biasing capability to allow for easy operation for TDD applications.

The TQC9305 integrates a high performance digital step attenuator followed by a high linearity, broadband gain block. Both stages are internally matched to 50 Ohms and do not require any external matching components. The TQC9305 is packaged in a RoHS-compliant, compact 5x5 mm surface-mount leadless package.

Functional Block Diagram

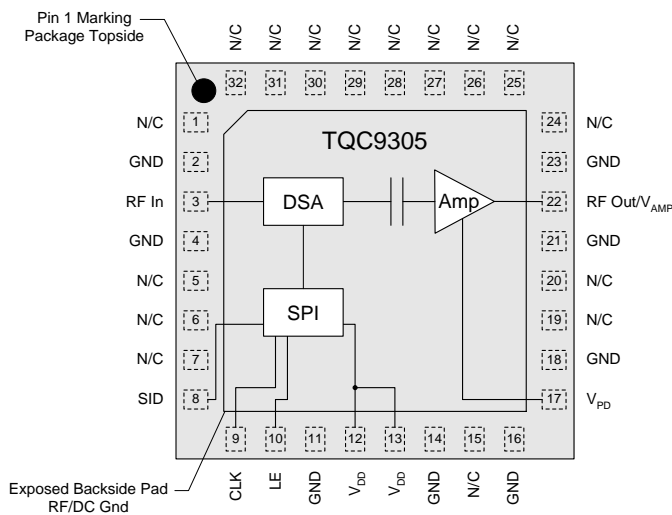

Top View

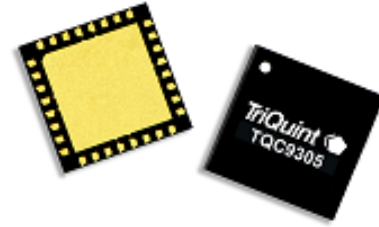

32 Pin 5X5 mm Leadless SMT Package

Product Features

- Integrates DSA + Amp Functionality
- 0.7 – 3.6 GHz Broadband Performance
- 5-bit control, 31 dB range
- 13 dB Gain at 1.9 GHz
- 3.1 dB Noise Figure at max gain setting
- +23 dBm P1dB
- +27 dBm IIP3, +40 dBm OIP3
- Integrated on-chip matching, 50 ohm in/out
- Integrated shutdown control for TDD compatibility
- +5V Supply Voltage
- CMOS SPI™ serial control interface, TTL logic compatible

Applications

- Wireless Infrastructure
- LTE / WCDMA / CDMA / GSM
- TDD or FDD systems
- General Purpose Wireless

Ordering Information

Part No.	Description
TQC9305TR13*	0.7-3.6 GHz DVGA
TQC9305-PCB	Evaluation Board

*Standard T/R size = 2500 pieces on a 13" reel

Absolute Maximum Ratings

Parameter	Rating
Storage Temperature	-65 to 150 °C
RF Input Power, CW, 50Ω, 24 hr, 25°C	+22 dBm
V _{DD} , Power Supply Voltage	-0.3 to +5.5 V
Digital Input Voltage	-0.3 to V _{DD} +0.5 V

Operation of this device outside the parameter ranges given above may cause permanent damage.

Recommended Operating Conditions

Parameter	Min	Typ	Max	Units
V _{AMP}	+4.75	+5	+5.25	V
V _{DD}	+3		+5	V
T _{ch} (for >10 ⁶ hours MTTF)			+190	°C
Case Temperature	-40		+105	°C

Electrical specifications are measured at specified test conditions. Specifications are not guaranteed over all recommended operating conditions.

Electrical Specifications

Test conditions unless otherwise noted: V_{DD} =+5V, Temp=+25°C, 50 Ω system.

Parameter	Conditions	Min	Typ	Max	Units
Operational Frequency Range		700		3600	MHz
Test Frequency			1950		MHz
Gain	Max gain setting	11.5	13	14.5	dB
Gain Control Range			31		dB
Gain Control Step Size			1		dB
Gain Accuracy	700 – 2700 MHz (major states)	± (0.3 + 4% of Atten. Setting)			dB
Input Return Loss			19		dB
Output Return Loss			16.5		dB
Output P1dB			+23		dBm
Output IP3	P _{out} /tone = 0 dBm, Δf = 1 MHz		+39.7		dBm
Input IP3	Pin/tone = -13 dBm, Δf = 1 MHz	+23.5	+26.7		dBm
Noise Figure	Max gain setting		3.1		dB
Switching Speed	OFF to ON State (50% V _{PD} to 90% RF _{out})		0.85		μs
	ON to OFF State (50% V _{PD} to 10% RF _{out})		2.0		μs
Amplifier Shutdown Control, V _{PD}	On state	0		0.4	V
	Off state (Power down)	1.5		V _{DD}	V
Shutdown pin current, I _{PD}	Off state		140		μA
Amplifier Current, I _{AMP} (pin 22)	On state	100	130	160	mA
	Off state (Power down)		3		mA
DSA Current, I _{DD} (pins 12, 13)			1.4		mA
Thermal Resistance (R _{th})	Channel to case		48.3		°C /W

Serial Control Interface

The TQC9305 has a CMOS SPI™ input compatible serial interface. This serial control interface converts the serial data input stream to parallel output word. The input is 3-wire (CLK, LE and SID) SPI™ input compatible. At power up, the serial control interface resets the DVGA to the minimum gain state (maximum attenuation setting). The 8-bit Serial Input Data (SID) word is loaded into the register on rising edge of the CLK, LSB first. When LE is high, CLK is internally disabled in the DVGA.

Serial Control Timing Characteristics (Test conditions: $V_{DD} = +5\text{ V}$, Temp.=25°C)

Parameter	Condition	Min	Max	Units
Clock Frequency	50% Duty Cycle		20	MHz
LE Setup Time, t_{LESUP}	after last CLK rising edge	10		ns
LE Pulse Width, t_{LEPW}		16		ns
SID set-up time, t_{SDSUP}	before CLK rising edge	8		ns
SID hold-time, t_{SDHLD}	after CLK rising edge	8		ns
Propagation Delay, t_{PLO}	LE to Parallel output valid	10		ns
LE pulse spacing, t_{LE}	LE to LE pulse spacing	630		ns

Serial Control DC Logic Characteristics (Test conditions: $V_{DD} = +5\text{ V}$, Temp.=25°C)

Parameter	Condition	Min	Max	Units
Low State Input Voltage, V_{IL}		0	0.8	V
High State Input Voltage, V_{IH}		2.1	V_{DD}	V
Input Current, I_{IH} / I_{IL}	On SID, LE and CLK	-10	+10	μA

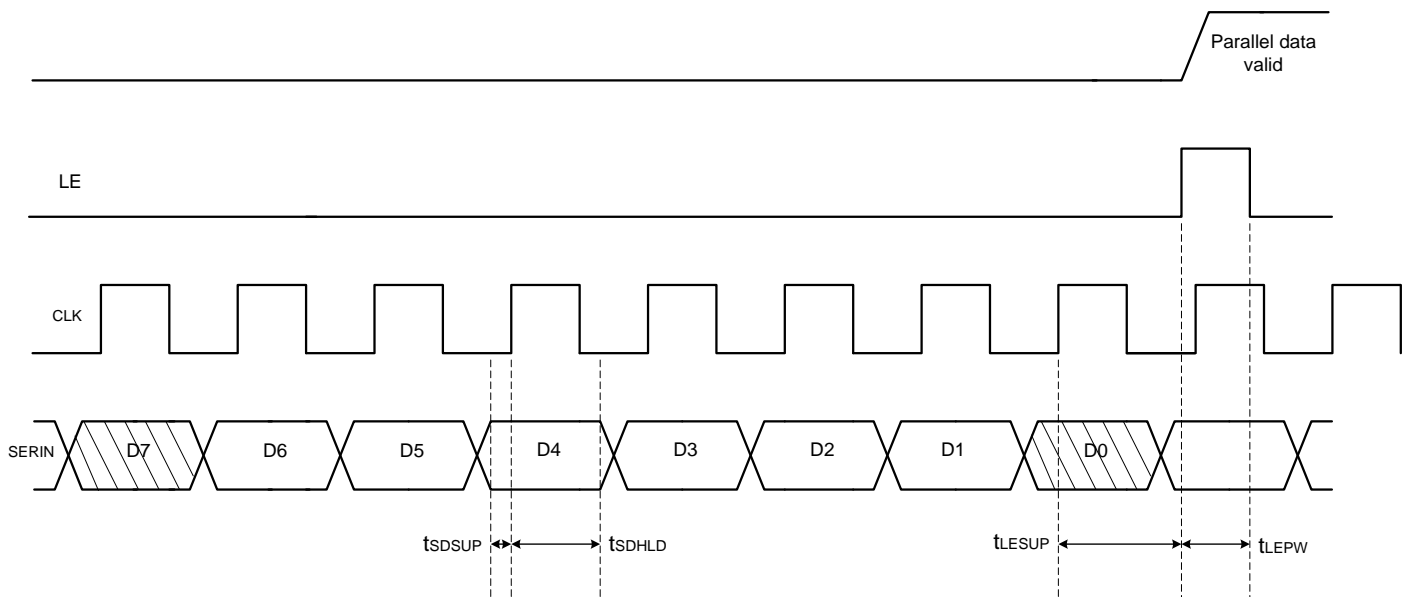

Serial Control Interface

Serial In Control Logic Truth Table, LSB in first

8-Bit Control Word								Attenuation
D7	D6	D5	D4	D3	D2	D1	D0	
0	0	0	0	0	0	0	0	Insertion loss
0	0	0	0	0	1	0	0	1 dB
0	0	0	0	1	0	0	0	2 dB
0	0	0	1	0	0	0	0	4 dB
0	0	1	0	0	0	0	0	8 dB
0	1	0	0	0	0	0	0	16 dB
0	1	1	1	1	1	0	0	31 dB
0	1	0	1	1	0	0	0	22 dB (example)

Note:

- 1) Bit D1 needs to be kept logic '0' to maintain the 1dB step for the DSA control.
- 2) Optionally, the DVGA can be used with a 0.5dB step attenuation by activating bit D1 and hence using 6-Bits (D1-D6).
- 3) Bits D0 and D7 are 'don't care'.

Performance Summary

Test conditions: $T_{LEAD}=+25^{\circ}\text{C}$, $V_{AMP} = V_{DD} = +5\text{V}$, $I_{AMP} = 130\text{ mA}$

Frequency	900	1700	1950	2140	2600	MHz
Gain	15	13.4	12.9	12.7	12	dB
Input Return Loss	18	18	19	20	18	dB
Output Return Loss	20	17	17	17	17	dB
Output P1dB	+23	+23	+23	+23	+22.1	dBm
Output IP3 (Pout/tone=0dBm, $\Delta f=1\text{MHz}$)	+41.2	+40	+40	+40	+38	dBm
Input IP3 (Pin/tone=-13dBm, $\Delta f=1\text{MHz}$)	+26.2	+26.5	+26.7	+27.5	+26	dBm
Noise Figure	2.8	3.0	3.1	3.2	3.6	dB
Amplifier Current, I_{AMP}	130					mA

Performance Plots

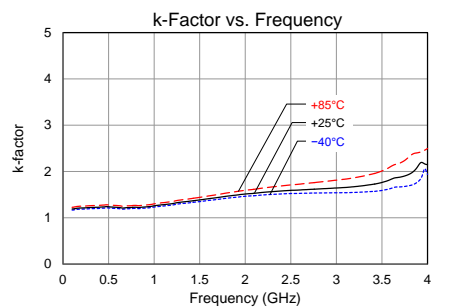
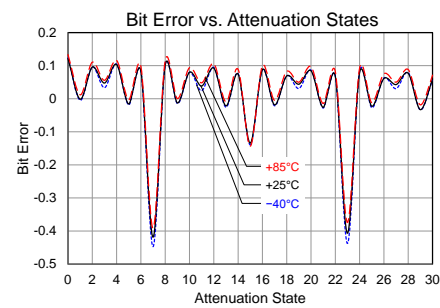
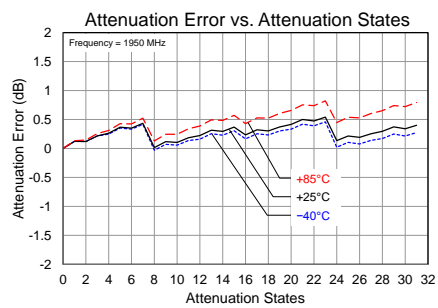
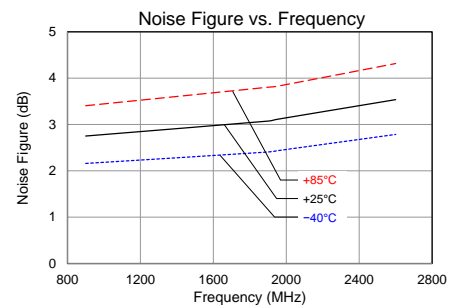
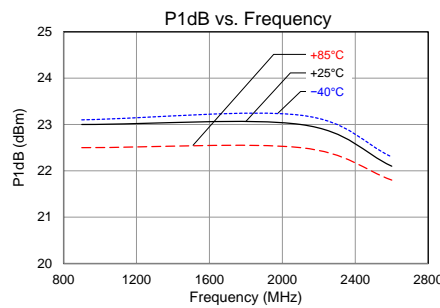
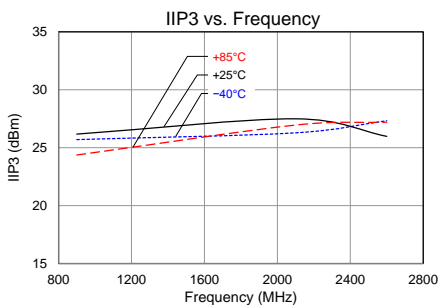
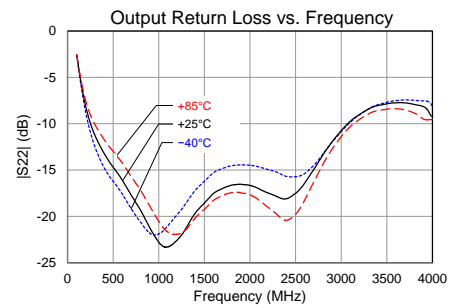
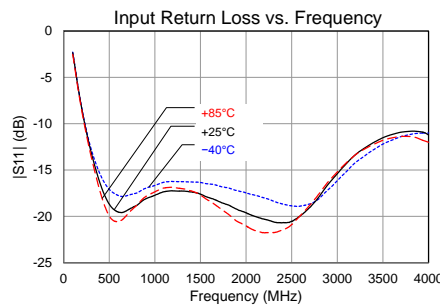
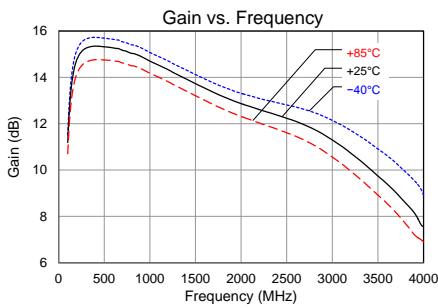

TQC9305-PCB Evaluation Board

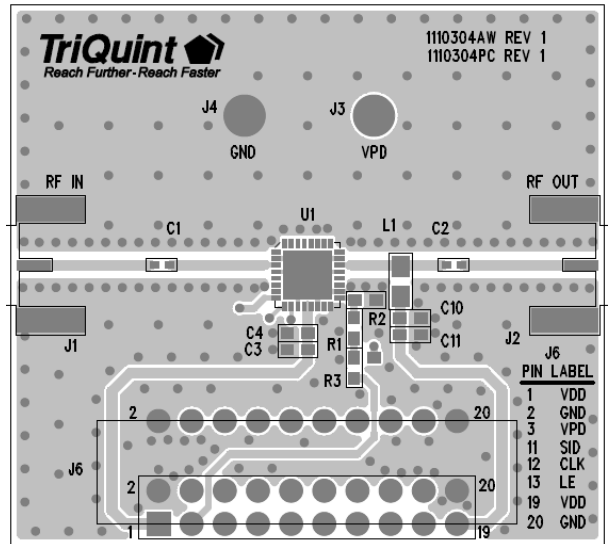
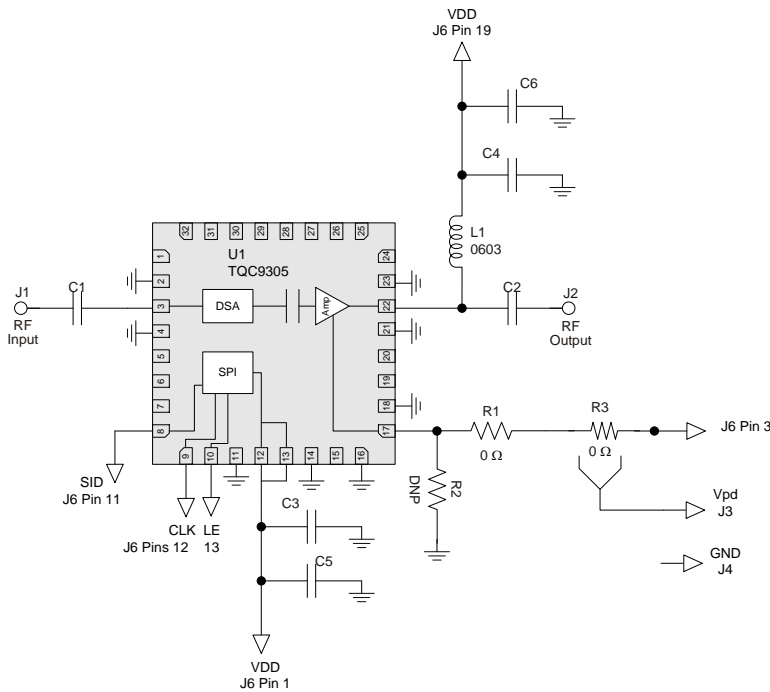

Note: R1, R2 & R3 need not be populated if the shut-down functionality is not required. Pin 17 can be left open or grounded.

Bill of Material: TQC9305-PCB

Reference Desg.	Value	Description	Manufacturer	Part Number
U1	n/a	TQC9305	Qorvo	TQC9305
C1, C2	33 pF	Cap, chip, 0402, 10%, 50V	Various	
C3, C4	100pF	Cap, chip, 0402, 10%, 50V	Various	
C5, C6	1.0uF	Cap, chip, 0603, 10%, 10V	Various	
L1	68nH	Ind, coil, 5%, 0603	Coilcraft	0603CS-68NXJL
R1, R3	0 Ω	Res, chip, 0603, 5%, 1/16W	Various	

Pin Configuration and Description

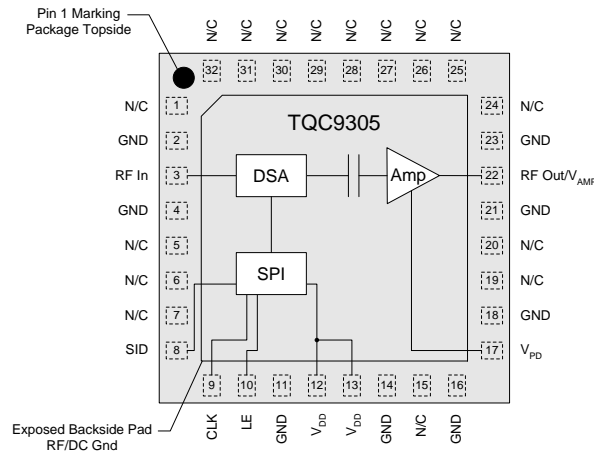

Pin No.	Label	Description
1, 5, 6, 7, 15, 19, 20, 24-32	N/C	No internal connection but can be grounded
2, 4, 11, 14, 16, 18, 21, 23	GND	DC/RF ground connection
3	RF In	RF input. Needs to be capacitively coupled
8	SID	Serial data input
9	CLK	Clock signal in
10	LE	Latch Enable pin
12, 13	V _{DD}	DC Supply Voltage for SPI and DSA. Pins are internally tied together
17	V _{PD}	Amplifier power down control pin
22	RF Out / V _{AMP}	RF output and DC bias for amplifier. Needs to be capacitively coupled
Backside Pad	RF/DC Ground	Ground connection for proper thermal dissipation

Evaluation Board Material Information

Qorvo PCB 1110304 Material and Stack-up

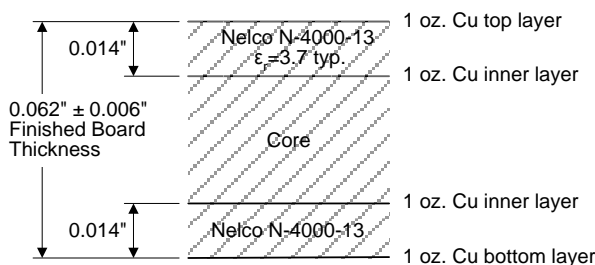

50 ohm line dimensions: width = .026", spacing = .032".

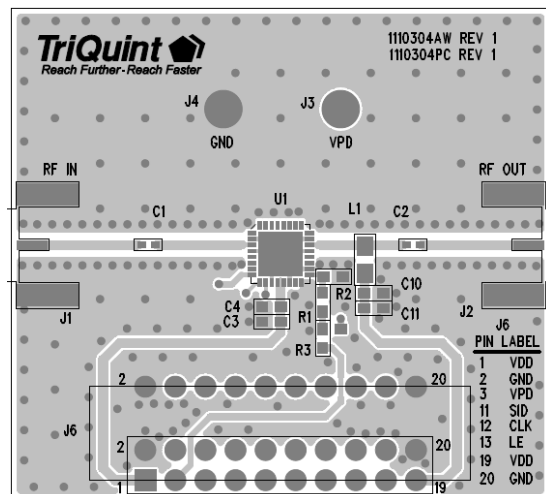

Package Marking and Dimensions

Package Marking:

Part number – TQC9305
 Year, week - YYWW
 Country code - CCCC
 Trace code – up to 6 characters

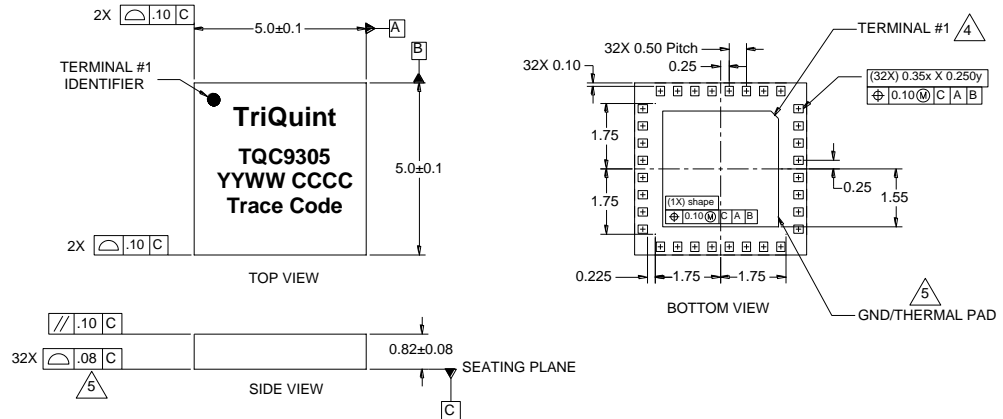

Notes:

1. All dimensions are in millimeters. Angles are in degrees.
2. Except where noted, this part outline conforms to JEDEC standard MO-270, Issue B (Variation DAE) for extra thin profile, fine pitch, internal stacking module (ISM).
3. Dimension and tolerance formats conform to ASME Y14.4M-1994.
4. The terminal #1 identifier and terminal numbering conform to JESD 95-1 SPP-012.
5. Co-planarity applies to the exposed ground/thermal pad as well as the contact pins.

PCB Mounting Pattern

All dimensions are in millimeters (inches). Angles are in degrees.

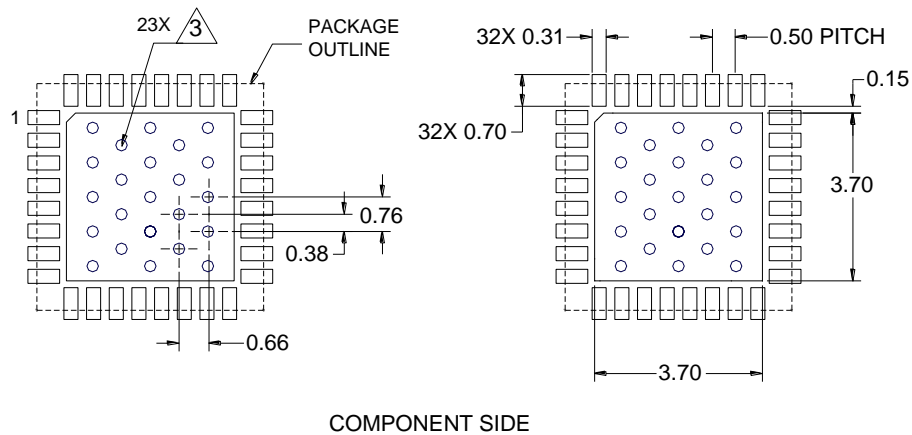

Notes:

1. All dimensions are in millimeters. Angles are in degrees.
2. Use 1 oz. copper minimum for top and bottom layer metal.
3. Vias are required under the backside paddle of this device for proper RF/DC grounding and thermal dissipation. We recommend a 0.35mm ($\#80/.0135''$) diameter bit for drilling via holes and a final plated thru diameter of 0.25mm ($0.10''$).
4. Ensure good package backside paddle solder attach for reliable operation and best electrical performance.

Handling Precautions

Parameter	Rating	Standard
ESD – Human Body Model (HBM)	Class 1A	ESDA / JEDEC JS-001-2014
ESD – Charged Device Model (CDM)	Class C3	ESDA / JEDEC JS-002-2014
MSL – Moisture Sensitivity Level	Level 3	IPC/JEDEC J-STD-020



Caution!
ESD-Sensitive Device

Solderability

Compatible with lead-free (260°C max. reflow temp.) soldering process.
Solder profiles available upon request.

Contact plating: Electrolytic plated Au over Ni

RoHS Compliance

This part is compliant with 2011/65/EU RoHS directive (Restrictions on the Use of Certain Hazardous Substances in Electrical and Electronic Equipment) as amended by Directive 2015/863/EU.

This product also has the following attributes:

- Lead Free
- Halogen Free (Chlorine, Bromine)
- Antimony Free
- TBBP-A (C₁₅H₁₂Br₄O₂) Free
- PFOS Free
- SVHC Free



Contact Information

For the latest specifications, additional product information, worldwide sales and distribution locations:

Web: www.qorvo.com

Tel: 1-844-890-8163

Email: customer.support@qorvo.com

For technical questions and application information:

Email: appsupport@qorvo.com

Important Notice

The information contained herein is believed to be reliable; however, Qorvo makes no warranties regarding the information contained herein and assumes no responsibility or liability whatsoever for the use of the information contained herein. All information contained herein is subject to change without notice. Customers should obtain and verify the latest relevant information before placing orders for Qorvo products. The information contained herein or any use of such information does not grant, explicitly or implicitly, to any party any patent rights, licenses, or any other intellectual property rights, whether with regard to such information itself or anything described by such information. **THIS INFORMATION DOES NOT CONSTITUTE A WARRANTY WITH RESPECT TO THE PRODUCTS DESCRIBED HEREIN, AND QORVO HEREBY DISCLAIMS ANY AND ALL WARRANTIES WITH RESPECT TO SUCH PRODUCTS WHETHER EXPRESS OR IMPLIED BY LAW, COURSE OF DEALING, COURSE OF PERFORMANCE, USAGE OF TRADE OR OTHERWISE, INCLUDING THE IMPLIED WARRANTIES OF MERCHANTABILITY AND FITNESS FOR A PARTICULAR PURPOSE.**

Without limiting the generality of the foregoing, Qorvo products are not warranted or authorized for use as critical components in medical, life-saving, or life-sustaining applications, or other applications where a failure would reasonably be expected to cause severe personal injury or death.

Copyright 2017 © Qorvo, Inc. | Qorvo is a registered trademark of Qorvo, Inc.

X-ON Electronics

Largest Supplier of Electrical and Electronic Components

Click to view similar products for [RF Amplifier](#) category:

Click to view products by [Qorvo](#) manufacturer:

Other Similar products are found below :

[A82-1](#) [BGA622H6820XTSA1](#) [BGA 728L7 E6327](#) [BGB719N7ESDE6327XTMA1](#) [HMC397-SX](#) [HMC405](#) [HMC561-SX](#) [HMC8120-SX](#)
[HMC8121-SX](#) [HMC-ALH382-SX](#) [HMC-ALH476-SX](#) [SE2433T-R](#) [SMA3101-TL-E](#) [SMA39](#) [A66-1](#) [A66-3](#) [A67-1](#) [LX5535LQ](#) [LX5540LL](#)
[MAAM02350](#) [HMC3653LP3BETR](#) [HMC549MS8GETR](#) [HMC-ALH435-SX](#) [SMA101](#) [SMA32](#) [SMA411](#) [SMA531](#) [SST12LP17E-XX8E](#)
[SST12LP19E-QX6E](#) [WPM0510A](#) [HMC5929LS6TR](#) [HMC5879LS7TR](#) [HMC1126](#) [HMC1087F10](#) [HMC1086](#) [HMC1016](#) [SMA1212](#)
[MAX2689EWS+T](#) [MAAMSS0041TR](#) [MAAM37000-A1G](#) [LTC6430AIUF-15#PBF](#) [CHA5115-QDG](#) [SMA70-2](#) [SMA4011](#) [A231](#) [HMC-](#)
[AUH232](#) [LX5511LQ](#) [LX5511LQ-TR](#) [HMC7441-SX](#) [HMC-ALH310](#)