

Product Overview

The TQM879008 is a digital variable gain amplifier (DVGA) featuring high linearity over the entire gain control range. This amplifier module integrates two gain blocks, a digital-step attenuator (DSA), and a high linearity 1/2 W amplifier. The module has the added feature of integrating all matching components, bias chokes and blocking capacitors. The internal 6-bit DSA provides a 31.5 dB gain control range in 0.5 dB steps, and is controlled with a serial periphery interface (SPITM).

The TQM879008 features variable gain from 10 dB to 41.1dB at 2.5 GHz, +47.5 dBm output IP3, and +27.3 dBm P1dB. The module operates from a single +5V supply and is available in a compact 28-pin 6x6 mm leadless SMT package.

The TQM879008 is pin compatible with the TQM829007 (0.7-1.0GHz, 0.25W DVGA) and TQM879006 (1.4-2.7GHz, 0.25W DVGA). This allows one to size the right type of device for specific system level requirements as well as making the DVGA family ideal for applications where a common PCB layout is used for different frequency bands.

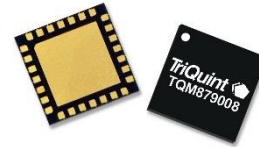

28-pin 6x6 mm leadless SMT Package

Key Features

- 1.4-2.7 GHz Frequency Range
- 41.1 dB Maximum Gain at 2.5 GHz
- 31.5 dB Gain Range in 0.5 dB Steps
- +47.5 dBm Output IP3
- +27.3 dBm Output P1dB
- Fully Internally Matched Module
- Integrated Blocking Capacitors, Bias Inductors
- 3-wire SPI Control Programming

Functional Block Diagram

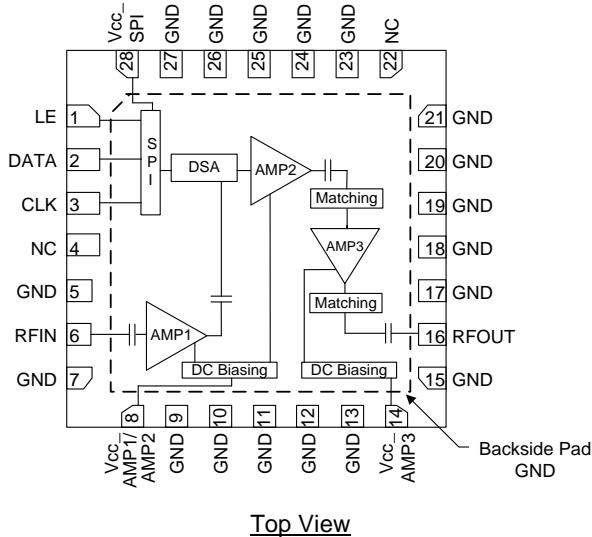

Applications

- 3G / 4G Wireless Infrastructure
- CDMA, WCDMA, LTE
- Repeaters
- ISM Infrastructure

Ordering Information

Part No.	Description
TQM879008TR13	2,500 pieces on a 13" reel (standard)
TQM879008-PCB	Evaluation Board, Includes USB control board, EVH



Absolute Maximum Ratings

Parameter	Rating
Storage Temperature	-55 to +150°C
RF Input Power, 50Ω, T = 25°C	+23 dBm
V _{DD} , Power Supply Voltage	+5.5 V
Digital Input Voltage	V _{CC} +0.5V

Exceeding any one or a combination of the Absolute Maximum Rating conditions may cause permanent damage to the device. Extended application of Absolute Maximum Rating conditions to the device may reduce device reliability.

Recommended Operating Conditions

Parameter	Min	Typ	Max	Units
V _{CC} (pins 8, 14, 28)	+4.75	+5.0	+5.25	V
Case Temperature	-40		+85	°C
T _j (for >10 ⁶ hours MTTF)			170	°C

Electrical specifications are measured at specified test conditions. Specifications are not guaranteed over all recommended operating conditions.

Electrical Specifications

Parameter	Conditions ⁽¹⁾	Min	Typ	Max	Units
Operational Frequency Range		1400		2700	MHz
Test Frequency			2500		
Gain		38	41.1	44	dB
Gain Control Range	0.5 dB Step Size		31.5		dB
Attenuation Accuracy	3 wire SPI, 6 states	± (0.3 + 5% of Atten. Setting) Max			dB
Control Interface	3-wire SPI		6		Bit
Input Return Loss			16		dB
Output Return Loss			14		dB
Output P1dB			+27.3		dBm
Output IP3	P _{out} = +11 dBm/tone, Δf=1MHz	+41	+47.5		dBm
Noise Figure			3.9		dB
I/O Impedance			50		Ω
Supply Voltage			+5		V
Supply Current		220	285	320	mA
Thermal Resistance, θ _{jc}	Module (junction to case)			20.5	°C/W

Notes:

1. Test conditions unless otherwise noted: V_{CC} = +5.0V, Temp = +25°C, 50Ω system.

TQM879008-PCB Evaluation Board

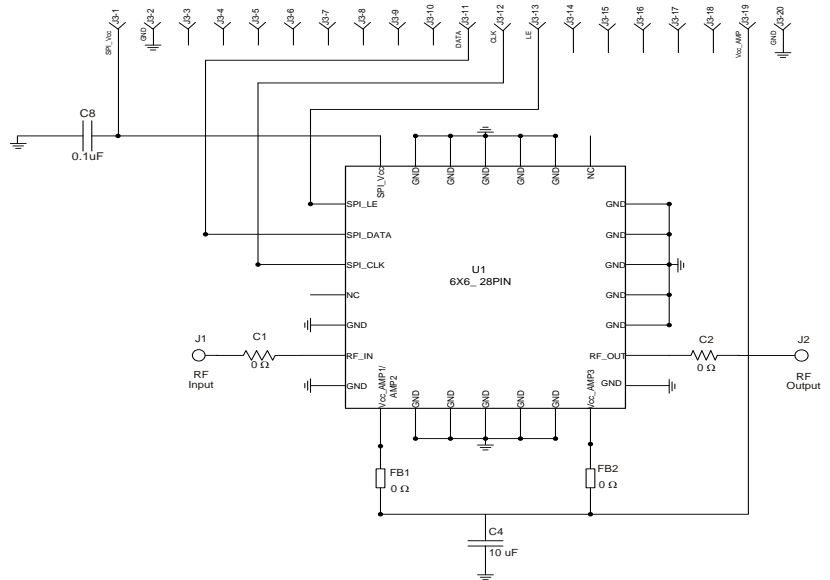
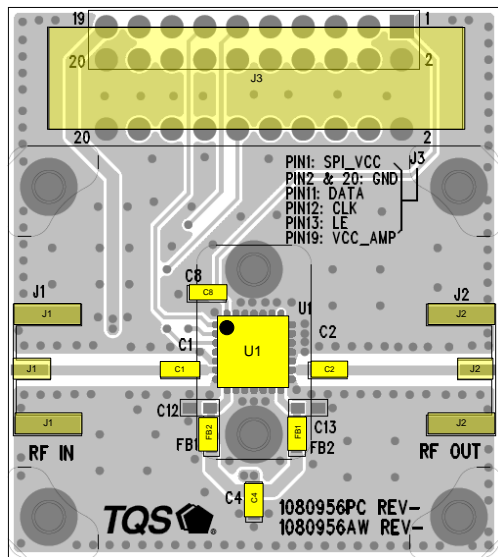

Notes:

1. See Evaluation Board PCB Information section for material and stack-up.
2. All Components are of 0603 size unless stated otherwise.
3. See Serial Control Interface section for SPI Timing Diagram.
4. 0 Ω jumpers may be replaced with copper traces in the target application layout.
5. Different ground pins are used for SPI (digital) and analog supply voltages.
6. The primary RF microstrip characteristic line impedance is 50 Ω .
7. The single power supply is used to provide supply voltage to AMP1, AMP2 and AMP3.

Bill of Material –TQM879008-PCB

Reference Des.	Value	Description	Manufacturer	Part Number
U1		0.6 – 1.0 GHz ¼ W DVGA	Qorvo	TQM879008
C8	0.1 uF	Cap, Chip, 0603, 16V, X7R, 10%	various	
C4	10 uF	Cap, Chip, 0603, 6.3V, X5R, 20%	various	
C1, C2, FB1, FB2	0 Ω	Res, Chip, 0603, 1/16W, 5%	various	

Typical Performance – TQM879008-PCB

Test conditions unless otherwise noted: $V_{CC}=+5$ V, Temp=25°C, 50 Ω system, Maximum Gain State

Parameter	Typical Value							Units
Frequency	1.5	1.9	2.1	2.3	2.5	2.7		GHz
Gain	41.7	41.8	41.7	41.5	41.1	41		dB
Input Return Loss	14.6	13.2	11	12	16	20		dB
Output Return Loss	6.2	9.2	11.7	13	14	12		dB
Output P1dB	+26.3	+26.7	+27.8	+27.8	+27.3	+27.0		dBm
Output IP3 (Pout=+11 dBm/tone, Δf =1 MHz)	+43.7	+40.3	+40.4	+43.5	+48.5	+45.0		dBm
WCDMA channel power at 50dBc ACLR	17.6	17.8	18.9	18.8	18.5	18		dBm

Typical Performance Plots – TQM879008-PCB

Test conditions unless otherwise specified: $V_{CC}=+5\text{ V}$, $\text{Temp}=+25^\circ\text{C}$, 50Ω system

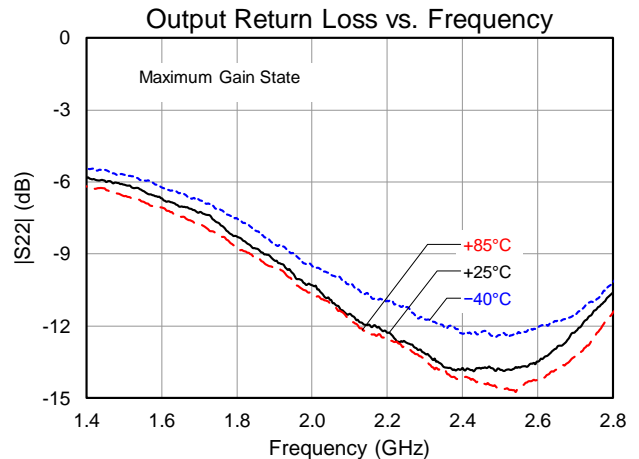
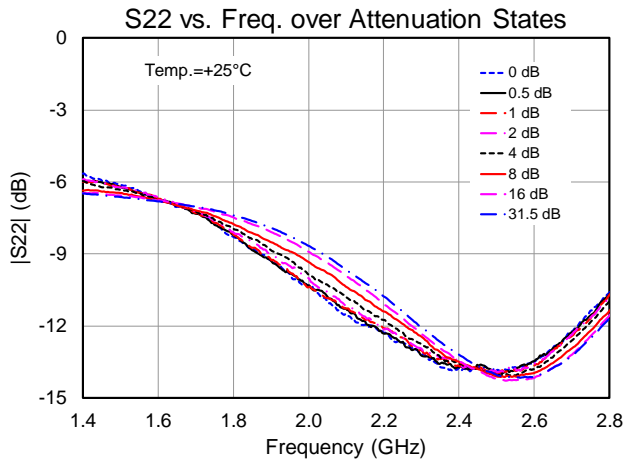
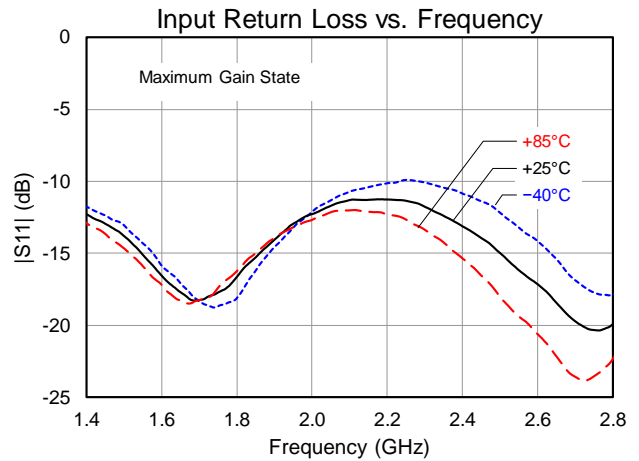
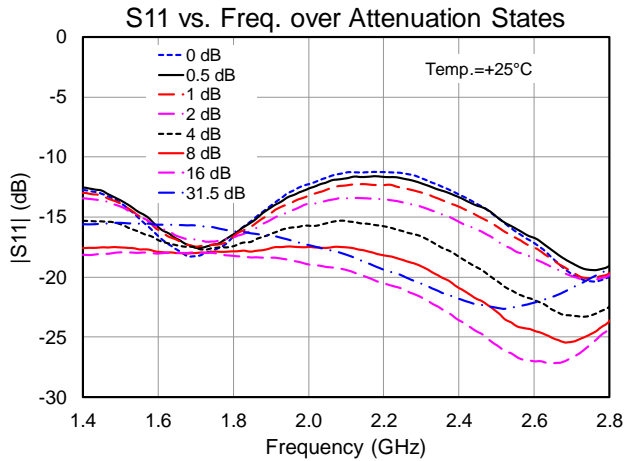
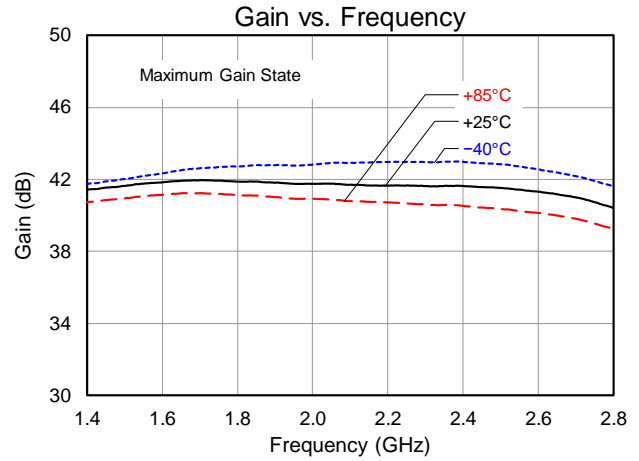
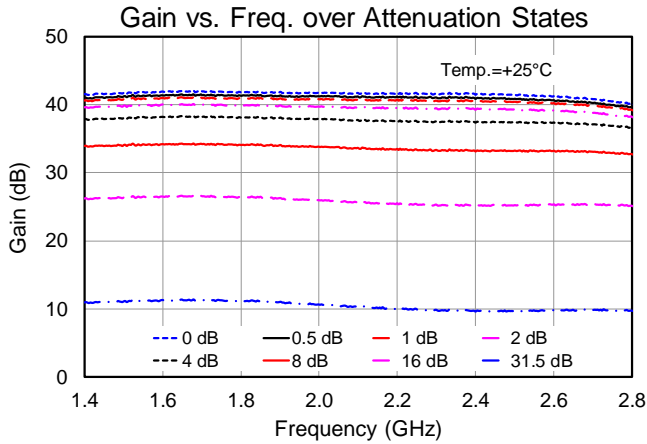

Typical Performance Plots – TQM879008-PCB

Test conditions unless otherwise specified: $V_{CC}=+5$ V, Temp= +25°C, 50Ω system

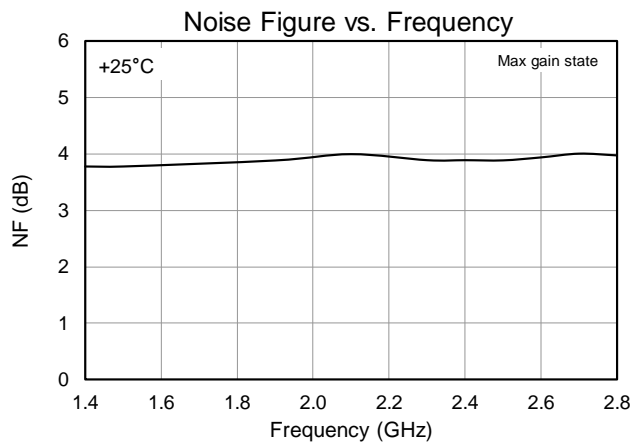
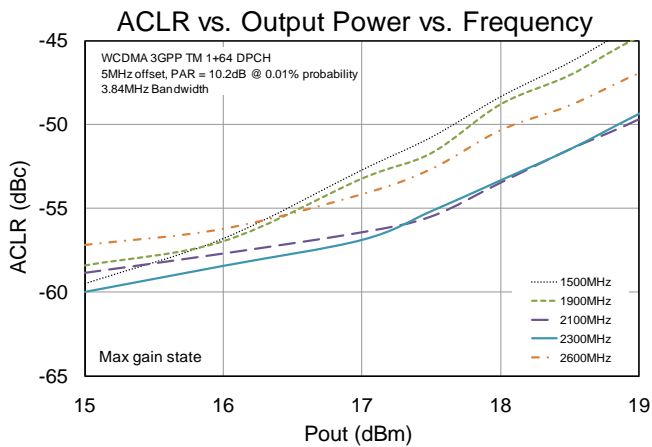
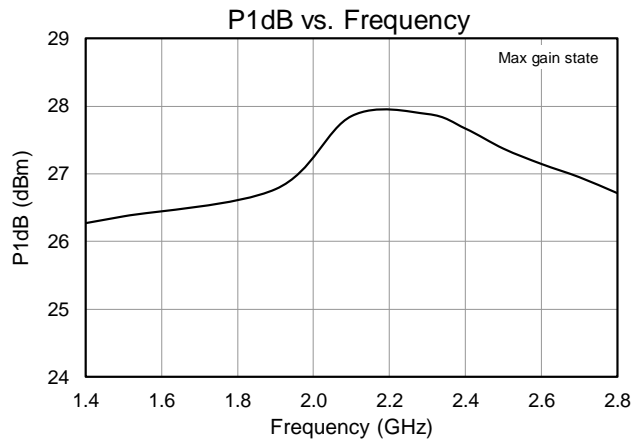
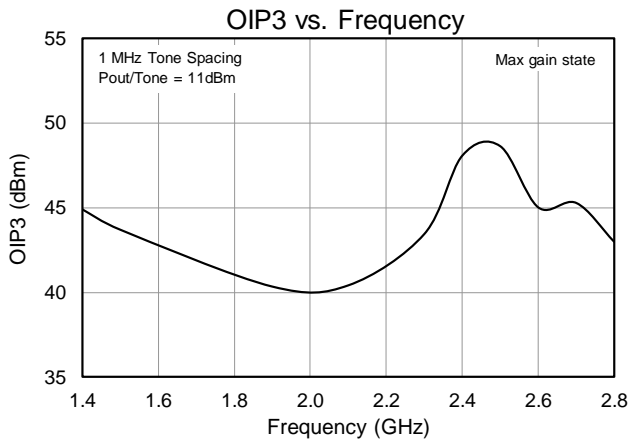
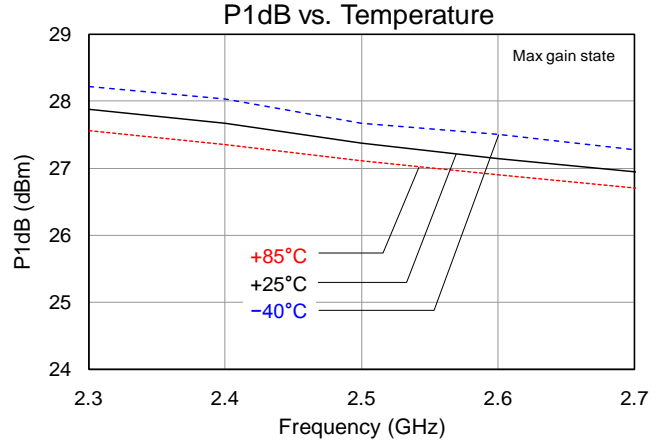
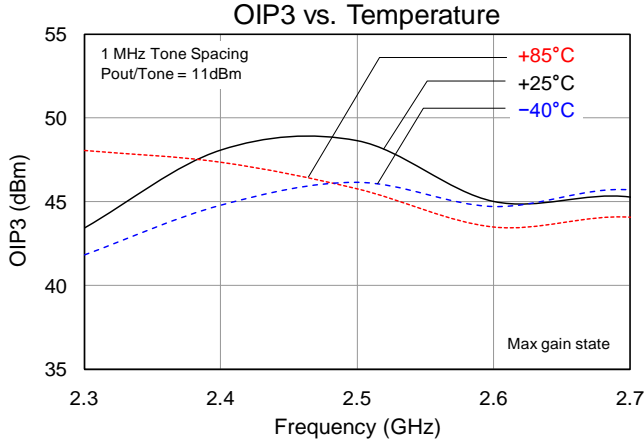

Serial Control Interface

The TQM879008 has a CMOS SPI™ input compatible serial interface. This serial control interface converts the serial data input stream to parallel output word. The input is 3-wire (CLK, LE and SID) SPI™ input compatible. At power up, the serial control interface resets the DSA to the minimum gain state. The 6-bit SID (Serial Input Data) word is loaded into the register on rising edge of the CLK, MSB first. When LE is high, CLK is internally disabled.

Serial Control Timing Characteristics (Test conditions: $V_{CC} = +5\text{ V}$, $\text{Temp.} = 25^\circ\text{C}$)

Parameter	Condition	Min	Max	Units
Clock Frequency	50% Duty Cycle		10	MHz
LE Setup Time, t_{LESUP}	after last CLK rising edge	10		ns
LE Pulse Width, t_{LEPW}		30		ns
SERIN set-up time, t_{SDSUP}	before CLK rising edge	10		ns
SERIN hold-time, t_{SDHLD}	after CLK rising edge	10		ns
LE Pulse Spacing t_{LE}	LE to LE pulse spacing	630		ns
Propagation Delay t_{PLO}	LE to Parallel output valid		30	ns

Serial Control DC Logic Characteristics (Test conditions: $V_{CC} = +5\text{ V}$, $\text{Temp.} = 25^\circ\text{C}$)

Parameter	Condition	Min	Max	Units
Input Low State Voltage, V_{IL}		0	0.8	V
Input High State Voltage, V_{IH}		2.4	V_{CC}	V
Input Current, I_{IH} / I_{IL}	On SID, LE and CLK pins	-10	+10	μA

SERIN Control Logic Truth Table

6-Bit Control Word						Attenuation State
MSB			LSB			
D5	D4	D3	D2	D1	D0	
1	1	1	1	1	1	Reference : IL
1	1	1	1	1	0	0.5 dB
1	1	1	1	0	1	1 dB
1	1	1	0	1	1	2 dB
1	1	0	1	1	1	4 dB
1	0	1	1	1	1	8 dB
0	1	1	1	1	1	16 dB
0	0	0	0	0	0	31.5 dB

Any combination of the possible 64 states will provide an attenuation of the sum of bits selected.

Timing Diagram

CLK is internally disabled when LE is high

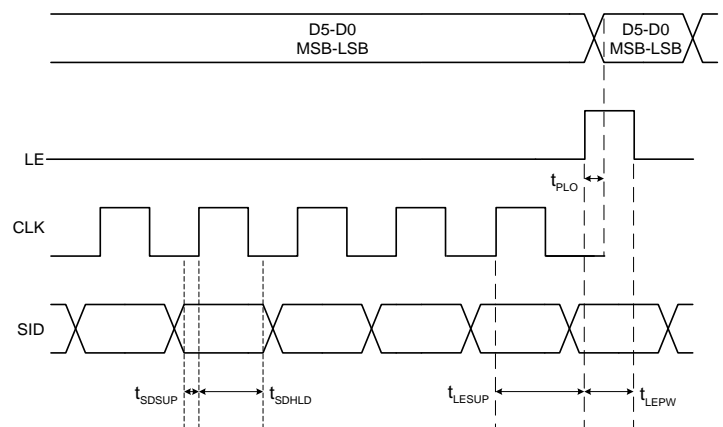

Detailed Device Description

The TQM879008 is a 50 Ω internally matched digital variable gain amplifier (DVGA) featuring high linearity over the entire gain control range. The amplifier module features the integration of two gain block, a digital-step attenuator (DSA), along with a high linearity ½ W amplifier. The module is unconditionally stable. Internal blocking capacitors and bias structures keep external parts count to a minimum. The DVGA has an operational frequency range from 1.4-2.7 GHz.

Functional Block Diagram

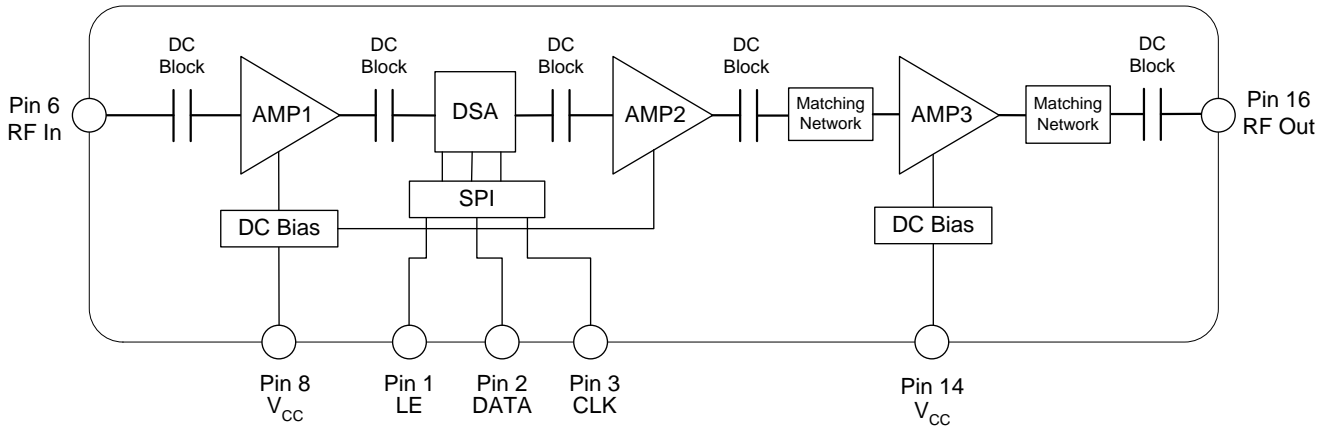

Chain Analysis Table

Test conditions: $V_{cc}=+5\text{ V}$, $Temp=+25^{\circ}\text{C}$, 50Ω system, Maximum Gain State, $Freq.=2500\text{ MHz}$

Parameter	AMP1	DSA	AMP2	AMP3	Overall Performance
Gain (dB)	14	-1.8	14	15	41.1
NF (dB)	3.9	1.8	2.0	4.5	3.9
OIP3 (dBm)	30	55	40	48	47.5
P1dB (dBm)	15	28.5	22	27.4	27.3
Icc (mA)	60	2.0	85	140	285

Pin Configuration and Description

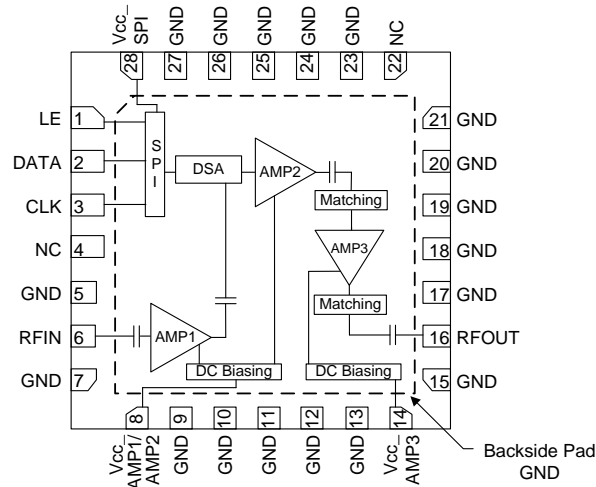

Pin No.	Label	Description
1	LE	Serial Latch Enable Input. When LE is high, latch is clear and content of SPI control the attenuator. When LE is low, data in SPI is latched.
2	DATA	Serial data input. The data and clock pins allow the data to be entered serially into SPI and is independent of Latch state.
3	CLK	Serial clock input.
4, 22	N/C	No connect or open. This pin is not connected in this module
6	RFIN	Input, matched to 50 ohms. Internally DC blocked.
8	VCC_AMP1/ AMP2	Supply Voltage to AMP1 and AMP2. This pin is connected internally to bypass capacitors followed by inductor inside the module.
14	VCC_AMP3	Supply Voltage to AMP3. This pin is connected internally to bypass capacitors followed by inductor inside the module.
16	RFOUT	Output matched to 50 ohms. Internally DC blocked.
28	VCC_SPI	SPI and DSA DC supply. This pin is connected to bypass capacitor internally.
5, 7, 9-13, 15, 17-21, 23-27	GND	RF/DC Ground Connection
Backside Pad	GND	RF/DC Ground Connection

Evaluation Board PCB Information

Qorvo PCB 1080956 Material and Stack-up

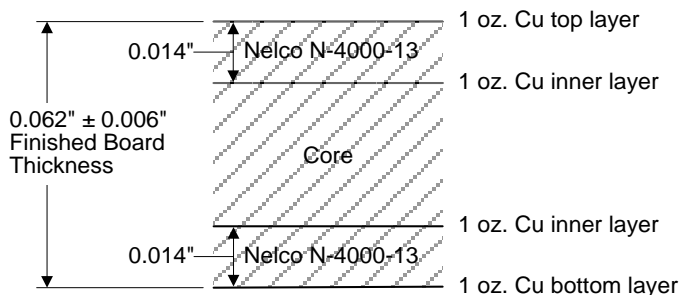

Microstrip line details: width = .030", spacing = .036".

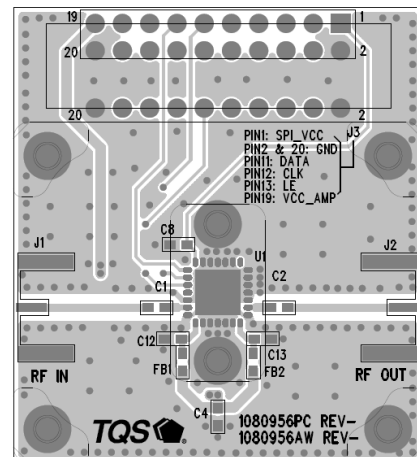

Package Marking and Dimensions

Marking: Part number – TQM879008
 Year/week code – YYWW
 Country code – CCCC
 TraceCode – up to 6 characters long

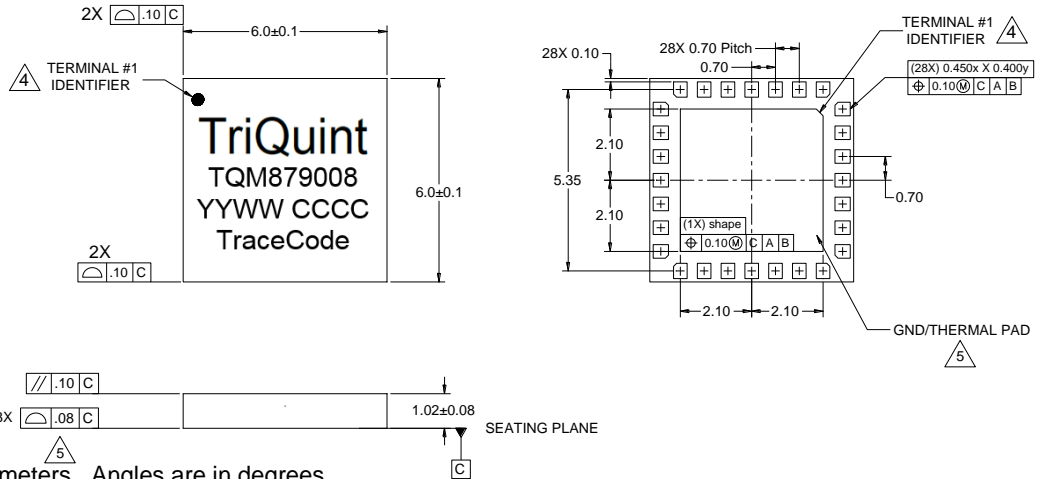

Notes:

1. All dimensions are in millimeters. Angles are in degrees.
2. Dimension and tolerance formats conform to ASME Y14.4M-1994.
3. The terminal #1 identifier and terminal numbering conform to JESD 95-1 SPP-012.
4. Co-planarity applies to the exposed ground/thermal pad as well as the contact pins.
5. Package body length/width does not include plastic flash protrusion across mold parting line.

PCB Mounting Pattern

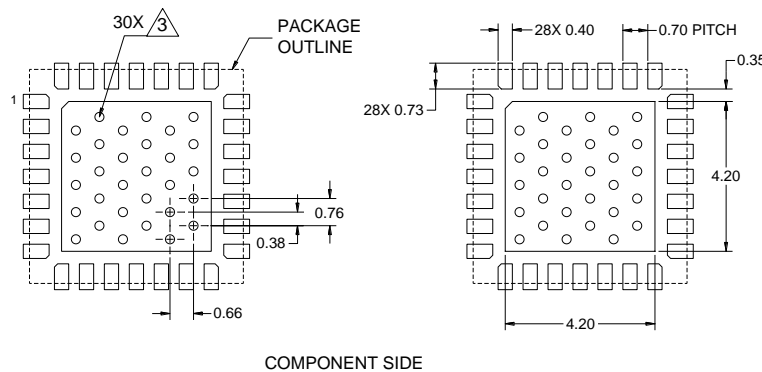

Notes:

1. All dimensions are in millimeters. Angles are in degrees.
2. Use 1 oz. copper minimum for top and bottom layer metal.
3. Vias are required under the backside paddle of this device for proper RF/DC grounding and thermal dissipation. We recommend a 0.35mm (#80/.0135") diameter bit for drilling via holes and a final plated thru diameter of 0.25 mm (0.10").
4. Ensure good package backside paddle solder attach for reliable operation and best electrical performance.

Handling Precautions

Parameter	Rating	Standard
ESD – Human Body Model (HBM)	Class 1C	ESDA / JEDEC JS-001-2012
ESD – Charged Device Model (CDM)	Class C3	JEDEC JESD22-C101F
MSL – Moisture Sensitivity Level	Level 3	IPC/JEDEC J-STD-020



Caution!
ESD-Sensitive Device

Solderability

Compatible with both lead-free (260°C max. reflow temp.) and tin/lead (245°C max. reflow temp.) soldering processes.

Solder profiles available upon request.

Contact plating: Electrolytic plated Au over Ni

RoHS Compliance

This part is compliant with EU 2011/65/EU RoHS directive (Restrictions on the Use of Certain Hazardous Substances in Electrical and Electronic Equipment) as amended by Directive 2015/863/EU. This product also has the following attributes:

- Product uses RoHS Exemption 7c-I to meet RoHS Compliance requirements.
- Halogen Free (Chlorine, Bromine)
- Antimony Free
- TBBP-A (C₁₅H₁₂Br₄O₂) Free
- PFOS Free
- SVHC Free

Contact Information

For the latest specifications, additional product information, worldwide sales and distribution locations:

Tel: **1-844-890-8163**

Web: www.qorvo.com

Email: customer.support@qorvo.com

For technical questions and application information: Email: appsupport@qorvo.com

Important Notice

The information contained herein is believed to be reliable; however, Qorvo makes no warranties regarding the information contained herein and assumes no responsibility or liability whatsoever for the use of the information contained herein. All information contained herein is subject to change without notice. Customers should obtain and verify the latest relevant information before placing orders for Qorvo products. The information contained herein or any use of such information does not grant, explicitly or implicitly, to any party any patent rights, licenses, or any other intellectual property rights, whether with regard to such information itself or anything described by such information. **THIS INFORMATION DOES NOT CONSTITUTE A WARRANTY WITH RESPECT TO THE PRODUCTS DESCRIBED HEREIN, AND QORVO HEREBY DISCLAIMS ANY AND ALL WARRANTIES WITH RESPECT TO SUCH PRODUCTS WHETHER EXPRESS OR IMPLIED BY LAW, COURSE OF DEALING, COURSE OF PERFORMANCE, USAGE OF TRADE OR OTHERWISE, INCLUDING THE IMPLIED WARRANTIES OF MERCHANTABILITY AND FITNESS FOR A PARTICULAR PURPOSE.**

Without limiting the generality of the foregoing, Qorvo products are not warranted or authorized for use as critical components in medical, life-saving, or life-sustaining applications, or other applications where a failure would reasonably be expected to cause severe personal injury or death.

Copyright 2017 © Qorvo, Inc. | Qorvo is a registered trademark of Qorvo, Inc.

X-ON Electronics

Largest Supplier of Electrical and Electronic Components

Click to view similar products for [RF Amplifier](#) category:

Click to view products by [Qorvo](#) manufacturer:

Other Similar products are found below :

[A82-1](#) [BGA622H6820XTSA1](#) [BGA 728L7 E6327](#) [BGB719N7ESDE6327XTMA1](#) [HMC397-SX](#) [HMC405](#) [HMC561-SX](#) [HMC8120-SX](#)
[HMC8121-SX](#) [HMC-ALH382-SX](#) [HMC-ALH476-SX](#) [SE2433T-R](#) [SMA3101-TL-E](#) [SMA39](#) [A66-1](#) [A66-3](#) [A67-1](#) [A81-2](#) [LX5535LQ](#)
[LX5540LL](#) [MAAM02350](#) [HMC3653LP3BETR](#) [HMC549MS8GETR](#) [HMC-ALH435-SX](#) [SMA101](#) [SMA32](#) [SMA411](#) [SMA531](#)
[SST12LP19E-QX6E](#) [WPM0510A](#) [HMC5929LS6TR](#) [HMC5879LS7TR](#) [HMC1126](#) [HMC1087F10](#) [HMC1086](#) [HMC1016](#) [SMA1212](#)
[MAX2689EWS+T](#) [MAAMSS0041TR](#) [MAAM37000-A1G](#) [LTC6430AIUF-15#PBF](#) [SMA70-2](#) [SMA4011](#) [A231](#) [HMC-AUH232](#) [LX5511LQ](#)
[LX5511LQ-TR](#) [HMC7441-SX](#) [HMC-ALH310](#) [XD1001-BD-000V](#)