



3-pin SOT-89 Package

General Description

The TQP3M9008 is a cascade-able, high linearity gain block amplifier in a low-cost surface-mount package. At 1.9 GHz, the amplifier typically provides 20.6 dB gain, +36 dBm OIP3, and 1.3 dB Noise Figure while only drawing 85 mA current. The device is housed in a lead-free/green/RoHS-compliant industry-standard SOT-89 package.

The TQP3M9008 has the benefit of having high gain across a broad range of frequencies while also providing very low noise. This allows the device to be used in both receiver and transmitter chains for high performance systems. The amplifier is internally matched using a high-performance E-pHEMT process and only requires an external RF choke and blocking/bypass capacitors for operation from a single +5 V supply. The internal active bias circuit also enables stable operation over bias and temperature variations.

The TQP3M9008 covers the 0.05 – 4 GHz frequency band and is targeted for wireless infrastructure or other applications requiring high linearity and/or low noise figure.

Product Features

- 50 – 4000 MHz
- 20.6 dB Gain at 1.9 GHz
- +36 dBm Output IP3
- 1.3 dB Noise Figure at 1.9 GHz
- 50 Ohm Cascadable Gain Block
- Unconditionally stable
- High input power capability
- +5 V Single Supply, 85 mA Current
- SOT-89 Package

Applications

- Repeaters
- Mobile Infrastructure
- LTE / WCDMA / EDGE / CDMA
- General Purpose Wireless

Functional Block Diagram

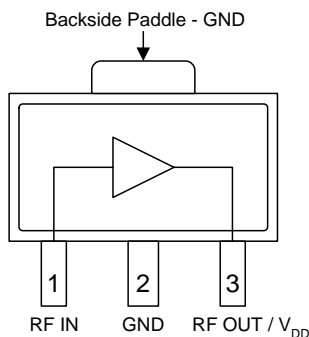

Ordering Information

Part No.	Description
TQP3M9008	High Linearity LNA Gain Block
TQP3M9008-PCB_IF	0.05–0.5 GHz Evaluation Board
TQP3M9008-PCB_RF	0.5–4.0 GHz Evaluation Board

Standard T/R size = 1000 pieces on a 7" reel

Absolute Maximum Ratings

Parameter	Rating
Storage Temperature	-65 to 150 °C
RF Input Power, CW, 50Ω, T=25°C	+23 dBm
Device Voltage (V _{DD})	+7 V
Reverse Device Voltage	-0.3 V

Exceeding any one or a combination of the Absolute Maximum Rating conditions may cause permanent damage to the device.

Recommended Operating Conditions

Parameter	Min	Typ	Max	Units
Device Voltage (V _{DD})	+3.0	+5.0	+5.25	V
T _{CASE}	-40		+105	°C
T _j for >10 ⁶ hours MTTF			+190	°C

Electrical specifications are measured at specified test conditions. Specifications are not guaranteed over all recommended operating conditions. Application of conditions to the device outside the Recommended Operating Conditions may reduce device reliability and performance.

Electrical Specifications

Test conditions unless otherwise noted: V_{DD} = +5 V, Temp. = +25 °C, 50 Ω system

Parameter	Conditions	Min	Typ	Max	Units
Operational Frequency Range		50		4000	MHz
Test Frequency			1900		MHz
Gain		19	20.6	22	dB
Input Return Loss			16		dB
Output Return Loss			17		dB
Output P1dB			+20		dBm
Output IP3	P _{out} = +3 dBm/tone, Δf = 1 MHz	+32.5	+36		dBm
Noise Figure			1.3		dB
Current, I _{DD}			85	100	mA
Thermal Resistance, θ _{jc}	Junction to case			38.7	°C/W

S-Parameters

Test Conditions: $V_{DD} = +5\text{ V}$, $I_{DD} = 85\text{ mA}$, Temp. = $+25\text{ }^{\circ}\text{C}$, $50\text{ }\Omega$ system, calibrated to device leads

Freq (MHz)	S11 (dB)	S11 (ang)	S21 (dB)	S21 (ang)	S12 (dB)	S12 (ang)	S22 (dB)	S22 (ang)
50	-12.5	-170.0	23.6	172.9	-26.7	0.6	-9.8	177.2
100	-11.9	-175.1	23.5	167.7	-26.7	-1.9	-9.9	171.9
200	-11.4	178.0	23.1	159.5	-26.6	-5.5	-10.0	162.2
400	-11.4	167.0	22.7	144.1	-26.7	-12.9	-10.5	145.5
600	-11.6	154.1	22.3	129.4	-26.7	-19.6	-10.7	129.3
800	-11.8	147.2	22.0	114.6	-26.7	-26.1	-11.3	111.8
1000	-12.3	139.1	21.7	99.5	-26.8	-33.4	-12.4	94.3
1200	-12.7	132.1	21.4	85.6	-26.9	-39.9	-13.1	77.8
1400	-13.3	126.3	21.0	71.0	-27.1	-47.7	-14.3	58.7
1600	-13.6	116.9	20.8	56.2	-27.4	-56.5	-15.4	36.8
1800	-13.9	110.2	20.5	41.8	-27.6	-63.3	-16.3	15.3
2000	-14.3	103.5	20.3	27.9	-28.1	-71.6	-17.5	-11.2
2200	-15.1	94.6	19.9	13.8	-28.5	-80.2	-18.0	-39.1
2400	-15.8	85.2	19.7	-1.1	-28.7	-88.9	-17.4	-65.9
2600	-16.8	72.7	19.5	-16.0	-29.4	-96.8	-16.6	-94.2
2800	-18.0	55.2	19.2	-31.3	-29.9	-105.7	-14.9	-115.0
3000	-19.8	25.5	19.0	-46.9	-30.6	-117.1	-14.1	-131.7
3200	-19.9	-16.8	18.6	-63.5	-31.0	-128.0	-13.1	-148.3
3400	-17.8	-59.0	18.3	-80.5	-31.8	-139.4	-12.4	-160.2
3600	-14.3	-90.8	17.7	-98.5	-32.8	-154.4	-11.9	-173.9
3800	-11.3	-114.3	17.0	-117.1	-34.0	-168.1	-11.2	174.5
4000	-8.7	-132.7	16.1	-135.8	-34.8	173.1	-10.7	167.6

TQP3M9008-PCB_IF / RF Evaluation Board

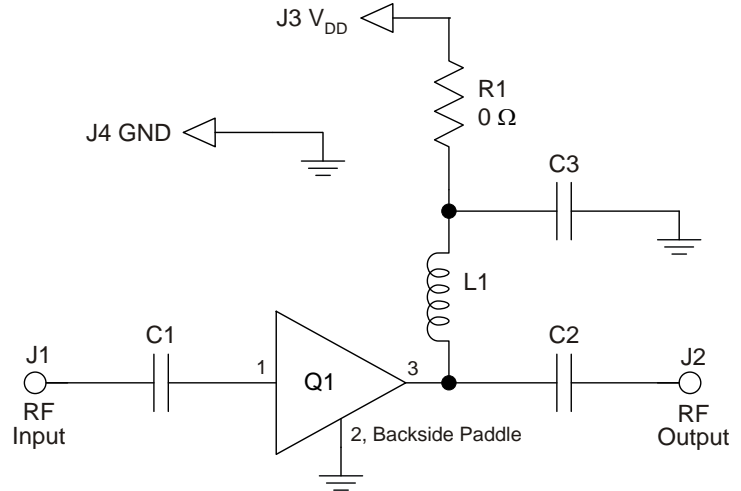
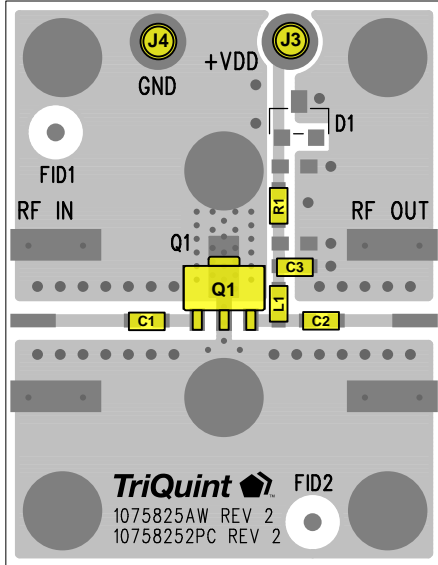

Notes:

1. See Evaluation Board PCB section for material and stack-up.
2. Components shown on the silkscreen but not on the schematic are not used.
3. R1 (0 Ω jumper) may be replaced with copper trace in the target application layout.
4. The recommended component values are dependent upon the frequency of operation.
5. All components are of 0603 size unless stated on the schematic.

Bill of Material – TQP3M9008-PCB_IF / RF

Reference Designation	TQP3M9008-PCB_IF (50~500 MHz)	TQP3M9008-PCB_RF (500~4000MHz)
Q1	TQP3M9008	TQP3M9008
C1, C2	1000 pF	100 pF
C3	0.01 μF	0.01 μF
L1	330 nH	68 nH
D1	Do Not Place	
R1	0 Ω	

Performance can be optimized at frequency of interest by using recommended component values shown in the table below.

Reference Designation	500 (MHz)	2000 (MHz)	2500 (MHz)	3500 (MHz)
C1, C2	100 pF	22 pF	22 pF	22 pF
L1	82 nH	22 nH	18 nH	15 nH

Typical Performance – TQP3M9008-PCB_RF

Test conditions unless otherwise noted: $V_{DD}=+5\text{ V}$, $I_{DD}=85\text{ mA}$, $\text{Temp}=+25\text{ }^{\circ}\text{C}$, $50\ \Omega$ system

Parameter	Typical Value						Units
Frequency	500	900	1900	2700	3500	4000	MHz
Gain	22.8	22.3	20.6	19.0	17.6	16.0	dB
Input Return Loss	10	12	16	18	10	7.3	dB
Output Return Loss	9.5	12	17	13	12.4	14	dB
Output P1dB	+20.9	+19.7	+19.9	+19.4	+19.7	+18.5	dBm
OIP3	+37.5	+37.6	+36	+35.3	+34.7	+33.7	dBm
Noise figure	1.1	1.1	1.3	1.6	2	2.5	dB

Notes:

- OIP3 measured with two tones at an output power of +3 dBm / tone separated by 1 MHz.
- Noise figure values in the table above includes board losses. Approx. =0.1dB at 2 GHz.

Performance Plots – TQP3M9008-PCB_RF

Test conditions unless otherwise noted: $V_{DD} = +5\text{ V}$, $I_{DD} = 85\text{ mA}$, $\text{Temp.} = +25\text{ }^{\circ}\text{C}$, $50\ \Omega$ system

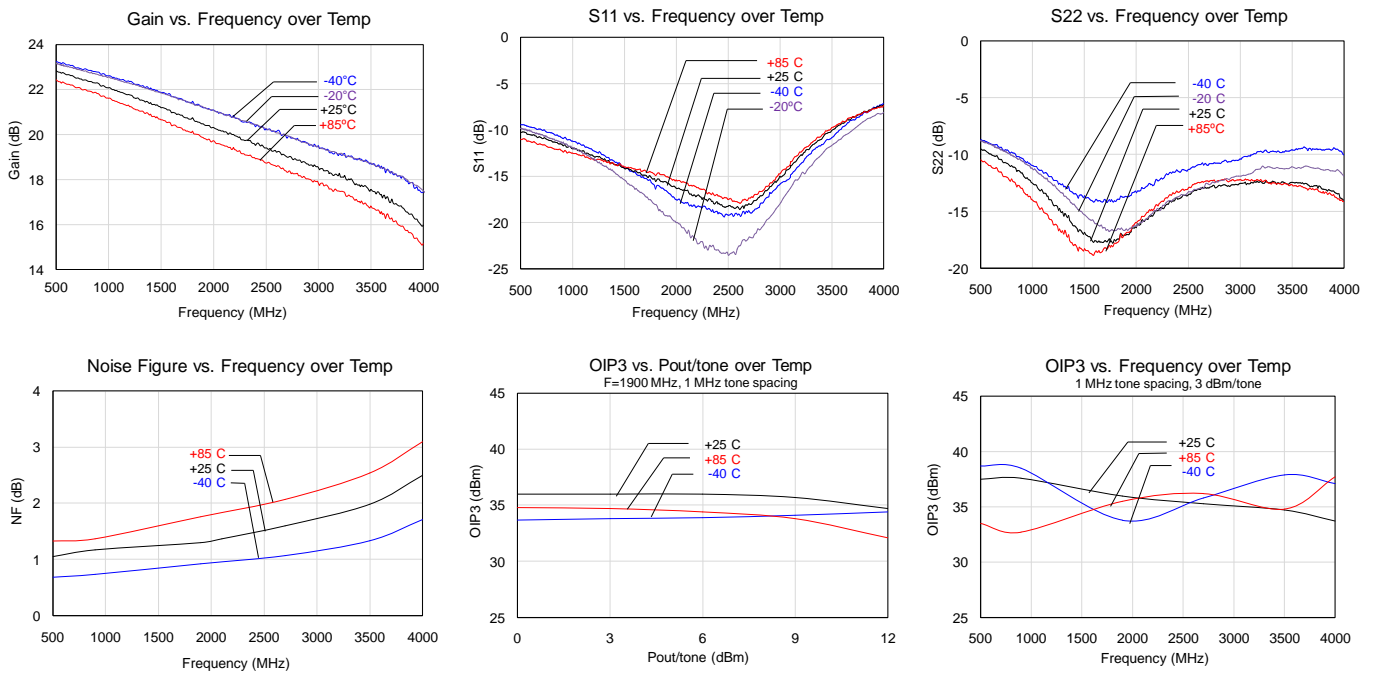

Performance Plots – TQP3M9008-PCB_RF

Test conditions unless otherwise noted: $V_{DD} = +5\text{ V}$, $I_{DD} = 85\text{ mA}$, Temp. = $+25\text{ }^{\circ}\text{C}$, $50\ \Omega$ system

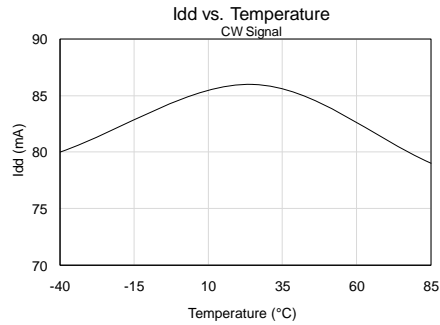
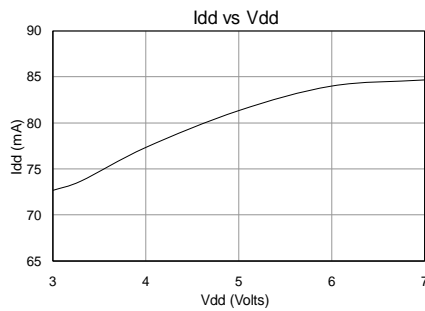
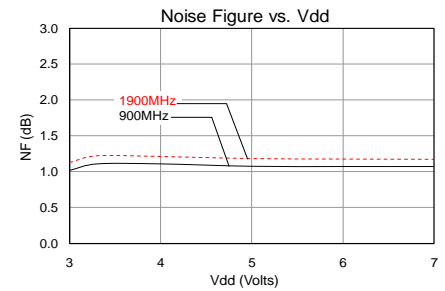
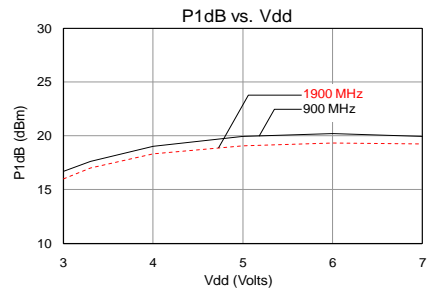
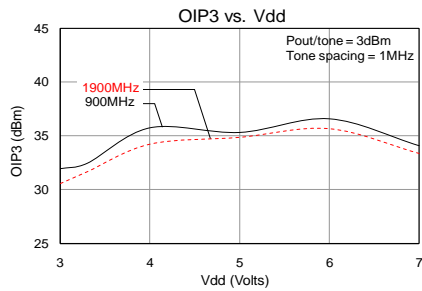
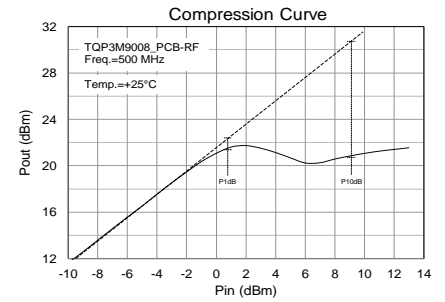
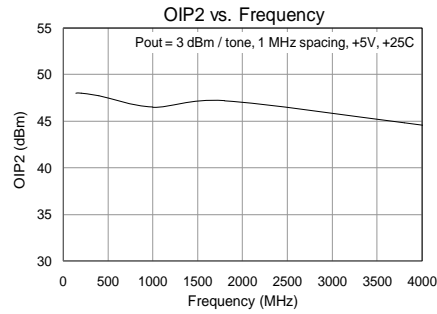
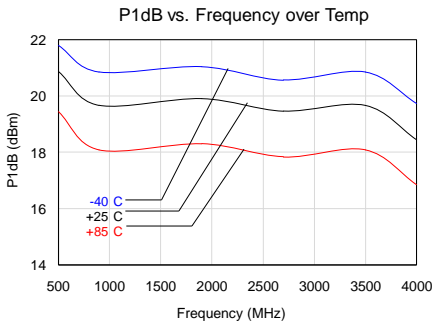

Typical Performance – TQP3M9008-PCB_IF

Test conditions unless otherwise noted: $V_{DD} = +5\text{ V}$, $I_{DD} = 85\text{ mA}$, Temp. = $+25\text{ }^{\circ}\text{C}$, $50\ \Omega$ system

Parameter	Typical Value				Units
Frequency	70	100	200	500	MHz
Gain	23.2	23.2	22.9	22.3	dB
Input Return Loss	10	11	11	11	dB
Output Return Loss	9	9	10	10	dB
Output P1dB	+19.8	+20.2	+19.9	+19.9	dBm
OIP3	+37	+37	+37	+37	dBm
Noise figure	1.2	1.1	0.8	1.1	dB

Notes:

1. OIP3 measured with two tones at an output power of +3 dBm / tone separated by 1 MHz.
2. Noise figure values in the table above includes board losses. Approx. =0.1dB at 2 GHz.

Performance Plots – TQP3M9008-PCB_IF

Test conditions unless otherwise noted: $V_{DD} = +5\text{ V}$, $I_{DD} = 85\text{ mA}$, Temp = $+25\text{ }^{\circ}\text{C}$, $50\ \Omega$ system.

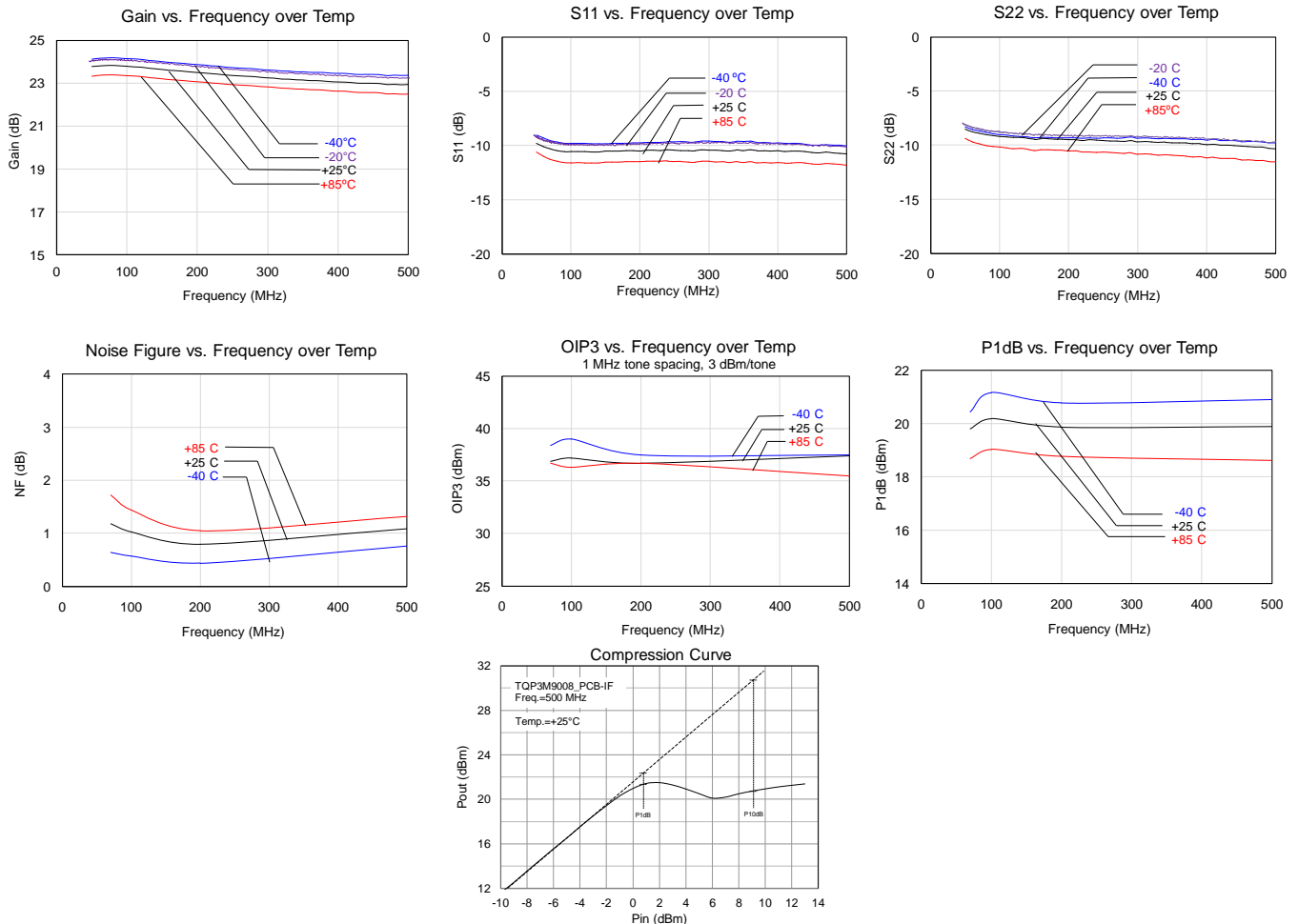

Pin Configuration and Description

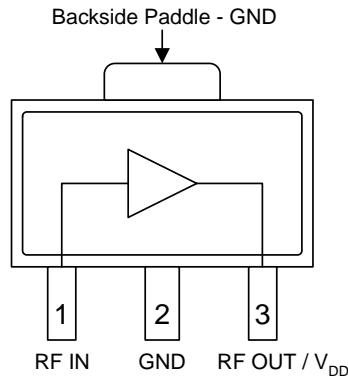

Pin No.	Label	Description
1	RF IN	RF input; matched to 50 Ω. External DC Block is required.
2, Backside Paddle	GND	RF/DC ground. Use recommended via hole pattern to minimize inductance and thermal resistance. See PCB Mounting Pattern for suggested footprint.
3	RF OUT / V _{DD}	RF output; matched to 50 Ω. External DC Block and bias voltage required.

Evaluation Board PCB

Qorvo PCB 1075825 Material and Stack-up

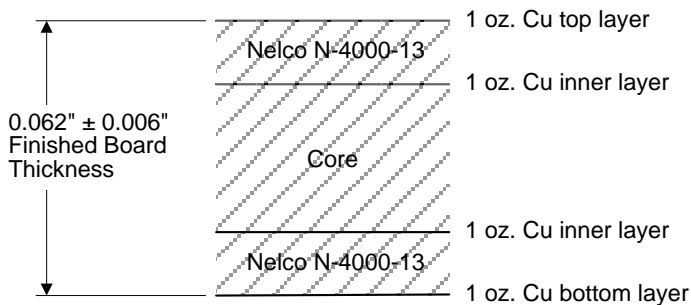

50 Ω line dimensions: width = .028", spacing = .028"

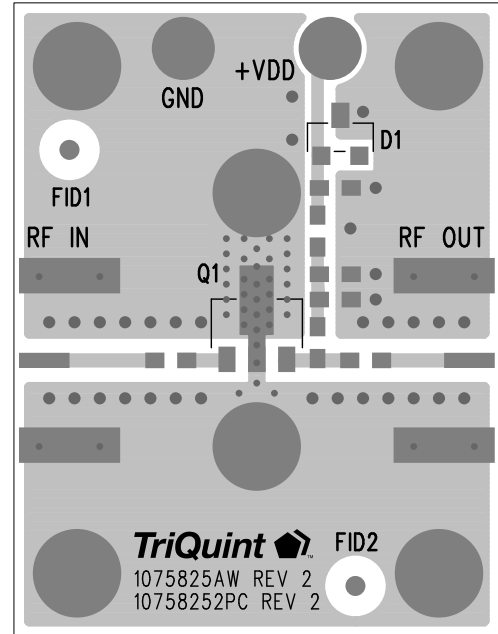

Package Marking and Dimensions

Marking: Product Identifier: 3M9008
Trace Code: XXXX – Assigned by sub-contractor

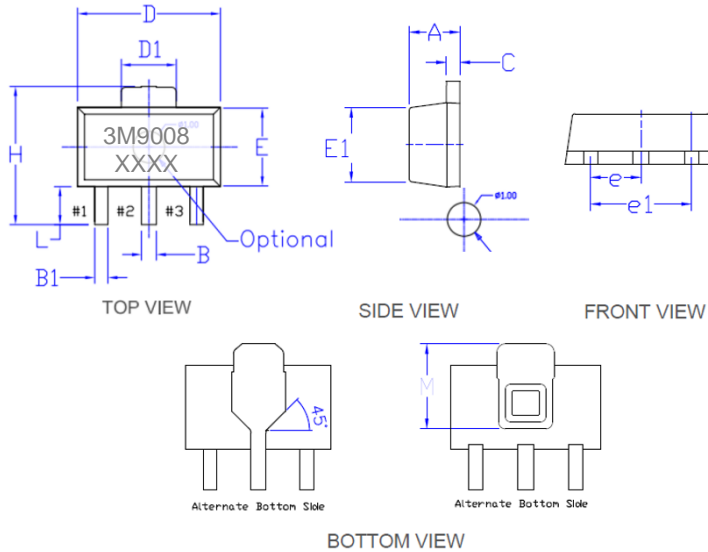

SYMBOLS	DIMENSIONS IN MILLIMETERS		
	MIN	NOM	MAX
A	1.40	1.50	1.60
B	0.41	0.49	0.58
B1	0.34	0.42	0.50
C	0.35	0.40	0.44
D	4.40	4.50	4.60
D1	1.40	1.67	1.83
E	2.30	2.50	2.60
E1	1.77	2.31	2.57
e	1.45	1.50	1.55
e1	2.90	3.00	3.10
H	3.94	4.10	4.25
L	0.80	1.05	1.20
M	2.36 ref		

- Notes:
1. The terminal #1 identifier and terminal numbering conform to JESD 95-1 SPP-012.
 2. Trace code up to 4 characters to be assigned by sub-contractor.

PCB Mounting Pattern

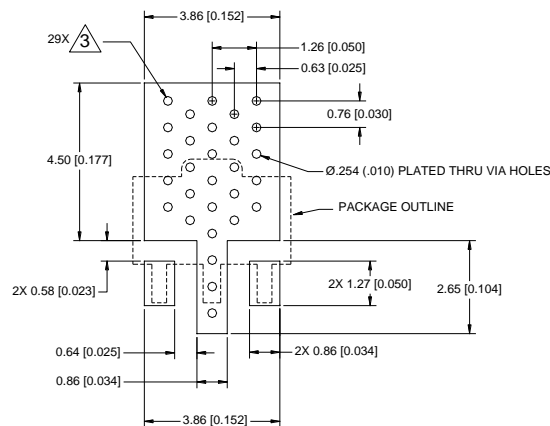

- Notes:
1. All dimensions are in millimeters[inches]. Angles are in degrees.
 2. Use 1 oz. copper minimum for top and bottom layer metal.
 3. Via holes are required under the backside paddle of this device for proper RF/DC grounding and thermal dissipation. We recommend a 0.35mm (#80/.0135") diameter bit for drilling via holes and a final plated thru diameter of 0.25mm (0.01").
 4. Ensure good package backside paddle solder attach for reliable operation and best electrical performance

Tape and Reel Information – Carrier and Cover Tape Dimensions

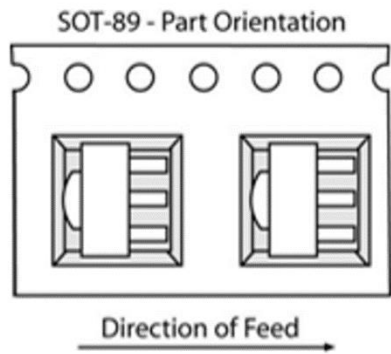
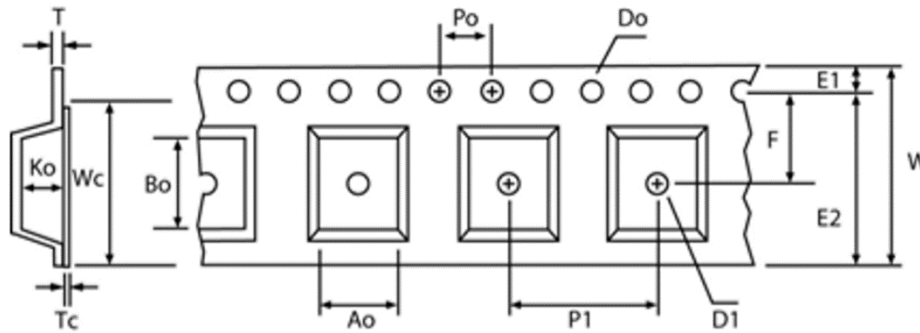

Feature	Measure	Symbol	Size (in)	Size (mm)
Cavity	Length	A0	0.181	4.60
	Width	B0	0.193	4.90
	Depth	K0	0.075	1.90
	Pitch	P1	0.315	8.00
Centerline Distance	Cavity to Perforation - Length Direction	P2	0.079	2.00
	Cavity to Perforation - Width Direction	F	0.217	5.50
Cover Tape	Width	C	0.362	9.20
Carrier Tape	Width	W	0.472	12.0

Tape and Reel Information – Reel Dimensions

Standard T/R size = 1,000 pieces on a 7" reel.

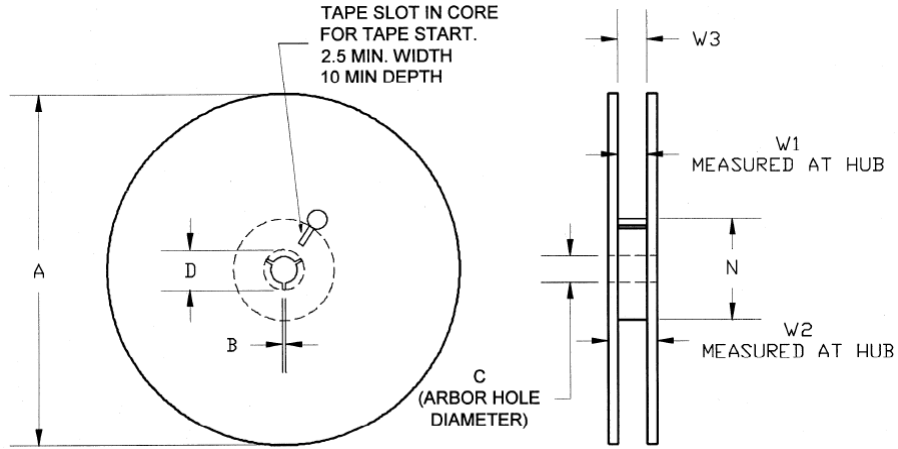

Feature	Measure	Symbol	Size (in)	Size (mm)
Flange	Diameter	A	6.969	170.0
	Thickness	W2	0.717	18.2
	Space Between Flange	W1	0.504	12.8
Hub	Outer Diameter	N	2.283	58.0
	Arbor Hole Diameter	C	0.512	13.0
	Key Slit Width	B	0.079	2.0
	Key Slit Diameter	D	0.787	20.0

Tape and Reel Information – Tape Length and Label Placement

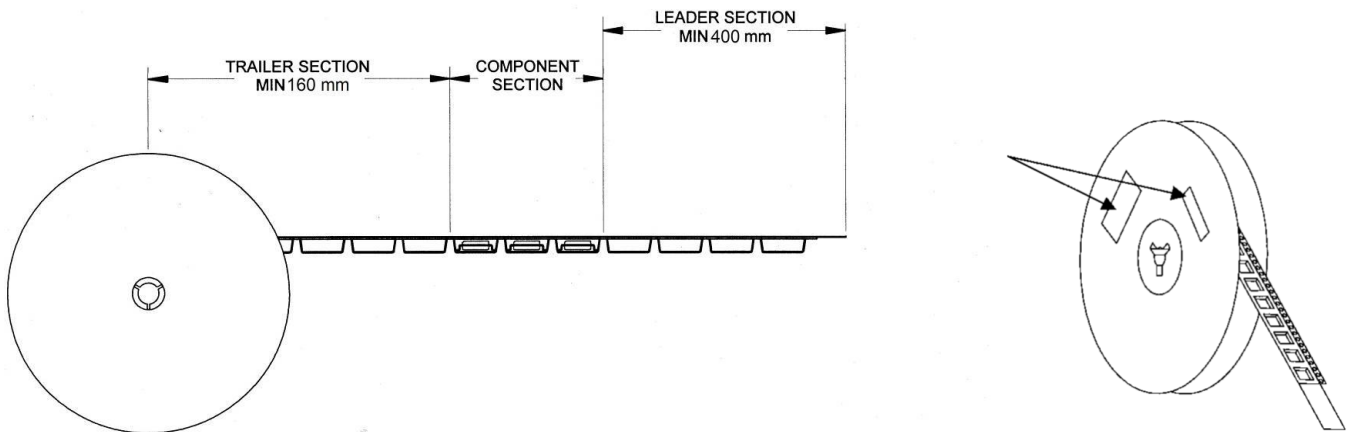

- Notes:
1. Empty part cavities at the trailing and leading ends are sealed with cover tape. See EIA 481-1-A.
 2. Labels are placed on the flange opposite the sprockets in the carrier tape.

Handling Precautions

Parameter	Rating	Standard
ESD – Human Body Model (HBM)	Class 1A	ESDA / JEDEC JS-001-2012
ESD – Charged Device Model (CDM)	Class C3	JEDEC JESD22-C101F
MSL – Moisture Sensitivity Level	Level 3	IPC/JEDEC J-STD-020



Caution!
 ESD-Sensitive Device

Solderability

Compatible with both lead-free (260°C max. reflow temp.) and tin/lead (245°C max. reflow temp.) soldering processes. Solder profiles available upon request.

Contact plating: Annealed Matte Tin or Nickle Palladium Gold (NiPdAu)

RoHS Compliance

This part is compliant with 2011/65/EU RoHS directive (Restrictions on the Use of Certain Hazardous Substances in Electrical and Electronic Equipment) as amended by Directive 2015/863/EU.

This product also has the following attributes:

- Lead Free
- Halogen Free (Chlorine, Bromine)
- Antimony Free
- TBBP-A (C₁₅H₁₂Br₄O₂) Free
- PFOS Free
- SVHC Free



Contact Information

For the latest specifications, additional product information, worldwide sales and distribution locations:

Web: www.qorvo.com

Tel: 1-844-890-8163

Email: customer.support@qorvo.com

Important Notice

The information contained herein is believed to be reliable; however, Qorvo makes no warranties regarding the information contained herein and assumes no responsibility or liability whatsoever for the use of the information contained herein. All information contained herein is subject to change without notice. Customers should obtain and verify the latest relevant information before placing orders for Qorvo products. The information contained herein or any use of such information does not grant, explicitly or implicitly, to any party any patent rights, licenses, or any other intellectual property rights, whether with regard to such information itself or anything described by such information. **THIS INFORMATION DOES NOT CONSTITUTE A WARRANTY WITH RESPECT TO THE PRODUCTS DESCRIBED HEREIN, AND QORVO HEREBY DISCLAIMS ANY AND ALL WARRANTIES WITH RESPECT TO SUCH PRODUCTS WHETHER EXPRESS OR IMPLIED BY LAW, COURSE OF DEALING, COURSE OF PERFORMANCE, USAGE OF TRADE OR OTHERWISE, INCLUDING THE IMPLIED WARRANTIES OF MERCHANTABILITY AND FITNESS FOR A PARTICULAR PURPOSE.**

Without limiting the generality of the foregoing, Qorvo products are not warranted or authorized for use as critical components in medical, life-saving, or life-sustaining applications, or other applications where a failure would reasonably be expected to cause severe personal injury or death.

Copyright 2021 © Qorvo, Inc. | Qorvo is a registered trademark of Qorvo, Inc.

X-ON Electronics

Largest Supplier of Electrical and Electronic Components

Click to view similar products for [RF Development Tools](#) category:

Click to view products by [Qorvo](#) manufacturer:

Other Similar products are found below :

[MAAM-011117](#) [MAAP-015036-DIEEV2](#) [EV1HMC1113LP5](#) [EV1HMC6146BLC5A](#) [EV1HMC637ALP5](#) [EVAL-ADG919EBZ](#) [ADL5363-EVALZ](#) [LMV228SDEVAL](#) [SKYA21001-EVB](#) [SMP1331-085-EVB](#) [EV1HMC618ALP3](#) [EVAL01-HMC1041LC4](#) [MAAL-011111-000SMB](#)
[MAAM-009633-001SMB](#) [MASW-000936-001SMB](#) [107712-HMC369LP3](#) [107780-HMC322ALP4](#) [SP000416870](#) [EV1HMC470ALP3](#)
[EV1HMC520ALC4](#) [EV1HMC244AG16](#) [MAX2614EVKIT#](#) [124694-HMC742ALP5](#) [SC20ASATEA-8GB-STD](#) [MAX2837EVKIT+](#)
[MAX2612EVKIT#](#) [MAX2692EVKIT#](#) [EV1HMC629ALP4E](#) [SKY12343-364LF-EVB](#) [108703-HMC452QS16G](#) [EV1HMC863ALC4](#)
[EV1HMC427ALP3E](#) [119197-HMC658LP2](#) [EV1HMC647ALP6](#) [ADL5725-EVALZ](#) [106815-HMC441LM1](#) [EV1HMC1018ALP4](#)
[UXN14M9PE](#) [MAX2016EVKIT](#) [EV1HMC939ALP4](#) [MAX2410EVKIT](#) [MAX2204EVKIT+](#) [EV1HMC8073LP3D](#) [SIMSA868-DKL](#)
[SIMSA868C-DKL](#) [SKY65806-636EK1](#) [SKY68020-11EK1](#) [SKY67159-396EK1](#) [SKY66181-11-EK1](#) [SKY65804-696EK1](#)