

Product Description

The TQP9109 is a high efficiency two-stage driver amplifier in a low-cost surface-mount package. The amplifier is able to achieve high performance with +46 dBm OIP3 and +27.5 dBm P1dB while only consuming 245 mA current. The linear amplifier integrates two high performance amplifier stages onto a module to allow for a compact system design. The input is internally matched and the amplifier only requires minimal external components for operation. The integrated interstage match minimizes performance variation that would otherwise be attributed to external matching component value and placement tolerances.

The output stage amplifier is bias adjustable allowing the amplifier's power consumption to be reduced for occasions when the high power performance is not required. The output stage can also be turned off when not being used for power savings. The output match is tunable externally to allow the amplifier to be optimized for high power or high linearity applications. Up to 46 dBm OIP3 can be achieved when optimized for linearity. The TQP9109 is available in a RoHS-compliant 20-pin 4x4mm surface mount package.

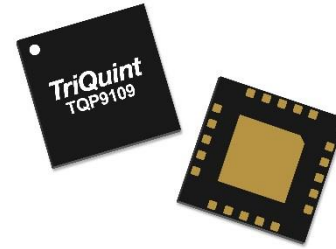

4x4 mm Leadless SMT Package

Key Features

- 1.7 – 2.7 GHz Frequency Range
- 30.5 dB gain
- +27.5 dBm P1dB
- +46 dBm Output IP3
- Input Internally Matched
- Integrated interstage matching
- Power down functionality for second stage amp
- Bias Adjustable

Functional Block Diagram

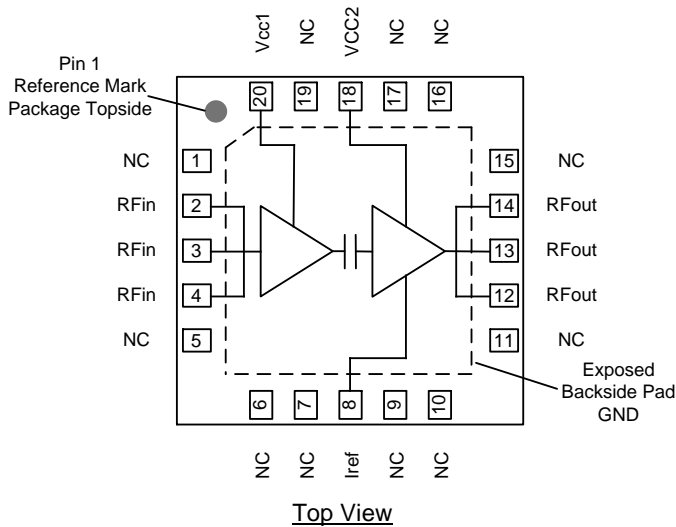

Applications

- Wireless Infrastructure
- Repeaters, Boosters, DAS
- High Power Amplifiers
- Pico and Macro Basestations

Ordering Information

Part No.	Description
TQP9109	2,500 pieces on a 13" reel (standard)
TQP9109-PCB2140	1.8 – 2.2 GHz Evaluation Board
TQP9109-PCB2600	2.3 – 2.7 GHz Evaluation Board

Absolute Maximum Ratings

Parameter	Rating
Storage Temperature	-50 to +150 °C
RF Input Power, CW, 50Ω, T=+25 °C	+8 dBm
Supply Voltage (V _{CC1} , V _{CC2})	+6 V

Exceeding any one or a combination of the Absolute Maximum Rating conditions may cause permanent damage to the device. Extended application of Absolute Maximum Rating conditions to the device may reduce device reliability.

Recommended Operating Conditions

Parameter	Min	Typ	Max	Units
Supply Voltage (V _{CC1} , V _{CC2})	+4.75	+5	+5.25	V
T _{CASE}	-40		+105	°C
T _j for >10 ⁶ hours MTTF			+170	°C

Electrical specifications are measured at specified test conditions. Specifications are not guaranteed over all recommended operating conditions.

Electrical Specifications

Test conditions unless otherwise noted: Supply Voltage = +5 V, I_{CQ} = 237 mA, I_{REF} = 8 mA, T_{CASE} = +25 °C

Parameter	Conditions	Min	Typ	Max	Units
Frequency Range		1700		2700	MHz
Test Frequency			2140		MHz
Gain		27.5	29.9	32.5	dB
Input Return Loss			11		dB
Output Return Loss			14		dB
Output P1dB		+25.0	+27.9		dBm
Output IP3	P _{out} = +11 dBm/tone, Δf=1 MHz	+41.0	+45.8		dBm
Noise Figure			3.5		dB
Total Current	I _{CQ1} + I _{CQ2} + I _{REF}	210	239	280	mA
Current, I _{CQ1}			89		mA
Current, I _{CQ2}			150		mA
Current, I _{REF}			8		mA
Thermal Resistance, θ _{jc}	Module (junction to case)			36.2	°C/W

Evaluation Board – TQP9109-PCB2140

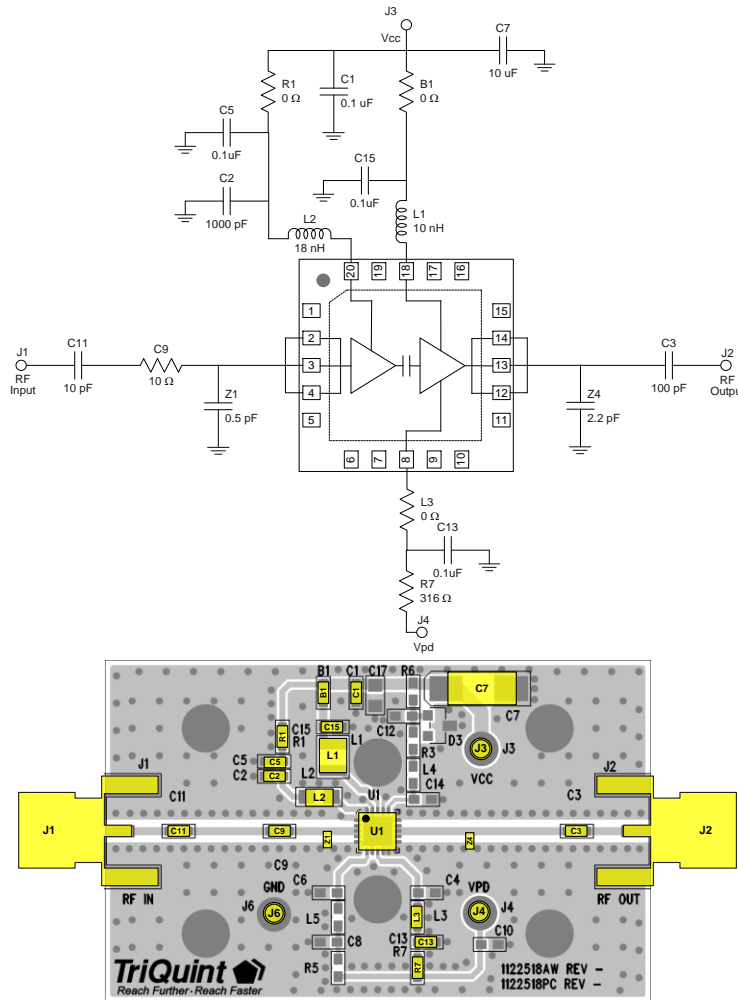

Bill of Material – TQP9109-PCB2140

Ref Des	Value	Description	Manuf.	Part Number
U1		AMP, 4x4mm SMT Module, 2-stage, Linear	Qorvo	TQP9109
C1, C5, C13, C15	0.1 uF	CAP, 0603,10%, 50V, X7R	various	
C2	1000 pF	CAP, 0603, 5%, 50V, NPO	various	
C3	100 pF	CAP, 0603, 5%, 50V, NPO	various	
Z1	0.5 pF	CAP, 0402, +/-0.1pF, 50V, NPO/COG	AVX	04025A0R5BAT2A
C9	10 Ω	RES, 0603, 1%, 1/16W, Chip	various	
Z4	2.2 pF	CAP, 0402, +/- 0.1pF. 50V, NPO	AVX	04025U2R2BAT2A
C7	10 uF	CAP, 6032, 20%, 50V, Tantalum	various	
C11	10 pF	CAP, 0603, +/-1%, 200V, NPO/COG	AVX	06032U100FAT2A
R7	316 Ω	RES, 0603	various	
B1, L3, R1	0 Ω	RES, 0603, 5%, 1/16W, Chip	various	
L1	10 nH	IND, 1008, 5%, Ceramic	Coilcraft	1008CS-100XJL
L2	18 nH	IND, 0805, 5%, Ceramic	Coilcraft	0805CS-180XJL

Typical Performance – TQP9109-PCB2140

Test conditions unless otherwise noted: $V_{CC} = +5\text{ V}$, $I_{TOTAL} = 245\text{ mA (typ.)}$, $V_{pd} = +5\text{ V}$, $Temp. = +25\text{ }^{\circ}\text{C}$

Parameter	Conditions	Typical Value			Units
Frequency		1800	1960	2140	MHz
Gain		30.4	31.0	30.5	dB
Input Return Loss		12	12	12	dB
Output Return Loss		16	20	14	dB
Output P1dB		+28.5	+28.2	+27.5	dBm
OIP3	$P_{out} = +11\text{ dBm/tone}$, $\Delta f = 1\text{ MHz}$	+42	+42.5	+46	dBm
Noise Figure		3.5	3.5	3.5	dB

Performance Plots – TQP9109-PCB2140

Test conditions unless otherwise noted: $V_{CC} = +5\text{ V}$, $I_{TOTAL} = 245\text{ mA (typ.)}$, $Temp. = +25\text{ }^{\circ}\text{C}$

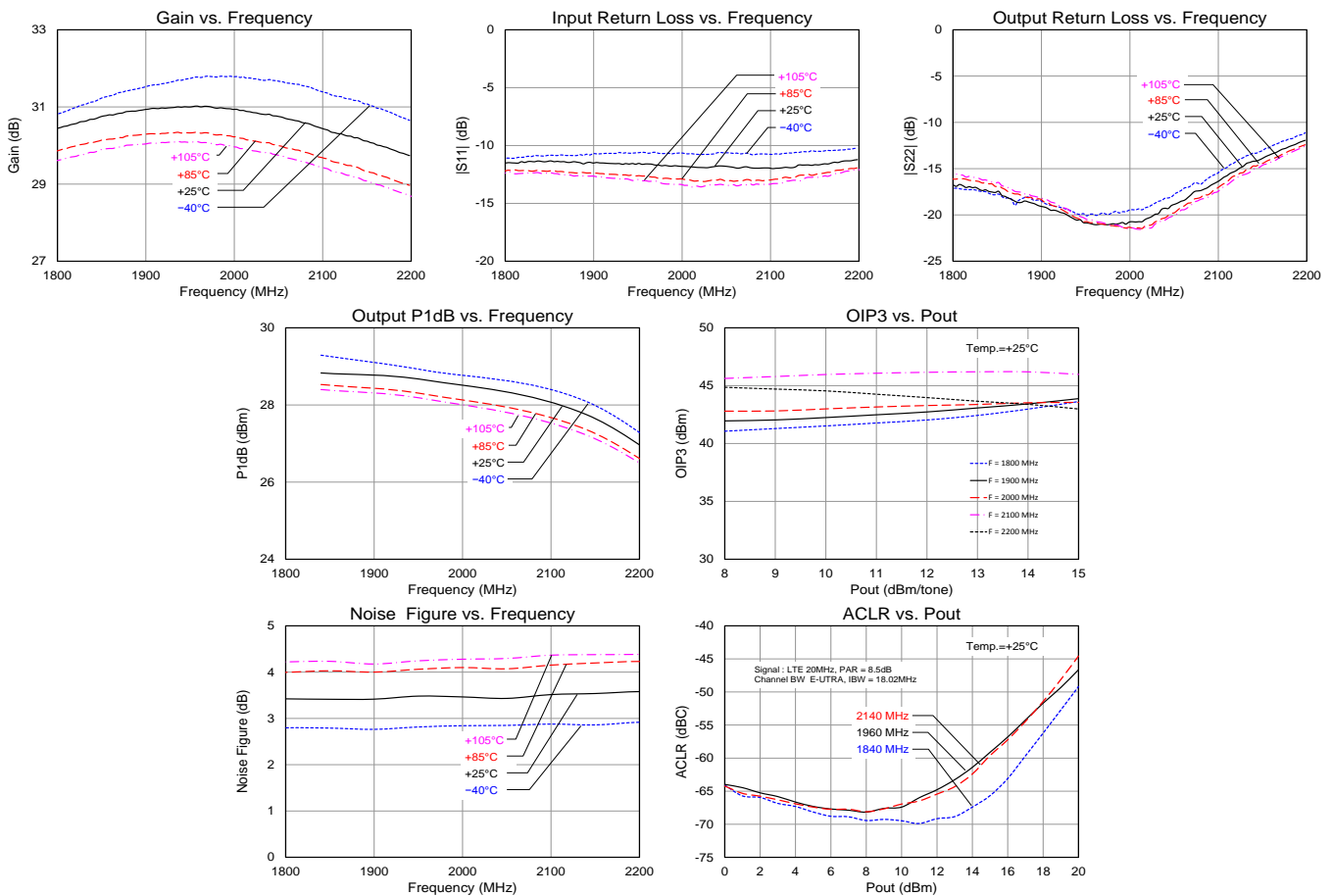

Evaluation Board – TQP9109-PCB2600

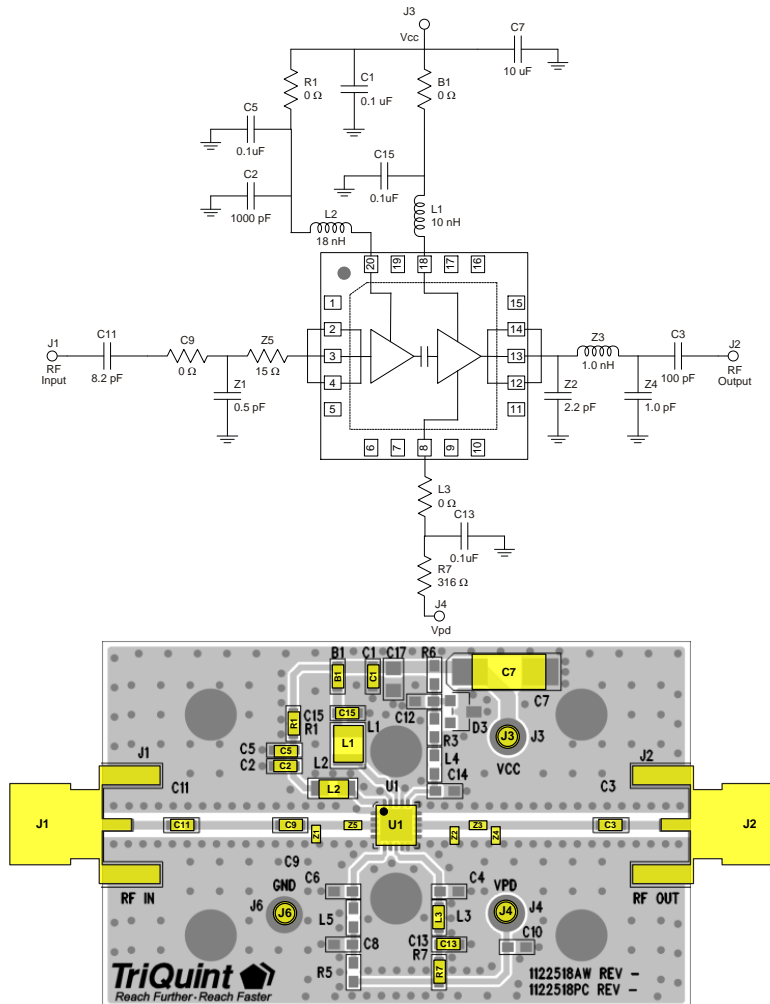

Bill of Material – TQP9109-PCB2600

Ref Des	Value	Description	Manuf.	Part Number
U1		AMP, 4x4mm SMT Module, 2-stage, Linear	Qorvo	TQP9109
C1, C5, C13, C15	0.1 uF	CAP, 0603,10%, 50V, X7R	various	
C2	1000 pF	CAP, 0603, 5%, 50V, NPO	various	
C3	100 pF	CAP, 0603, 5%, 50V, NPO	various	
Z1	0.5 pF	CAP, 0402, +/-0.1pF, 50V, NPO/COG	AVX	04025A0R5BAT2A
Z5	15 Ω	RES, 0402, 5%, 1/16W, Chip	various	
Z2	2.2 pF	CAP, 0402, +/- 0.1pF, 50V, NPO	AVX	04025U2R2BAT2A
Z3	1 nH	IND, 0402, +/-0.3 nH	TOKO	LL1005-FHL1NOS
C7	10 uF	CAP, 6032, 20%, 50V, Tantalum	various	
Z4	1 pF	CAP, 0402, +/- 0.1pF, 50V, NPO/COG	AVX	04025A1R0BAT2A
C11	8.2 pF	CAP, 0603, +/-0.1pF, 200V, NPO/COG	AVX	06032U8R2BAT2A
R7	316 Ω	RES, 0603	various	
B1, L3, R1, C9	0 Ω	RES, 0603, 5%, 1/16W, Chip	various	
L1	10 nH	IND, 1008, 5%, Ceramic	Coilcraft	1008CS-100XJL
L2	18 nH	IND, 0805, 5%, Ceramic	Coilcraft	0805CS-180XJL

Typical Performance – TQP9109-PCB2600

Test conditions unless otherwise noted: $V_{CC} = +5\text{ V}$, $I_{TOTAL} = 245\text{ mA}$ (typ.), $V_{pd} = +5\text{ V}$, Temp. = $+25\text{ }^{\circ}\text{C}$

Parameter	Conditions	Typical Value			Units
Frequency		2300	2500	2700	MHz
Gain		30.3	29.9	30.0	dB
Input Return Loss		11	17	14	dB
Output Return Loss		18	12	5.7	dB
Output P1dB		+28.0	+27.6	+27.3	dBm
OIP3	$P_{out} = +11\text{ dBm/tone}$, $\Delta f = 1\text{ MHz}$	+44	+42.5	+44	dBm
Noise Figure		4.0	4.0	4.1	dB

Performance Plots – TQP9109-PCB2600

Test conditions unless otherwise noted: $V_{CC} = +5\text{ V}$, $I_{CQ} = 245\text{ mA}$ (typ.), Temp. = $+25\text{ }^{\circ}\text{C}$

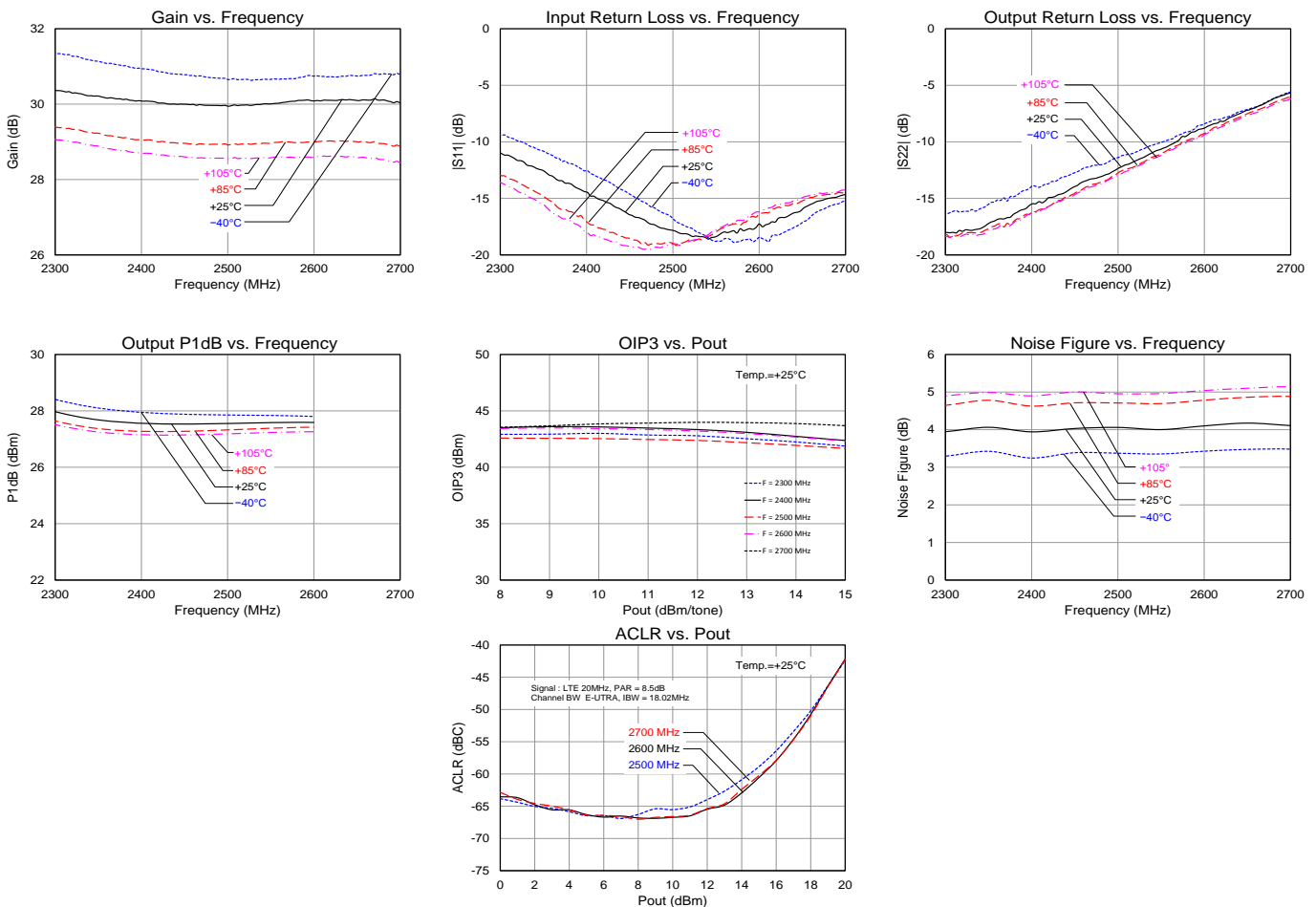

Evaluation Board – TQP9109 – 1700 to 2700 MHz

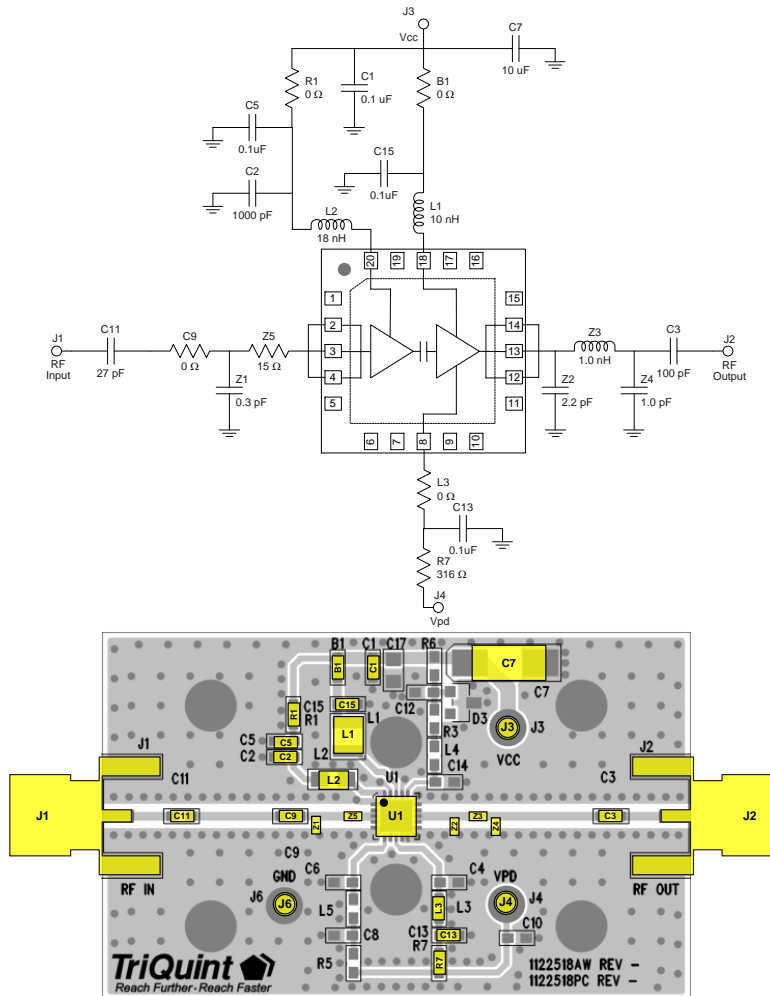

Bill of Material – TQP9109 – 1700 to 2700 MHz

Ref Des	Value	Description	Manuf.	Part Number
U1		AMP, 4x4mm SMT Module, 2-stage, Linear	Qorvo	TQP9109
C1, C5, C13, C15	0.1 uF	CAP, 0603,10%, 50V, X7R	various	
C2	1000 pF	CAP, 0603, 5%, 50V, NPO	various	
C3	100 pF	CAP, 0603, 5%, 50V, NPO	various	
Z1	0.3 pF	CAP, 0402, +/-0.1PF. 50V. NPO/COG	various	
Z5	15 Ω	RES, 0402, 5PCT. 1/16W. CHIP.	various	
Z2	2.2 pF	CAP, 0402, +/- 0.1PF. 50V. NPO	AVX	04025U2R2BAT2A
Z3	1 nH	IND, 0402, chip, +/-0.3 nH	TOKO	LL1005-FHL1NOS
C7	10 uF	CAP, 6032, 20%, 50V, Tantalum	various	
Z4	1 pF	CAP, 0402, +/- 0.1PF. 50V. NPO/COG	AVX	04025A1R0BAT2A
C11	27 pF	CAP, 0603, +/-0.1PF. 200V. NPO/COG	various	
R7	316 Ω	RES, 0603	various	
B1, L3, R1, C9	0 Ω	RES, 0603, 5%, 1/16W, Chip	various	
L1	10 nH	IND, 1008, 5%, Ceramic	Coilcraft	1008CS-100XJL
L2	18 nH	IND, 0805, 5%, Ceramic	Coilcraft	0805CS-180XJL

Typical Performance – TQP9109 – 1700 to 2700 MHz

Test conditions unless otherwise noted: $V_{CC} = +5\text{ V}$, $I_{TOTAL} = 245\text{ mA (typ.)}$, $V_{pd} = +5\text{ V}$, $Temp. = +25\text{ }^{\circ}\text{C}$

Parameter	Conditions	Typical Value			Units
Frequency		1700	2200	2700	MHz
Gain		28.0	29.7	29.6	dB
Input Return Loss		16	11	16	dB
Output Return Loss		11	15	7.3	dB
Output P1dB		+30.2	+29.9	+27.9	dBm
OIP3	$P_{out} = +16\text{ dBm/tone}$, $\Delta f = 1\text{ MHz}$	+40	+40.5	+41.6	dBm

Performance Plots – TQP9109 – 1700 to 2700 MHz

Test conditions unless otherwise noted: $V_{CC} = +5\text{ V}$, $I_{CQ} = 245\text{ mA (typ.)}$, $Temp. = +25\text{ }^{\circ}\text{C}$

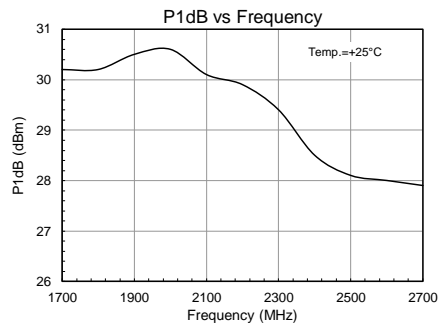
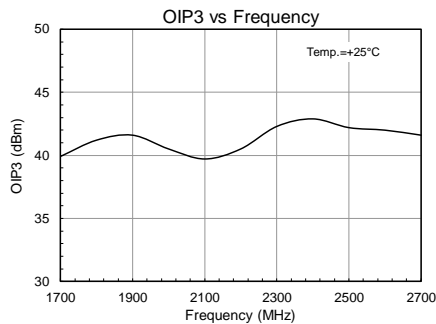
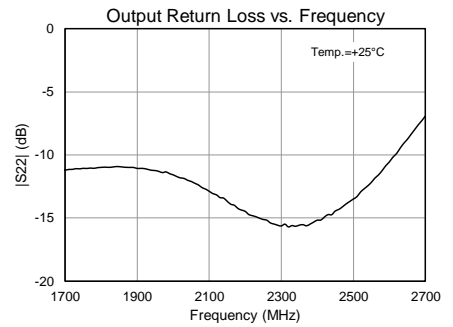
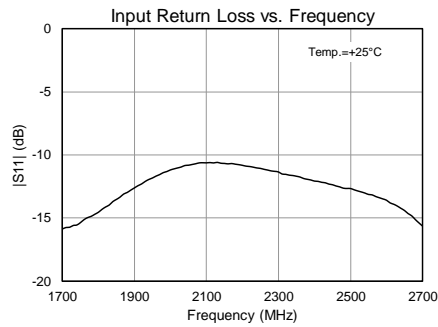
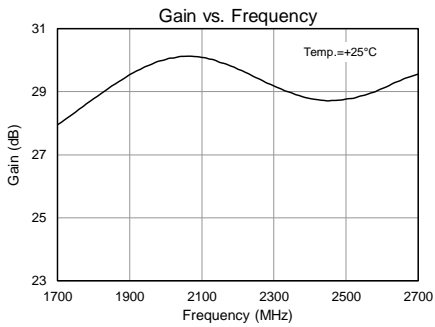

Pin Configuration and Description

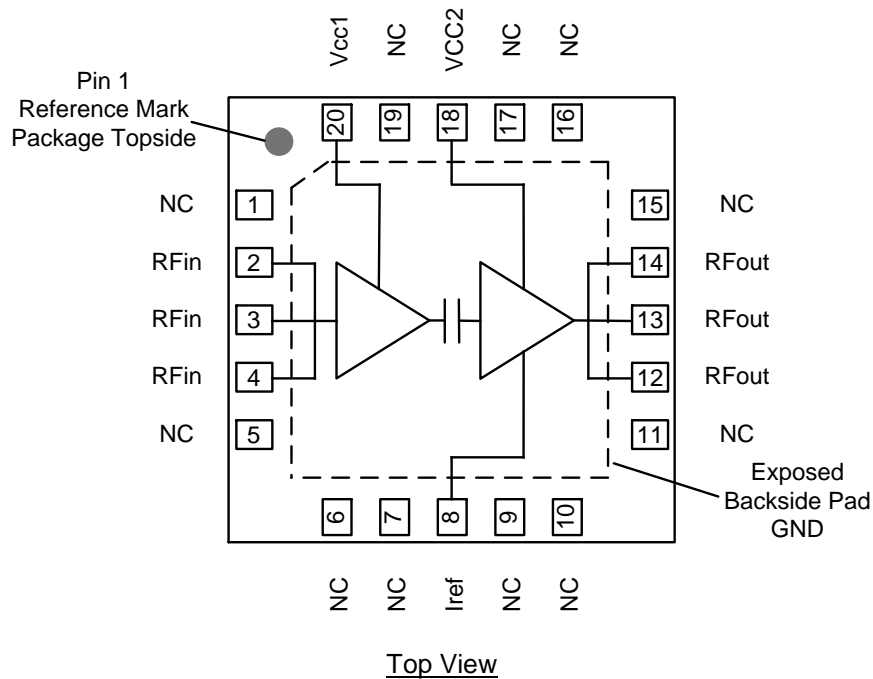

Pin No.	Label	Description
2, 3, 4	RF Input	RF Input pins. Requires DC blocking.
8	I _{REF}	Sets the bias current for Amp2. Also can be used to power down.
12, 13, 14	RF Output	RF output pins. Require DC blocking and RF match for optimal performance.
18	V _{CC2}	2 nd Stage DC voltage supply connection.
20	V _{CC1}	1 st Stage DC voltage supply connection.
1, 5, 6, 7, 9, 10, 11, 15, 16, 17, 19	N/C	No internal connection. Provide grounded land pads for PCB mounting integrity.
Backside Pad	GND	RF/DC ground. Use recommended via hole pattern to minimize inductance and thermal resistance; see PCB Mounting Pattern for suggested footprint.

Package Marking and Dimensions

Marking: Part number – TQP9109
 Date - YYWW
 Lot code – AaXXXX

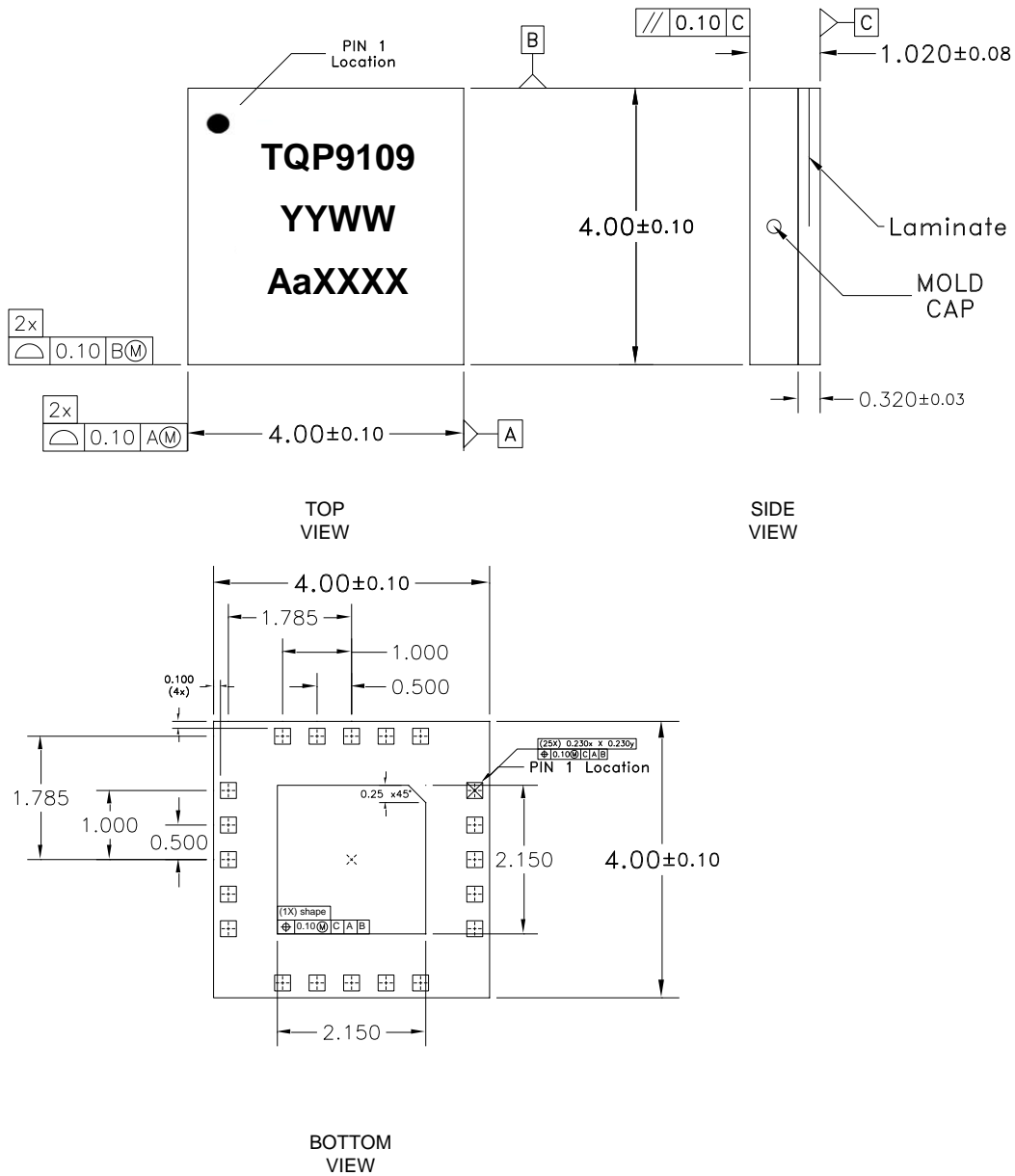

Notes:

1. All dimensions are in millimeters. Angles are in degrees.
2. Dimension and tolerance formats conform to ASME Y14.4M-1994.
3. The terminal #1 identifier and terminal numbering conform to JESD 95-1 SPP-012.

Handling Precautions

Parameter	Rating	Standard
ESD – Human Body Model (HBM)	Class 1B	ESDA / JEDEC JS-001-2012
ESD – Charged Device Model (CDM)	Class C3	JEDEC JESD22-C101F
MSL – Moisture Sensitivity Level	Level 3	IPC/JEDEC J-STD-020



Caution!
ESD-Sensitive Device

Solderability

Compatible with both lead-free (260°C max. reflow temp.) and tin/lead (245°C max. reflow temp.) soldering processes. Solder profiles available upon request.

Contact plating: Electrolytic plated Au over Ni

RoHS Compliance

This part is compliant with 2011/65/EU RoHS directive (Restrictions on the Use of Certain Hazardous Substances in Electrical and Electronic Equipment) as amended by Directive 2015/863/EU. This product also has the following attributes:

- Product uses RoHS Exemption 7c-I to meet RoHS Compliance requirements
- Halogen Free (Chlorine, Bromine)
- Antimony Free
- TBBP-A (C₁₅H₁₂Br₄O₂) Free
- PFOS Free
- SVHC Free

Contact Information

For the latest specifications, additional product information, worldwide sales and distribution locations:

Web: www.qorvo.com

Tel: 1-844-890-8163

Email: customer.support@qorvo.com

For technical questions and application information:

Email: appsupport@qorvo.com

Important Notice

The information contained herein is believed to be reliable; however, Qorvo makes no warranties regarding the information contained herein and assumes no responsibility or liability whatsoever for the use of the information contained herein. All information contained herein is subject to change without notice. Customers should obtain and verify the latest relevant information before placing orders for Qorvo products. The information contained herein or any use of such information does not grant, explicitly or implicitly, to any party any patent rights, licenses, or any other intellectual property rights, whether with regard to such information itself or anything described by such information. **THIS INFORMATION DOES NOT CONSTITUTE A WARRANTY WITH RESPECT TO THE PRODUCTS DESCRIBED HEREIN, AND QORVO HEREBY DISCLAIMS ANY AND ALL WARRANTIES WITH RESPECT TO SUCH PRODUCTS WHETHER EXPRESS OR IMPLIED BY LAW, COURSE OF DEALING, COURSE OF PERFORMANCE, USAGE OF TRADE OR OTHERWISE, INCLUDING THE IMPLIED WARRANTIES OF MERCHANTABILITY AND FITNESS FOR A PARTICULAR PURPOSE.**

Without limiting the generality of the foregoing, Qorvo products are not warranted or authorized for use as critical components in medical, life-saving, or life-sustaining applications, or other applications where a failure would reasonably be expected to cause severe personal injury or death.

Copyright 2018 © Qorvo, Inc. | Qorvo is a registered trademark of Qorvo, Inc.

X-ON Electronics

Largest Supplier of Electrical and Electronic Components

Click to view similar products for [RF Amplifier](#) category:

Click to view products by [Qorvo](#) manufacturer:

Other Similar products are found below :

[A82-1](#) [BGA622H6820XTSA1](#) [BGA 728L7 E6327](#) [BGB719N7ESDE6327XTMA1](#) [HMC397-SX](#) [HMC405](#) [HMC561-SX](#) [HMC8120-SX](#)
[HMC8121-SX](#) [HMC-ALH382-SX](#) [HMC-ALH476-SX](#) [SE2433T-R](#) [SMA3101-TL-E](#) [SMA39](#) [A66-1](#) [A66-3](#) [A67-1](#) [LX5535LQ](#) [LX5540LL](#)
[MAAM02350](#) [HMC3653LP3BETR](#) [HMC549MS8GETR](#) [HMC-ALH435-SX](#) [SMA101](#) [SMA32](#) [SMA411](#) [SMA531](#) [SST12LP19E-QX6E](#)
[WPM0510A](#) [HMC5929LS6TR](#) [HMC5879LS7TR](#) [HMC1126](#) [HMC1087F10](#) [HMC1086](#) [HMC1016](#) [SMA1212](#) [MAX2689EWS+T](#)
[MAAMSS0041TR](#) [MAAM37000-A1G](#) [LTC6430AIUF-15#PBF](#) [CHA5115-QDG](#) [SMA70-2](#) [SMA4011](#) [A231](#) [HMC-AUH232](#) [LX5511LQ](#)
[LX5511LQ-TR](#) [HMC7441-SX](#) [HMC-ALH310](#) [XD1001-BD-000V](#)