

General Description

The TQP9326 is a high-efficiency three-stage power amplifier in a low-cost surface-mount package with on-chip bias control and temperature control circuits, suitable for small cell base station applications.

TQP9326 provides 34 dB gain and +27 dBm linear power with linearization correction over the 2.5–2.7 GHz frequency range for Bands 7, 40, and 41. With pre-distortion, the amplifier is able to achieve –50 dBc ACLR at +27 dBm output power using 20 MHz LTE signal.

The TQP9326 integrates three high performance amplifier stages onto a module to allow for a compact system design and requires very few external components for operation. The amplifier is bias adjustable allowing the amplifier’s power consumption to be optimized. The TQP9326 is available in a lead-free/RoHS-compliant 3.5 x 4.5 mm surface mount package.

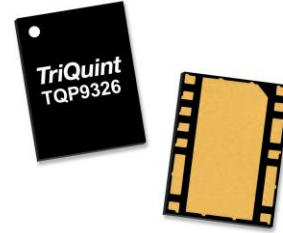

3.5 x 4.5 mm Leadless SMT Package

Product Features

- 2.3 – 2.7 GHz Frequency Range
- Fully integrated, 3 Stage Power Amplifier
- Internally matched 50 Ω input/output
- –50 dBc ACLR at +27 dBm Pavg (with correction)
- 34 dB Gain
- 22% PAE at +27 dBm
- 115 mA Quiescent Current
- In-built Control Bias and Temp. Comp Circuit
- Single Supply Voltage: +5 V
- Lead-free / RoHS compliant
- POE Capable

Functional Block Diagram

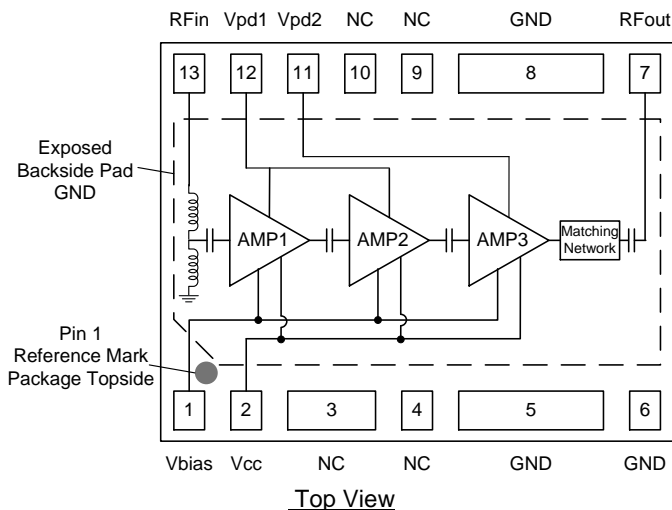

Applications

- Small-Cell / Pico-Cell
- Enterprise Femtocell
- Bands 7, 40, 41

Ordering Information

Part No.	Description
TQP9326	High Efficiency 0.5 W Small Cell PA
TQP9326-PCB	2.5 – 2.7 GHz Evaluation board



Absolute Maximum Ratings

Parameter	Rating
Storage Temperature	-55 to +150 °C
Supply Voltage (V _{CC})	+6 V
RF Input Power, CW, 50Ω, T=25°C	+10 dBm

Exceeding any one or a combination of the Absolute Maximum Rating conditions may cause permanent damage to the device. Extended application of Absolute Maximum Rating conditions to the device may reduce device reliability.

Recommended Operating Conditions

Parameter	Min	Typ	Max	Units
V _{DD}	+4.75	+5	+5.25	V
T _{CASE}	-40	+25	+85	°C
T _j for >10 ⁶ hours MTTF			+175	°C

Notes: Electrical specifications are measured at specified test conditions. Specifications are not guaranteed over all recommended operating conditions.

Electrical Specifications

Test conditions unless otherwise noted: V_{CC} = +5V, V_{pd} = +5V, Temp = +25°C.

Parameter	Conditions	Min	Typ	Max	Units
Operational Frequency Range		2300		2700	MHz
Output Channel Power			+27		dBm
Gain	2500 – 2700 MHz		34		dB
ACLR Uncorrected	See note 1		-35		dBc
ACLR Corrected	See note 1		-48		dBc
Power Added Efficiency	See note 1		22		%
Noise Figure			4.0		dB
Output P3dB	2500-2700 MHz		+35		dBm
Supply Voltage			5		V
Quiescent Current, I _{CQ}			115		mA
Reference Current, I _{pd}			2		mA
Operational Current, I _{CC}	P _{out} = +27 dBm		454		mA
VSWR Survivability	P _{out} = +26 dBm, 2.5 – 2.7 GHz Signal : WCDMA 1C, PAR = 8dB	7:1			
Thermal Resistance, θ _{Jc}	Module (junction to case)		27		°C/W

Notes:

- Using LTE signal, 20 MHz/Carrier, IBW = 18.02 MHz, PAR 7.5 dB, P_{out} = +27 dBm

Performance Plots

Test conditions unless otherwise noted: $V_{CC} = +5V$, $V_{PD1} = V_{PD2} = +5V$, Temp. = $+25^{\circ}C$.

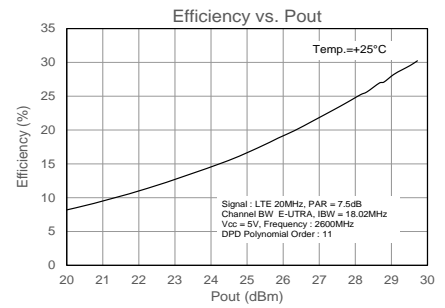
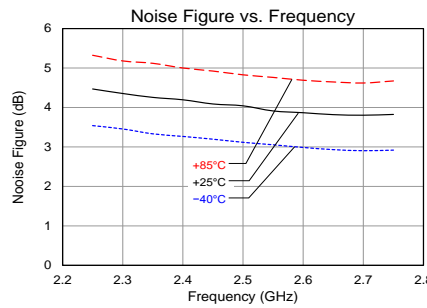
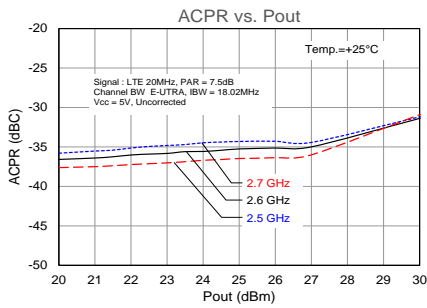
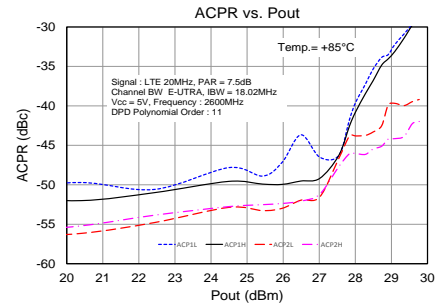
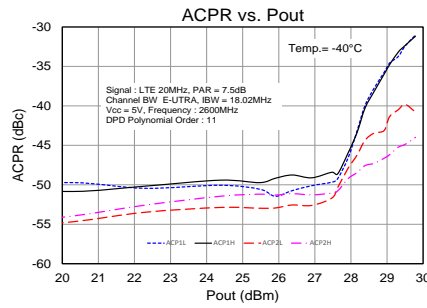
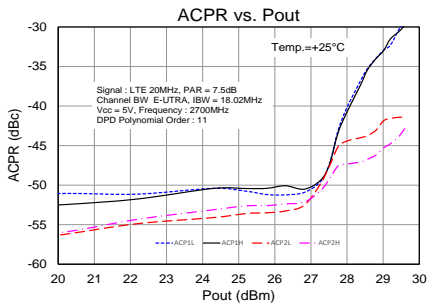
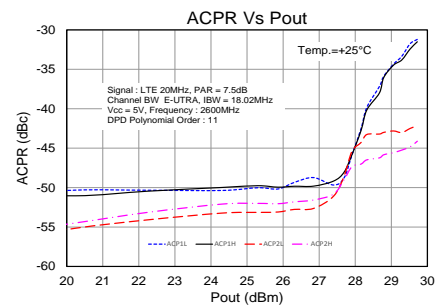
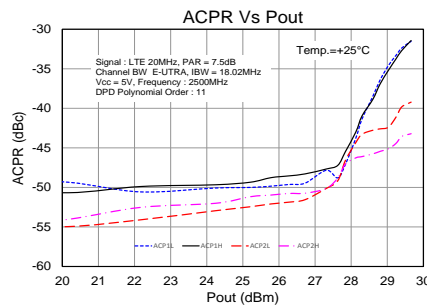
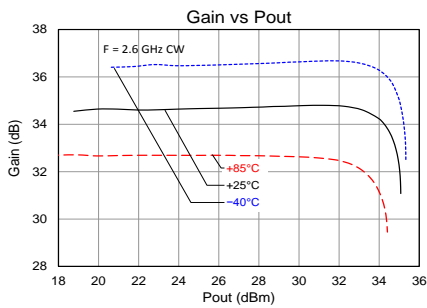
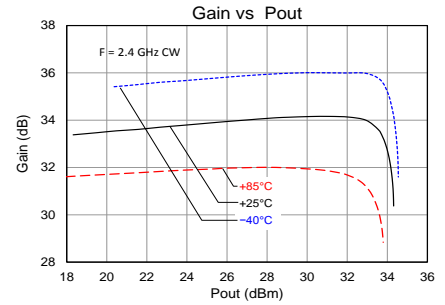
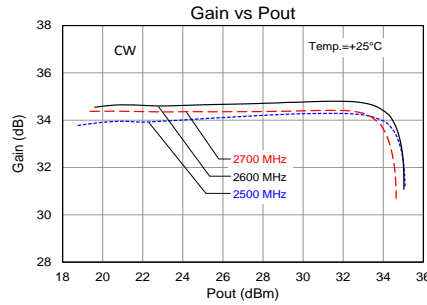
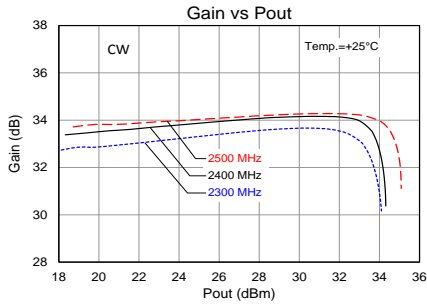

Application Circuit

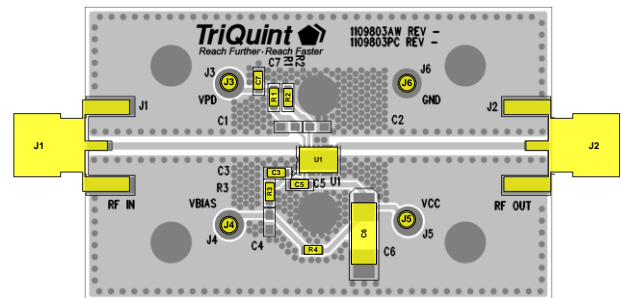
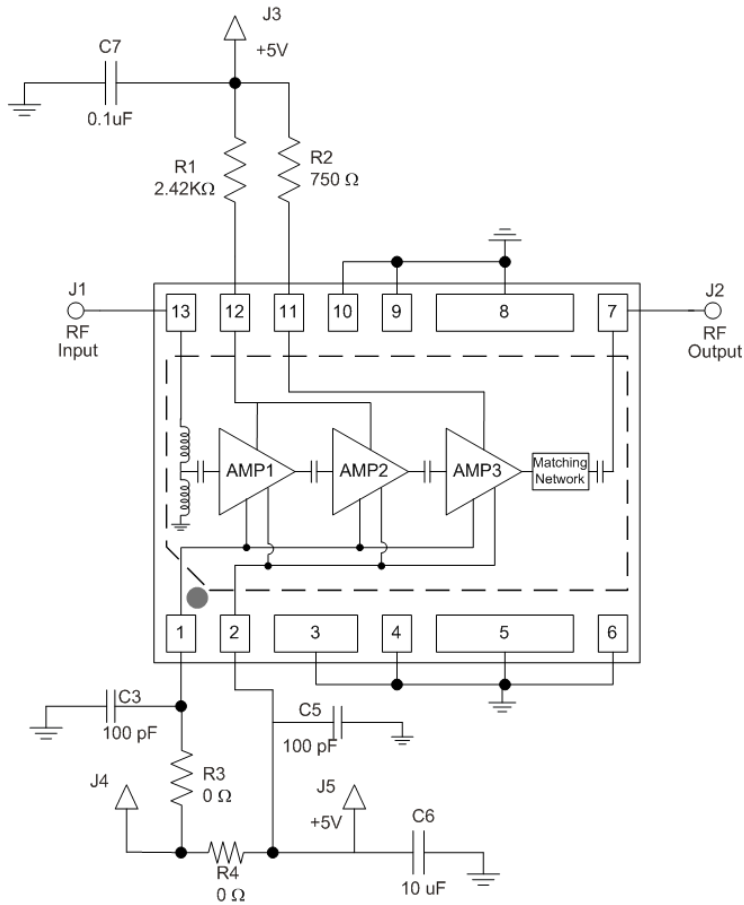

Bill of Material

Ref Des	Value	Description	Manuf.	Part Number
n/a	n/a	Printed Circuit Board		
U1	n/a	High Efficiency 3-stage PA	TriQuint	TQP9326
R4	0 Ω	Resistor, Chip, 0603, 5%	various	
R3	0 Ω	Resistor, Chip, 0603, 1%	various	
C7	0.1 uF	Capacitor, Chip, 0603, 5%	various	
C6	10 uF	Capacitor, Chip, 6032, 10%, Tantalum	various	
C3, C5	100 pF	Capacitor, Chip, 0603, NPO/COG, 5%	various	
R2	750 Ω	Resistor, Chip, 0603, 5%, 1/16W	various	
R1	2.42 KΩ	Resistor, Chip, 0603, 5%, 1/16W	various	
C1, C2, C4		Do Not Place		

2.3 – 2.4 GHz Application Circuit

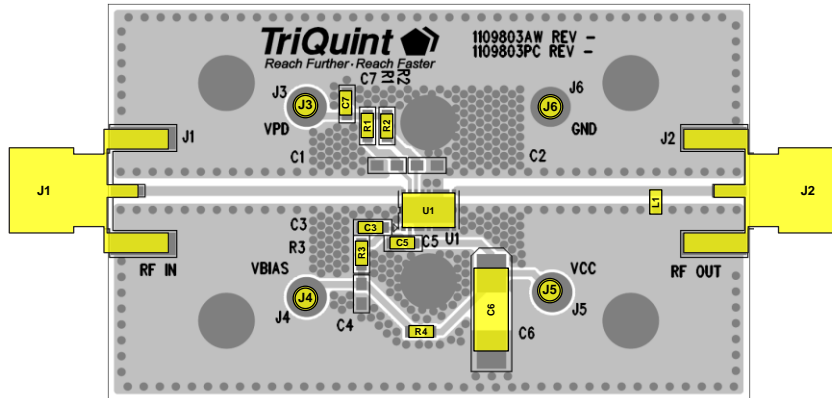

Notes:

1. See Evaluation Board PCB Information section for PCB material and stack-up
2. All components are of 0603 size unless otherwise specified.
3. Critical component placement locations:
Distance from U1 Package (right edge) to L1 (left edge): 620 mils

Bill of Material (2.3 – 2.4 GHz Reference Design)

Ref Des	Value	Description	Manuf.	Part Number
n/a	n/a	Printed Circuit Board		
U1	n/a	High Efficiency 3-stage PA	TriQuint	TQP9326
R4	0 Ω	Resistor, Chip, 0603, 5%	various	
R3	0 Ω	Resistor, Chip, 0603, 1%	various	
C7	0.1 uF	Capacitor, Chip, 0603, 5%	various	
C6	10 uF	Capacitor, Chip, 6032, 10%, Tantalum	various	
C3, C5	100 pF	Capacitor, Chip, 0603, NPO/COG, 5%	various	
R2	750 Ω	Resistor, Chip, 0603, 5%, 1/16W	various	
R1	2.42 KΩ	Resistor, Chip, 0603, 5%, 1/16W	various	
L1	3.3 nH	Inductor, Chip, 0603, 5%	various	
C1, C2, C4		Do Not Place		

Performance Plots (2.3 – 2.4 GHz Reference Design)

Test conditions unless otherwise noted: $V_{CC} = +5V$, $V_{PD1} = V_{PD2} = +5V$, Temp. = +25°C.

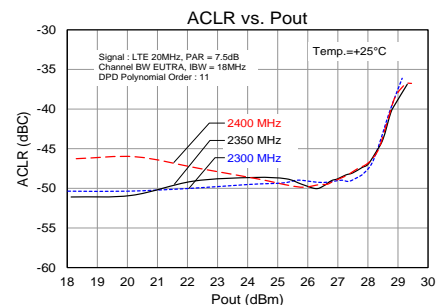
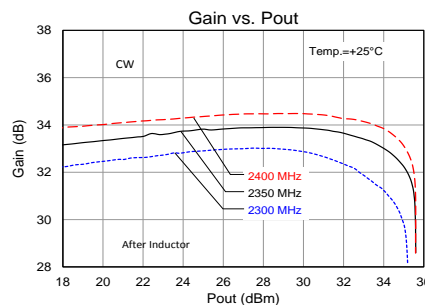
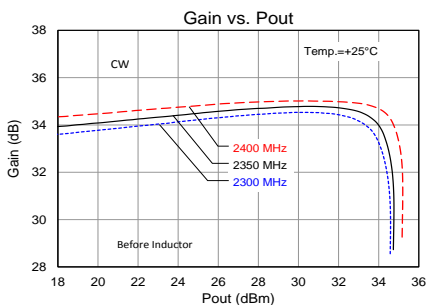

Pin Configuration and Description

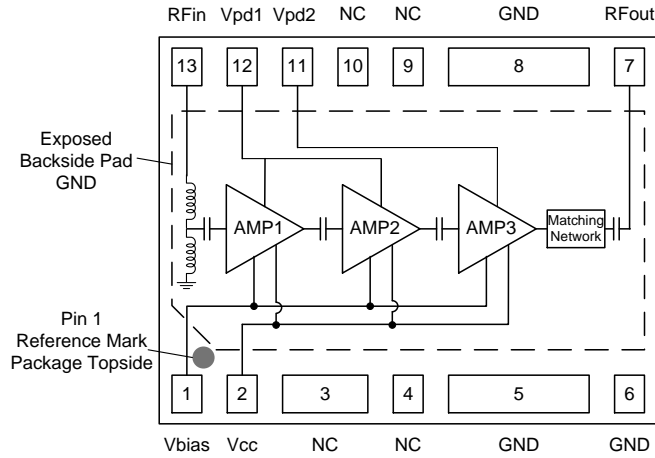

Pin No.	Label	Description
1	Vbias	Provides reference voltage for internal active biasing circuit
2	Vcc	DC voltage supply connection
3, 4, 9, 10	NC	No internal connection. Provide grounded land pads for PCB mounting integrity (Pins 5, 6, and 8 are internally grounded).
5, 6, 8	GND	Pins 5, 6, and 8 are internally grounded.
7	RFout	RF output pin. The DC is internally blocked at this pin.
11	Vpd2	Power down for Amp 1. This voltage adjusts for the current draw in Amp 1.
12	Vpd1	Power down for Amp 2. This voltage adjusts for the current draw in Amp 2.
13	RFin	RF input pin. Any external DC needs to be blocked from this pin.
Backside Paddle	RF/DC GND	RF/DC ground. Use recommended via pattern to minimize inductance and thermal resistance; see PCB Mounting Pattern for suggested footprint.

Evaluation Board PCB Information

TriQuint PCB 1100415 Material and Stack-up

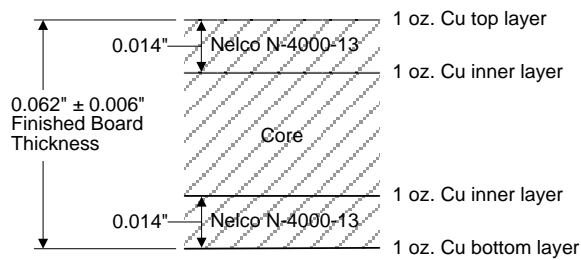

50 ohm line dimensions: width = .028"
spacing = .028".

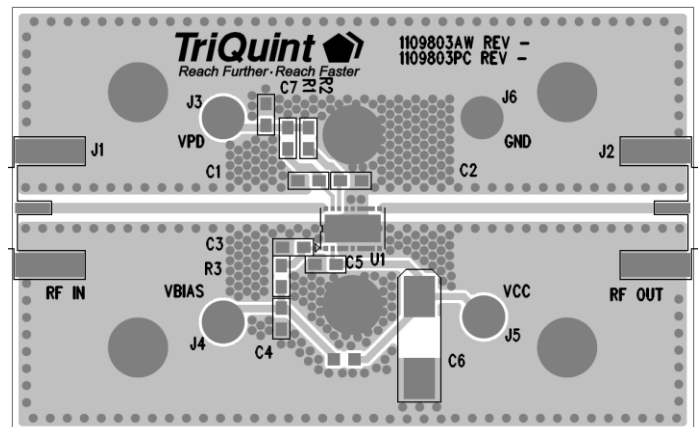

Mechanical Information

Package Marking and Dimensions

Marking: Part number – 9326
 Assembly Code - YYWW
 Lot code –aaXXXX

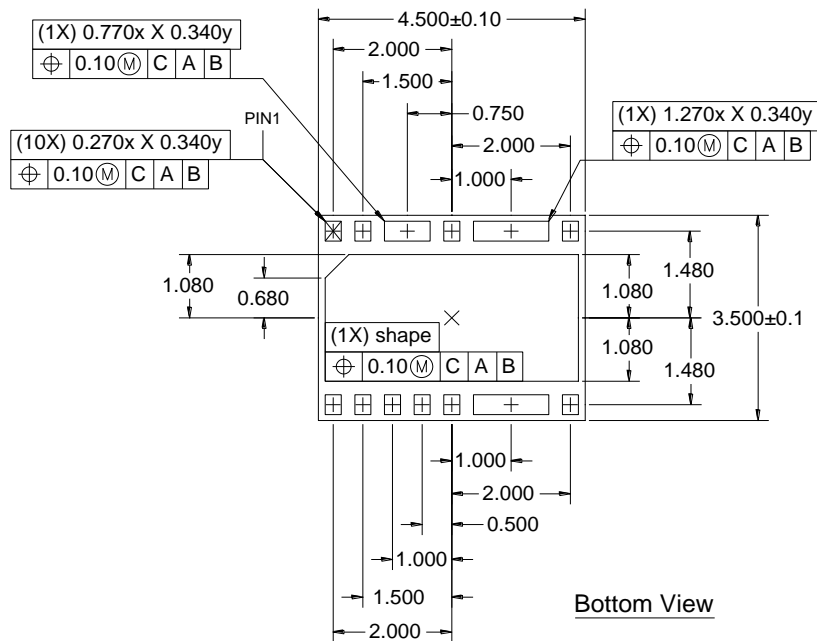
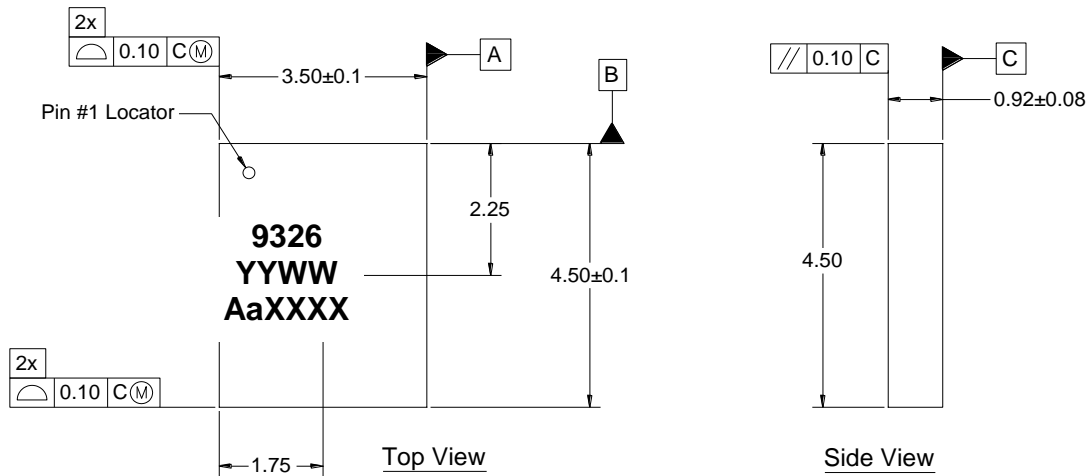

Notes:

1. All dimensions are in millimeters. Angles are in degrees.
2. Except where noted, this part outline conforms to JEDEC standard MO-229.
3. Dimension and tolerance formats conform to ASME Y14.4M-1994.
4. The terminal #1 identifier and terminal numbering conform to JESD 95-1 SPP-012.

PCB Mounting Pattern

Recommend PCB land-pad pattern metallization (Top View)

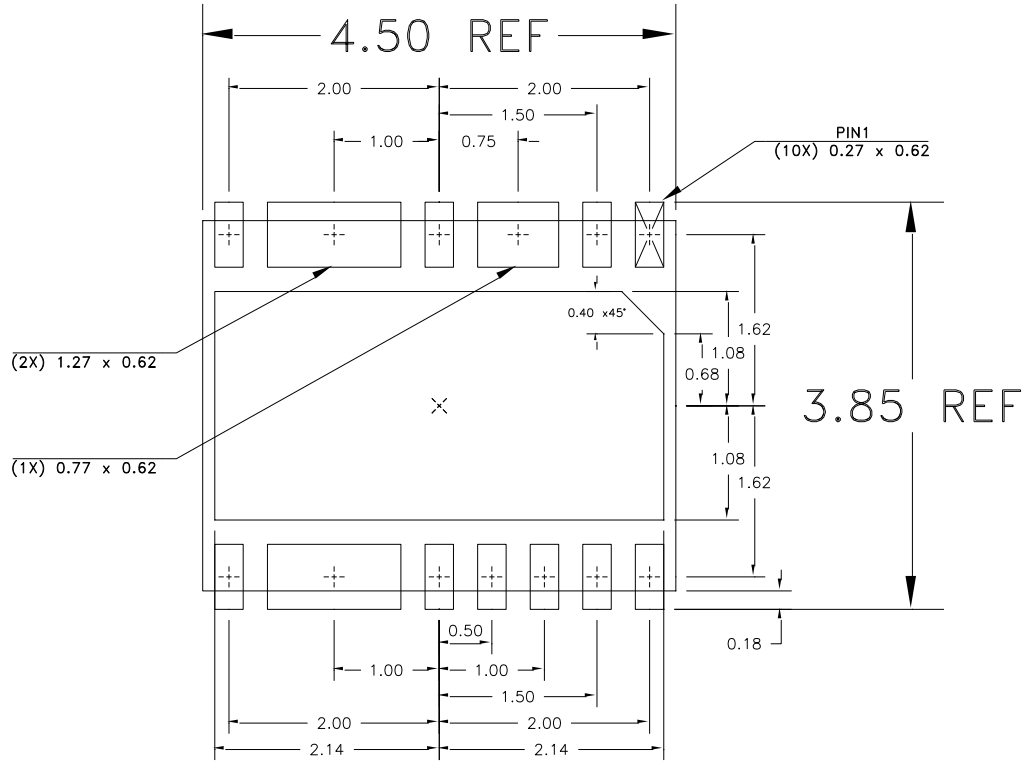

Recommended PCB solder mask opening (Top View)

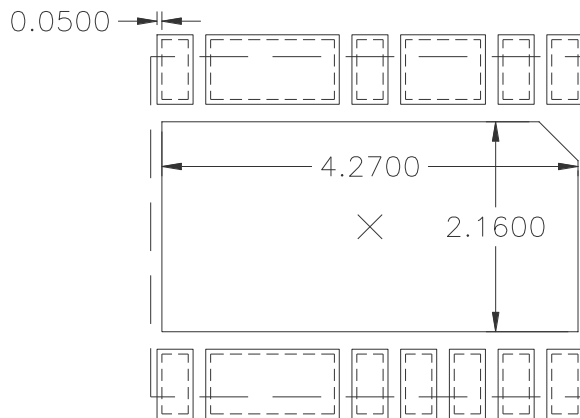

Notes:

1. A heat sink underneath the area of the PCB for the mounted device is strictly required for proper thermal operation. Damage to the device can occur without the use of one.
2. Ground / thermal vias are critical for the proper performance of this device. Vias should use a .35mm (#80 / .0135") diameter drill and have a final plated thru diameter of .25 mm (.010").
3. Add as much copper as possible to inner and outer layers near the part to ensure optimal thermal performance.

Handling Precautions

Parameter	Rating	Standard
ESD – Human Body Model (HBM)	Class 1C	ESDA / JEDEC JS-001-2012
ESD – Charged Device Model (CDM)	Class C3	JEDEC JESD22-C101F
MSL – Moisture Sensitivity Level	Level 3	IPC/JEDEC J-STD-020



Caution!
ESD-Sensitive Device

Solderability

Compatible with both lead-free (260°C max. reflow temp.) and tin/lead (245°C max. reflow temp.) soldering processes.
Solder profiles available upon request.
Contact plating: Electrolytic plated Au over Ni

RoHS Compliance

This part is compliant with EU 2002/95/EC RoHS directive (Restrictions on the Use of Certain Hazardous Substances in Electrical and Electronic Equipment). This product also has the following attributes:

- Product uses RoHS Exemption 7c-I to meet RoHS Compliance requirements
- Halogen Free (Chlorine, Bromine)
- Antimony Free
- TBBP-A (C₁₅H₁₂Br₄O₂) Free
- PFOS Free
- SVHC Free
- Qorvo Green



Contact Information

For the latest specifications, additional product information, worldwide sales and distribution locations:

Tel: 1-844-890-8163

Web: www.qorvo.com

Email: customer.support@qorvo.com

For technical questions and application information: **Email:** appsupport@qorvo.com

Important Notice

The information contained herein is believed to be reliable; however, Qorvo makes no warranties regarding the information contained herein and assumes no responsibility or liability whatsoever for the use of the information contained herein. All information contained herein is subject to change without notice. Customers should obtain and verify the latest relevant information before placing orders for Qorvo products. The information contained herein or any use of such information does not grant, explicitly or implicitly, to any party any patent rights, licenses, or any other intellectual property rights, whether with regard to such information itself or anything described by such information. **THIS INFORMATION DOES NOT CONSTITUTE A WARRANTY WITH RESPECT TO THE PRODUCTS DESCRIBED HEREIN, AND QORVO HEREBY DISCLAIMS ANY AND ALL WARRANTIES WITH RESPECT TO SUCH PRODUCTS WHETHER EXPRESS OR IMPLIED BY LAW, COURSE OF DEALING, COURSE OF PERFORMANCE, USAGE OF TRADE OR OTHERWISE, INCLUDING THE IMPLIED WARRANTIES OF MERCHANTABILITY AND FITNESS FOR A PARTICULAR PURPOSE.**

Without limiting the generality of the foregoing, Qorvo products are not warranted or authorized for use as critical components in medical, life-saving, or life-sustaining applications, or other applications where a failure would reasonably be expected to cause severe personal injury or death.

Copyright 2017 © Qorvo, Inc. | Qorvo is a registered trademark of Qorvo, Inc.

X-ON Electronics

Largest Supplier of Electrical and Electronic Components

Click to view similar products for [RF Amplifier](#) category:

Click to view products by [Qorvo](#) manufacturer:

Other Similar products are found below :

[A82-1](#) [BGA622H6820XTSA1](#) [BGA 728L7 E6327](#) [BGB719N7ESDE6327XTMA1](#) [HMC397-SX](#) [HMC405](#) [HMC561-SX](#) [HMC8120-SX](#)
[HMC8121-SX](#) [HMC-ALH382-SX](#) [HMC-ALH476-SX](#) [SE2433T-R](#) [SMA3101-TL-E](#) [SMA39](#) [A66-1](#) [A66-3](#) [A67-1](#) [LX5535LQ](#) [LX5540LL](#)
[MAAM02350](#) [HMC3653LP3BETR](#) [HMC549MS8GETR](#) [HMC-ALH435-SX](#) [SMA101](#) [SMA32](#) [SMA411](#) [SMA531](#) [SST12LP19E-QX6E](#)
[WPM0510A](#) [HMC5929LS6TR](#) [HMC5879LS7TR](#) [HMC1126](#) [HMC1087F10](#) [HMC1086](#) [HMC1016](#) [SMA1212](#) [MAX2689EWS+T](#)
[MAAMSS0041TR](#) [MAAM37000-A1G](#) [LTC6430AIUF-15#PBF](#) [CHA5115-QDG](#) [SMA70-2](#) [SMA4011](#) [A231](#) [HMC-AUH232](#) [LX5511LQ](#)
[LX5511LQ-TR](#) [HMC7441-SX](#) [HMC-ALH310](#) [XD1001-BD-000V](#)