

Product Overview

The TQP9421 is a high-linearity two-stage power amplifier in a low-cost surface-mount package with on-chip bias control and temperature control circuits, suitable for small cell base station applications.

The TQP9421 provides 30 dB gain and +27 dBm linear power over the 2.11–2.17 GHz frequency range. This amplifier is able to achieve –50 dBc ACLR at +27 dBm output power using 20 MHz LTE signal.

The TQP9421 integrates two high performance amplifier stages onto a module to allow for a compact system design and requires very few external components for operation. The amplifier is bias adjustable allowing the amplifier's power consumption to be optimized. The TQP9421 is available in a 7 x 7 mm surface mount package.

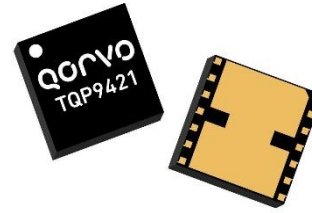

7 mm x 7 mm leadless SMT Package

Key Features

- 2.11 – 2.17 GHz Frequency Range
- Fully integrated, 2 Stage Power Amplifier
- Internally Matched 50 Ω Input/Output
- –50 dBc ACLR at $P_{avg} = +27$ dBm
- 30 dB Gain
- 14.5% PAE at +27 dBm
- 420 mA Quiescent Current
- On-chip Control Bias and Temp. Comp Circuit

Functional Block Diagram

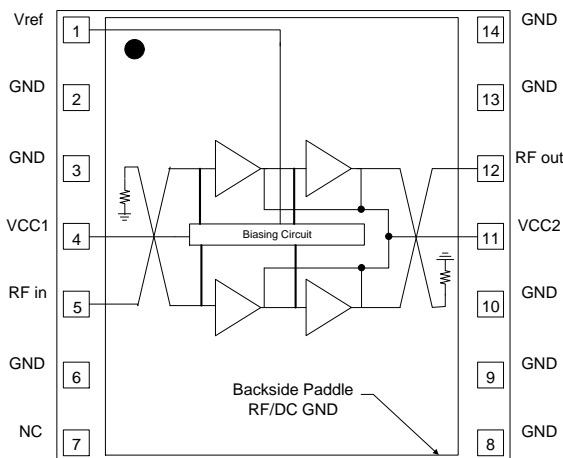

Top View

Applications

- Small Cell / Picocell
- Enterprise Femtocell
- Customer Premises Equipment (CPE)
- Data Cards and Terminals
- Distributed Antenna Systems (DAS)
- Booster Amps, Repeaters

Ordering Information

Part No.	Description
TQP9421	High Linearity 0.5 W Small Cell PA
TQP9421-PCB	2.11 – 2.17 GHz Evaluation board
Standard T/R size = 2500 pieces on a 13" reel	

Absolute Maximum Ratings

Parameter	Rating
Storage Temperature	-55 to +150 °C
Supply Voltage (V _{CC})	+6 V
V _{ref}	+3.5 V
RF Input Power, CW, 50Ω, T=25°C	+13 dBm
T _j at T _{CASE} = 125°C	+205°C

Operation of this device outside the parameter ranges given above may cause permanent damage.

Recommended Operating Conditions

Parameter	Min	Typ	Max	Units
V _{CC1} , V _{CC2}	+3.6	+4.5	+5.25	V
V _{ref}	+2.75	+2.85	+2.95	V
T _{CASE}	-40		+85	°C
T _j at T _{CASE} max			+165	°C

Electrical specifications are measured at specified test conditions. Specifications are not guaranteed over all recommended operating conditions.

Electrical Specifications

Test conditions unless otherwise noted: V_{CC1} = V_{CC2} = +4.5 V, V_{ref} = +2.85 V, Temp = +25 °C

Parameter	Conditions	Min	Typ	Max	Units
Operational Frequency Range		2110		2170	MHz
Test Frequency			2140		MHz
Gain		27	30	33	dB
Input Return Loss		15	20		dB
Output Return Loss		15	25		dB
P1dB			+35.5		dBm
ACLR	P _{OUT} = +27 dBm, 20 MHz LTE E-TM1.1, 9.5 dB PAR		-50	-47	dBc
ACLR	P _{OUT} = +27 dBm, 2X20 MHz LTE E-TM1.1, 9.5dB PAR		-42		dBc
ACLR	P _{OUT} = +27 dBm, 15 MHz LTE E-TM1.1, 9.5dB PAR		-50		dBc
ACLR	P _{OUT} = +27 dBm, 10 MHz LTE E-TM1.1, 9.5dB PAR		-51		dBc
ACLR	P _{OUT} = +27 dBm, 5 MHz LTE E-TM1.1, 9.5dB PAR		-50		dBc
Power Added Efficiency	P _{OUT} = +27 dBm, 20 MHz LTE E-TM1.1, 9.5 dB PAR	13	14.5		%
Quiescent Current, I _{CC1}	V _{CC1} + V _{CC2}	330	420	510	mA
Leakage Current	V _{CC} = +4.5V, V _{ref} = 0V		3	10	μA
Reference Current, I _{ref}	Temp = -40°C to +85°C, V _{ref} = +2.85V		13	19.5	mA
Operational Current, I _{CC}	P _{out} = +27 dBm		680	920	mA
Switching Speed	Rise time (10%-90%)		715		ns
	Fall time (90%-10%)		1370		ns
Spurious Output Level	P _{out} ≤ +27dBm, In & Out of band load VSWR ≤ 10:1		-60		dBc
VSWR survivability	No permanent degradation or failure	10:1			-
Harmonics	2F ₀ (P _{out} = 27 dBm), CW signal		-38	-33	dBc
	3F ₀ (P _{out} = 27 dBm), CW signal		-42	-37	dBc
	4F ₀ (P _{out} = 27 dBm), CW signal		-42	-37	dBc
Thermal Resistance, θ _{jc}	Module (junction to case)			18.5	°C/W

Notes:

- Current through V_{cc1} does not vary with power. V_{cc1} provides the bias voltage to the current mirror circuit along with V_{ref} to set the bias point for the whole amplifier.

Parameter	Conditions	-40°C	+25°C	+85°C	Units
Gain	Small Signal	31.5	30	28.7	dB
ACLR	P _{OUT} = +27 dBm, 20 MHz LTE E-TM1.1, 9.5dB PAR	-50	-51	-49.5	dBc
PAE	P _{OUT} = +27 dBm, 20 MHz LTE E-TM1.1, 9.5dB PAR	15.5	14.5	13.5	%
P1dB		+36.1	+35.5	+34.2	dBm

Test Frequency = 2140MHz

TQP9421 Application Circuit Schematic and Layout

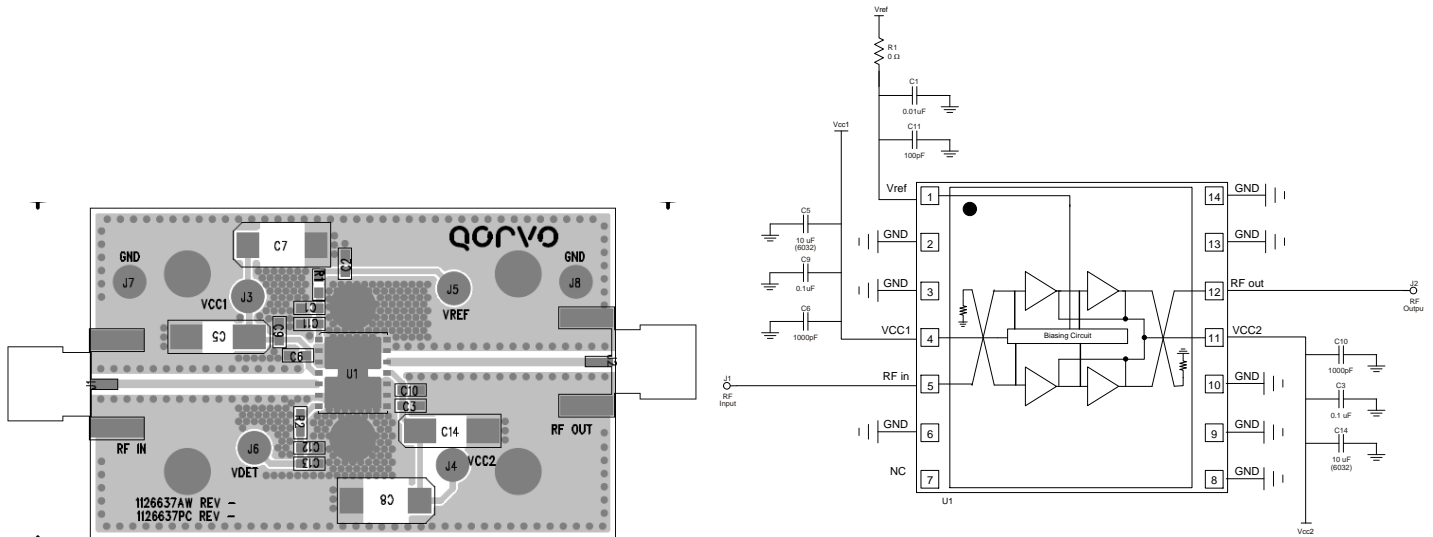

Bill of Material - TQP9421 Evaluation Board

Ref Des	Value	Description	Manuf.	Part Number
n/a	n/a	Printed Circuit Board	Qorvo	
U1	n/a	High Linearity 0.5 W Power Amplifier	Qorvo	TQP9421
R1	0 Ω	Resistor, Chip, 0603, 5%	various	
C1	0.01 uF	Capacitor, Chip, 0603, 5%	various	
C11	100 pF	Capacitor, Chip, 0603, 5%	various	
C3, C9	0.1 uF	Capacitor, Chip, 0603, 5%	various	
C5, C14	10 uF	Capacitor, Chip, 6032, 10%, Tantalum	various	
C6, C10	1000 pF	Capacitor, Chip, 0603, NPO/COG, 5%	various	

Vcc1=Vcc2=4.5V, Pout=27dBm, Signal PAR=9.5dB

LTE signal BW	5MHz	10MHz	15MHz	20MHz	2X20MHz	Units
ACLR1-Low	-50.6	-50.7	-50.3	-50.9	-41.8	dBc
ACLR1-high	-50.4	-50.6	-50.9	-50.8	-42.4	dBc

Performance Plots

Test conditions unless otherwise noted: $V_{CC1} = V_{CC2} = +4.5V$, $V_{ref} = +2.85V$, LTE signal PAR = 9.5dB, Temp. = +25 °C

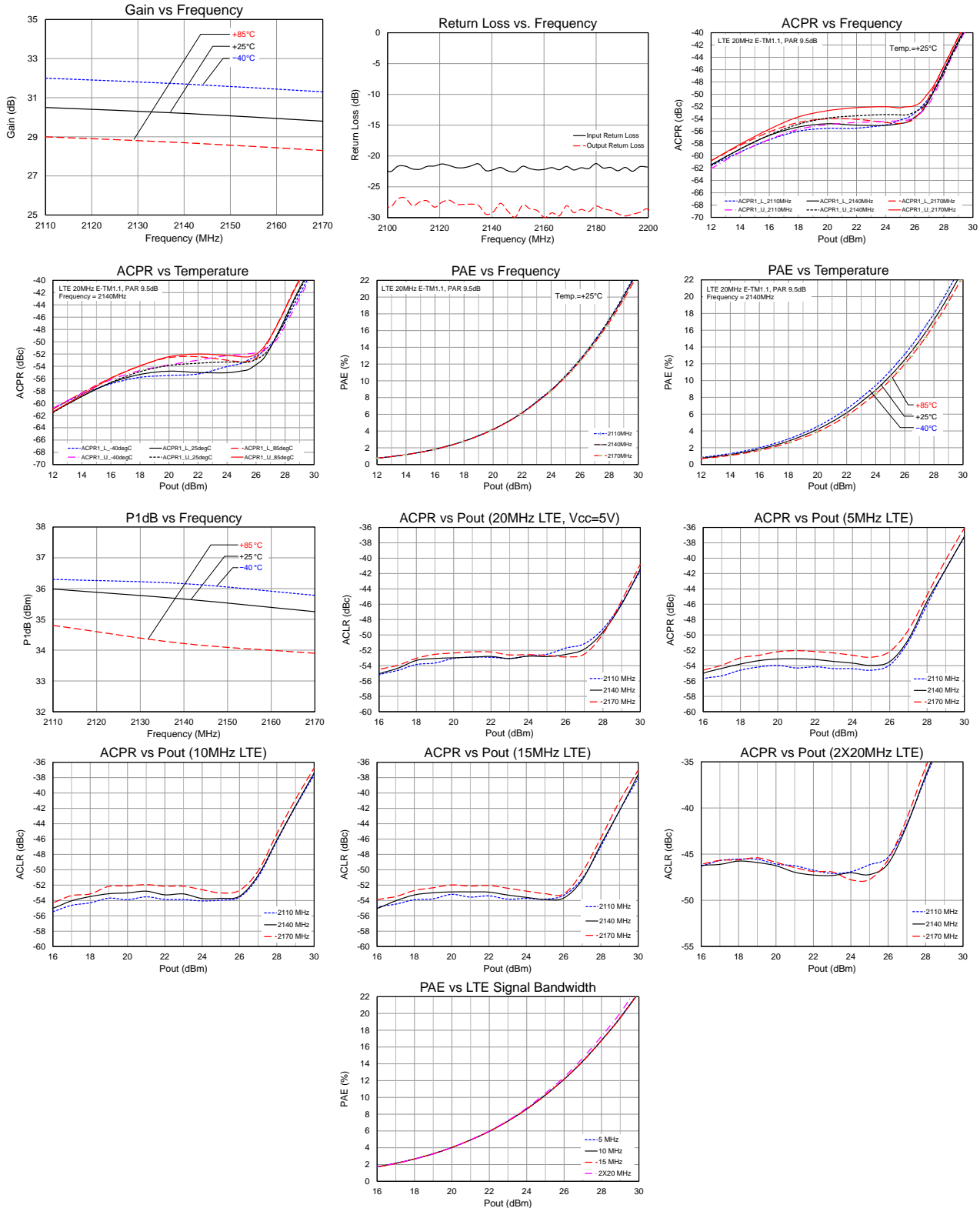

Pin Configuration and Description

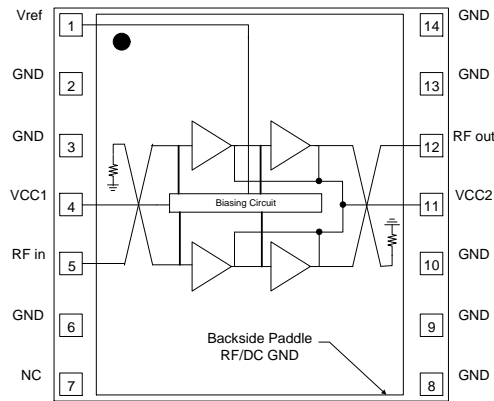

Pin No.	Label	Description
1	Vref	Provides reference voltage for internal active biasing circuit
2, 3, 6, 8, 9, 10, 13, 14	GND	RF and DC ground.
4	VCC1	Bias voltage for current mirror in combination with Vref to set the bias point.
5	RFin	RF input pin. The DC is internally blocked at this pin.
7	NC	No internal connection. Can be left open or grounded for mounting integrity.
11	VCC2	Supply to all stages.
12	RFout	RF output pin. The DC is internally blocked at this pin.
Backside Paddle	RF/DC GND	RF/DC ground. See PCB Mounting Pattern for suggested footprint.

Evaluation Board PCB Information

Qorvo PCB 1126637 Material and Stack-up

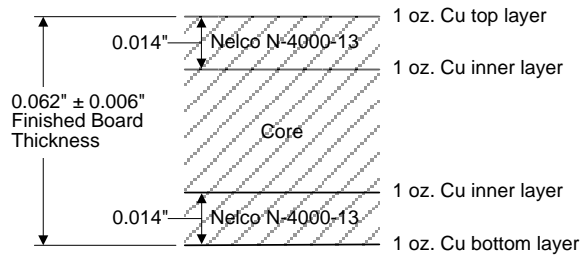

50 ohm line dimensions: width = .028"
spacing = .028".

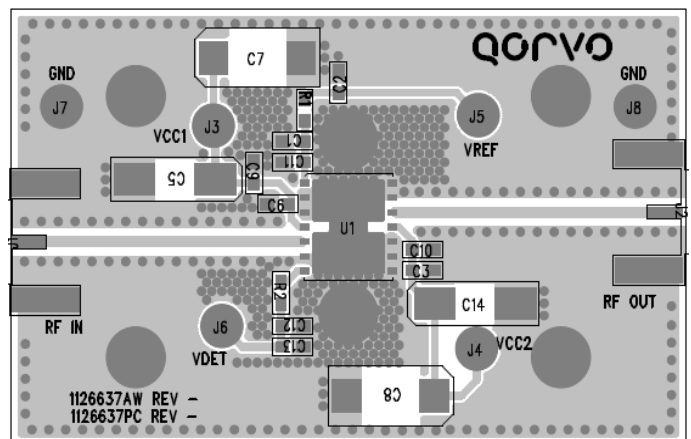

Mechanical Information

Package Marking and Dimensions

Marking: Part number – TQP9421
Trace code – XXXX

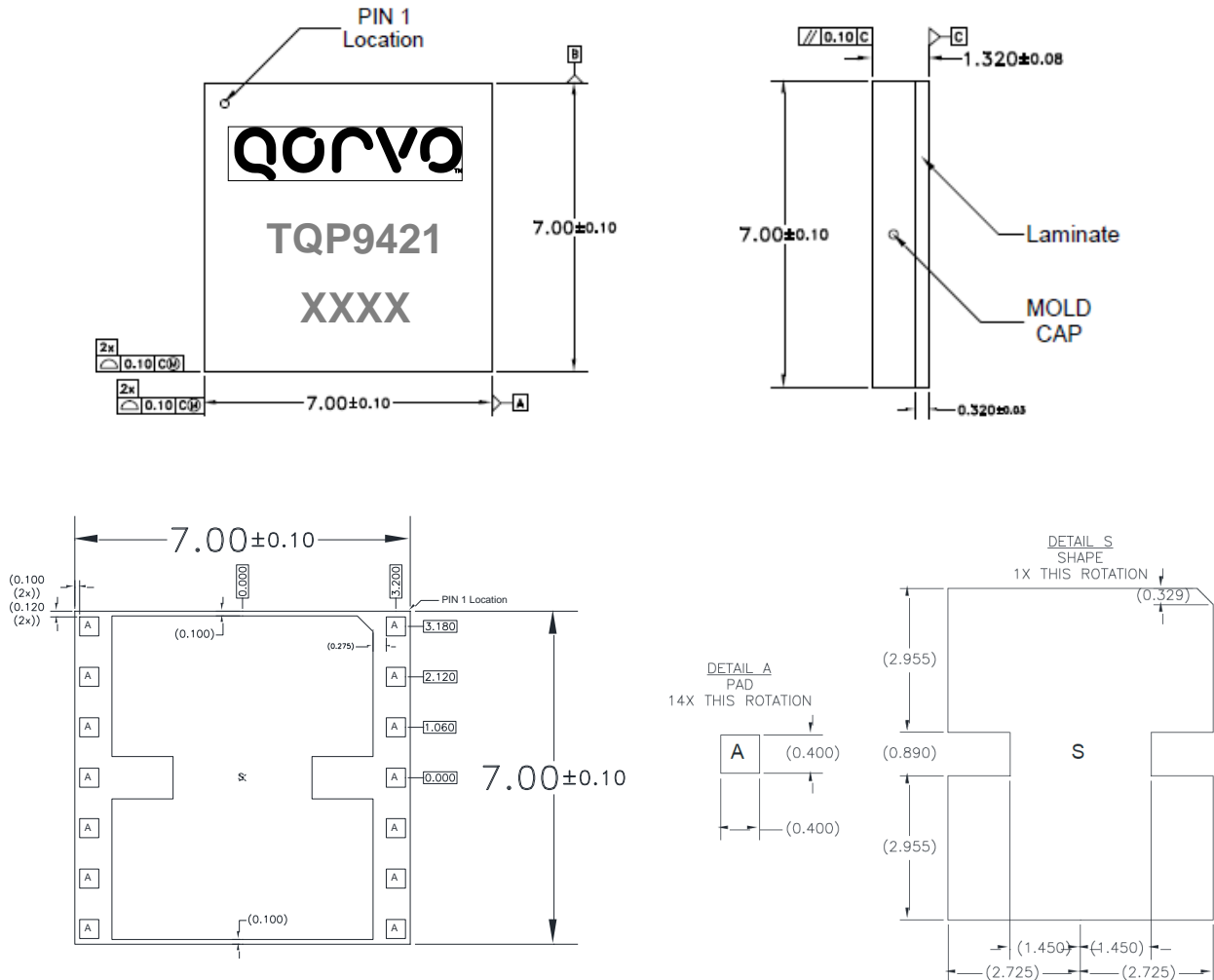

Notes:

1. All dimensions are in millimeters. Angles are in degrees.
2. Dimension and tolerance formats conform to ASME Y14.4M-1994.
3. The terminal #1 identifier and terminal numbering conform to JESD 95-1 SPP-012.

PCB Mounting Pattern

Recommend PCB land-pad pattern metallization (Top View)

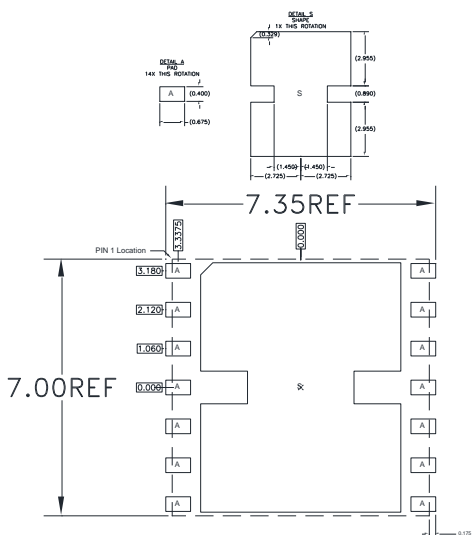

RECOMMENDED
LAND PATTERN

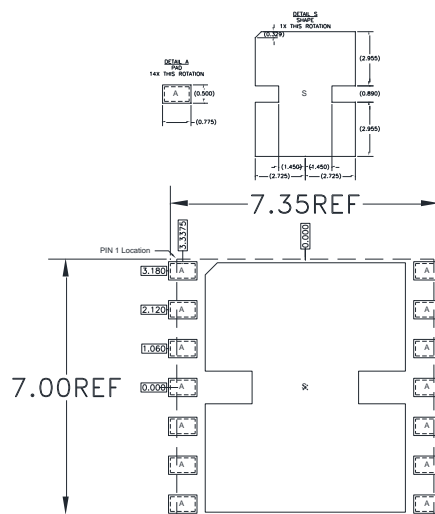

RECOMMENDED
LAND PATTERN MASK

Notes:

1. A heat sink underneath the area of the PCB for the mounted device is strictly required for proper thermal operation. Damage to the device can occur without the use of one.
2. Ground / thermal vias are critical for the proper performance of this device. Vias should use a .35mm (#80 / .0135") diameter drill and have a final plated thru diameter of .25 mm (.010").
3. Add as much copper as possible to inner and outer layers near the part to ensure optimal thermal performance.

Handling Precautions

Parameter	Rating	Standard
ESD – Human Body Model (HBM)	Class 2	ESDA / JEDEC JS-001-2012
ESD – Charged Device Model (CDM)	Class C3	JEDEC JESD22-C101F
MSL – Moisture Sensitivity Level	Level 3	IPC/JEDEC J-STD-020



Caution!
ESD-Sensitive Device

Solderability

Compatible with both lead-free (260°C max. reflow temp.) and tin/lead (245°C max. reflow temp.) soldering processes. Solder profiles available upon request.

Contact plating: Electrolytic plated Au over Ni

RoHS Compliance

This part is compliant with the 2011/65/EU RoHS directive (Restrictions on the Use of Certain Hazardous Substances in Electrical and Electronic Equipment) as amended by Directive 2015/863/EU. This product also has the following attributes:

- Product uses RoHS Exemption 7c-I to meet RoHS Compliance requirements.
- Halogen Free (Chlorine, Bromine)
- Antimony Free
- TBBP-A (C₁₅H₁₂Br₄O₂) Free
- PFOS Free
- SVHC Free

Contact Information

For the latest specifications, additional product information, worldwide sales and distribution locations:

Web: www.qorvo.com

Tel: 1-844-890-8163

Email: customer.support@qorvo.com

For technical questions and application information:

Email: appsupport@qorvo.com

Important Notice

The information contained herein is believed to be reliable; however, Qorvo makes no warranties regarding the information contained herein and assumes no responsibility or liability whatsoever for the use of the information contained herein. All information contained herein is subject to change without notice. Customers should obtain and verify the latest relevant information before placing orders for Qorvo products. The information contained herein or any use of such information does not grant, explicitly or implicitly, to any party any patent rights, licenses, or any other intellectual property rights, whether with regard to such information itself or anything described by such information. **THIS INFORMATION DOES NOT CONSTITUTE A WARRANTY WITH RESPECT TO THE PRODUCTS DESCRIBED HEREIN, AND QORVO HEREBY DISCLAIMS ANY AND ALL WARRANTIES WITH RESPECT TO SUCH PRODUCTS WHETHER EXPRESS OR IMPLIED BY LAW, COURSE OF DEALING, COURSE OF PERFORMANCE, USAGE OF TRADE OR OTHERWISE, INCLUDING THE IMPLIED WARRANTIES OF MERCHANTABILITY AND FITNESS FOR A PARTICULAR PURPOSE.**

Without limiting the generality of the foregoing, Qorvo products are not warranted or authorized for use as critical components in medical, life-saving, or life-sustaining applications, or other applications where a failure would reasonably be expected to cause severe personal injury or death.

Copyright 2016 © Qorvo, Inc. | Qorvo is a registered trademark of Qorvo, Inc.

X-ON Electronics

Largest Supplier of Electrical and Electronic Components

Click to view similar products for [RF Amplifier](#) category:

Click to view products by [Qorvo](#) manufacturer:

Other Similar products are found below :

[A82-1](#) [BGA622H6820XTSA1](#) [BGA 728L7 E6327](#) [BGB719N7ESDE6327XTMA1](#) [HMC397-SX](#) [HMC405](#) [HMC561-SX](#) [HMC8120-SX](#)
[HMC8121-SX](#) [HMC-ALH382-SX](#) [HMC-ALH476-SX](#) [SE2433T-R](#) [SMA3101-TL-E](#) [SMA39](#) [A66-1](#) [A66-3](#) [A67-1](#) [LX5535LQ](#) [LX5540LL](#)
[MAAM02350](#) [HMC3653LP3BETR](#) [HMC549MS8GETR](#) [HMC-ALH435-SX](#) [SMA101](#) [SMA32](#) [SMA411](#) [SMA531](#) [SST12LP19E-QX6E](#)
[WPM0510A](#) [HMC5929LS6TR](#) [HMC5879LS7TR](#) [HMC1126](#) [HMC1087F10](#) [HMC1086](#) [HMC1016](#) [SMA1212](#) [MAX2689EWS+T](#)
[MAAMSS0041TR](#) [MAAM37000-A1G](#) [LTC6430AIUF-15#PBF](#) [CHA5115-QDG](#) [SMA70-2](#) [SMA4011](#) [A231](#) [HMC-AUH232](#) [LX5511LQ](#)
[LX5511LQ-TR](#) [HMC7441-SX](#) [HMC-ALH310](#) [XD1001-BD-000V](#)