

## Feature

- 40V,160A  
 $R_{DS(ON)} < 2.8m\Omega @ V_{GS}=10V$  TYP:2.4 m $\Omega$   
 $R_{DS(ON)} < 4.0m\Omega @ V_{GS}=4.5V$  TYP:3.2m $\Omega$
- Advanced Trench Technology
- Lead free product is acquired
- Excellent  $R_{DS(ON)}$  and Low Gate Charge

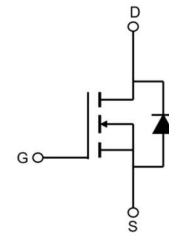

Schematic Diagram

## Application

- PWM applications
- Load Switch
- Power management

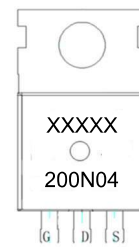

Marking and pin assignment

## Package Marking and Ordering Information

Device Marking	Device	Device Package	Reel Size	Tape width	Quantity (PCS)
200N04	AP200N04	TO-220		-	1000

## ABSOLUTE MAXIMUM RATINGS ( $T_a=25^{\circ}C$ unless otherwise noted)

Parameter	Symbol	Value	Unit
Drain-Source Voltage	$V_{DS}$	40	V
Gate-Source Voltage	$V_{GS}$	$\pm 20$	V
Continuous Drain Current ( $T_a=25^{\circ}C$ )	$I_D$	160	A
Continuous Drain Current ( $T_a=100^{\circ}C$ )	$I_D$	112	A
Pulsed Drain Current <sup>(1)</sup>	$I_{DM}$	520	A
Singel Pulsed Avalanche Energy <sup>(2)</sup>	$E_{AS}$	245	mJ
Power Dissipation	$P_D$	180	W
Thermal Resistance from Junction to Case <sup>(4)</sup>	$R_{\theta JC}$	0.83	$^{\circ}C/W$
Junction Temperature	$T_J$	150	$^{\circ}C$
Storage Temperature	$T_{STG}$	-55~ +150	$^{\circ}C$

MOSFET ELECTRICAL CHARACTERISTICS( $T_a=25^{\circ}\text{C}$  unless otherwise noted)

Parameter	Symbol	Test Condition	Min	Type	Max	Unit
<b>Static Characteristics</b>						
Drain-source breakdown voltage	$V_{(BR)DSS}$	$V_{GS} = 0V, I_D = 250\mu A$	40	-	-	V
Zero gate voltage drain current	$I_{DSS}$	$V_{DS} = 40V, V_{GS} = 0V$	-	-	1	$\mu A$
Gate-body leakage current	$I_{GSS}$	$V_{GS} = \pm 20V, V_{DS} = 0V$	-	-	$\pm 100$	nA
Gate threshold voltage <sup>(3)</sup>	$V_{GS(th)}$	$V_{DS} = V_{GS}, I_D = 250\mu A$	1	1.5	2.2	V
Drain-source on-resistance <sup>(3)</sup>	$R_{DS(on)}$	$V_{GS} = 10V, I_D = 50A$	-	2.4	2.8	m $\Omega$
		$V_{GS} = 4.5V, I_D = 30A$	-	3.2	4.0	
<b>Dynamic characteristics</b>						
Input Capacitance	$C_{iss}$	$V_{DS} = 20V, V_{GS} = 0V, f = 1MHz$	-	6260	-	pF
Output Capacitance	$C_{oss}$		-	523	-	
Reverse Transfer Capacitance	$C_{rss}$		-	727	-	
<b>Switching characteristics</b>						
Turn-on delay time	$t_{d(on)}$	$V_{DD} = 20V, I_D = 30A, R_L = 1\Omega$ $V_{GS} = 10V, R_G = 3\Omega$	-	16.8	-	ns
Turn-on rise time	$t_r$		-	38.1	-	
Turn-off delay time	$t_{d(off)}$		-	116.4	-	
Turn-off fall time	$t_f$		-	33.4	-	
Total Gate Charge	$Q_g$	$V_{DS} = 20V, I_D = 30A,$ $V_{GS} = 10V$	-	129.6	-	nC
Gate-Source Charge	$Q_{gs}$		-	20.3	-	
Gate-Drain Charge	$Q_{gd}$		-	27.4	-	
<b>Source-Drain Diode characteristics</b>						
Diode Forward voltage <sup>(3)</sup>	$V_{DS}$	$V_{GS} = 0V, I_S = 10A$	-	-	1.2	V
Diode Forward current <sup>(4)</sup>	$I_S$		-	-	160	A
Body Diode Reverse Recovery Time	$t_{rr}$	$T_J = 25^{\circ}, I_F = 30A, di/dt = 100A/\mu s$		23.5		ns
Body Diode Reverse Recovery Charge	$Q_{rr}$	$T_J = 25^{\circ}, I_F = 30A, di/dt = 100A/\mu s$		12.8		nc

**Notes:**

1. Repetitive Rating: pulse width limited by maximum junction temperature
2. EAS Condition:  $T_J = 25^{\circ}\text{C}, V_{DD} = 20V, R_G = 25\Omega, L = 0.5\text{mH}$
3. Pulse Test: pulse width  $\leq 300\mu s$ , duty cycle  $\leq 2\%$
4. Surface Mounted on FR4 Board,  $t \leq 10\text{ sec}$

**Test Circuit & Waveform**

Gate Charge Test Circuit & Waveform

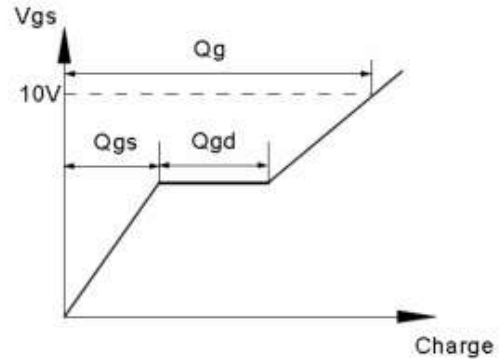
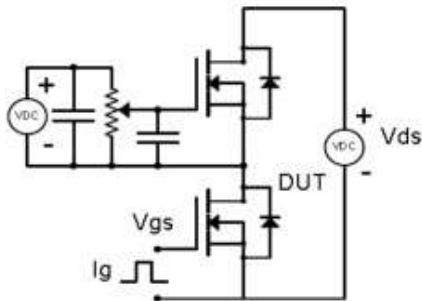

Resistive Switching Test Circuit & Waveforms

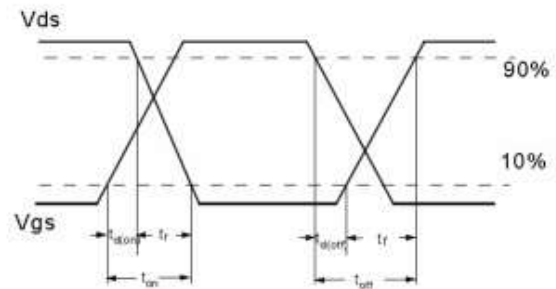
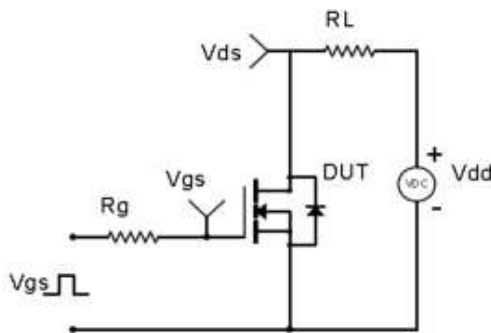

Unclamped Inductive Switching (UIS) Test Circuit & Waveforms

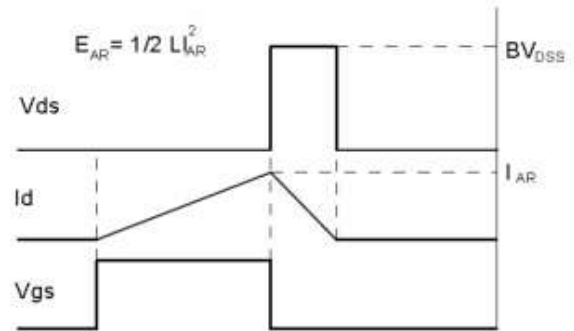
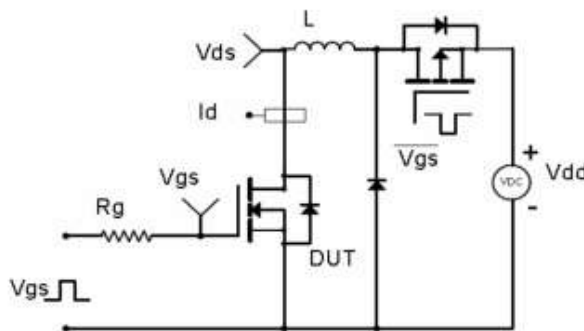

Diode Recovery Test Circuit & Waveforms

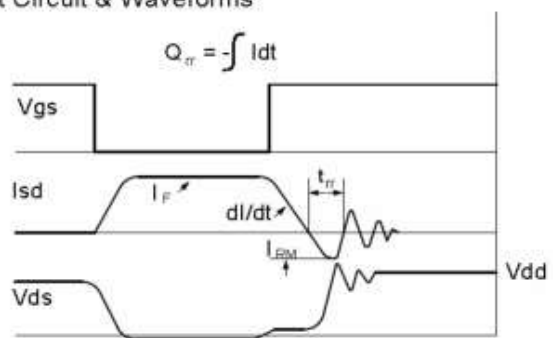
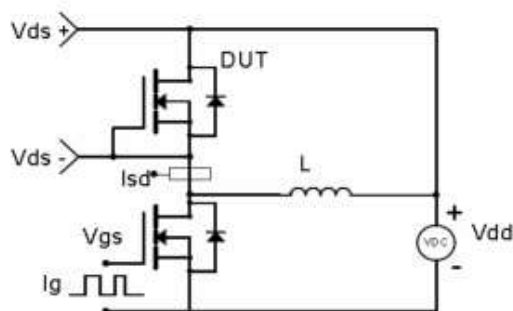

Fig1. Power Dissipation Derating Curve

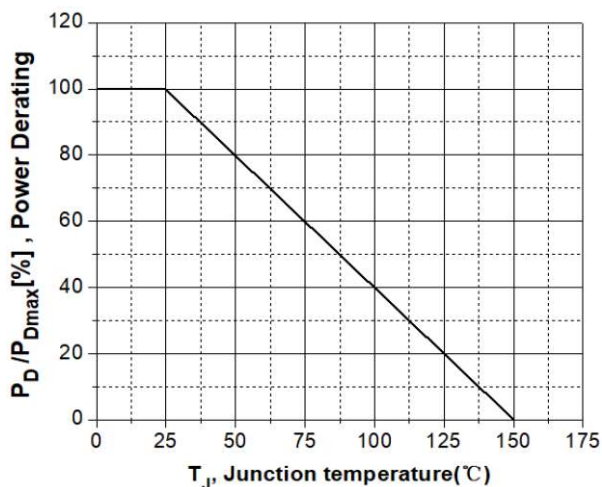

Fig2. Avalanche Energy Derating Curve vs. Junction Temperature

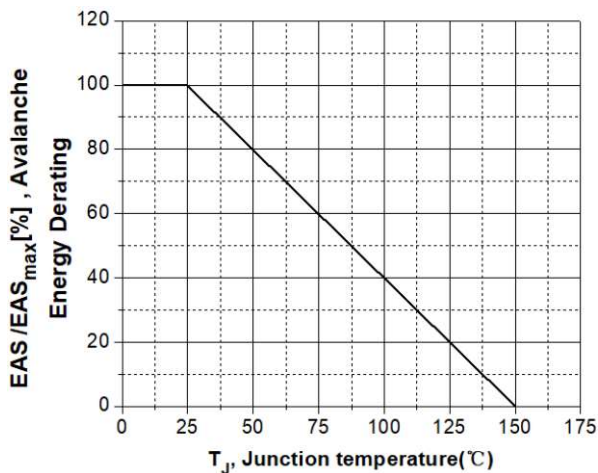

Fig3. Typical Output Characteristics @  $T_J = 125^\circ\text{C}$

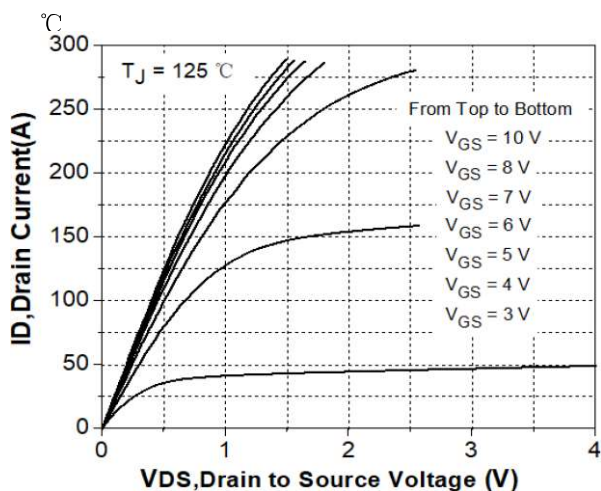

Fig4. Transconductance vs. Drain Current @  $T_J = -25/25/75/125^\circ\text{C}$

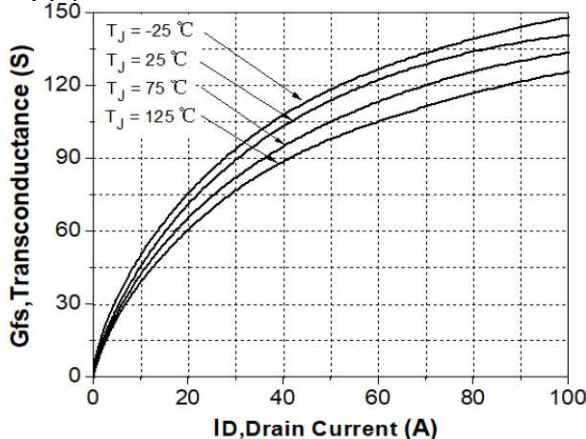

Fig5. Typical Transfer Characteristics

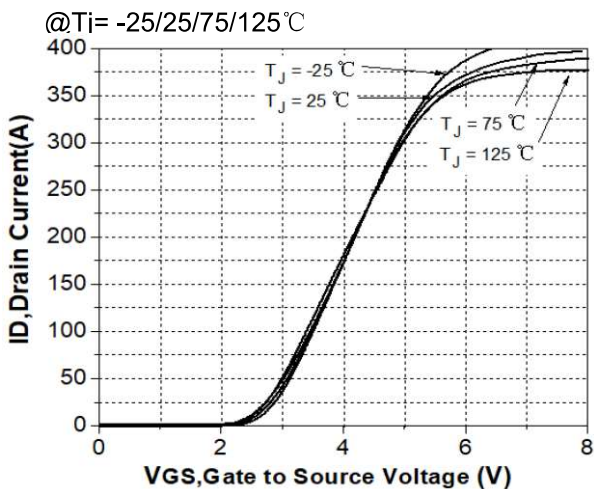

Fig6. Static Drain - Source On - State Resistance vs. Drain Current @  $T_J = -25^\circ\text{C}$

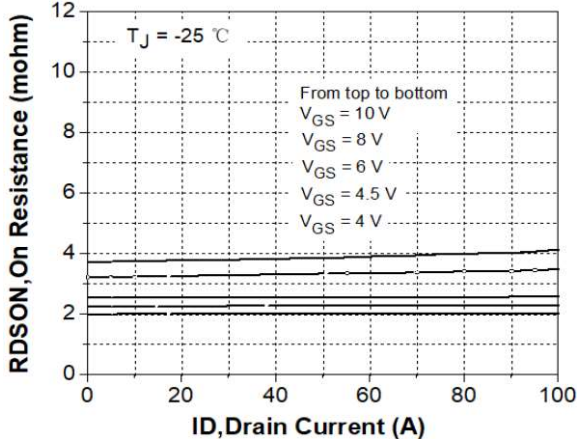

Fig7. Static Drain - Source On - State Resistance vs. Drain Current @Tj= 25°C

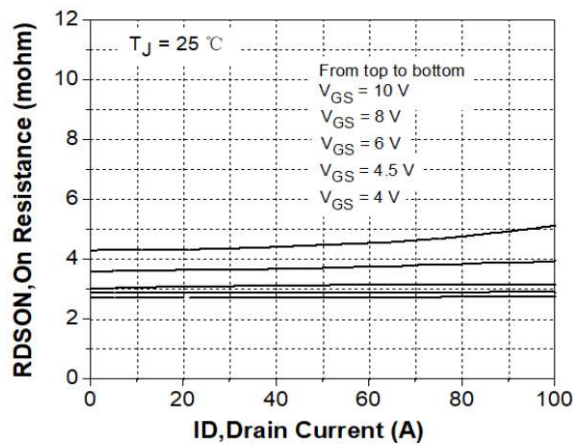

Fig8. Static Drain - Source On - State Resistance vs. Drain Current @Tj= 75°C

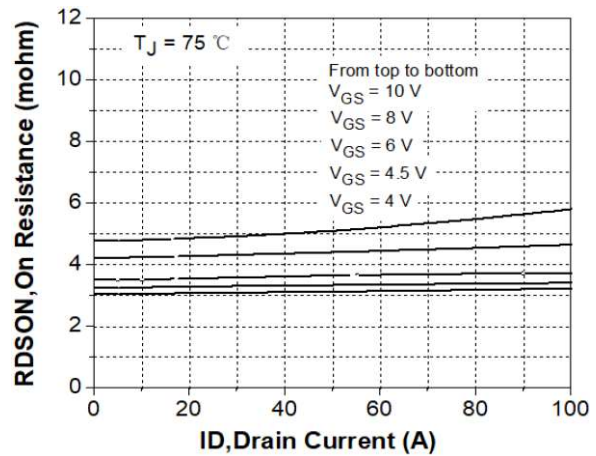

Fig9. Static Drain - Source On - State Resistance vs. Drain Current @Tj= 125°C

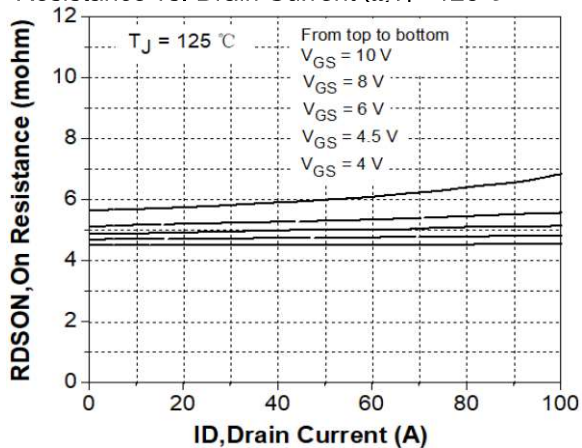

Fig10. Gate Charge Characteristics

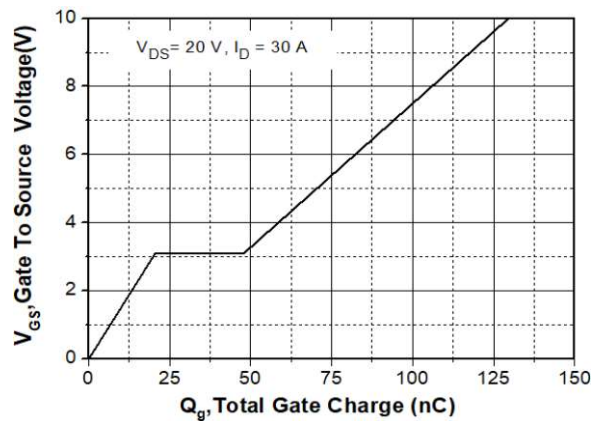

Fig11. Breakdown Voltage vs. Junction Temperature

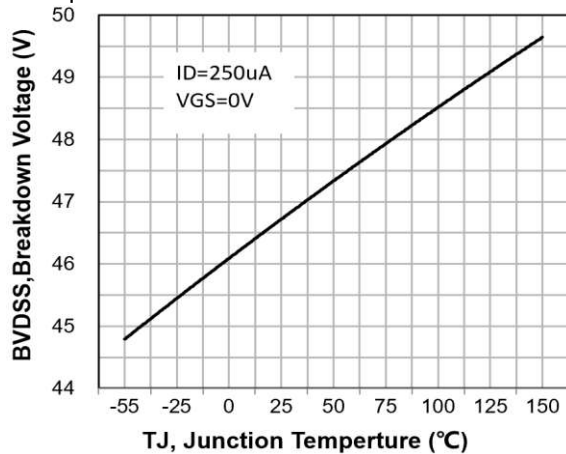

Fig12. Gate Threshold Voltage vs. Junction Temperature

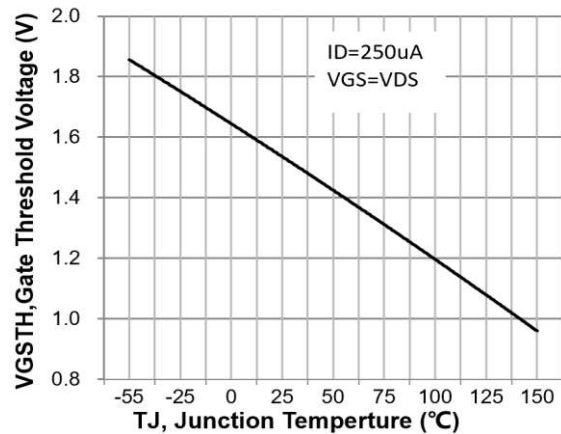

Fig13. Safe Operating Area

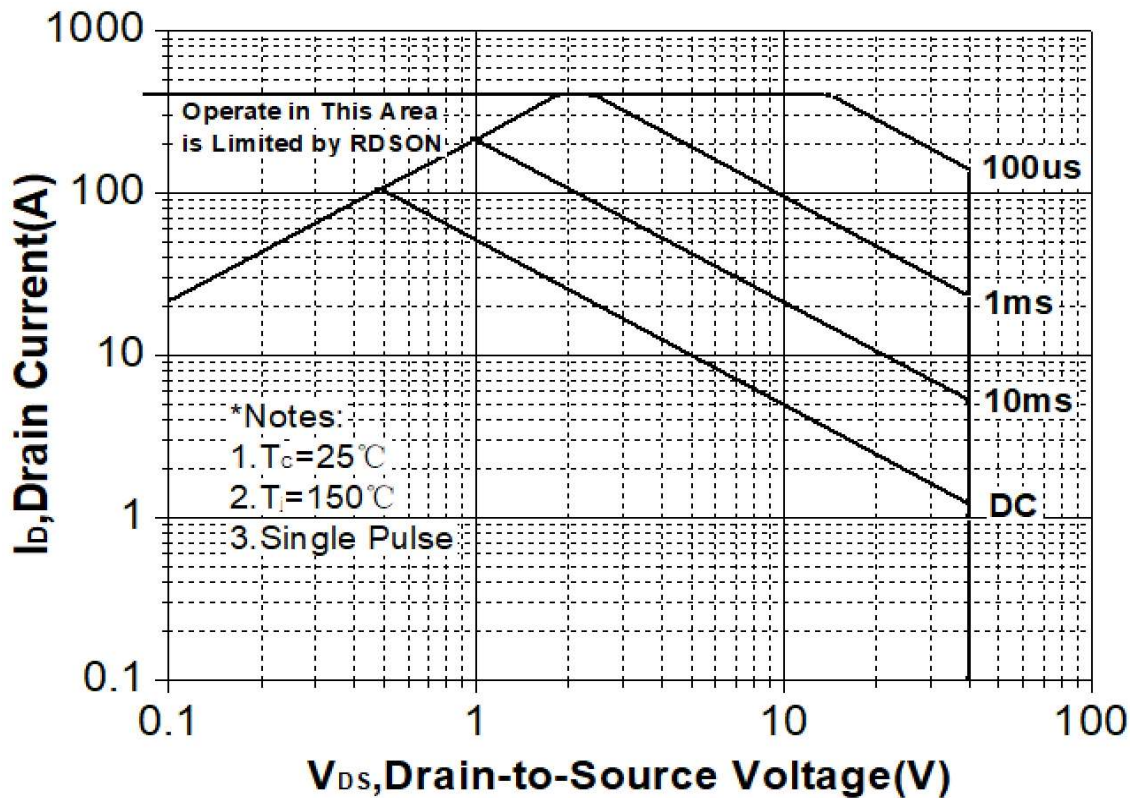

Fig14. Transient Thermal Response Curve

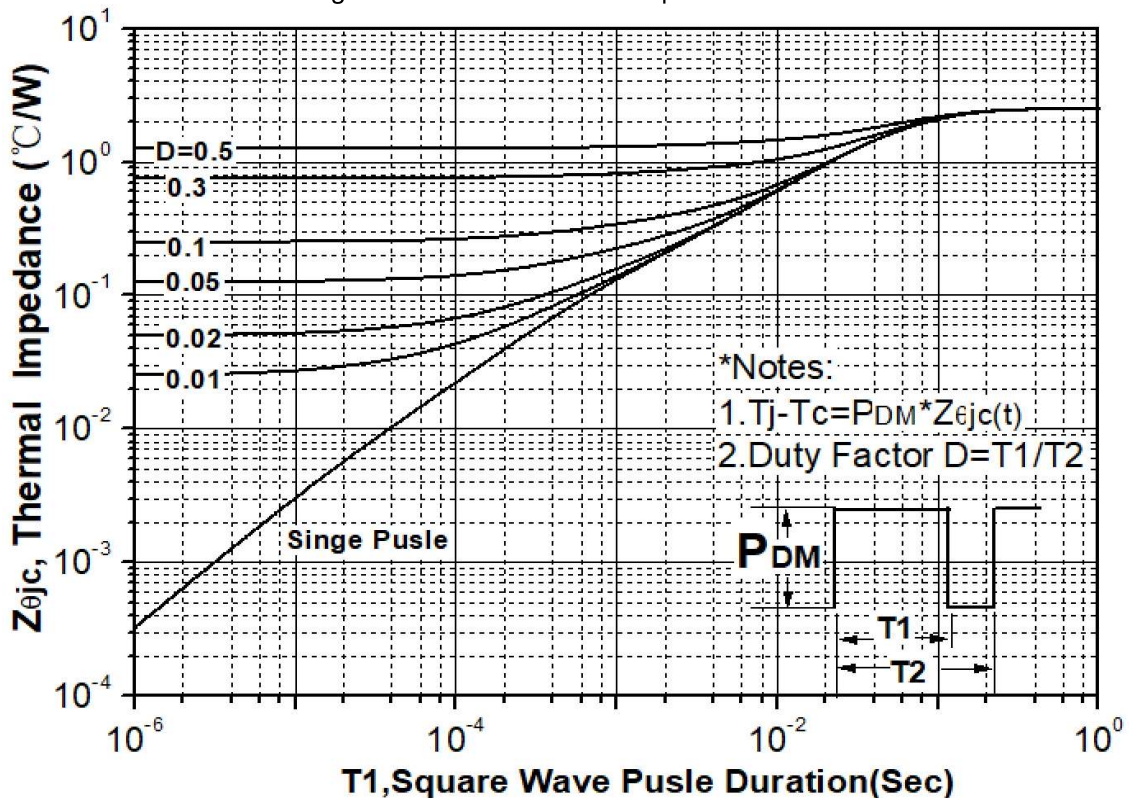

Fig15. On-Resistance Variation vs. Junction

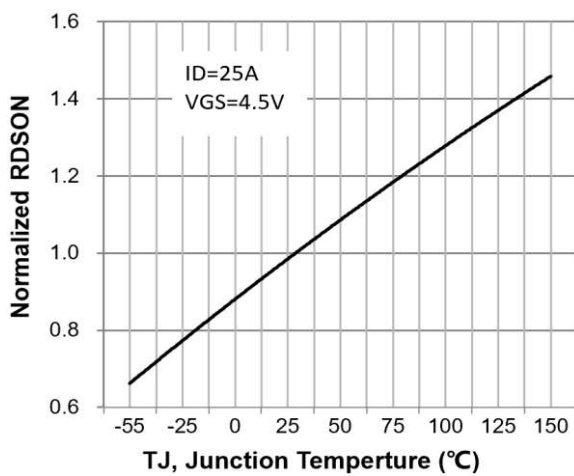

Fig16. Maximum Drain Current vs. Case Temperature

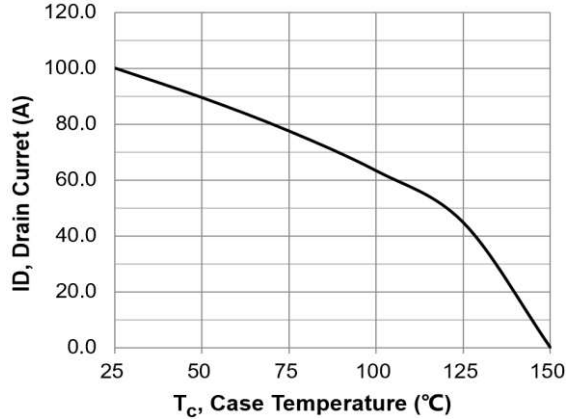

Fig17. Body Diode Forward Voltage vs. Reverse Drain Current

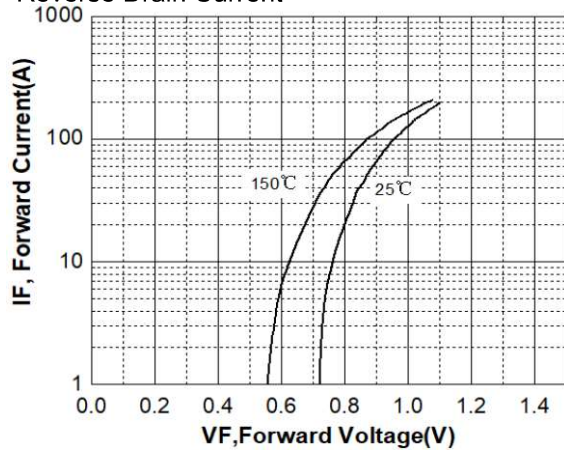
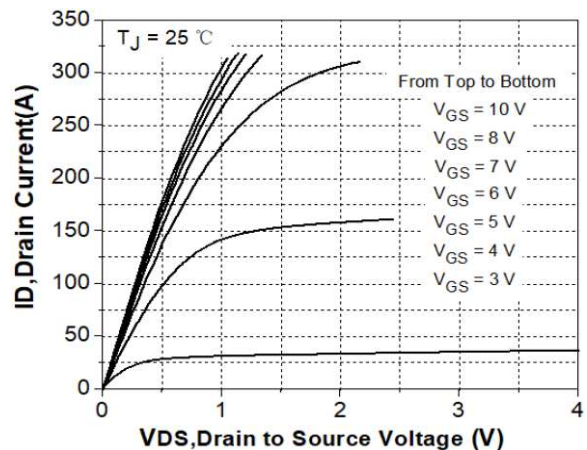

Fig18. Typical Output Characteristics@Tj=25°C



# AP200N04

N-Channel Enhancement Mosfet

### TO-220C Package Information

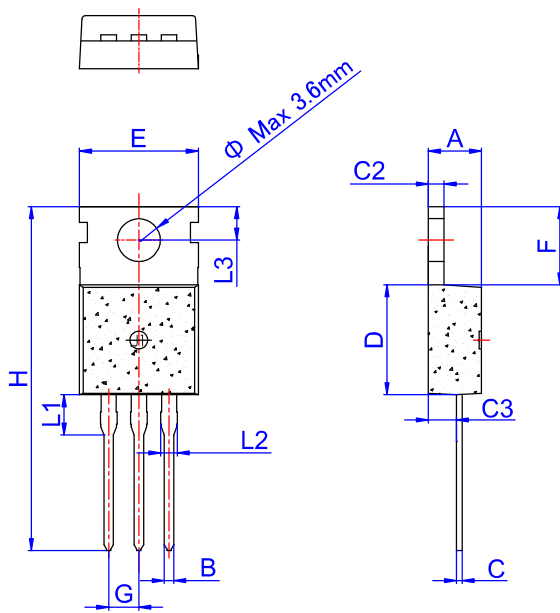

TO-220C

Ref.	Dimensions					
	Millimeters			Inches		
	Min.	Typ.	Max.	Min.	Typ.	Max.
A	4.40		4.60	0.173		0.181
B	0.70		0.90	0.028		0.035
C	0.45		0.60	0.018		0.024
C2	1.23		1.32	0.048		0.052
C3	2.20		2.60	0.087		0.102
D	8.90		9.90	0.350		0.390
E	9.90		10.3	0.390		0.406
F	6.30		6.90	0.248		0.272
G		2.54			0.1	
H	28.0		29.8	1.102		1.173
L1		3.39			0.133	
L2	1.14		1.70	0.045		0.067
L3	2.65		2.95	0.104		0.116
$\Phi$		3.6			0.142	



## X-ON Electronics

Largest Supplier of Electrical and Electronic Components

*Click to view similar products for [MOSFET](#) category:*

*Click to view products by [Quan Li](#) manufacturer:*

Other Similar products are found below :

[IRFD120](#) [JANTX2N5237](#) [BUK455-60A/B](#) [MIC4420CM-TR](#) [VN1206L](#) [NDP4060](#) [SI4482DY](#) [IPS70R2K0CEAKMA1](#) [SQD23N06-31L-GE3](#)  
[TK16J60W,S1VQ\(O](#) [2SK2614\(TE16L1,Q\)](#) [DMN1017UCP3-7](#) [DMN1053UCP4-7](#) [SQJ469EP-T1-GE3](#) [NTE2384](#) [DMC2700UDMQ-7](#)  
[DMN2080UCB4-7](#) [DMN61D9UWQ-13](#) [US6M2GTR](#) [DMN31D5UDJ-7](#) [DMP22D4UFO-7B](#) [DMN1006UCA6-7](#) [DMN16M9UCA6-7](#)  
[STF5N65M6](#) [IRF40H233XTMA1](#) [STU5N65M6](#) [DMN6022SSD-13](#) [DMN13M9UCA6-7](#) [DMTH10H4M6SPS-13](#) [DMN2990UFB-7B](#)  
[IPB80P04P405ATMA2](#) [2N7002W-G](#) [MCAC30N06Y-TP](#) [MCQ7328-TP](#) [BXP7N65D](#) [BXP4N65F](#) [AOL1454G](#) [WMJ80N60C4](#) [BXP2N20L](#)  
[BXP2N65D](#) [BXT1150N10J](#) [BXT1700P06M](#) [TSM60NB380CP ROG](#) [RQ7L055BGTCR](#) [DMNH15H110SK3-13](#) [SLF10N65ABV2](#)  
[BSO203SP](#) [BSO211P](#) [IPA60R230P6](#) [IPA60R460CE](#)