

AP2035Q

N-Channel Enhancement Mosfet

AIIPOWER

DATA SHEET

Feature

- 20V,70A
 $R_{DS(ON)} < 4m\Omega @ V_{GS}=4.5V$ TYP=3.1 m Ω
 $R_{DS(ON)} < 5.8m\Omega @ V_{GS}=2.5V$ TYP=4.0 m Ω
- Advanced Trench Technology
- Lead free product is acquired
- Excellent $R_{DS(ON)}$ and Low Gate Charge

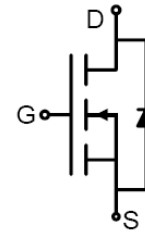

Schematic Diagram

Application

- PWM applications
- Load Switch
- Power management

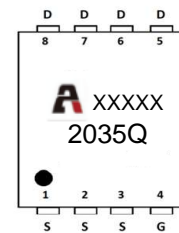

Marking and pin Assignment

Package Marking and Ordering Information

Device Marking	Device	Device Package	Reel Size	Tape width	Quantity (PCS)
2035Q	AP2035Q	PDFN3X3-8L	13 inch	-	5000

ABSOLUTE MAXIMUM RATINGS ($T_a=25^\circ\text{C}$ unless otherwise noted)

Parameter	Symbol	Value	Unit
Drain-Source Voltage	V_{DS}	20	V
Gate-Source Voltage	V_{GS}	± 12	V
Continuous Drain Current ($T_a=25^\circ\text{C}$)	I_D	70	A
Continuous Drain Current ($T_a=100^\circ\text{C}$)	I_D	52	A
Pulsed Drain Current ⁽¹⁾	I_{DM}	220	A
Singel Pulsed Avalanche Energy ⁽²⁾	E_{AS}	88	mJ
Power Dissipation	P_D	30	W
Thermal Resistance from Junction to Case ⁽⁴⁾	$R_{\theta JC}$	3.2	$^\circ\text{C}/\text{W}$
Junction Temperature	T_J	150	$^\circ\text{C}$
Storage Temperature	T_{STG}	-55~ +150	$^\circ\text{C}$

MOSFET ELECTRICAL CHARACTERISTICS($T_a=25^\circ\text{C}$ unless otherwise noted)

Parameter	Symbol	Test Condition	Min	Type	Max	Unit
Static Characteristics						
Drain-source breakdown voltage	$V_{(BR)DSS}$	$V_{GS} = 0V, I_D = 250\mu A$	20	-	-	V
Zero gate voltage drain current	I_{DSS}	$V_{DS} = 20V, V_{GS} = 0V$	-	-	1	μA
Gate-body leakage current	I_{GSS}	$V_{GS} = \pm 12V, V_{DS} = 0V$	-	-	± 100	nA
Gate threshold voltage ⁽³⁾	$V_{GS(th)}$	$V_{DS} = V_{GS}, I_D = 250\mu A$	0.5	0.7	0.9	V
Drain-source on-resistance ⁽³⁾	$R_{DS(on)}$	$V_{GS} = 4.5V, I_D = 30A$	-	3.1	4.0	m Ω
		$V_{GS} = 2.5V, I_D = 20A$	-	4.0	5.8	
Dynamic characteristics						
Input Capacitance	C_{iss}	$V_{DS} = 10V, V_{GS} = 0V, f = 1MHz$	-	2560	-	pF
Output Capacitance	C_{oss}		-	368	-	
Reverse Transfer Capacitance	C_{rss}		-	356	-	
Switching characteristics						
Turn-on delay time	$t_{d(on)}$	$V_{DD} = 10V, I_D = 30A,$ $V_{GS} = 4.5V, R_G = 1.8\Omega$	-	7.8	-	ns
Turn-on rise time	t_r		-	30	-	
Turn-off delay time	$t_{d(off)}$		-	50	-	
Turn-off fall time	t_f		-	42	-	
Total Gate Charge	Q_g	$V_{DS} = 10V, I_D = 30A,$ $V_{GS} = 4.5V$	-	38	-	nC
Gate-Source Charge	Q_{gs}		-	2.9	-	
Gate-Drain Charge	Q_{gd}		-	15	-	
Source-Drain Diode characteristics						
Diode Forward voltage ⁽³⁾	V_{DS}	$V_{GS} = 0V, I_S = 30A$	-	-	1.2	V
Diode Forward current ⁽⁴⁾	I_S		-	-	70	A

Notes:

1. Repetitive Rating: pulse width limited by maximum junction temperature
2. EAS Condition: $T_J = 25^\circ\text{C}, V_{DD} = 15V, R_G = 25\Omega, L = 0.5\text{mH}$
3. Pulse Test: pulse width $\leq 300\mu\text{s}$, duty cycle $\leq 2\%$
4. Surface Mounted on FR4 Board, $t \leq 10\text{ sec}$

Test Circuit & Waveform

Gate Charge Test Circuit & Waveform

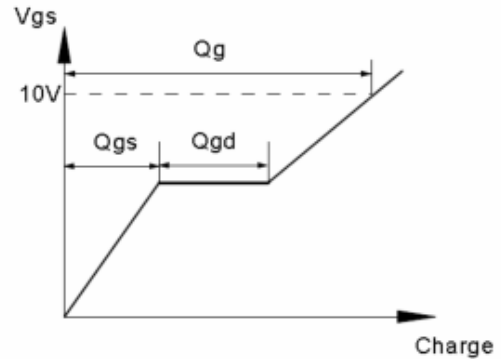
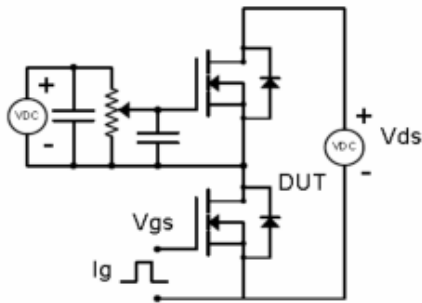

Resistive Switching Test Circuit & Waveforms

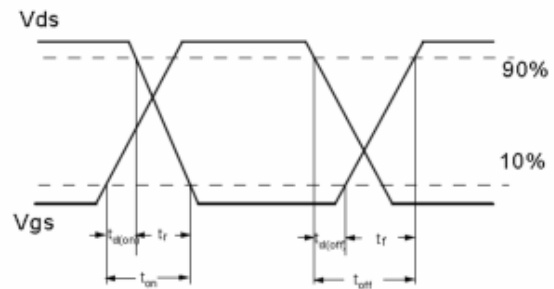
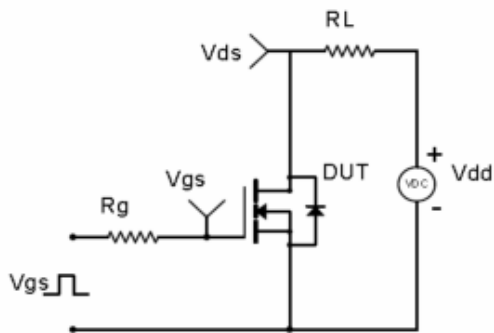

Unclamped Inductive Switching (UIS) Test Circuit & Waveforms

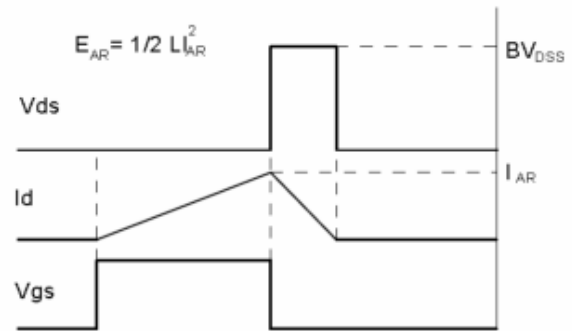
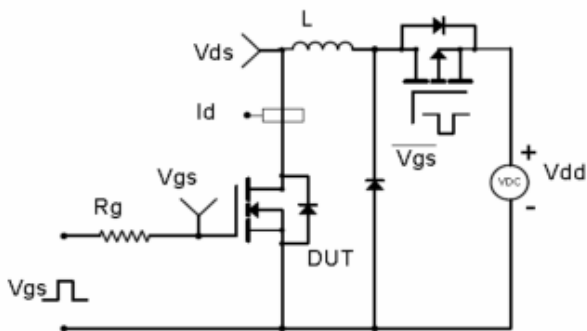

Diode Recovery Test Circuit & Waveforms

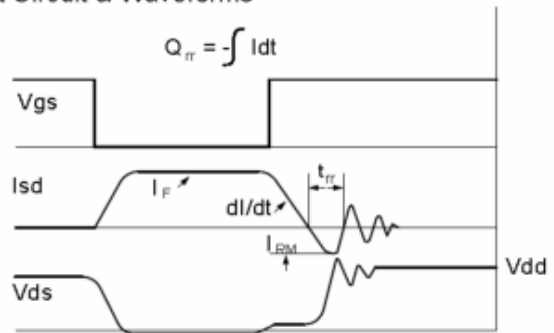
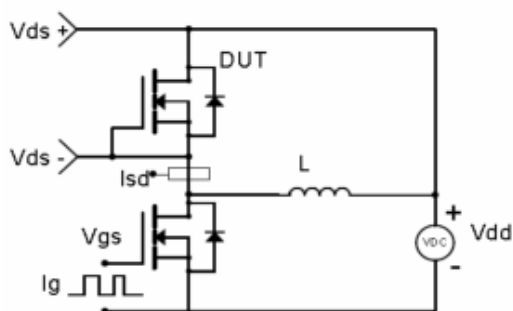

Figure 1: Output Characteristics

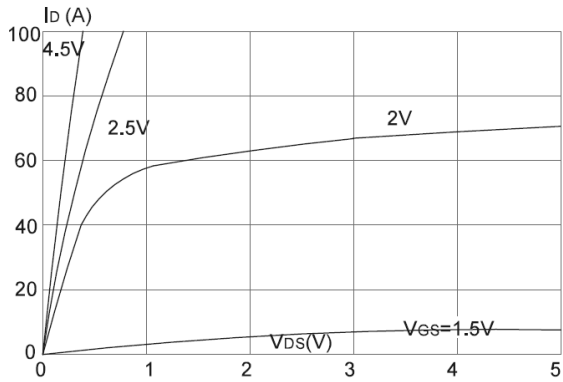

Figure 2: Typical Transfer Characteristics

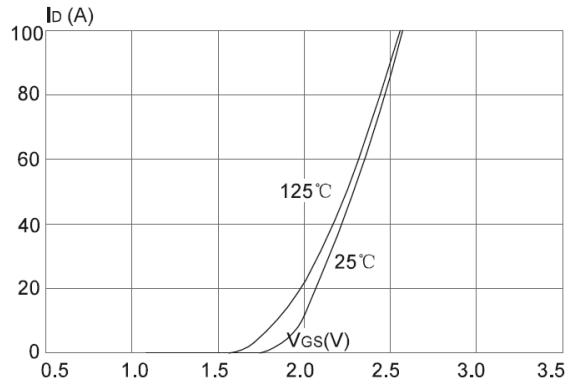

Figure 3: On-resistance vs. Drain Current

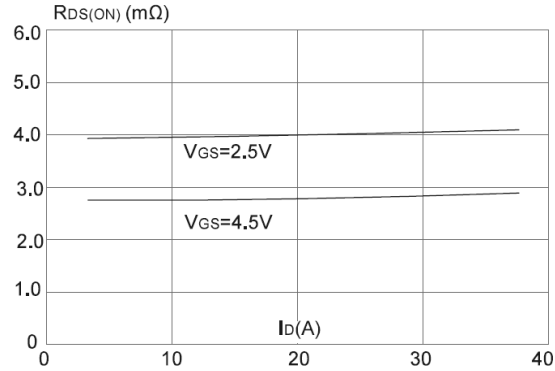

Figure 4: Body Diode Characteristics

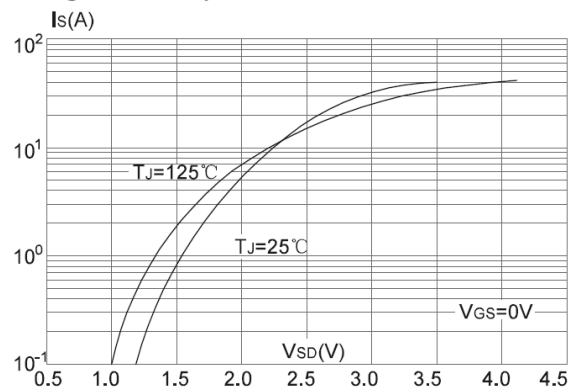

Figure 5: Gate Charge Characteristics

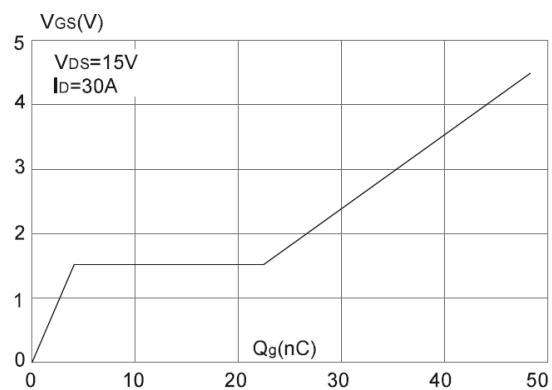

Figure 6: Capacitance Characteristics

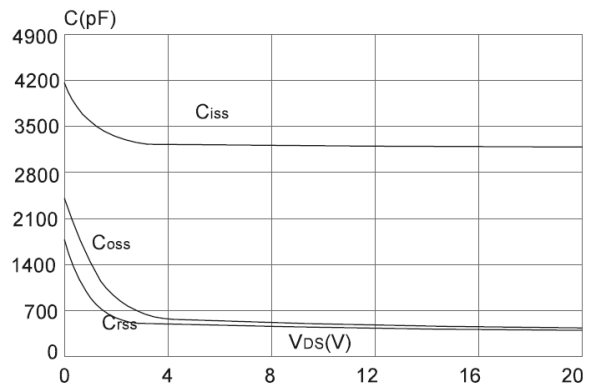

Figure 7: Normalized Breakdown Voltage vs. Junction Temperature

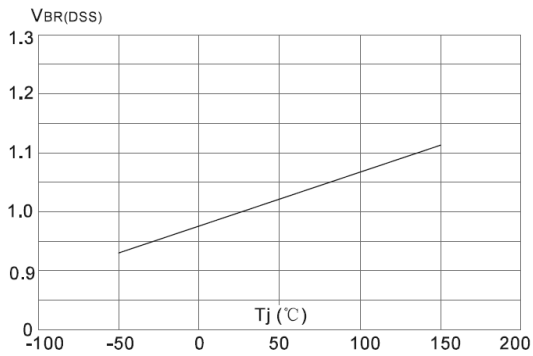

Figure 8: Normalized on Resistance vs. Junction Temperature

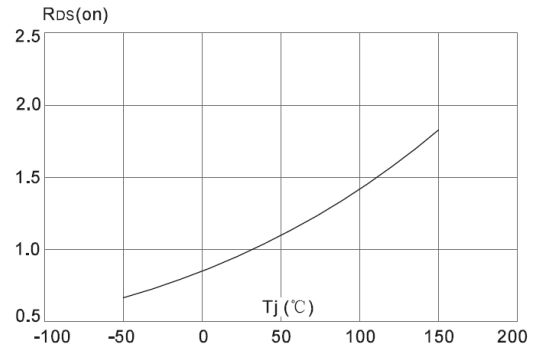

Figure 9: Maximum Drain Current vs. Case Temperature

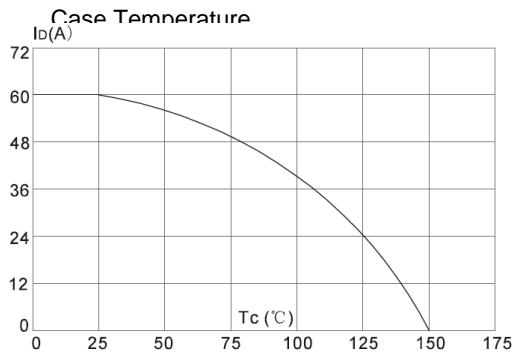

Fig.10 Safe Operating Area

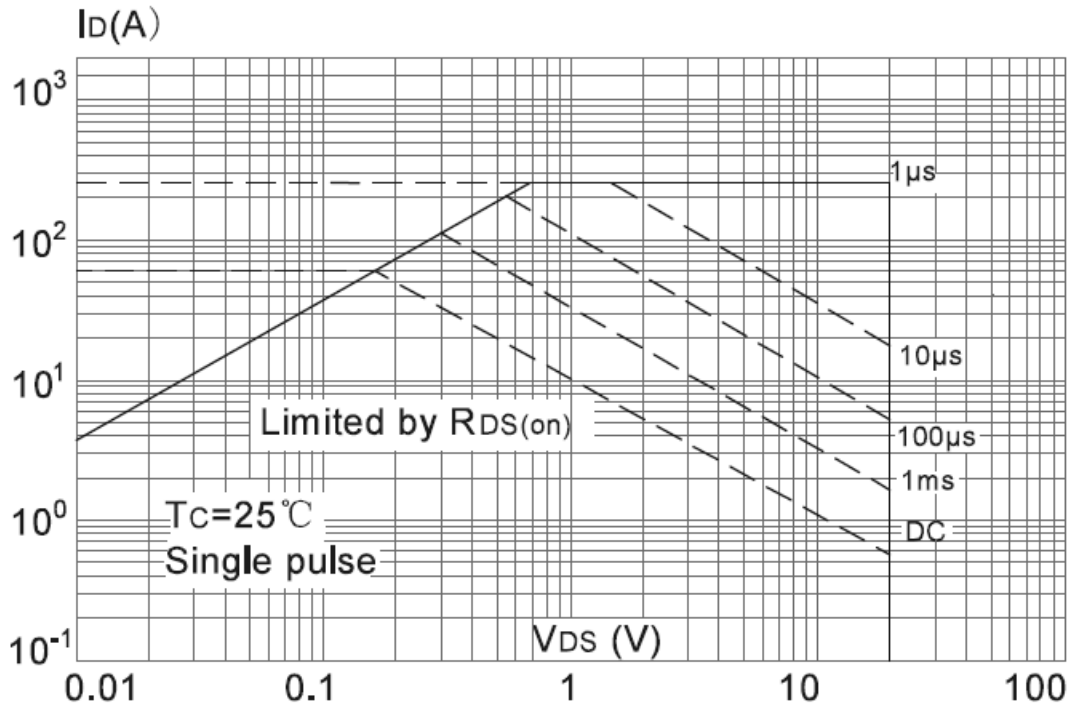
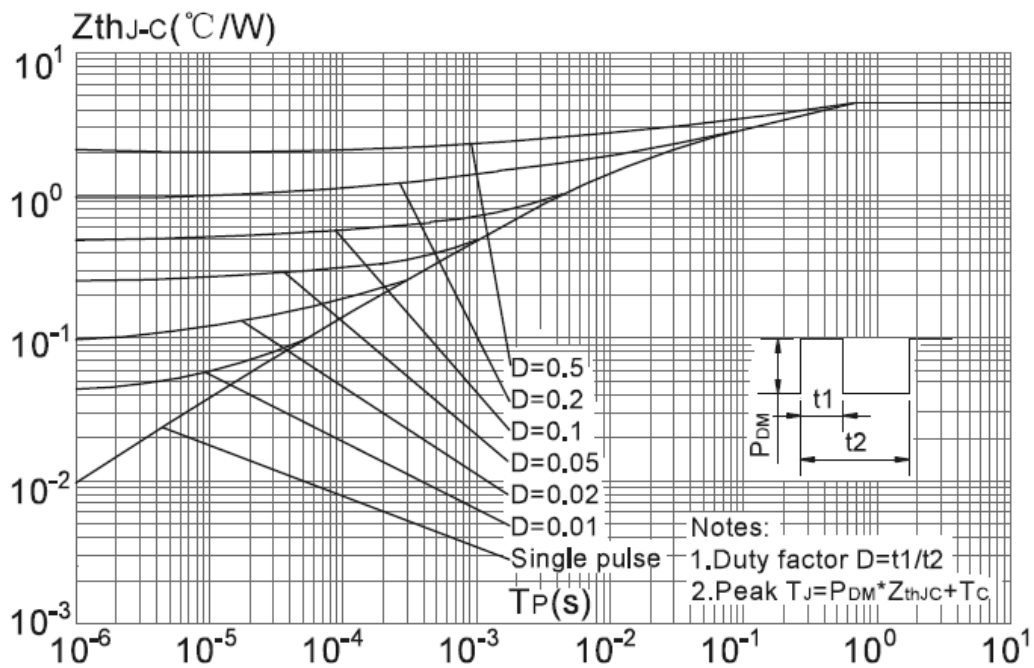
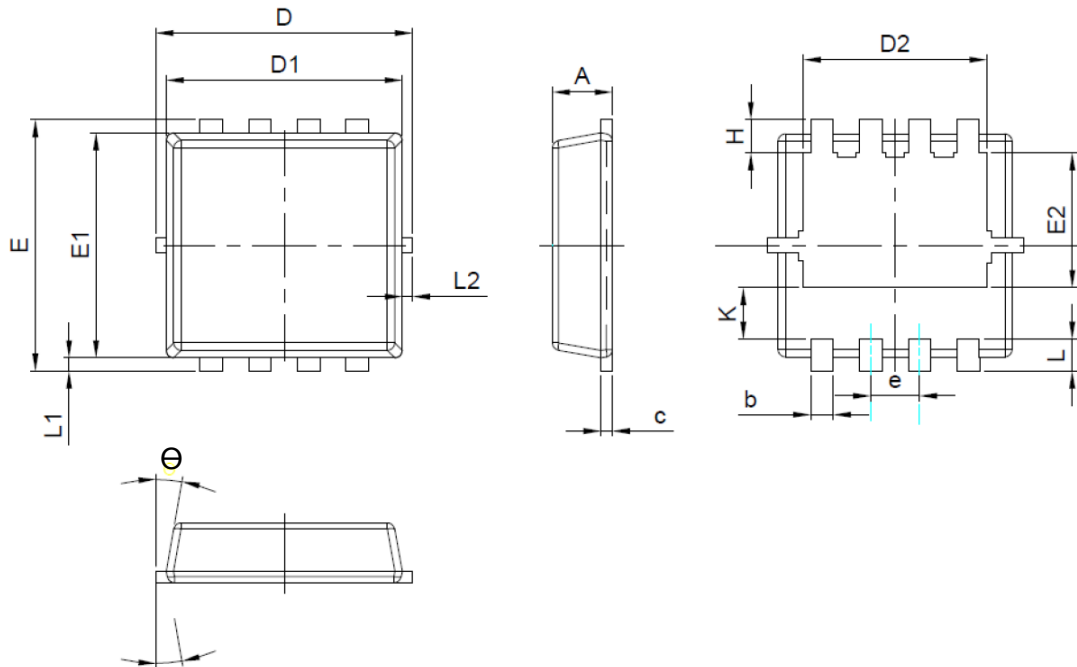

Fig. 11 Transient Thermal Response Curve



PDFN3X3-8L Package Information



COMMON DIMENSIONS
(UNITS OF MEASURE = MILLIMETER)

SYMBOL	MIN	NOM	MAX
A	0.70	0.80	0.90
b	0.25	0.30	0.39
c	0.14	0.15	0.25
D	3.20	3.30	3.40
D1	3.00	3.15	3.30
D2	2.35	2.45	2.55
e	0.65 BSC		
E	3.25	3.35	3.45
E1	2.85	3.00	3.15
E2	1.635	1.735	1.835
H	0.33	0.48	0.63
K	0.585	0.685	0.785
L	0.30	0.40	0.50
L1	0.05	0.15	0.25
L2	-	-	0.15
θ	8°	10°	12°

X-ON Electronics

Largest Supplier of Electrical and Electronic Components

Click to view similar products for [MOSFET](#) category:

Click to view products by [Quan Li](#) manufacturer:

Other Similar products are found below :

[IRFD120](#) [JANTX2N5237](#) [2SK2267\(Q\)](#) [BUK455-60A/B](#) [TK100A10N1,S4X\(S](#) [MIC4420CM-TR](#) [VN1206L](#) [NDP4060](#) [SI4482DY](#)
[IRS2092STRPBF-EL](#) [IPS70R2K0CEAKMA1](#) [SQM120N06-3M5L-GE3](#) [TK31J60W5,S1VQ\(O](#) [TK31J60W,S1VQ\(O](#) [TK16J60W,S1VQ\(O](#)
[2SK2614\(TE16L1,Q\)](#) [DMN1017UCP3-7](#) [EFC2J004NUZTDG](#) [P85W28HP2F-7071](#) [NTE2384](#) [DMC2700UDMQ-7](#) [DMN2080UCB4-7](#)
[DMN61D9UWQ-13](#) [US6M2GTR](#) [DMN31D5UDJ-7](#) [DMP22D4UFO-7B](#) [IPS60R3K4CEAKMA1](#) [DMN1006UCA6-7](#) [DMN16M9UCA6-7](#)
[STF5N65M6](#) [IRF40H233XTMA1](#) [STU5N65M6](#) [DMN6022SSD-13](#) [DMN13M9UCA6-7](#) [DMTH10H4M6SPS-13](#) [IPS60R360PFD7SAKMA1](#)
[DMN2990UFB-7B](#) [SSM3K35CT,L3F](#) [IPLK60R1K0PFD7ATMA1](#) [2N7002W-G](#) [MCAC30N06Y-TP](#) [IPWS65R035CFD7AXKSA1](#)
[MCQ7328-TP](#) [SSM3J143TU,LXHF](#) [PJMF280N65E1_T0_00201](#) [PJMF380N65E1_T0_00201](#) [PJMF280N60E1_T0_00201](#)
[PJMF600N65E1_T0_00201](#) [PJMF900N65E1_T0_00201](#) [PJMF900N60E1_T0_00201](#)