

AP3003

N and P-Channel Enhancement Mosfet

Feature

● N-Channel

$V_{DD}=30V, I_D=5.8A$

$R_{DS(on)} < 38m\Omega @ V_{GS}=4.5V \text{ Typ}=24m\Omega$

$R_{DS(on)} < 58m\Omega @ V_{GS}=2.5V \text{ Typ}=35m\Omega$

● P-Channel

$V_{DD}=-30V, I_D=-4.2A$

$R_{DS(on)} < 68m\Omega @ V_{GS}=-4.5V \text{ Typ}=53m\Omega$

$R_{DS(on)} < 96m\Omega @ V_{GS}=-2.5V \text{ Typ}=75m\Omega$

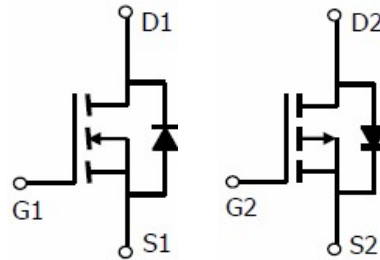

N-channel

P-channel

- Lead free product is acquired
- High power and current handling capability
- Surface mount package

Application

- Interfacing Switching
- Load Switching
- Power management

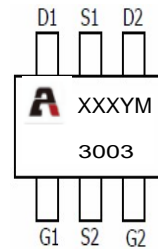

Marking and pin assignment

Package Marking and Ordering Information

Device Marking	Device	Device Package	Reel Size	Tape width	Quantity (PCS)
3003	AP3003	SOT23-6	-	-	3000

ABSOLUTE MAXIMUM RATINGS ($T_a=25^\circ\text{C}$ unless otherwise noted)

Parameter	Symbol	N-Channel	P-Channel	Unit
Drain-Source Voltage	V_{DS}	30	-30	V
Gate-Source Voltage	V_{GS}	± 12	± 12	V
Continuous Drain Current ($T_a = 25^\circ\text{C}$)	I_D	5.8	-4.2	A
Continuous Drain Current ($T_a = 100^\circ\text{C}$)	I_D	3.6	-2.6	A
Pulsed Drain Current ⁽¹⁾	I_{DM}	23	-16.8	A
Power Dissipation	P_D	1.7	1.7	W
Thermal Resistance from Junction to Ambient	$R_{\theta JA}$	74	74	$^\circ\text{C/W}$
Junction Temperature	T_J	150	150	$^\circ\text{C}$
Storage Temperature	T_{STG}	-55~ +150	-55~ +150	$^\circ\text{C}$

N-CH ELECTRICAL CHARACTERISTICS(T_a=25°C unless otherwise noted)

Parameter	Symbol	Test Condition	Min	Type	Max	Unit
Static Characteristics						
Drain-source breakdown voltage	V _{(BR)DSS}	V _{GS} = 0V, I _D =250μA	30	-	-	V
Zero gate voltage drain current	I _{DSS}	V _{DS} =30V, V _{GS} = 0V	-	-	1	μA
Gate-body leakage current	I _{GSS}	V _{GS} =±12V, V _{DS} = 0V	-	-	±100	nA
Gate threshold voltage ⁽³⁾	V _{GS(th)}	V _{DS} =V _{GS} , I _D =250μA	0.4	1.0	1.5	V
Drain-source on-resistance ⁽³⁾	R _{DS(on)}	V _{GS} =4.5V, I _D =5A	-	24	38	mΩ
		V _{GS} =2.5V, I _D =1A	-	35	58	
Dynamic characteristics						
Input Capacitance	C _{iss}	V _{DS} =15V, V _{GS} =0V, f =1MHz	-	700	-	pF
Output Capacitance	C _{oss}		-	66	-	
Reverse Transfer Capacitance	C _{rss}		-	52	-	
Switching characteristics						
Turn-on delay time	t _{d(on)}	V _{DD} =15V, I _D =4.0A, V _{GS} =4.5V, R _G =10Ω	-	12	-	ns
Turn-on rise time	t _r		-	52	-	
Turn-off delay time	t _{d(off)}		-	17	-	
Turn-off fall time	t _f		-	10	-	
Total Gate Charge	Q _g	V _{DS} =15V, I _D =4.0A, V _{GS} =4.5V	-	4.8	-	nC
Gate-Source Charge	Q _{gs}		-	1.2	-	
Gate-Drain Charge	Q _{gd}		-	1.7	-	
Source-Drain Diode characteristics						
Diode Forward voltage ⁽³⁾	V _{DS}	V _{GS} =0V, I _S =5.8A	-	-	1.2	V
Diode Forward current ⁽⁴⁾	I _S		-	-	5.8	A

Notes:

1. Repetitive Rating: pulse width limited by maximum junction temperature
2. Pulse Test: pulse width≤300μs, duty cycle≤2%
3. Surface Mounted on FR4 Board, t≤10 sec

P-CH ELECTRICAL CHARACTERISTICS(T_a=25°C unless otherwise noted)

Parameter	Symbol	Test Condition	Min	Type	Max	Unit
Static Characteristics						
Drain-source breakdown voltage	V _{(BR)DSS}	V _{GS} = 0V, I _D = -250μA	-30			V
Zero gate voltage drain current	I _{DSS}	V _{DS} = -30V, V _{GS} = 0V			-1	μA
Gate-body leakage current	I _{GSS}	V _{GS} = ±12V, V _{DS} = 0V			±100	nA
Gate threshold voltage ⁽²⁾	V _{GS(th)}	V _{DS} = V _{GS} , I _D = -250μA	-0.5	-0.9	-1.3	V
Drain-source on-resistance ⁽²⁾	R _{DS(on)}	V _{GS} = -4.5V, I _D = -4A		53	68	mΩ
		V _{GS} = -2.5V, I _D = -1A		75	96	
Dynamic characteristics						
Input Capacitance	C _{iss}	V _{DS} = -15V, V _{GS} = 0V, f = 1MHz		882		pF
Output Capacitance	C _{oss}			104		
Reverse Transfer Capacitance	C _{rss}			65		
Switching characteristics						
Turn-on delay time	t _{d(on)}	V _{DD} = -15V, I _D = -1.0A, V _{GS} = -10V, R _G = 2.5Ω		7		ns
Turn-on rise time	t _r			3		
Turn-off delay time	t _{d(off)}			20		
Turn-off fall time	t _f			12		
Total Gate Charge	Q _g	V _{DS} = -15V, I _D = -4.2A, V _{GS} = -10V		8.5		nC
Gate-Source Charge	Q _{gs}			1.8		
Gate-Drain Charge	Q _{gd}			2.7		
Source-Drain Diode characteristics						
Diode Forward voltage ⁽²⁾	V _{DS}	V _{GS} = 0V, I _S = -4.2A			1.2	V
Diode Forward current ⁽³⁾	I _S		-	-	-4.2	A

Notes:

1. Repetitive Rating: pulse width limited by maximum junction temperature
2. Pulse Test: pulse width ≤ 300μs, duty cycle ≤ 2%
3. Surface Mounted on FR4 Board, t ≤ 10 sec

N-Channel

Test Circuit

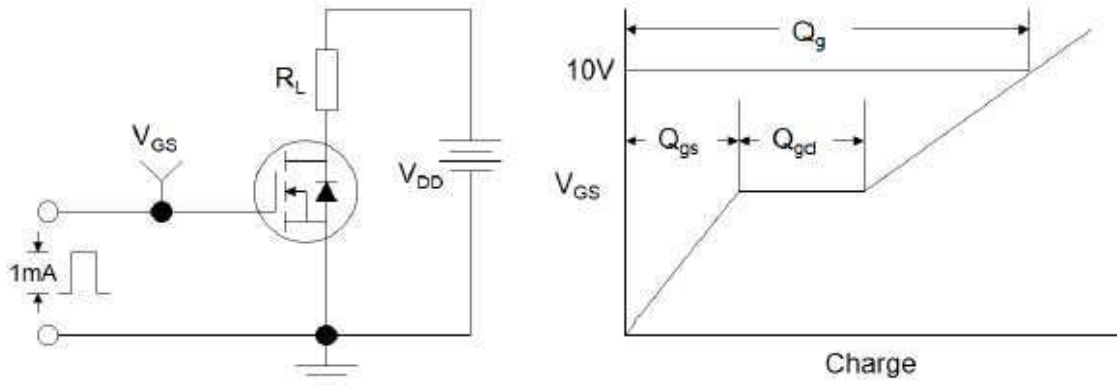

Figure1:Gate Charge Test Circuit & Waveform

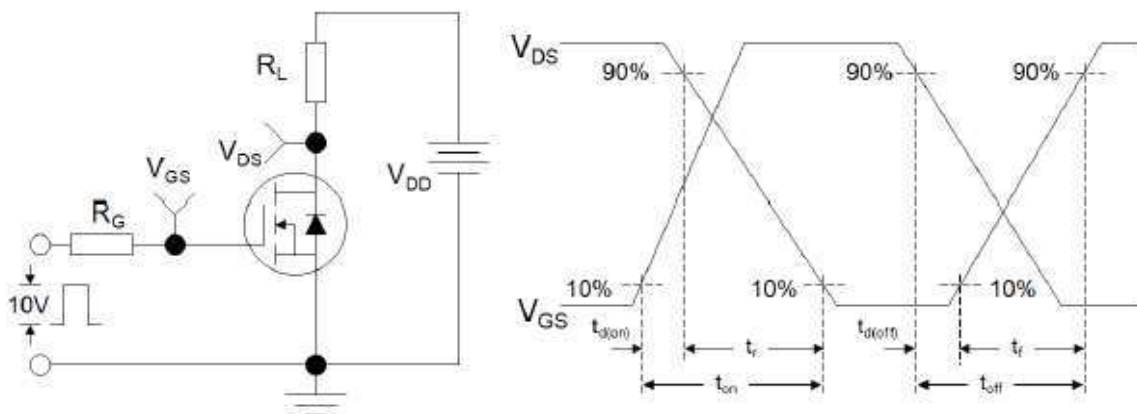

Figure 2: Resistive Switching Test Circuit & Waveforms

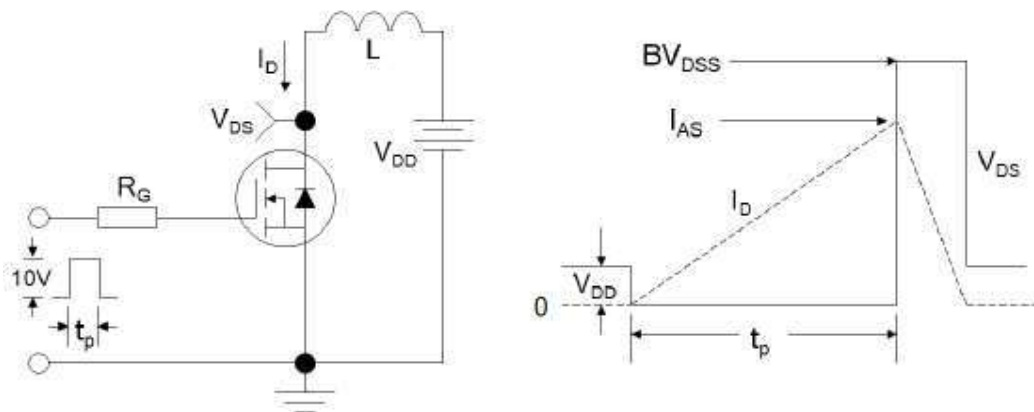

Figure 3:Unclamped Inductive Switching Test Circuit & Waveforms

N-Channel

Figure 1: Output Characteristics

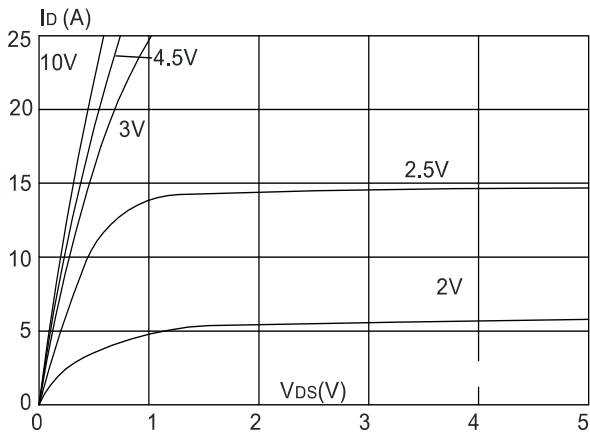

Figure 2: Typical Transfer Characteristics

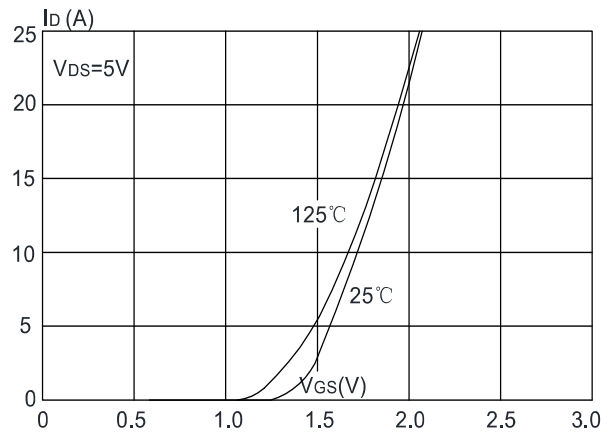

Figure 3: On-resistance vs. Drain Current

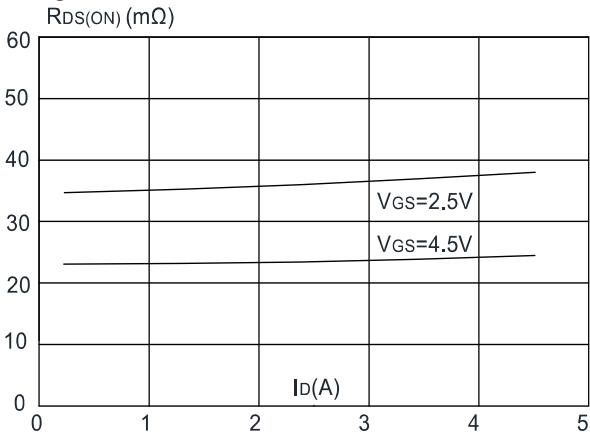

Figure 4: Body Diode Characteristics

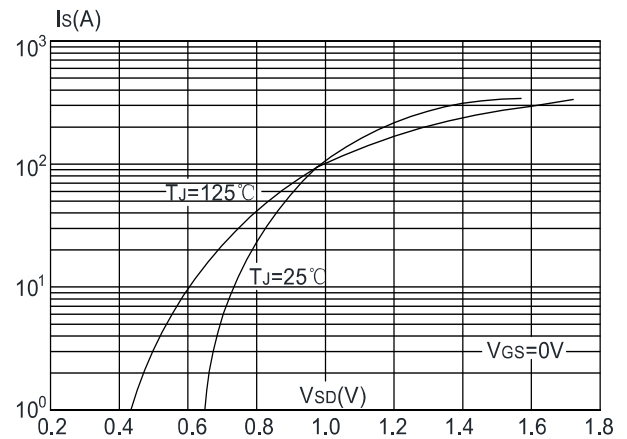

Figure 5: Gate Charge Characteristics

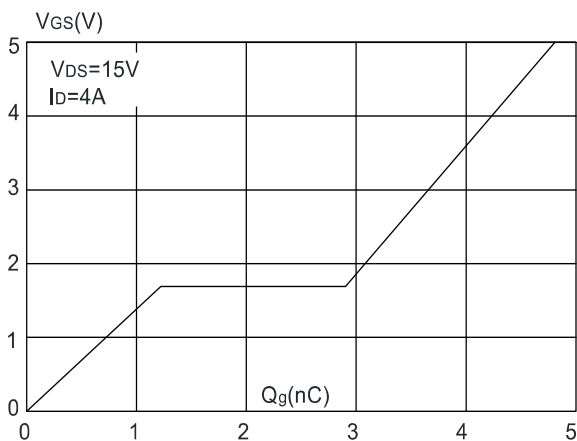
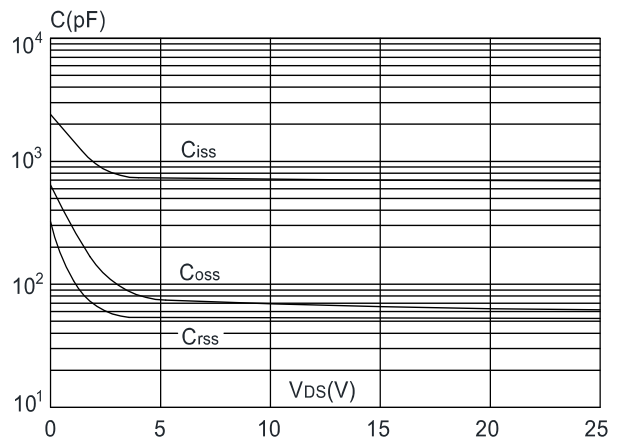

Figure 6: Capacitance Characteristics



N-Channel

Figure 7: Normalized Breakdown Voltage vs. Junction Temperature

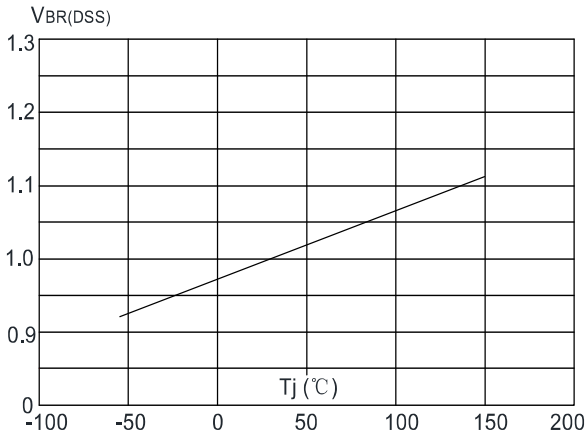

Figure 8: Normalized on Resistance vs. Junction Temperature

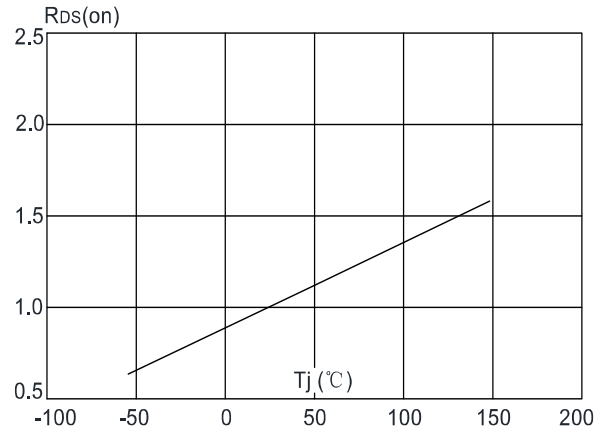

Figure 9: Maximum Safe Operating Area

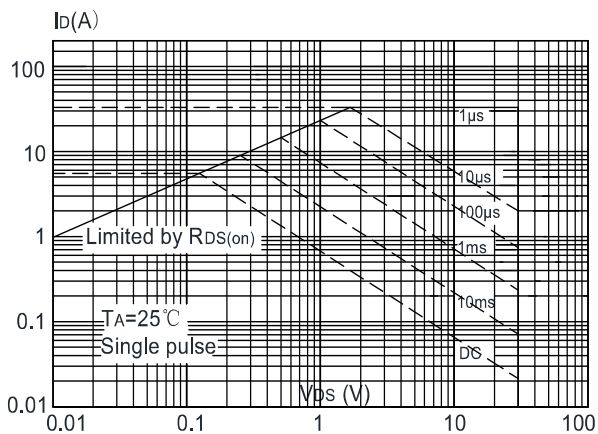

Figure 10: Maximum Continuous Drain Current vs. Ambient Temperature

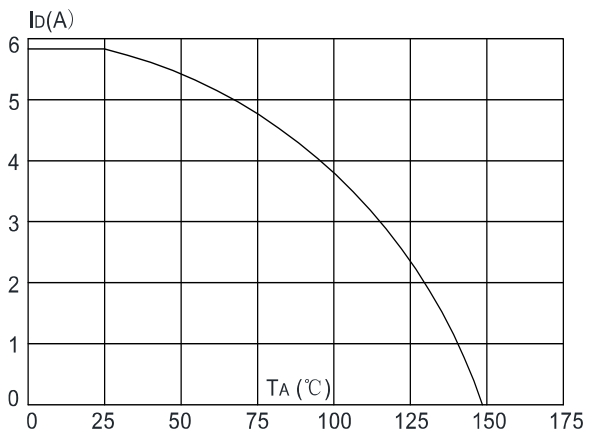
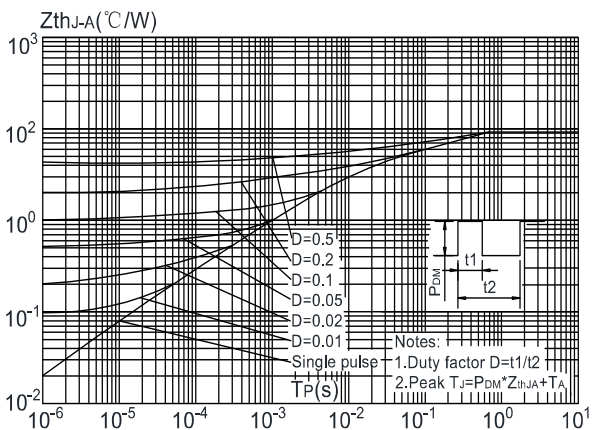

Figure.11: Maximum Effective Transient Thermal Impedance, Junction-to-Ambient



P-Channel

Test Circuit & Waveform

Gate Charge Test Circuit & Waveform

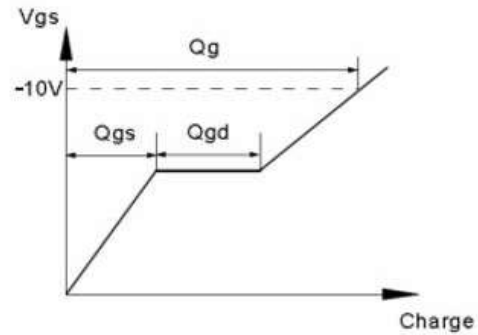
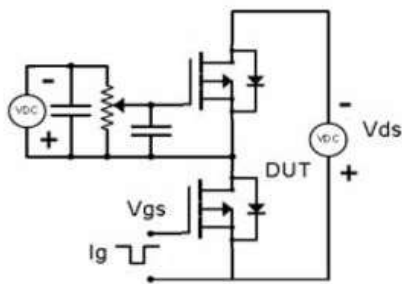

Resistive Switching Test Circuit & Waveforms

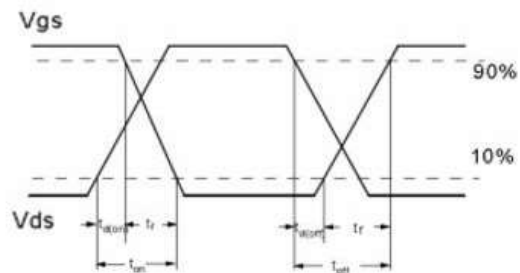
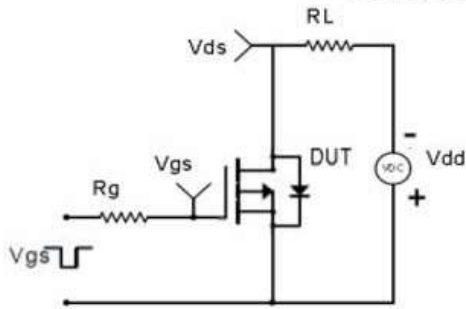

Unclamped Inductive Switching (UIS) Test Circuit & Waveforms

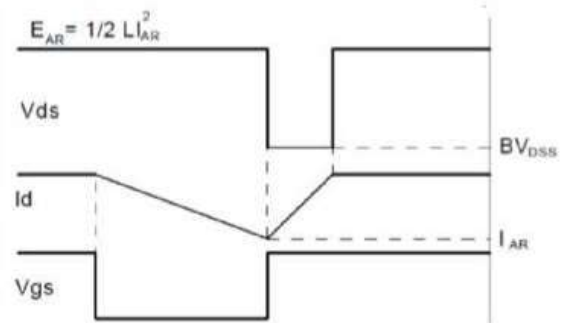
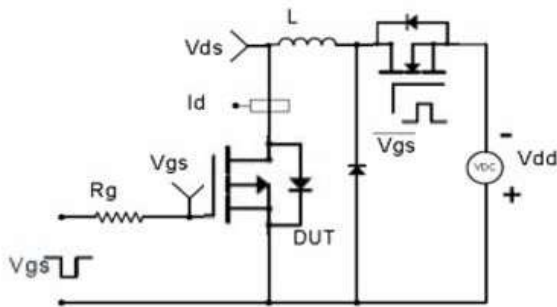

Diode Recovery Test Circuit & Waveforms

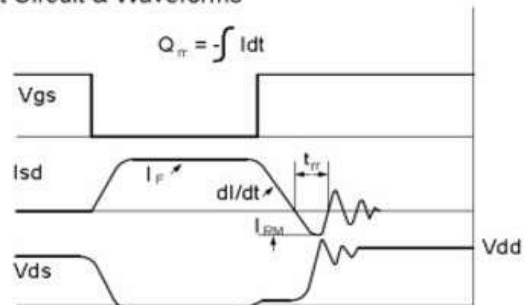
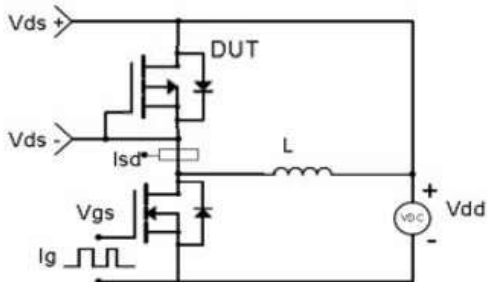

P-Channel

Figure 1: Output Characteristics

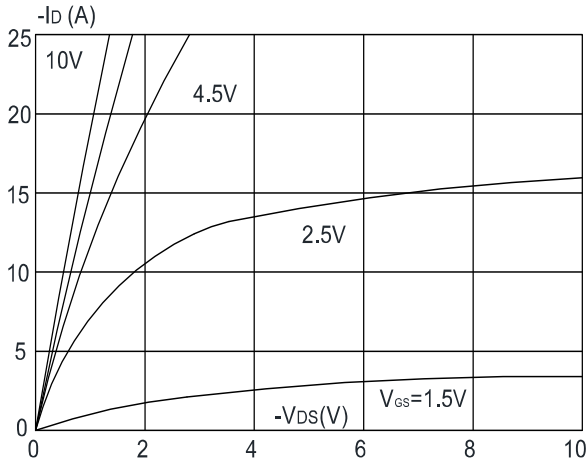

Figure 2: Typical Transfer Characteristics

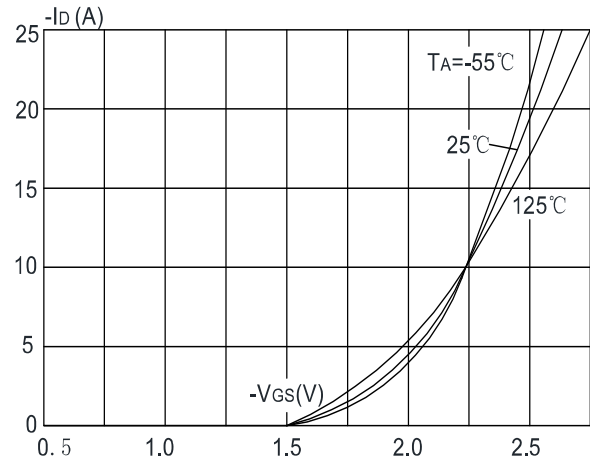

Figure 3: On-resistance vs. Drain Current

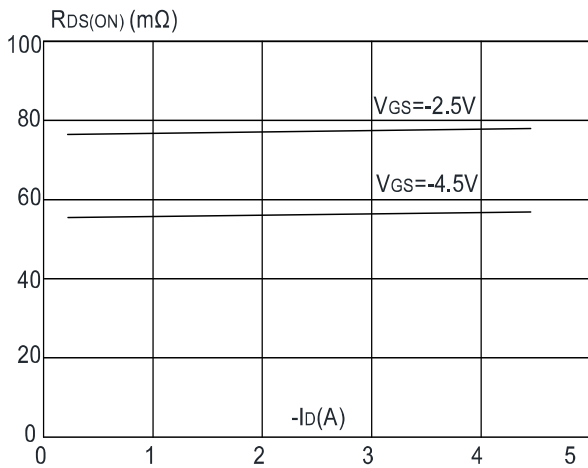

Figure 4: Body Diode Characteristics

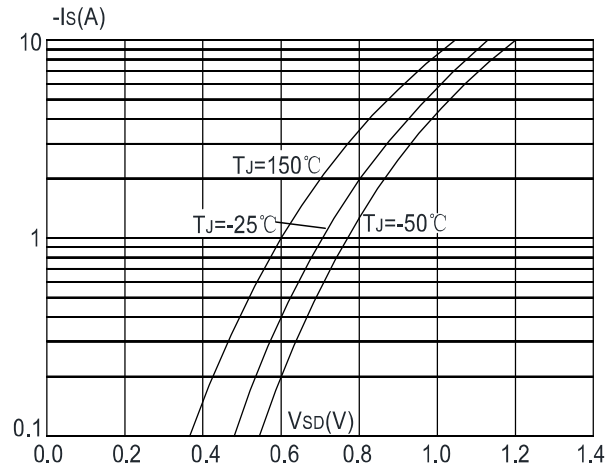

Figure 5: Gate Charge Characteristics

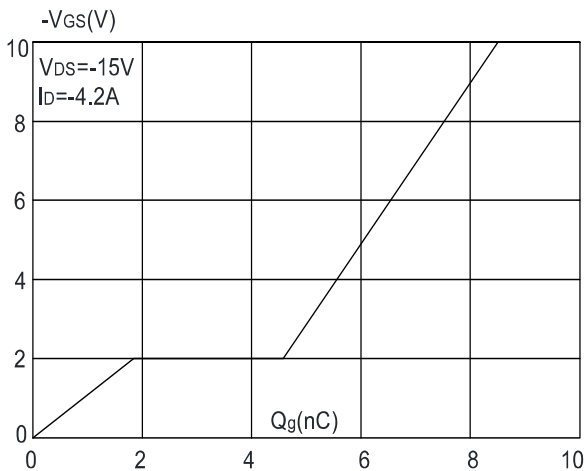
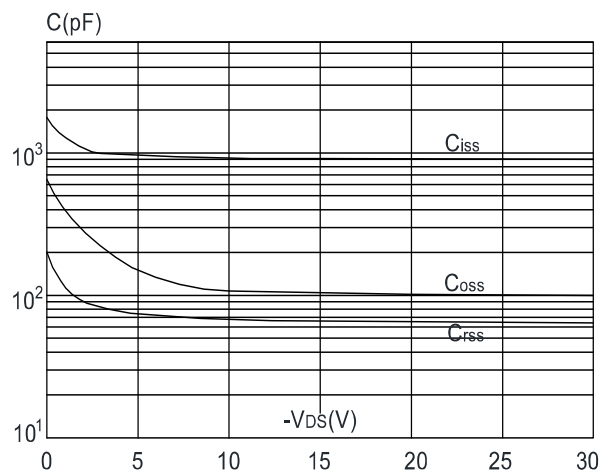

Figure 6: Capacitance Characteristics



P-Channel

Figure 7: Normalized Breakdown Voltage vs. Junction Temperature

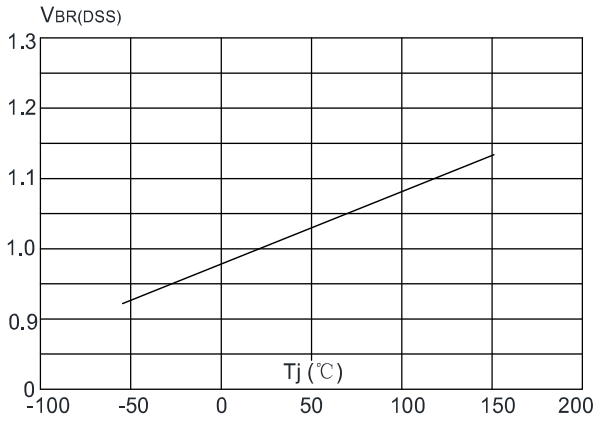

Figure 8: Normalized on Resistance vs. Junction Temperature

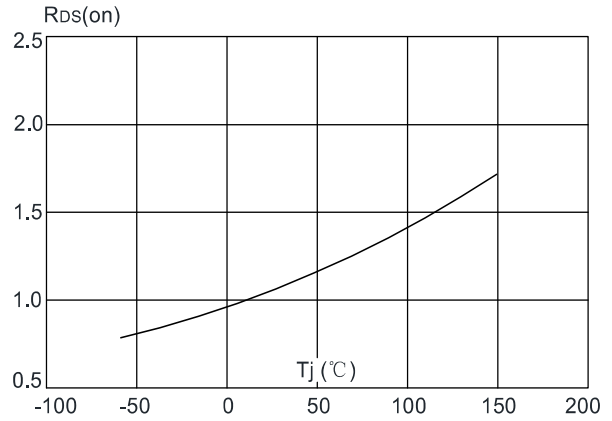

Figure 9: Maximum Safe Operating Area

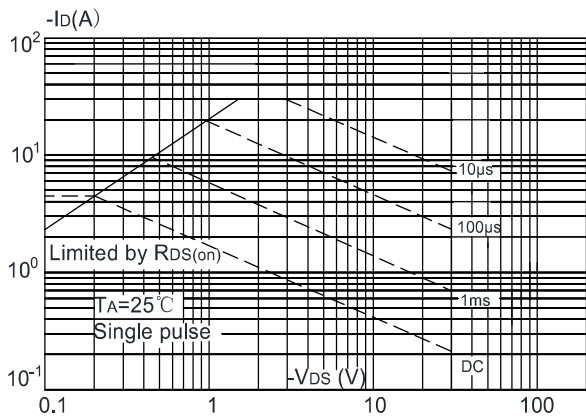

Figure 10: Maximum Continuous Drain Current vs. Ambient Temperature

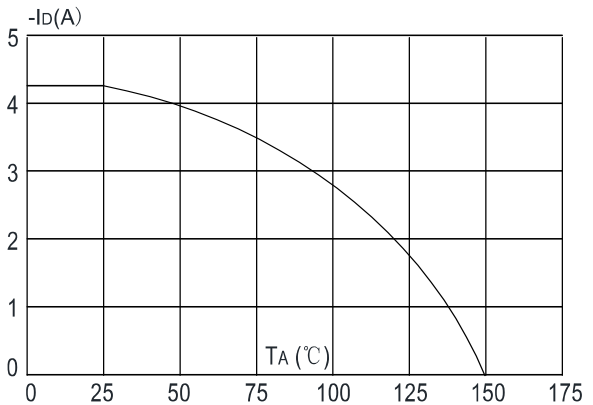
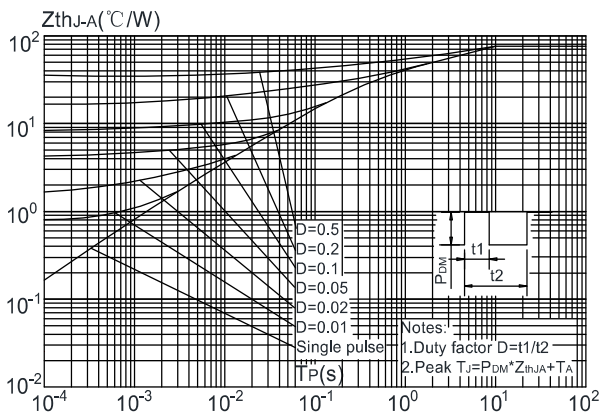
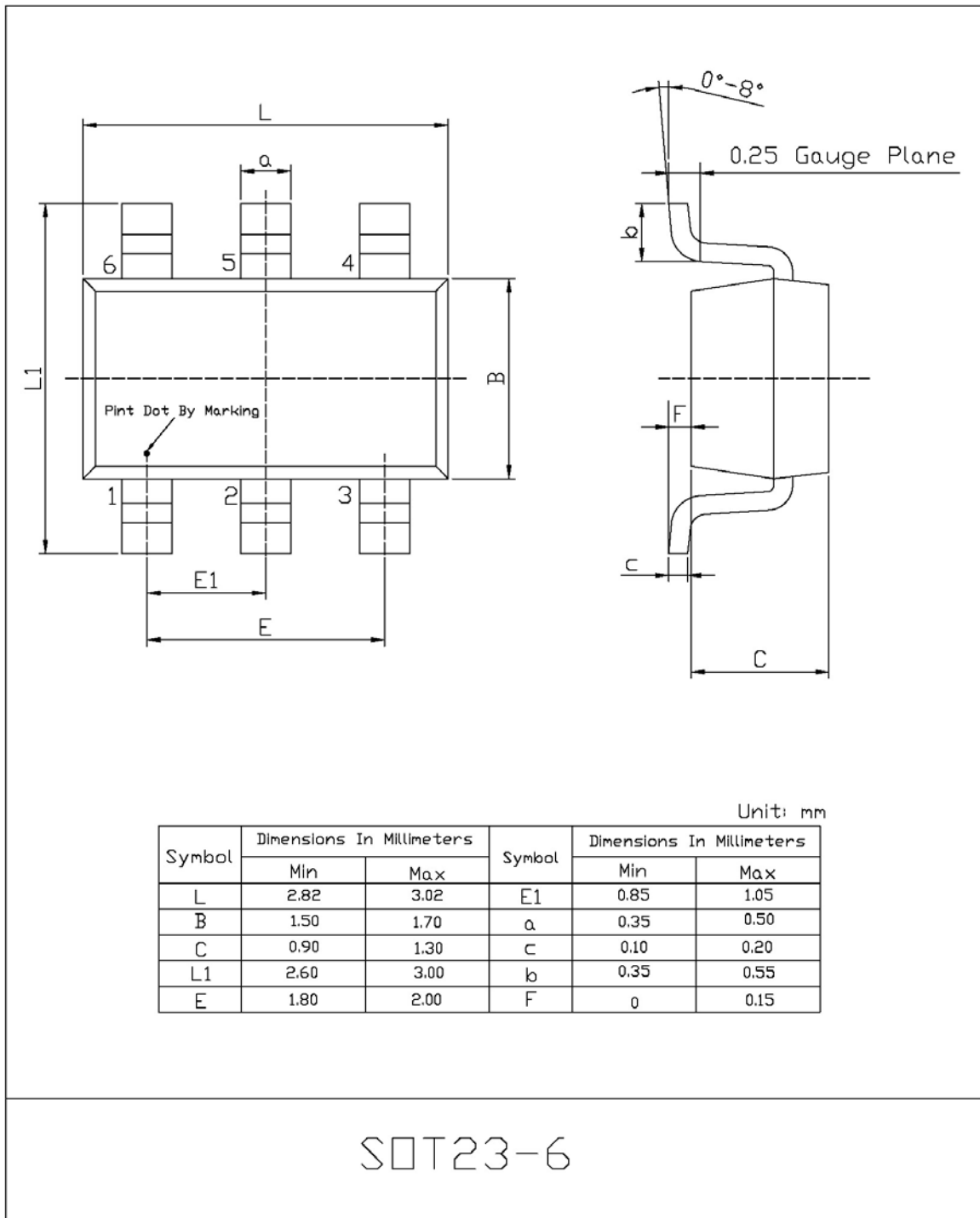

Figure.11: Maximum Effective Transient Thermal Impedance, Junction-to-Ambient



SOT23-6 Package Information



Revision History

Revision	Release	Remark
V1.0	2023/03/17	Initial Release

Disclaimer

The information given in this document describes the independent performance of the product, but similar performance is not guaranteed under other working conditions, and cannot be guaranteed when installed with other products or equipment. To achieve the required performance of the product in actual scenarios, the customer should conduct a complete application test to assess the functionality of the product.

Allpower assumes no responsibility for equipment failures result from using products at values that exceed the ratings, operating conditions, or other parameters listed in the product specifications.

The product described in this specification is not applicable for aerospace or other applications which requires high reliability. Customers using or selling these products for use in medical, life-saving, or life-sustaining applications do so at their own risk and agree to fully indemnify.

Due to product or technical improvements, the information described or contained herein may be changed without prior notice.

X-ON Electronics

Largest Supplier of Electrical and Electronic Components

Click to view similar products for [MOSFET](#) category:

Click to view products by [Quan Li](#) manufacturer:

Other Similar products are found below :

[IRFD120](#) [JANTX2N5237](#) [2SK2267\(Q\)](#) [BUK455-60A/B](#) [TK100A10N1,S4X\(S](#) [MIC4420CM-TR](#) [VN1206L](#) [NDP4060](#) [SI4482DY](#)
[IRS2092STRPBF-EL](#) [IPS70R2K0CEAKMA1](#) [TK31J60W5,S1VQ\(O](#) [TK31J60W,S1VQ\(O](#) [TK16J60W,S1VQ\(O](#) [2SK2614\(TE16L1,Q\)](#)
[DMN1017UCP3-7](#) [EFC2J004NUZTDG](#) [P85W28HP2F-7071](#) [DMN1053UCP4-7](#) [NTE2384](#) [DMC2700UDMQ-7](#) [DMN2080UCB4-7](#)
[DMN61D9UWQ-13](#) [US6M2GTR](#) [DMN31D5UDJ-7](#) [DMP22D4UFO-7B](#) [IPS60R3K4CEAKMA1](#) [DMN1006UCA6-7](#) [DMN16M9UCA6-7](#)
[STF5N65M6](#) [IRF40H233XTMA1](#) [STU5N65M6](#) [DMN6022SSD-13](#) [DMN13M9UCA6-7](#) [DMTH10H4M6SPS-13](#) [IPS60R360PFD7SAKMA1](#)
[DMN2990UFB-7B](#) [SSM3K35CT,L3F](#) [IPLK60R1K0PFD7ATMA1](#) [2N7002W-G](#) [MCAC30N06Y-TP](#) [IPWS65R035CFD7AXKSA1](#)
[MCQ7328-TP](#) [SSM3J143TU,LXHF](#) [PJMF280N65E1_T0_00201](#) [PJMF380N65E1_T0_00201](#) [PJMF280N60E1_T0_00201](#)
[PJMF600N65E1_T0_00201](#) [PJMF900N65E1_T0_00201](#) [PJMF900N60E1_T0_00201](#)