

N+P-Channel Enhancement Mode Power MOSFET

Description

The AP4813K uses advanced trench technology and design to provide excellent $R_{DS(ON)}$ with low gate charge. It can be used in a wide variety of applications.

General Features

N channel

- $V_{DS} = 30V, I_D = 18A$
 $R_{DS(ON)} < 24m\Omega @ V_{GS} = 10V$
 $R_{DS(ON)} < 36m\Omega @ V_{GS} = 4.5V$

p channel

- $V_{DS} = -30V, I_D = -13A$
 $R_{DS(ON)} < 60m\Omega @ V_{GS} = -10V$
 $R_{DS(ON)} < 85m\Omega @ V_{GS} = -4.5V$
- High density cell design for ultra low R_{dson}
- Fully characterized avalanche voltage and current
- Good stability and uniformity with high E_{AS}
- Excellent package for good heat dissipation
- Special process technology for high ESD capability

Application

- H-bridge
- Inverters

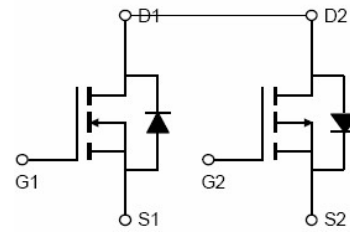

Schematic diagram

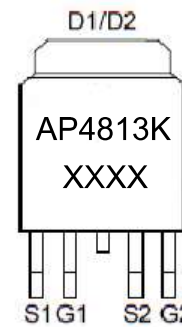

Marking and pin assignment

Package Marking and Ordering Information

Device Marking	Device	Device Package	Reel Size	Tape width	Quantity
AP4813K	AP4813K	TO-252-4L	-	-	-

Absolute Maximum Ratings ($T_C = 25^\circ C$ unless otherwise noted)

Parameter	Symbol	N-Channel	P-Channel	Unit	
Drain-Source Voltage	V_{DS}	30	-30	V	
Gate-Source Voltage	V_{GS}	± 20	± 20	V	
Continuous Drain Current	I_D	$T_C = 25^\circ C$	18	-13	A
		$T_C = 100^\circ C$	12.2	-9.6	
Pulsed Drain Current ^(Note 1)	I_{DM}	36	-26	A	
Maximum Power Dissipation	P_D	21		W	
Operating Junction and Storage Temperature Range	T_J, T_{STG}	-55 To 150		$^\circ C$	

Thermal Characteristic

Thermal Resistance, Junction-to-Case ^(Note 2)	$R_{\theta JC}$	7	$^\circ C/W$
--	-----------------	---	--------------

N-Channel Electrical Characteristics (T_C=25°C unless otherwise noted)

Parameter	Symbol	Condition	Min	Typ	Max	Unit
Off Characteristics						
Drain-Source Breakdown Voltage	BV _{DSS}	V _{GS} =0V I _D =250μA	30	-	-	V
Zero Gate Voltage Drain Current	I _{DSS}	V _{DS} =30V, V _{GS} =0V	-	-	1	μA
Gate-Body Leakage Current	I _{GSS}	V _{GS} =±20V, V _{DS} =0V	-	-	±100	nA
On Characteristics (Note 3)						
Gate Threshold Voltage	V _{GS(th)}	V _{DS} =V _{GS} , I _D =250μA	1.0	1.6	2.5	V
Drain-Source On-State Resistance	R _{DS(on)}	V _{GS} =10V, I _D =9A	-	20	24	mΩ
		V _{GS} =4.5V, I _D =6A	-	31.5	36	mΩ
Forward Transconductance	g _{FS}	V _{DS} =10V, I _D =9A	8.5	-	-	S
Dynamic Characteristics (Note 4)						
Input Capacitance	C _{iss}	V _{DS} =15V, V _{GS} =0V, F=1.0MHz	-	345	-	PF
Output Capacitance	C _{oss}		-	55	-	PF
Reverse Transfer Capacitance	C _{rss}		-	32	-	PF
Switching Characteristics (Note 4)						
Turn-on Delay Time	t _{d(on)}	V _{DD} =15V, R _L =2.5Ω V _{GS} =10V, R _G =3Ω	-	2.8	-	nS
Turn-on Rise Time	t _r		-	7.2	-	nS
Turn-Off Delay Time	t _{d(off)}		-	15.8	-	nS
Turn-Off Fall Time	t _f		-	4.6	-	nS
Total Gate Charge	Q _g	V _{DS} =15V, I _D =6A, V _{GS} =10V	-	9.5	-	nC
Gate-Source Charge	Q _{gs}		-	2.0	-	nC
Gate-Drain Charge	Q _{gd}		-	1.9	-	nC
Drain-Source Diode Characteristics						
Diode Forward Voltage (Note 3)	V _{SD}	V _{GS} =0V, I _S =25A	-	-	1.2	V
Diode Forward Current (Note 2)	I _S		-	-	18	A

Notes:

1. Repetitive Rating: Pulse width limited by maximum junction temperature.
2. Surface Mounted on FR4 Board, t ≤ 10 sec.
3. Pulse Test: Pulse Width ≤ 300μs, Duty Cycle ≤ 2%.
4. Guaranteed by design, not subject to production
5. EAS condition: T_J=25°C, V_{DD}=30V, V_G=10V, L=0.5mH, R_G=25Ω

电参数曲线图 / Electrical Characteristic Curve

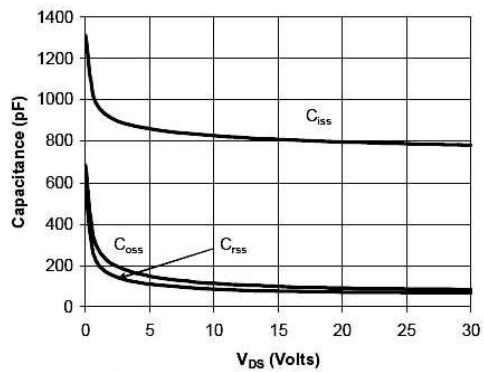
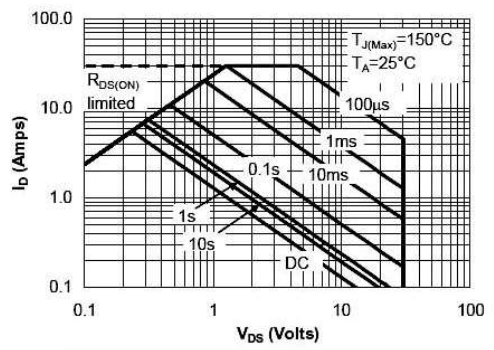
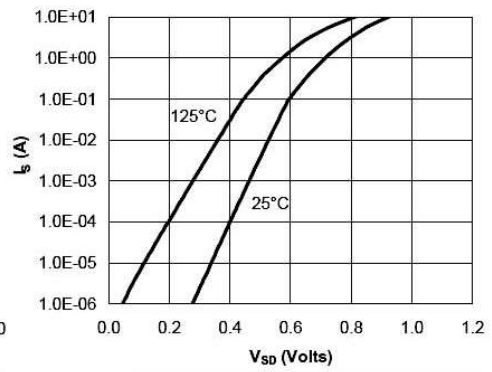
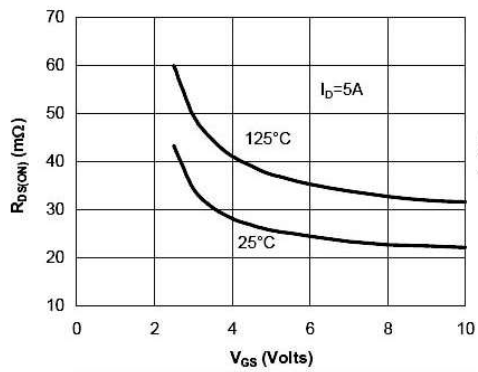
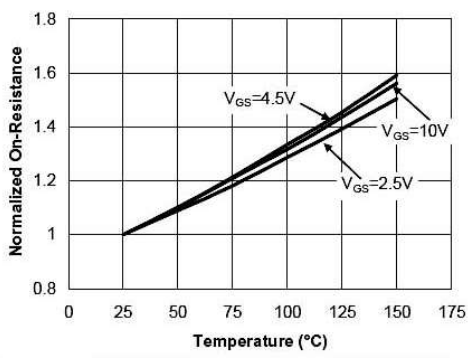
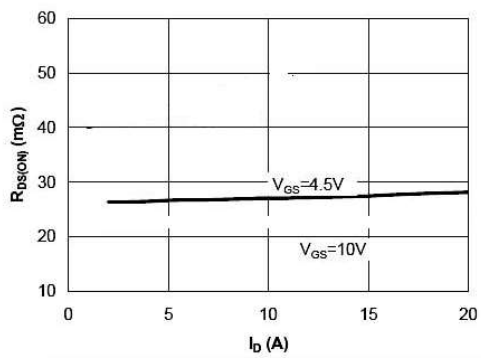
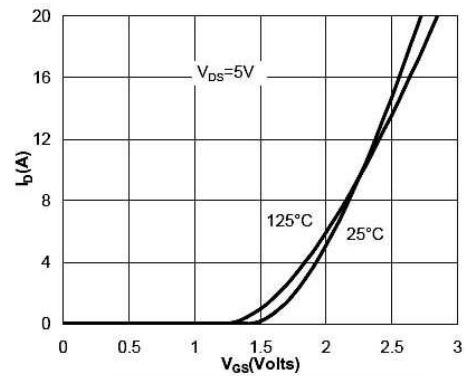
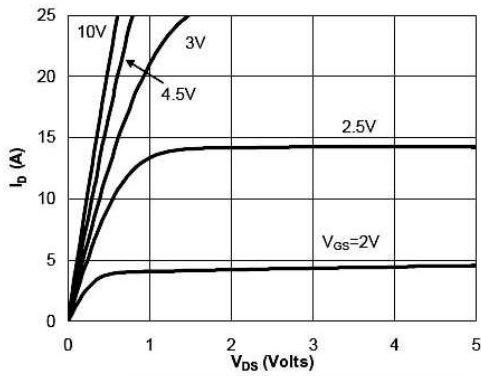

P-Channel Electrical Characteristics (T_C=25°C unless otherwise noted)

Parameter	Symbol	Condition	Min	Typ	Max	Unit
Off Characteristics						
Drain-Source Breakdown Voltage	BV _{DSS}	V _{GS} =0V, I _D =-250μA	-30	-	-	V
Zero Gate Voltage Drain Current	I _{DSS}	V _{DS} =-30V, V _{GS} =0V	-	-	-1	μA
Gate-Body Leakage Current	I _{GSS}	V _{GS} =±20V, V _{DS} =0V	-	-	±100	nA
On Characteristics (Note 3)						
Gate Threshold Voltage	V _{GS(th)}	V _{DS} =V _{GS} , I _D =-250μA	-1.0	-1.4	-2.5	V
Drain-Source On-State Resistance	R _{DS(ON)}	V _{GS} =-10V, I _D =-6A	-	54	60	mΩ
		V _{GS} =-4.5V, I _D =-5A	-	75	85	
Forward Transconductance	g _{FS}	V _{DS} =-5V, I _D =-6A	-	8.2	-	S
Dynamic Characteristics (Note 4)						
Input Capacitance	C _{iss}	V _{DS} =-30V, V _{GS} =0V, F=1.0MHz	-	700	-	PF
Output Capacitance	C _{oss}		-	120	-	PF
Reverse Transfer Capacitance	C _{rss}		-	75	-	PF
Switching Characteristics (Note 4)						
Turn-on Delay Time	t _{d(on)}	V _{DD} =-15V, R _L =2.5Ω V _{GS} =-10V, R _G =3Ω	-	8.6	-	nS
Turn-on Rise Time	t _r		-	5	-	nS
Turn-Off Delay Time	t _{d(off)}		-	28.2	-	nS
Turn-Off Fall Time	t _f		-	13.5	-	nS
Total Gate Charge	Q _g	V _{DS} =-15V, I _D =-6A, V _{GS} =-10V	-	16.2	-	nC
Gate-Source Charge	Q _{gs}		-	2.9	-	nC
Gate-Drain Charge	Q _{gd}		-	3.6	-	nC
Drain-Source Diode Characteristics						
Diode Forward Voltage (Note 3)	V _{SD}	V _{GS} =0V, I _S =-6A	-	-	-1.2	V
Diode Forward Current (Note 2)	I _S		-	-	-13	A
Reverse Recovery Time	t _{rr}	T _J = 25°C, I _F = -6A di/dt = 100A/μs (Note 3)	-	23	-	nS
Reverse Recovery Charge	Q _{rr}		-	14	-	nC

电参数曲线图 / Electrical Characteristic Curve

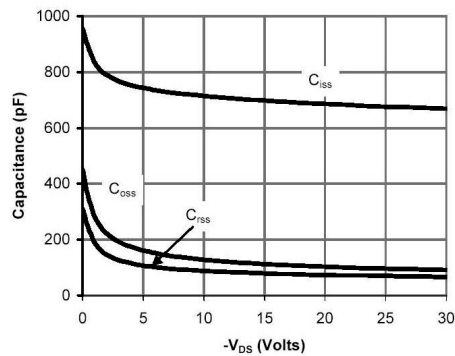
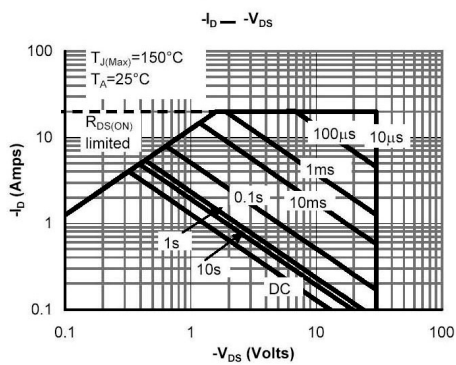
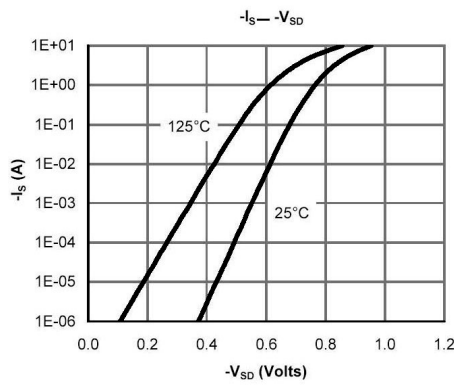
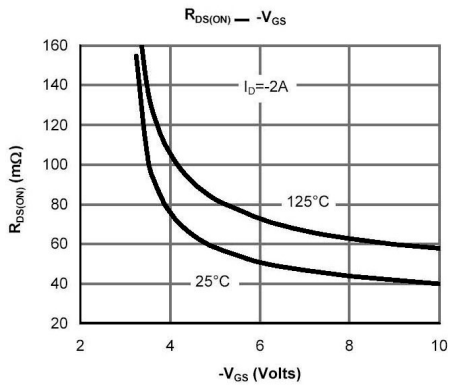
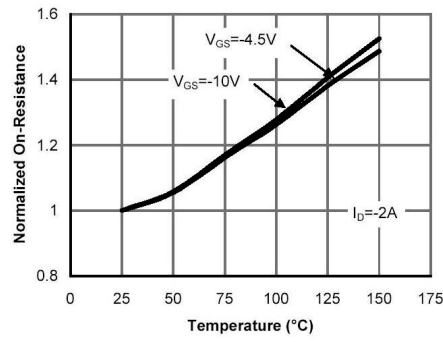
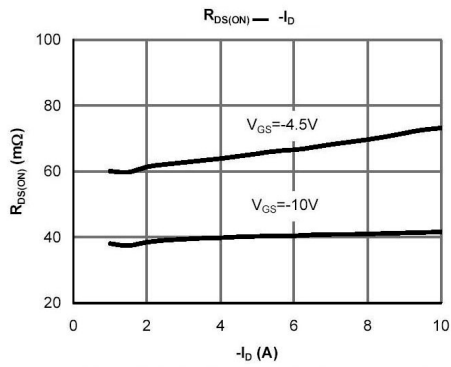
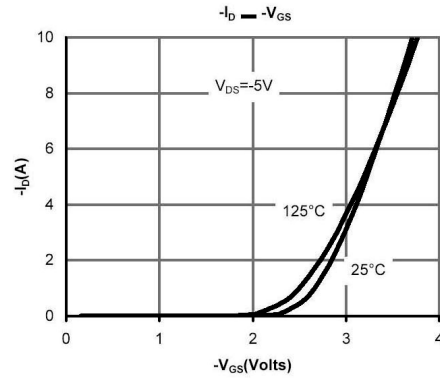
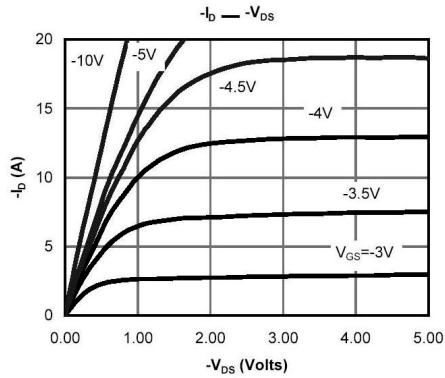

TO-252-4L Package Information

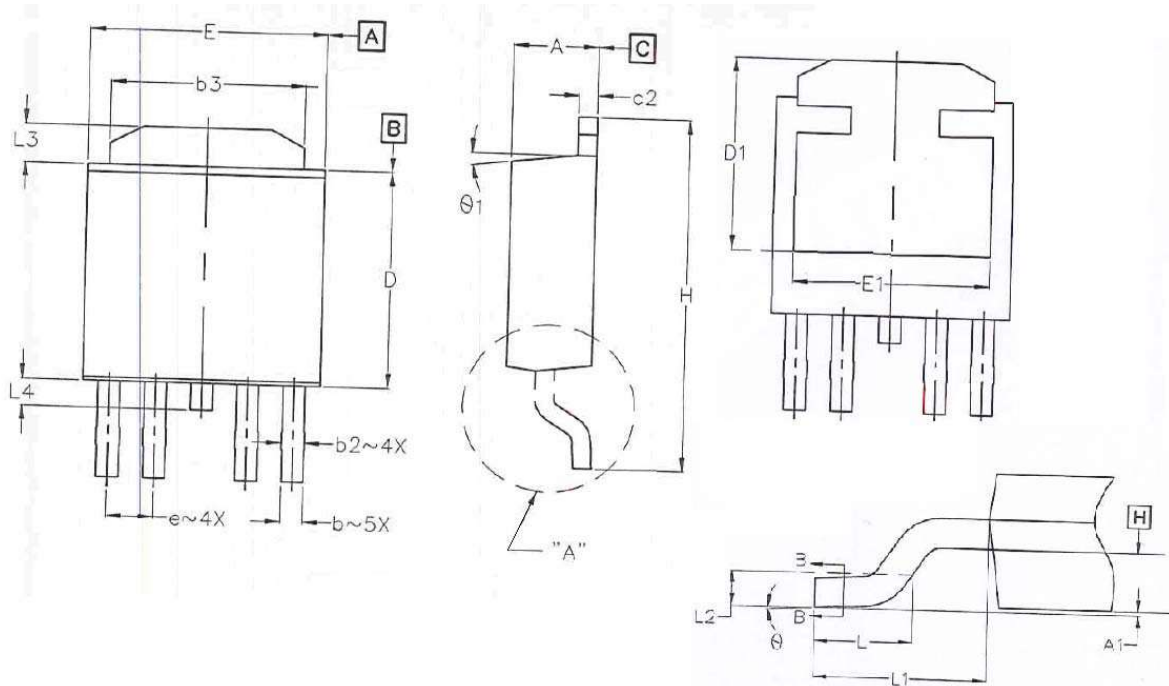

Symbol	Dimensions In Millimeters		Dimensions In Inches	
	Min.	Max.	Min.	Max.
A	2.184	2.387	0.086	0.094
A1	-	0.127	-	0.094
b	0.508	0.711	0.020	0.028
b1	0.508	0.660	0.020	0.026
b2	0.610	0.787	0.024	0.031
b3	4.953	5.461	0.195	0.215
c	0.460	0.610	0.018	0.024
c1	0.410	0.559	0.016	0.022
C2	0.460	12.950	0.498	0.510
D	4.980	5.180	0.196	0.204
D1	2.650	2.950	0.104	0.116
E	7.900	8.100	0.311	0.319
E1	0.000	0.300	0.000	0.012
e	12.900	13.400	0.508	0.528
H	2.850	3.250	0.112	0.128
L	1.397	1.778	0.055	0.070
L1	2.743	BSC	0.108	BSC
L2	0.508	BSC	0.020	BSC
L3	0.889	1.270	0.035	0.050
L4	-	1.015	-	0.040
theta	0°	10°	0°	10°
theta 1	0°	15°	0°	15°

X-ON Electronics

Largest Supplier of Electrical and Electronic Components

Click to view similar products for [MOSFET](#) category:

Click to view products by [Quan Li](#) manufacturer:

Other Similar products are found below :

[IRFD120](#) [JANTX2N5237](#) [2SK2267\(Q\)](#) [BUK455-60A/B](#) [TK100A10N1,S4X\(S](#) [MIC4420CM-TR](#) [VN1206L](#) [NDP4060](#) [SI4482DY](#)
[IRS2092STRPBF-EL](#) [IPS70R2K0CEAKMA1](#) [SQM120N06-3M5L-GE3](#) [TK31J60W5,S1VQ\(O](#) [TK31J60W,S1VQ\(O](#) [TK16J60W,S1VQ\(O](#)
[2SK2614\(TE16L1,Q\)](#) [DMN1017UCP3-7](#) [EFC2J004NUZTDG](#) [P85W28HP2F-7071](#) [NTE2384](#) [DMC2700UDMQ-7](#) [DMN2080UCB4-7](#)
[DMN61D9UWQ-13](#) [US6M2GTR](#) [DMN31D5UDJ-7](#) [DMP22D4UFO-7B](#) [IPS60R3K4CEAKMA1](#) [DMN1006UCA6-7](#) [DMN16M9UCA6-7](#)
[STF5N65M6](#) [IRF40H233XTMA1](#) [STU5N65M6](#) [DMN6022SSD-13](#) [DMN13M9UCA6-7](#) [DMTH10H4M6SPS-13](#) [IPS60R360PFD7SAKMA1](#)
[DMN2990UFB-7B](#) [SSM3K35CT,L3F](#) [IPLK60R1K0PFD7ATMA1](#) [2N7002W-G](#) [MCAC30N06Y-TP](#) [IPWS65R035CFD7AXKSA1](#)
[MCQ7328-TP](#) [SSM3J143TU,LXHF](#) [PJMF280N65E1_T0_00201](#) [PJMF380N65E1_T0_00201](#) [PJMF280N60E1_T0_00201](#)
[PJMF600N65E1_T0_00201](#) [PJMF900N65E1_T0_00201](#) [PJMF900N60E1_T0_00201](#)