

## Feature

- 40V,200A  
 $R_{DS(ON)} < 1.1m\Omega @ V_{GS}=10V$  (TYP:0.9m $\Omega$ )  
 $R_{DS(ON)} < 1.5m\Omega @ V_{GS}=4.5V$  (TYP:1.3m $\Omega$ )
- Split Gate Trench Technology
- Lead free product is acquired
- Excellent  $R_{DS(ON)}$  and Low Gate Charge

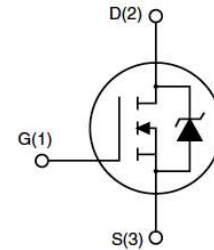

## Application

- PWM applications
- Load Switch
- Power management

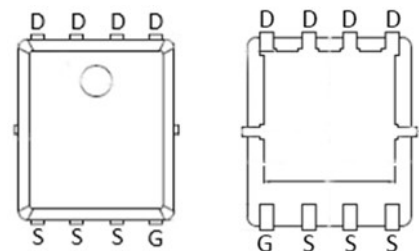

PDFN5X6

## Package Marking and Ordering Information

Device Marking	Device	Device Package	Reel Size	Tape width	Quantity (PCS)
G011N04	APG011N04G	PDFN5X6	13 inch	-	5000

## ABSOLUTE MAXIMUM RATINGS ( $T_a=25^\circ\text{C}$ unless otherwise noted)

Parameter	Symbol	Value	Unit
Drain-Source Voltage	$V_{DS}$	40	V
Gate-Source Voltage	$V_{GS}$	$\pm 20$	V
Continuous Drain Current ( $T_a=25^\circ\text{C}$ )	$I_D$	200	A
Continuous Drain Current ( $T_a=100^\circ\text{C}$ )	$I_D$	124	A
Pulsed Drain Current <sup>(1)</sup>	$I_{DM}$	560	A
Singel Pulsed Avalanche Energy <sup>(2)</sup>	$E_{AS}$	441	mJ
Power Dissipation	$P_D$	67.5	W
Thermal Resistance from Junction to Case	$R_{\theta JC}$	1.85	$^\circ\text{C}/\text{W}$
Junction Temperature	$T_J$	150	$^\circ\text{C}$
Storage Temperature	$T_{STG}$	-55~ +150	$^\circ\text{C}$

**MOSFET ELECTRICAL CHARACTERISTICS(T<sub>a</sub>=25°C unless otherwise noted)**

Parameter	Symbol	Test Condition	Min	Type	Max	Unit
<b>Static Characteristics</b>						
Drain-source breakdown voltage	V <sub>(BR)DSS</sub>	V <sub>GS</sub> = 0V, I <sub>D</sub> =250μA	40	-	-	V
Zero gate voltage drain current	I <sub>DSS</sub>	V <sub>DS</sub> =40V, V <sub>GS</sub> = 0V	-	-	1	μA
Gate-body leakage current	I <sub>GSS</sub>	V <sub>GS</sub> = ±20V, V <sub>DS</sub> = 0V	-	-	±100	nA
Gate threshold voltage <sup>(3)</sup>	V <sub>GS(th)</sub>	V <sub>DS</sub> =V <sub>GS</sub> , I <sub>D</sub> =250μA	1.2	1.7	2.2	V
Drain-source on-resistance <sup>(3)</sup>	R <sub>DS(on)</sub>	V <sub>GS</sub> =10V, I <sub>D</sub> =30A	-	0.9	1.1	mΩ
		V <sub>GS</sub> =4.5V, I <sub>D</sub> =30A	-	1.3	1.5	
Forward Threshold Voltage	g <sub>fs</sub>	V <sub>DS</sub> =2V, I <sub>D</sub> =30A	90	-	-	S
Gate Resistance	R <sub>g</sub>	V <sub>DS</sub> =V <sub>GS</sub> =0V, f =1MHz	-	5.7	-	Ω
<b>Dynamic characteristics</b>						
Input Capacitance	C <sub>iss</sub>	V <sub>DS</sub> =20V, V <sub>GS</sub> =0V, f =1MHz	-	5480	-	pF
Output Capacitance	C <sub>oss</sub>		-	1770	-	
Reverse Transfer Capacitance	C <sub>rss</sub>		-	22	-	
<b>Switching characteristics</b>						
Turn-on delay time	t <sub>d(on)</sub>	V <sub>DD</sub> =20V, I <sub>D</sub> =20A, V <sub>GS</sub> =10V, R <sub>G</sub> =10Ω	-	15	-	ns
Turn-on rise time	t <sub>r</sub>		-	38	-	
Turn-off delay time	t <sub>d(off)</sub>		-	183	-	
Turn-off fall time	t <sub>f</sub>		-	123	-	
Total Gate Charge	Q <sub>g</sub>	V <sub>DS</sub> =32V, I <sub>D</sub> =20A, V <sub>GS</sub> =10V	-	81.4	-	nC
Gate-Source Charge	Q <sub>gs</sub>		-	20.6	-	
Gate-Drain Charge	Q <sub>gd</sub>		-	6.2	-	
Reverse Recovery Charge	Q <sub>rr</sub>	I <sub>F</sub> =20A, di/dt=100A/us		4		nC
Reverse Recovery Time	T <sub>rr</sub>	I <sub>F</sub> =20A, di/dt=100A/us		17		ns
<b>Source-Drain Diode characteristics</b>						
Diode Forward voltage <sup>(3)</sup>	V <sub>DS</sub>	V <sub>GS</sub> =0V, I <sub>S</sub> =50A	-	-	1.2	V
Diode Forward current <sup>(4)</sup>	I <sub>S</sub>		-	-	200	A

**Notes:**

1. Repetitive Rating: pulse width limited by maximum junction temperature
2. EAS Condition: T<sub>J</sub>=25°C, V<sub>DD</sub>=20V, R<sub>G</sub>=25 Ω, L=0.5mH
3. Pulse Test: pulse width ≤300μs, duty cycle ≤2%
4. Surface Mounted on FR4 Board, t ≤10 sec

■ Test circuits and waveforms

Figure A: Gate Charge Test Circuit & Waveforms

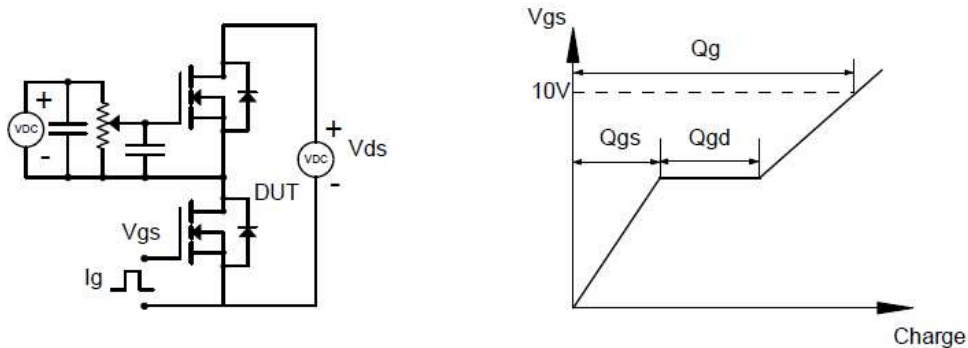

Figure B: Resistive Switching Test Circuit & Waveforms

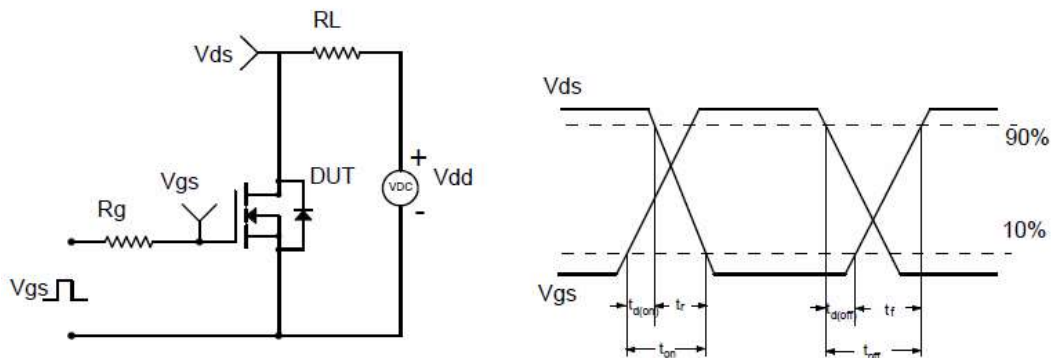

Figure C: Unclamped Inductive Switching (UIS) Test

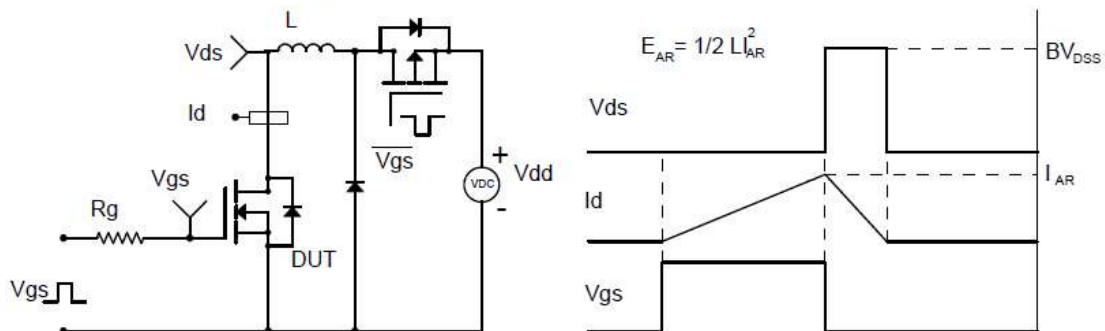
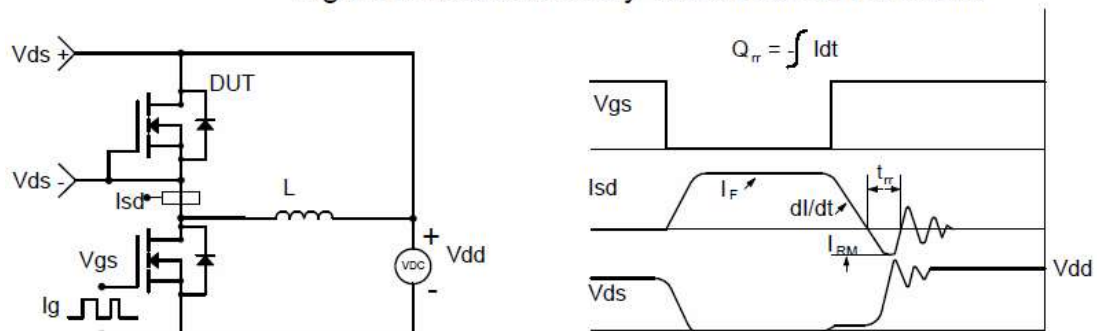

Figure D: Diode Recovery Test Circuit & Waveforms



**Electrical Characteristics Diagrams**

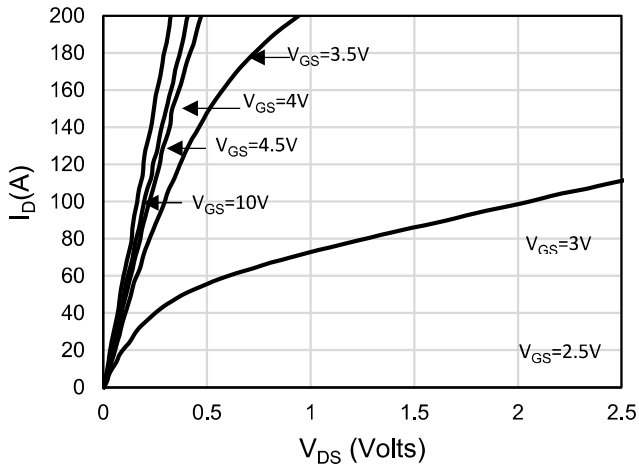

Figure 1: On-Region Characteristics

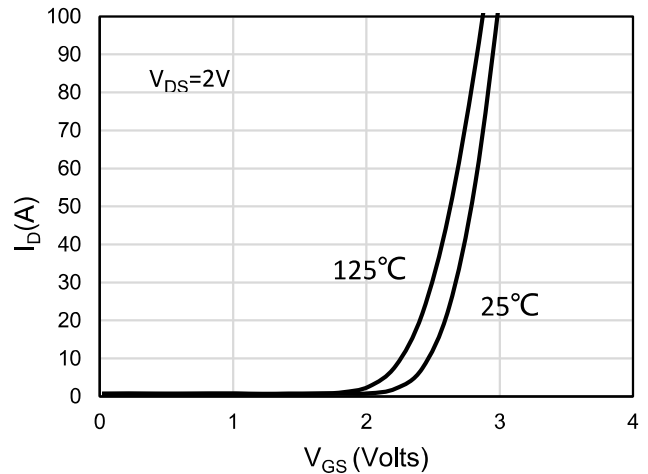

Figure 2: Transfer Characteristics

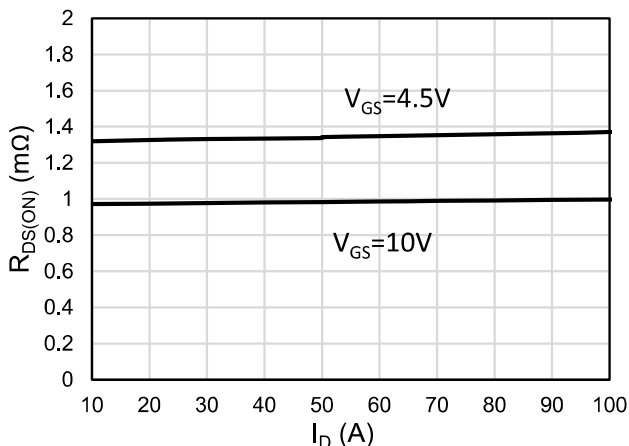

Figure 3: On-Resistance vs. Drain Current and Gate Voltage

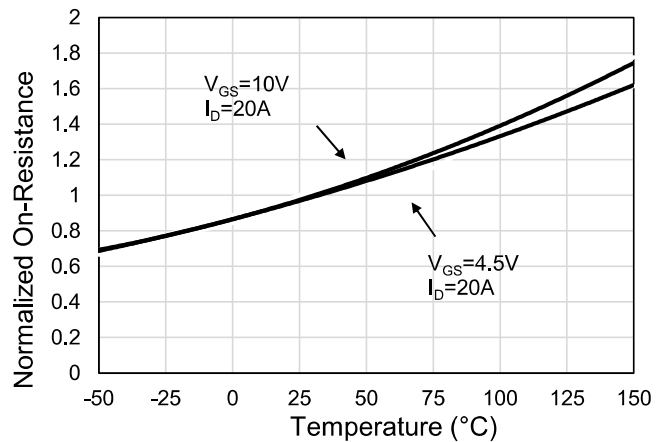

Figure 4: On-Resistance vs. Junction Temperature

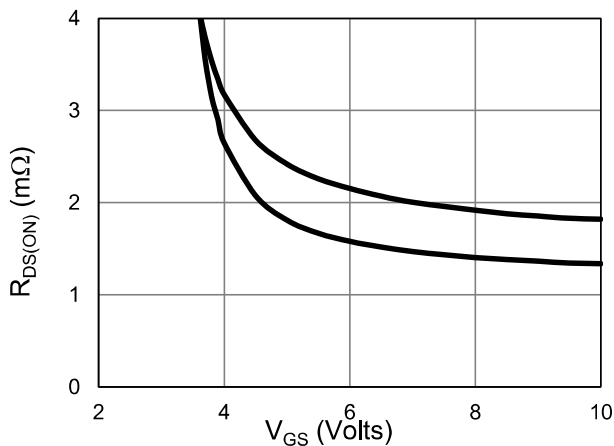

Figure 5: On-Resistance vs. Gate-Source Voltage

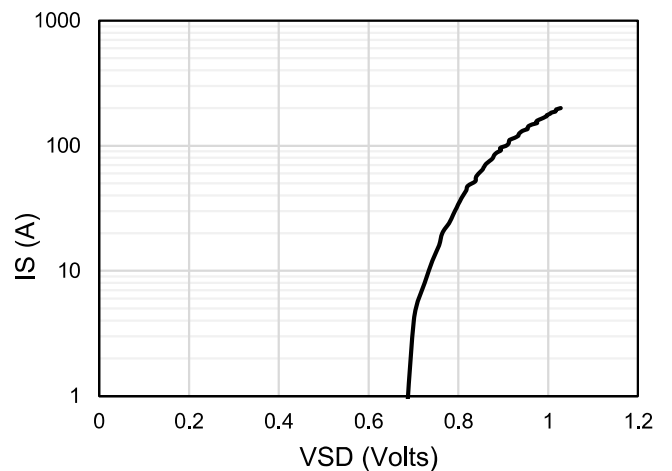

Figure 6: Body-Diode Characteristics

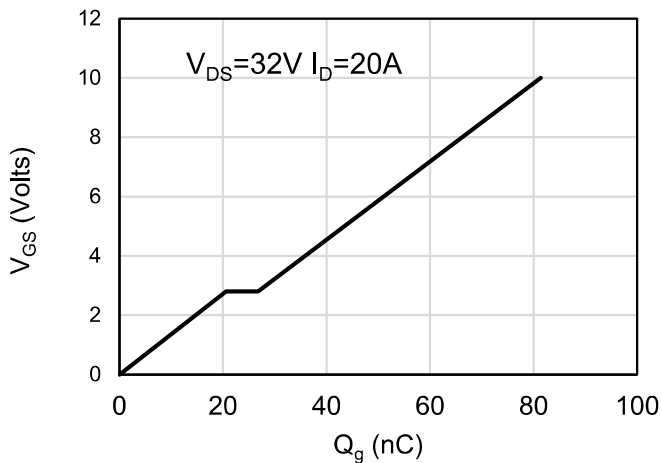

Figure 7: Gate-Charge Characteristics

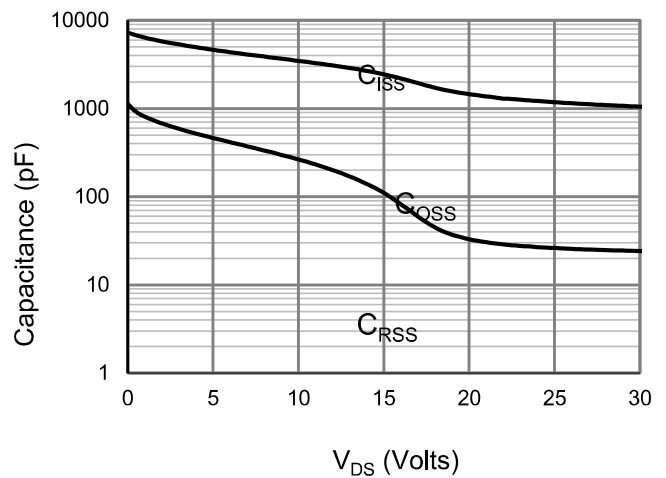

Figure 8: Capacitance Characteristics

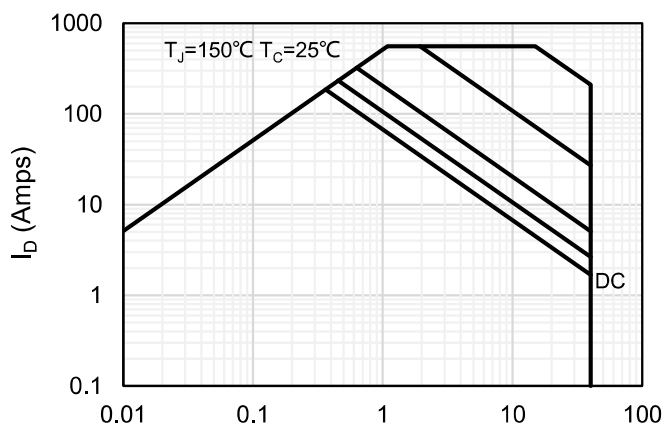

Figure 9: Maximum Forward Biased Safe Operating Area

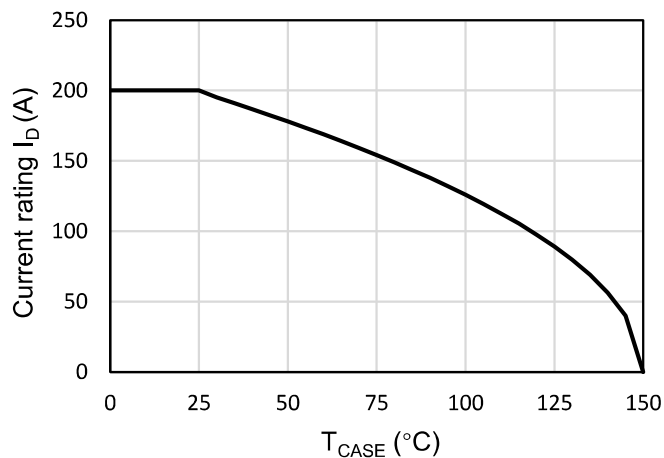
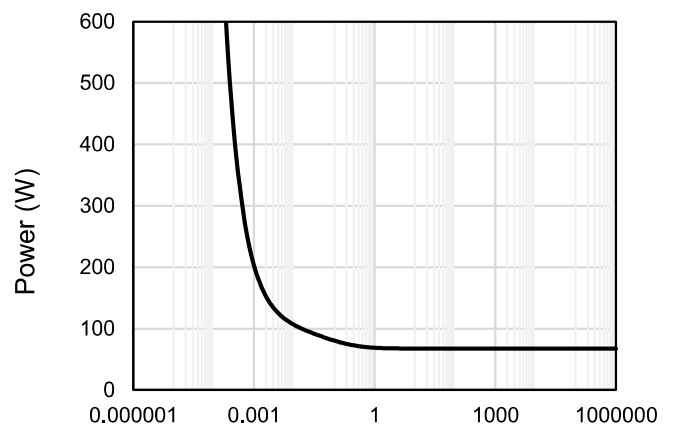

Figure 11: Current De-rating

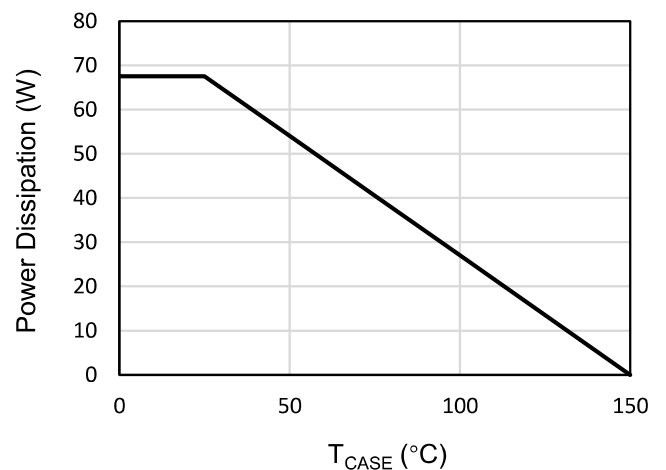

Figure 12: Power De-rating

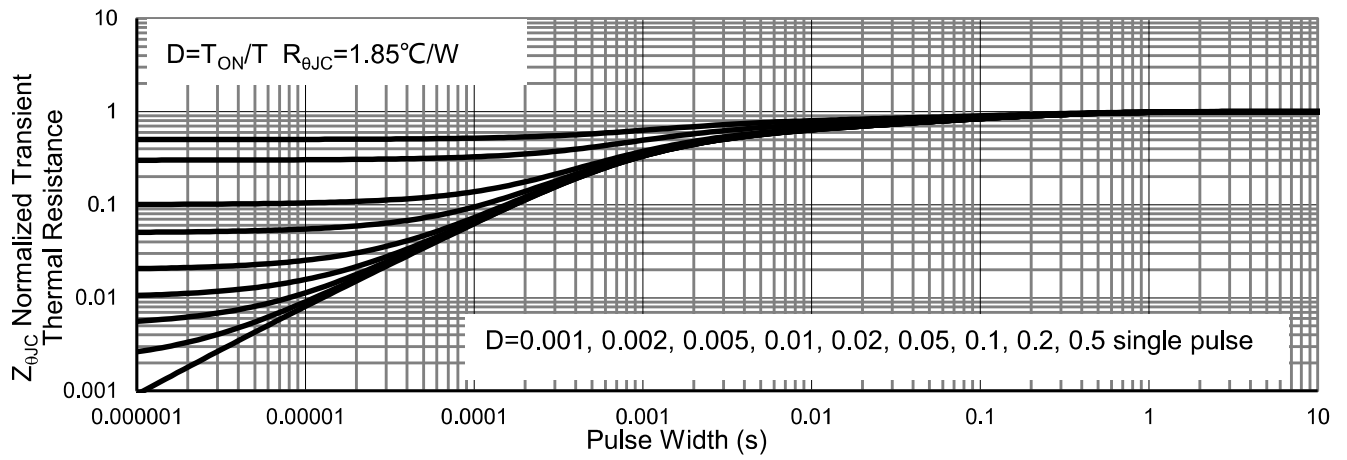
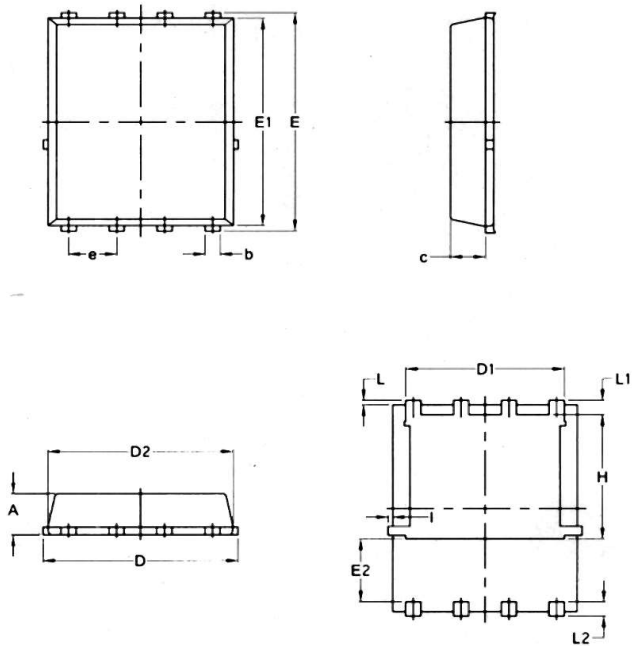

Figure 13: Normalized Maximum Transient Thermal Impedance

**PDFN5X6 Package Information**



PDFN5X6

SYMBOL	COMMON			
	MM		INCH	
	MIN.	MAX.	MIN.	MAX.
A	1.03	1.17	0.0406	0.0461
b	0.34	0.48	0.0134	0.0189
c	0.824	0.970	0.0324	0.0382
D	4.80	5.40	0.1890	0.2126
D1	4.11	4.31	0.1618	0.1697
D2	4.80	5.00	0.1890	0.1969
E	5.95	6.15	0.2343	0.2421
E1	5.65	5.85	0.2224	0.2303
E2	1.60	—	0.0630	—
e	1.27 BSC		0.05 BSC	
L	0.05	0.25	0.0020	0.0098
L1	0.38	0.50	0.0150	0.0197
L2	0.38	0.50	0.0150	0.0197
H	3.30	3.50	0.1299	0.1378
I	—	0.18	—	0.0070

## X-ON Electronics

Largest Supplier of Electrical and Electronic Components

*Click to view similar products for [MOSFET](#) category:*

*Click to view products by [Quan Li](#) manufacturer:*

Other Similar products are found below :

[IRFD120](#) [JANTX2N5237](#) [2SK2267\(Q\)](#) [BUK455-60A/B](#) [TK100A10N1,S4X\(S](#) [MIC4420CM-TR](#) [VN1206L](#) [NDP4060](#) [SI4482DY](#)  
[IRS2092STRPBF-EL](#) [IPS70R2K0CEAKMA1](#) [SQM120N06-3M5L-GE3](#) [TK31J60W5,S1VQ\(O](#) [TK31J60W,S1VQ\(O](#) [TK16J60W,S1VQ\(O](#)  
[2SK2614\(TE16L1,Q\)](#) [DMN1017UCP3-7](#) [EFC2J004NUZTDG](#) [P85W28HP2F-7071](#) [NTE2384](#) [DMC2700UDMQ-7](#) [DMN2080UCB4-7](#)  
[DMN61D9UWQ-13](#) [US6M2GTR](#) [DMN31D5UDJ-7](#) [DMP22D4UFO-7B](#) [IPS60R3K4CEAKMA1](#) [DMN1006UCA6-7](#) [DMN16M9UCA6-7](#)  
[STF5N65M6](#) [IRF40H233XTMA1](#) [STU5N65M6](#) [DMN6022SSD-13](#) [DMN13M9UCA6-7](#) [DMTH10H4M6SPS-13](#) [IPS60R360PFD7SAKMA1](#)  
[DMN2990UFB-7B](#) [SSM3K35CT,L3F](#) [IPLK60R1K0PFD7ATMA1](#) [2N7002W-G](#) [MCAC30N06Y-TP](#) [IPWS65R035CFD7AXKSA1](#)  
[MCQ7328-TP](#) [SSM3J143TU,LXHF](#) [PJMF280N65E1\\_T0\\_00201](#) [PJMF380N65E1\\_T0\\_00201](#) [PJMF280N60E1\\_T0\\_00201](#)  
[PJMF600N65E1\\_T0\\_00201](#) [PJMF900N65E1\\_T0\\_00201](#) [PJMF900N60E1\\_T0\\_00201](#)