

APG038N01G

N-Channel Enhancement Mosfet

AIIPOWER

DATA SHEET

Feature

- 100V,104A
 $R_{DS(ON)} < 3.8m\Omega @ V_{GS}=10V$ (TYP:3.1m Ω)
 $R_{DS(ON)} < 4.9m\Omega @ V_{GS}=4.5V$ (TYP:4.2m Ω)
- Split Gate Trench Technology
- Lead free product is acquired
- Excellent $R_{DS(ON)}$ and Low Gate Charge

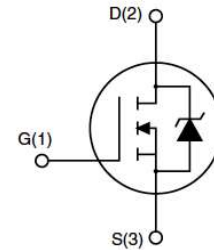

Application

- PWM applications
- Load Switch
- Power management

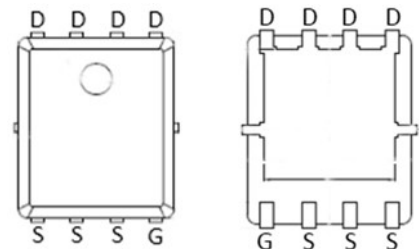

PDFN5X6

Package Marking and Ordering Information

Device Marking	Device	Device Package	Reel Size	Tape width	Quantity (PCS)
G038N01G	APG038N01G	PDFN5X6	-	-	5000

ABSOLUTE MAXIMUM RATINGS ($T_a=25^\circ\text{C}$ unless otherwise noted)

Parameter	Symbol	Value	Unit
Drain-Source Voltage	V_{DS}	100	V
Gate-Source Voltage	V_{GS}	± 20	V
Continuous Drain Current ($T_a=25^\circ\text{C}$)	I_D	104	A
Continuous Drain Current ($T_a=100^\circ\text{C}$)	I_D	65.7	A
Pulsed Drain Current ⁽¹⁾	I_{DM}	416	A
Single Pulsed Avalanche Energy ⁽²⁾	E_{AS}	324	mJ
Power Dissipation	P_D	67.5	W
Thermal Resistance from Junction to Case	$R_{\theta JC}$	1.85	$^\circ\text{C}/\text{W}$
Thermal Resistance from Junction to Ambient	$R_{\theta JA}$	51.4	$^\circ\text{C}/\text{W}$
Junction Temperature	T_J	150	$^\circ\text{C}$
Storage Temperature	T_{STG}	-55~ +150	$^\circ\text{C}$

MOSFET ELECTRICAL CHARACTERISTICS(T_a=25°C unless otherwise noted)

Parameter	Symbol	Test Condition	Min	Type	Max	Unit
Static Characteristics						
Drain-source breakdown voltage	V _{(BR)DSS}	V _{GS} = 0V, I _D =250μA	100	-	-	V
Zero gate voltage drain current	I _{DSS}	V _{DS} =100V, V _{GS} = 0V	-	-	1	μA
Gate-body leakage current	I _{GSS}	V _{GS} = ±20V, V _{DS} = 0V	-	-	±100	nA
Gate threshold voltage ⁽³⁾	V _{GS(th)}	V _{DS} =V _{GS} , I _D =250μA	1.5	2.0	3.0	V
Drain-source on-resistance ⁽³⁾	R _{DS(on)}	V _{GS} =10V, I _D =30A	-	3.1	3.8	mΩ
		V _{GS} =4.5V, I _D =20A	-	4.2	4.9	mΩ
Gate Resistance	R _g	V _{DS} =V _{GS} =0V, f =1MHz	-	1.7	-	Ω
Dynamic characteristics						
Input Capacitance	C _{iss}	V _{DS} =50V, V _{GS} =0V, f =1MHz	-	5980	-	pF
Output Capacitance	C _{oss}		-	1270	-	
Reverse Transfer Capacitance	C _{rss}		-	31.5	-	
Switching characteristics						
Turn-on delay time	t _{d(on)}	V _{DD} =50V, I _D =20A, V _{GS} =10V, R _G =3Ω	-	23.5	-	ns
Turn-on rise time	t _r		-	33.6	-	
Turn-off delay time	t _{d(off)}		-	89	-	
Turn-off fall time	t _f		-	25.7	-	
Total Gate Charge	Q _g	V _{DS} =50V, I _D =20A, V _{GS} =10V	-	100	-	nC
Gate-Source Charge	Q _{gs}		-	17	-	
Gate-Drain Charge	Q _{gd}		-	20.7	-	
Reverse Recovery Chrage	Q _{rr}	I _F =80A, di/dt=100A/us		103.8		nC
Reverse Recovery Time	T _{rr}	I _F =80A, di/dt=100A/us		62.6		ns
Source-Drain Diode characteristics						
Diode Forward voltage ⁽³⁾	V _{DS}	V _{GS} =0V, I _S =40A	-	0.85	1.3	V
Diode Forward current ⁽⁴⁾	I _S		-	-	104	A

Notes:

1. Repetitive Rating: pulse width limited by maximum junction temperature
2. EAS Condition: T_J=25°C, V_{DD}=50V, R_G=25 Ω, L=0.5Mh, I_{AS}=36A
3. Pulse Test: pulse width≤300μs, duty cycle≤2%
4. Surface Mounted on FR4 Board, t≤10 sec

■ Test circuits and waveforms

Figure A: Gate Charge Test Circuit & Waveforms

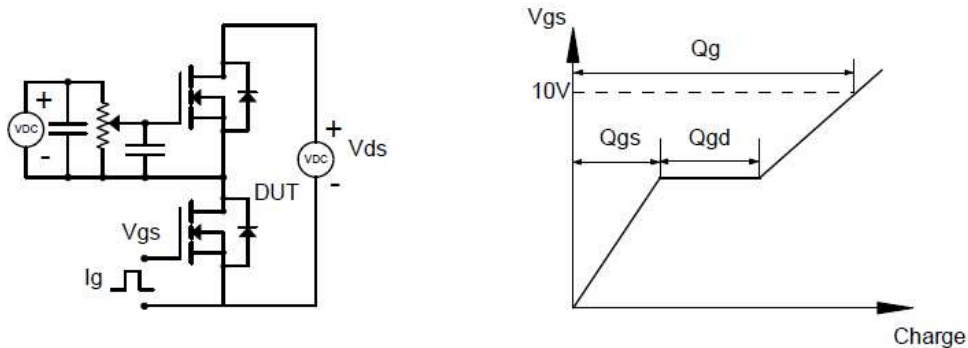

Figure B: Resistive Switching Test Circuit & Waveforms

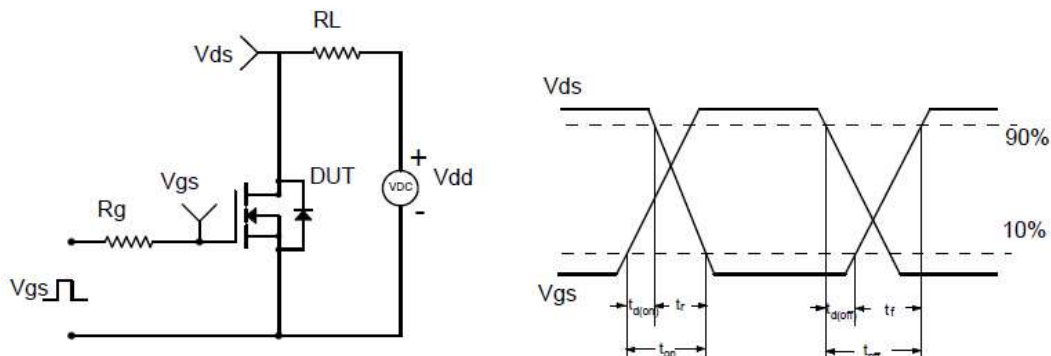

Figure C: Unclamped Inductive Switching (UIS) Test

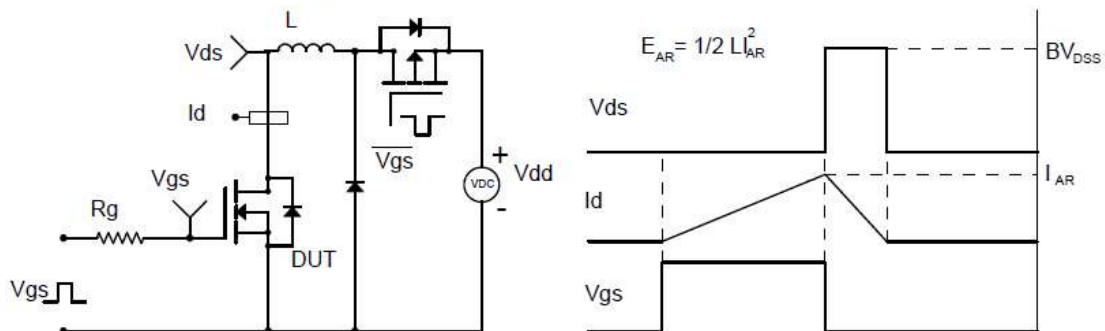
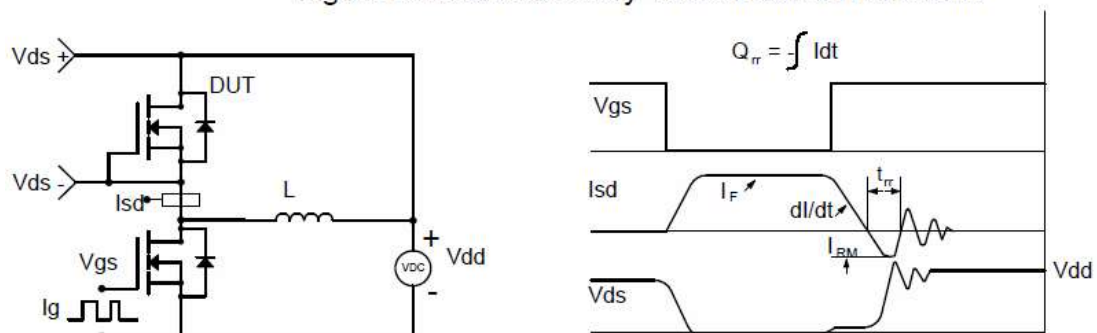

Figure D: Diode Recovery Test Circuit & Waveforms



Typical Electronic and Thermal Characteristics

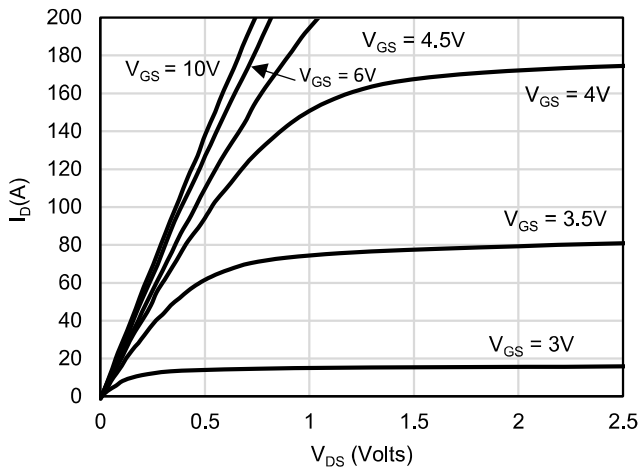

Figure 1: On-Region Characteristics

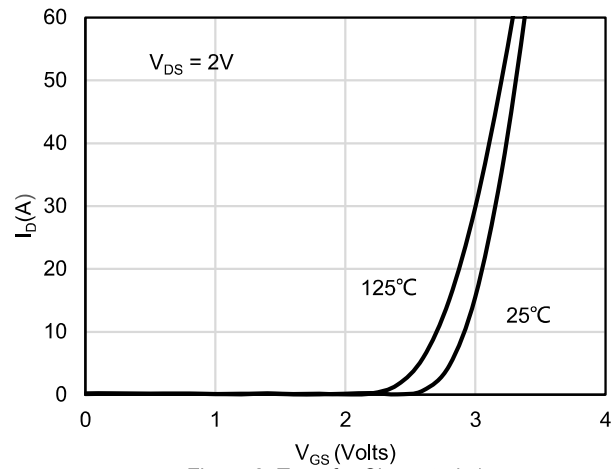

Figure 2: Transfer Characteristics

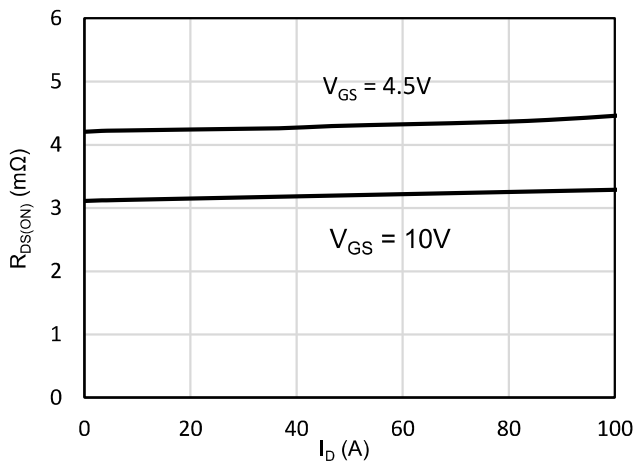

Figure 3: On-Resistance vs. Drain Current and Gate Voltage

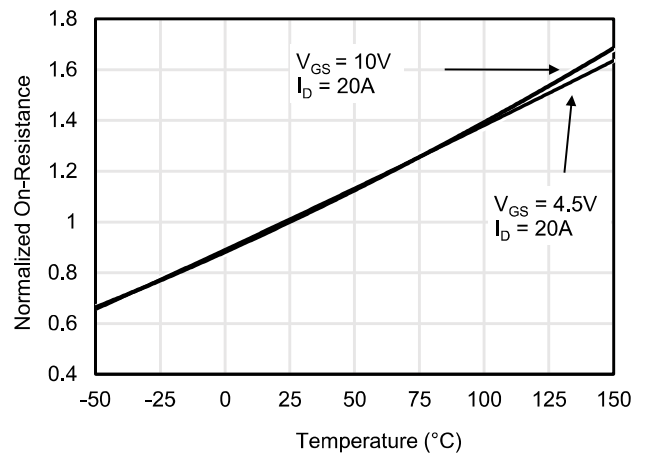

Figure 4: On-Resistance vs. Junction Temperature

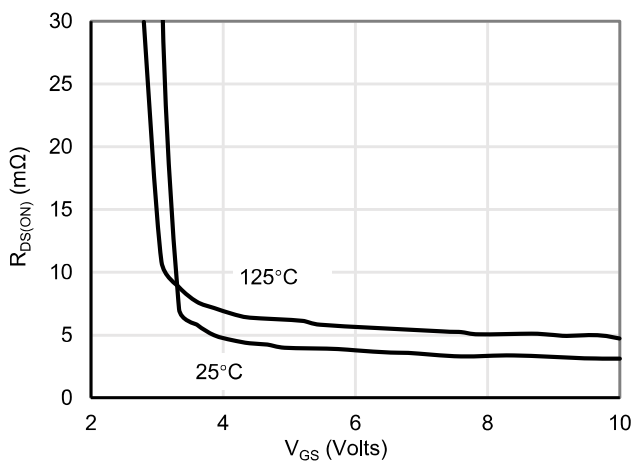

Figure 5: On-Resistance vs. Gate-Source Voltage

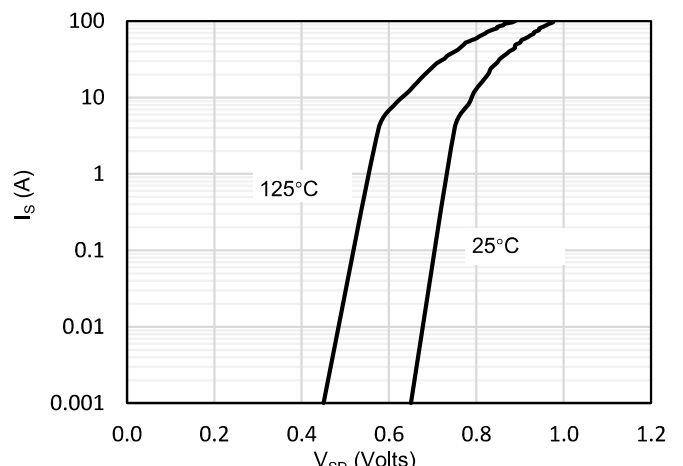
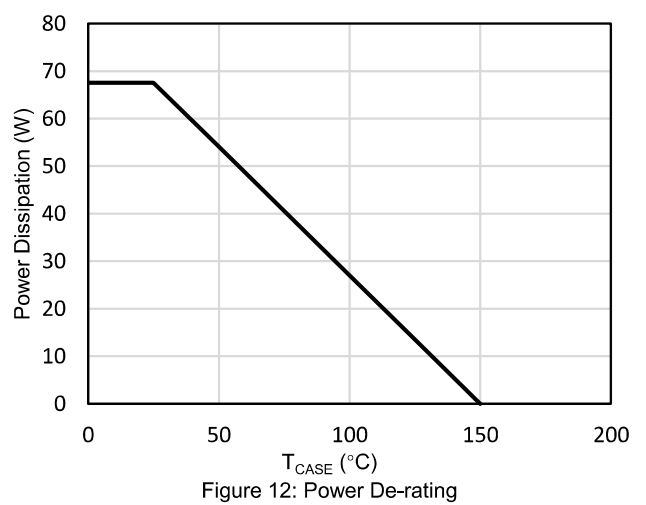
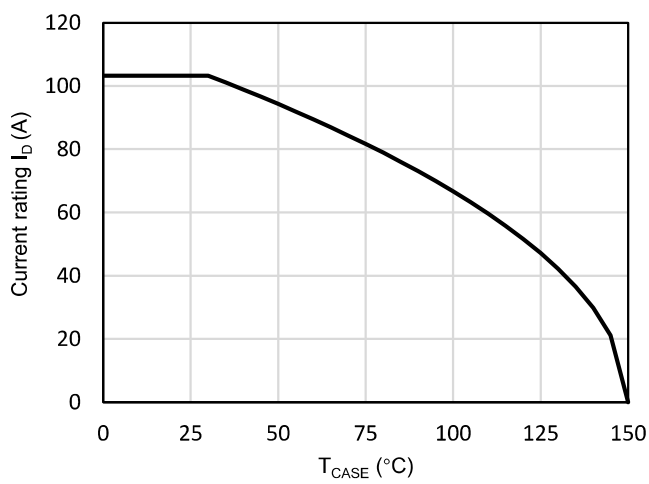
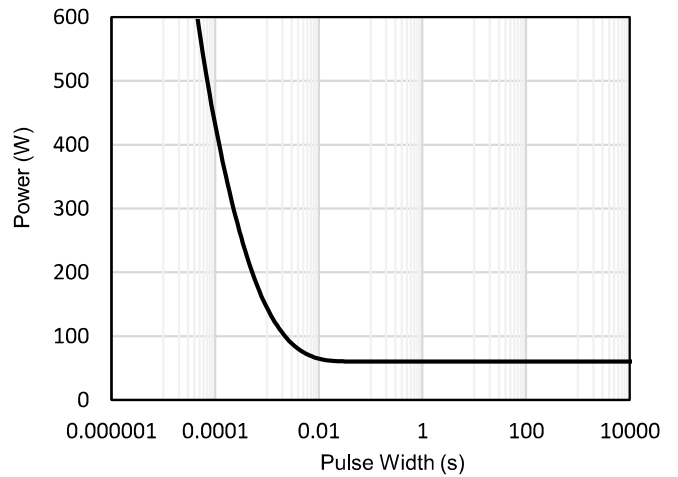
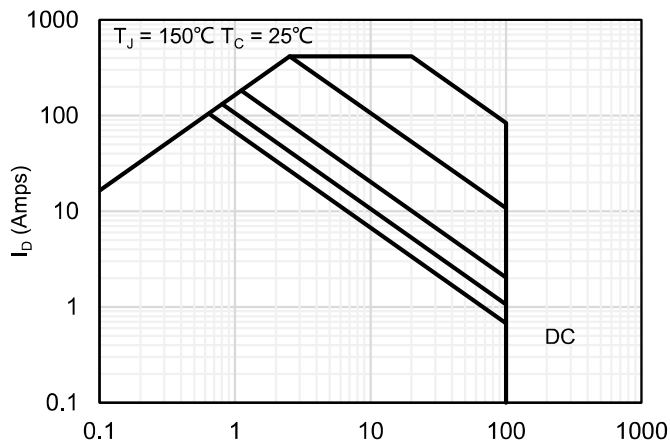
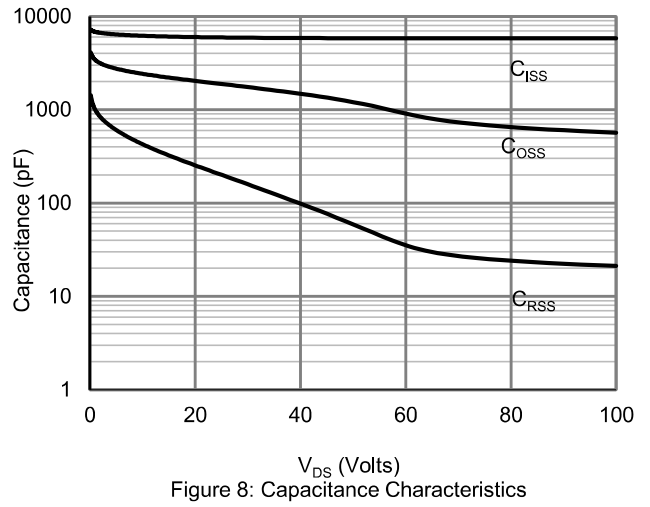
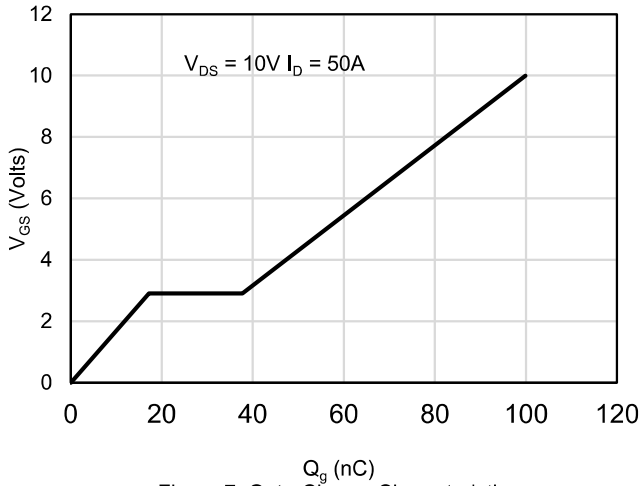
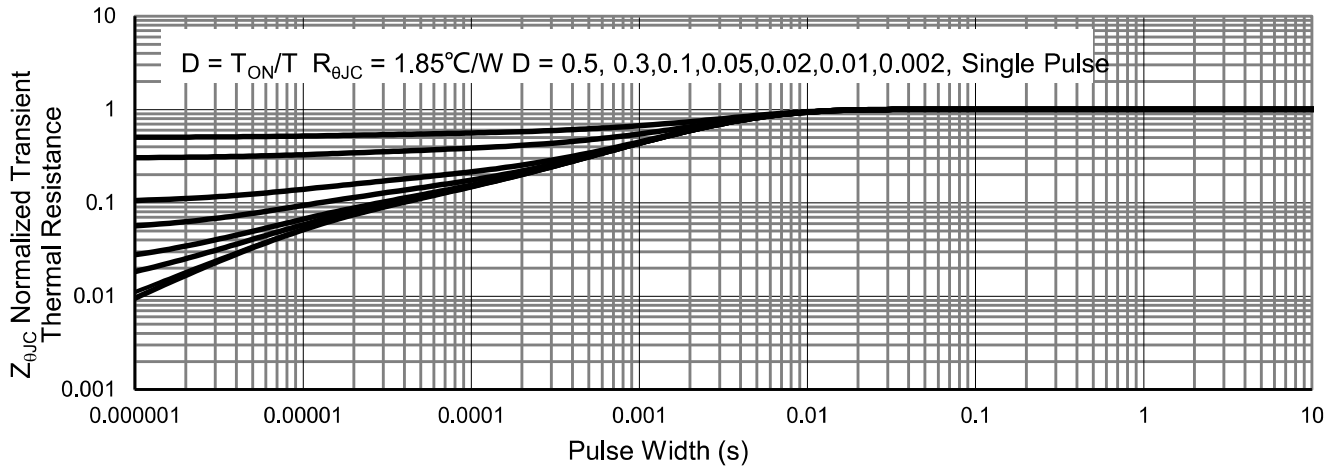
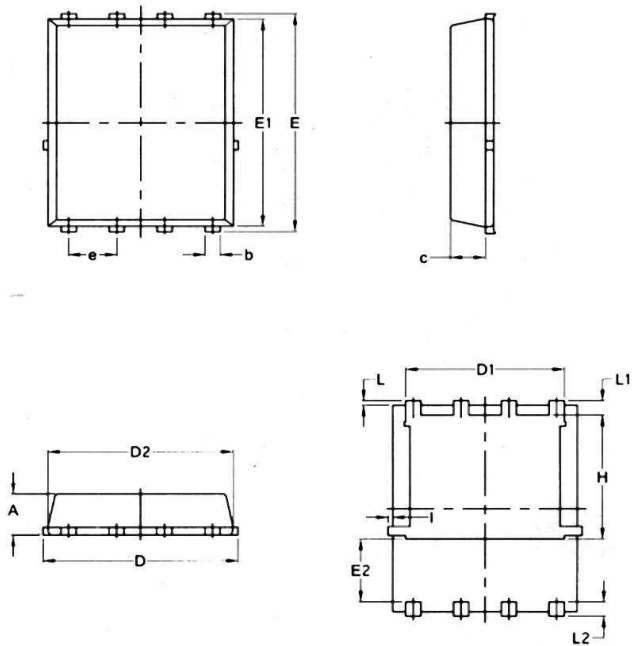

Figure 6: Body-Diode Characteristics





PDFN5X6 Package Information



PDFN5X6

SYMBOL	COMMON			
	MM		INCH	
	MIN.	MAX.	MIN.	MAX.
A	1.03	1.17	0.0406	0.0461
b	0.34	0.48	0.0134	0.0189
c	0.824	0.970	0.0324	0.0382
D	4.80	5.40	0.1890	0.2126
D1	4.11	4.31	0.1618	0.1697
D2	4.80	5.00	0.1890	0.1969
E	5.95	6.15	0.2343	0.2421
E1	5.65	5.85	0.2224	0.2303
E2	1.60	—	0.0630	—
e	1.27 BSC		0.05 BSC	
L	0.05	0.25	0.0020	0.0098
L1	0.38	0.50	0.0150	0.0197
L2	0.38	0.50	0.0150	0.0197
H	3.30	3.50	0.1299	0.1378
I	—	0.18	—	0.0070

X-ON Electronics

Largest Supplier of Electrical and Electronic Components

Click to view similar products for [MOSFET](#) category:

Click to view products by [Quan Li](#) manufacturer:

Other Similar products are found below :

[IRFD120](#) [JANTX2N5237](#) [2SK2267\(Q\)](#) [BUK455-60A/B](#) [TK100A10N1,S4X\(S](#) [MIC4420CM-TR](#) [VN1206L](#) [NDP4060](#) [SI4482DY](#)
[IRS2092STRPBF-EL](#) [IPS70R2K0CEAKMA1](#) [SQM120N06-3M5L-GE3](#) [TK31J60W5,S1VQ\(O](#) [TK31J60W,S1VQ\(O](#) [TK16J60W,S1VQ\(O](#)
[2SK2614\(TE16L1,Q\)](#) [DMN1017UCP3-7](#) [EFC2J004NUZTDG](#) [P85W28HP2F-7071](#) [NTE2384](#) [DMC2700UDMQ-7](#) [DMN2080UCB4-7](#)
[DMN61D9UWQ-13](#) [US6M2GTR](#) [DMN31D5UDJ-7](#) [DMP22D4UFO-7B](#) [IPS60R3K4CEAKMA1](#) [DMN1006UCA6-7](#) [DMN16M9UCA6-7](#)
[STF5N65M6](#) [IRF40H233XTMA1](#) [STU5N65M6](#) [DMN6022SSD-13](#) [DMN13M9UCA6-7](#) [DMTH10H4M6SPS-13](#) [IPS60R360PFD7SAKMA1](#)
[DMN2990UFB-7B](#) [SSM3K35CT,L3F](#) [IPLK60R1K0PFD7ATMA1](#) [2N7002W-G](#) [MCAC30N06Y-TP](#) [IPWS65R035CFD7AXKSA1](#)
[MCQ7328-TP](#) [SSM3J143TU,LXHF](#) [PJMF280N65E1_T0_00201](#) [PJMF380N65E1_T0_00201](#) [PJMF280N60E1_T0_00201](#)
[PJMF600N65E1_T0_00201](#) [PJMF900N65E1_T0_00201](#) [PJMF900N60E1_T0_00201](#)