

SERVICE SWITCH

# PSR





# Thank you for purchasing PSR service switch.

Please read this manual and follow its guidelines.

## Table of contents

Intended use and method of operation	4
Device properties, technical parameters	5
Connection diagram	6
Reading work status via LED signals	7
Sound signaling	10
Sensing elements	11
Service switch dimensions	12
Front panel description	13



## 1. INTENDED USE AND METHOD OF OPERATION

PSR service switch serves as an emergency street lighting control. In the event of the clock failure, it may take over its tasks, thus allowing service engineers to identify, diagnose and remove the defect. The system may be mounted in any control cabinet. Its major advantage is a possibility of connecting two sensors at a time, which increases failure-free operation of the device. If one sensor is defective or in the event of an act of vandalism resulting in the damage to the sensor (e.g. removed or covered as a result of painting), the second sensor takes over all functions and controls the device independently.

The device detects if measuring elements have been connected and if they work properly. In case of any irregularities or lack of connection of light-sensitive elements, a relevant LED light in the front panel will activate. If light-sensitive elements have not been connected, ST control output in FOTO mode is inactive. The device has regular boundary values of lighting activation (15 lx) and deactivation (25 lx). Two information outputs Q1 and Q2 inform about switch knob location and defective operation of sensors or their absence.

## 2. DEVICE PROPERTIES, TECHNICAL PARAMETERS

### 2.1 Device properties

- emergency lighting control
- analogue light intensity measurement
- optical and sound signaling of work status
- possible to connect two sensors at a time
- possible to mount in any control cabinet

### 2.2 Technical parameters

- supply voltage: 230 VAC +10/-15%, 50Hz
- dimensions (W/H/D): 68 x 90 x 65 mm
- device width: 4 modules
- number of control outputs: 1
- number of information outputs: 2
- measurement range 1- 500 lx
- output current-carrying capacity: 3 A/230V
- ambient temperature: -40°C to +85°C
- protection class: PSR - IP20, sensor - IP67

### 3. CONNECTION DIAGRAM

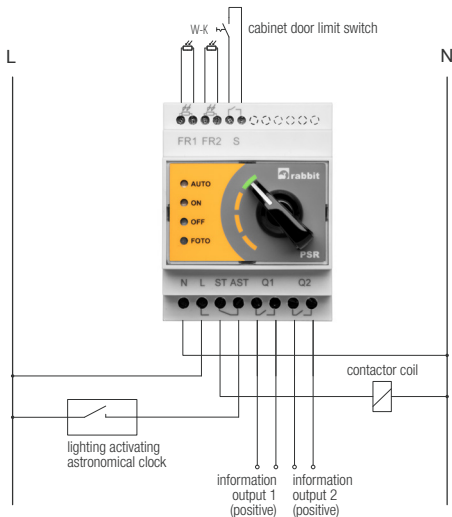

PSR service switch connection diagram

## 4. READING WORK STATUS VIA LED SIGNALS

PSR service switch adopts LED lights to inform the user about current working mode, sensor efficiency and presence of sensors.

### LED light colors:

1. AUTO plain green
2. ON plain green
3. OFF plain green
4. FOTO two-colored green/red

Activity of modes and any failures are signaled by means of the following: Green LED lights (items 1, 2, 3 and 4) and red LED light located in the item 4, which has been presented in greater detail below:

LED LIGHT WORK MODE	AUTO	ON	OFF	FOTO
AUTO	constant green	x	x	flashing red * or constant red **
ON	x	flashing green	x	flashing red * or constant red **
OFF	x	x	flashing green	flashing red * or constant red **
FOTO	x	x	x	flashing green, flashing red * or constant red **

Table 1. Switch status signaling through front panel lights.

\* If one light-sensitive element is missing in the system, LED light in FOTO mode flashes every 1 second, if no light-sensitive element is connected to the switch, the light flashes twice within a second.

\*\* If a microcontroller checks the presence of sensors in the system, that is in other words their physical connection, but fails to measure the change of luminous flux on the surface of sensors within a day, it will notify the user of this by activating the red LED light in FOTO mode, which will glow constantly.



## DESCRIPTION OF DEVICE WORK MODES:

- 1. AUTO:** A default basic work mode, efficient system composed of properly working clock, contactor and switch, is AUTO mode – which means that the clock is the most important element and it is the clock that determines when to activate the main contactor along with the group of luminaires. In this position green LED light glows constantly. In addition, in AUTO mode LED light in FOTO mode may glow as well, which may suggest a failure of sensors or lack of connection to the unit.
- 2. ON:** In ON mode – PSR is the main element. It serves to supply phase (L) to the main contactor. What is more, in ON mode a LED light in FOTO mode may also glow, which may suggest a failure of sensors or lack of connection to the unit.
- 3. OFF:** In OFF mode – in main contactor coil there is no potential, which suggests that it is deactivated. Additionally, in ON mode a LED light in FOTO mode may glow, which may suggest a failure of sensors or lack of connection to the unit.
- 4. FOTO:** In FOTO mode – PSR is the main element, and to be more specific – sensor circuit with a microcontroller. Depending on the lighting intensity, the main contactor is activated at a proper time. The system may base its operation solely on one sensor, but it is not advisable. In FOTO mode a time-lag has been applied in order to prevent against accidental additional illumination (a car going by) or covering the surface of sensors. Such a time-lag lasts 60 seconds.

## 5. SOUND SIGNALING

The device is equipped with a buzzer, that is an element which generates an acoustic wave. It cooperates with the limit switch located in the cabinet. The sound signaling is active in ON, OFF and FOTO modes and informs that the user has left the device in a different position than default AUTO and closed cabinet door. Once PSR has been closed, it makes a sound for 60 seconds and then falls quiet automatically. If the cabinet door is opened again before the period of 60 seconds has passed, the device stops making a sound. The limit switch must be connected to the S input. Polarization in this connection does not matter.



A 60-second sound informs the user that the switch is active and the cabinet door has been closed.



## 6. SENSING ELEMENTS

Sensing elements, also referred to as light-sensitive resistors, are located in the waterproof casing. These elements do not have polarization so there are no limits in terms of their connection. It is necessary to make sure the light-sensitive resistors are connected to relevant inputs (FR1 and FR2). It is advisable to use sensors recommended by Rabbit because they have specific parameters, i.e. dark resistance, defined resistance for 50lx intensity. What is more, the sensor casing is equipped with a resistor, connected parallel to the light-sensitive resistor, with a specific value whose aim is to assure a stable operation of the unit. Lack of this resistor may lead to faulty operation of the unit.



## 7. PSR SERVICE SWITCH DIMENSIONS

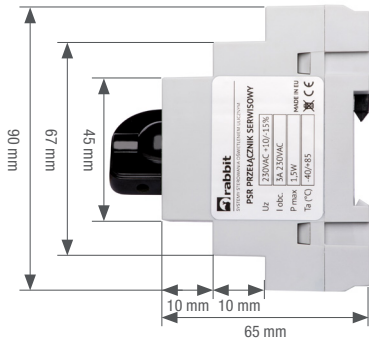

## 8. FRONT PLATE DESCRIPTION



Symbol	Description	WY/WE
FR1	Joint of sensor no. 1	WE
FR2	Joint of sensor no. 2	WE
S	Limit switch joint	WE
N	Neutral cable joint	WE
L	Live cable joint	WE
ST	Main contactor phase	WY
AST	External clock phase (ASTRO)	WE
Q1	Information on switch position (active, when other than AUTO)	WY
Q2	Information on sensor failure	WY



---

# WARRANTY CARD

---

## WARRANTY CONDITIONS

1. The manufacturer assures the highest quality of products included in this Warranty Card.
2. The warranty period is 2 years from the sale date.
3. The warranty condition is to deliver the claimed product with intact seal to the service company with the warranty card and purchase proof.
4. Defects or damages occurring during the warranty period will be removed free of charge during 14 days from delivering the device to the service company.
5. The warranty period is prolonged with time during which the device is unsuitable for use. When user receives new product instead of the defective one, the warranty period starts from the beginning. When the product part is replaced, the above principle is valid for that part.
6. The warranty does not include damages resulting from:
  - incorrect connection,
  - short-circuits in controlled circuits,
  - lightning,
  - mechanical damages and resulting defects,
  - using the device in contrary to the operation manual.
7. To all matters not settled herein provisions of the Civil Code shall apply.

---

# WARRANTY CARD

---

DEVICE NAME AND TYPE

PSR

SALE DATE

.....

IDENTIFICATION NO.

.....

.....  
AUTHORIZED PERSON STAMP AND SIGNATURE



## SERVICE COMPANY ADDRESS

Rabbit Sp. z o.o.  
ul. Krakowska 141-155  
50-428 Wrocław, POLAND  
tel./fax: +48 71 328 50 65  
e-mail: [rabbit@rabbit.pl](mailto:rabbit@rabbit.pl)  
[www.rabbit.pl](http://www.rabbit.pl)



# **X-ON Electronics**

Largest Supplier of Electrical and Electronic Components

*Click to view similar products for [Mounting Fixings](#) category:*

*Click to view products by [RABBIT](#) manufacturer:*

Other Similar products are found below :

[5912235-1 REV](#) - [5912235-2](#) [007310](#) [007541](#)

6-141-P 620HA038NF09 620HA038NF11  
M81714/60-22-01 L/C MA1EAF1200 70-  
584649-01P 71-074914-006 71-215091-8S  
712HA170B23128-N 71-441549-19S 71-  
441864-5S EX-13-3-B-16-325PN 75-69116-  
8S 75-69211-3P 75-69214-6P 75-69224-5S  
770-006A109R 770-006A208W1 770-  
006A703W1 770-006A704W1 770-  
006A706W1 770-007A203W1 770-

007A204W1 770-007A207W1 770-  
007A704W1 770-007A707W1 770-  
010Y707W1 770-011T201 770-011T203  
770-011T701W1 770-011T702W1 770-  
013311 770-013312 770-013711W1 770-  
018S102R 770-018S103R 770-018S105R  
770-018S202W1 770-018S204W1 770-  
018S205W1 770-018S302W1 770-  
018S305W1 770-018S700W1 770-

018S701W1 770-018S702W1 770-  
020S705W1