

VHF ANTENNA, FLEXIBLE WHIP

136 MHz – 174 MHz

MD10-003

Series : Antenna

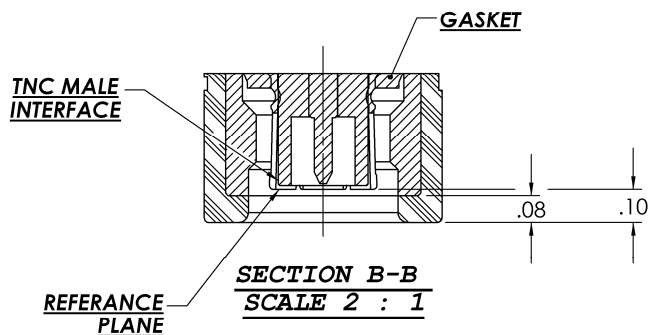
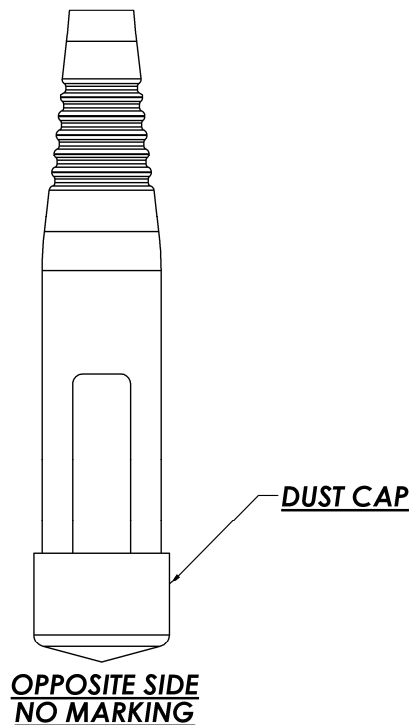
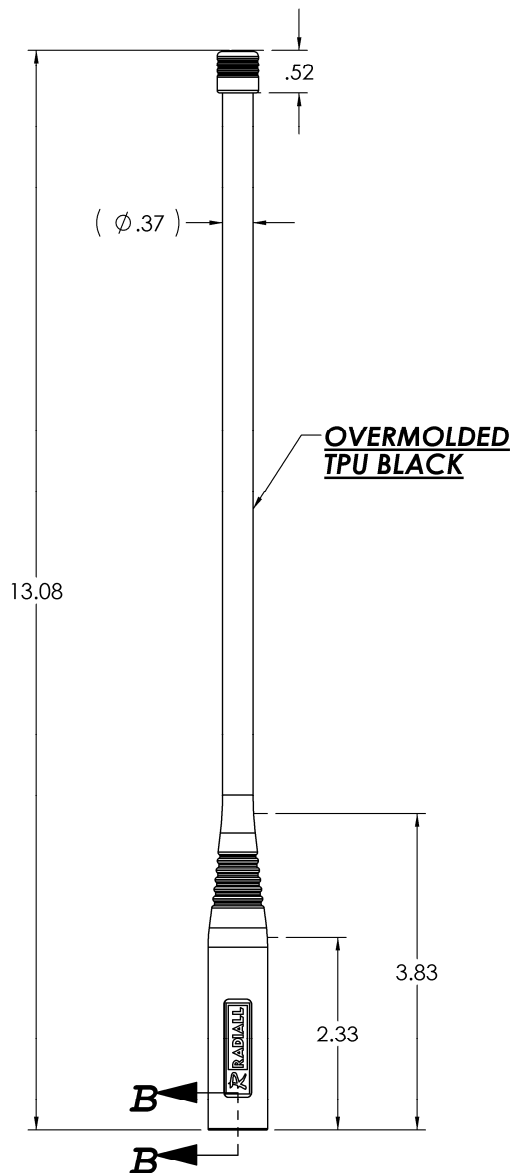

UNITS: INCH	
-------------	--

All dimensions are inches

Issue : 1041

In the effort to improve our products, we reserve the right to make changes judged to be necessary.



VHF ANTENNA, FLEXIBLE WHIP

136 MHz – 174 MHz

MD10-003

Series : **Antenna**

ELECTRICAL CHARACTERISTICS

Frequency :	136 - 174 MHz
Nominal Impedance:	50 Ω
VSWR*:	3.0:1 Max
Peak Gain:	>-2 dBi
Radiation Pattern	
Horizontal Plane (Θ=90°):	Omni-directional
Vertical Plane (Φ=0°/90):	Dipolar
Polarization :	Linear Vertical
Power withstanding :	8 W (CW)
Connector type :	TNC Male

MECHANICAL CHARACTERISTICS

Antenna Color :	Black matte
Antenna Material :	Texin 245
Antenna Texture :	Flat
Flexibility:	180° - 500 cycles
Matching Unit Length:	2.70 Inches
Weight (antenna):	3 Oz
Overall length :	13.23 Inches

*: Measured when antenna is mounted on a handheld radio chassis held by hand

Issue : 1041

In the effort to improve our products, we reserve the right to make changes judged to be necessary.



VHF ANTENNA, FLEXIBLE WHIP

MD10-003

136 MHz – 174 MHz

Series : **Antenna**

ENVIRONMENTAL CHARACTERISTICS

Product Compliant with the RoHS (Restriction of Hazardous Substances) and WEEE (Waste Electrical and Electronics Equipment) requirements

Operating Temperature :.....	-33 / +60 °C MIL-STD-810F, Methods 501.4 & 502.4, Procedure II
Storage Temperature :.....	-51 / +71 °C MIL-STD-810F, Methods 501.4 & 502.4, Procedure I
Sand & Dust:	Ambient +70 °C Concentration 2.2 & 10.6 g/m³ Velocity 3450-5700 & 300-1750 ft/min MIL-STD-810F, Methods 510.4, Procedure I & Procedure II
Salt Fog:.....	5% Salt Concentration 96 Hours MIL-STD-810F, Methods 509.4
Humidity:	95% Relative Humidity +30/+60 °C MIL-STD-810F, Methods 507.4
Fungus:	US Standard Set Of Test Fungi Duration 28 Days MIL-STD-810F, Method 508.5
Shock (Transit Drop):.....	Drop Height 19.7 Inches MIL-STD-810F, Method 516.5, Procedure IV, 26 Drops
Vibration : (Loose Cargo Transportation)	MIL STD 810F Stand alone & attached to the radio at ambient temperature Method 514.5 Procedure II Category 5
Immersion :.....	MIL-STD-810F 2 Meters, Method 512.4 Salt Water Complete Immersion 2 Hours Conditioning Temperature: 27 ° Celsius above water temperature
Flexibility :	180 degree bend, 500x, .5 Hz Max

OTHER CHARACTERISTICS

Issue : 1041

In the effort to improve our products, we reserve the right to make changes judged to be necessary.



VHF ANTENNA, FLEXIBLE WHIP

MD10-003

136 MHz – 174 MHz

Series : Antenna

CURVES

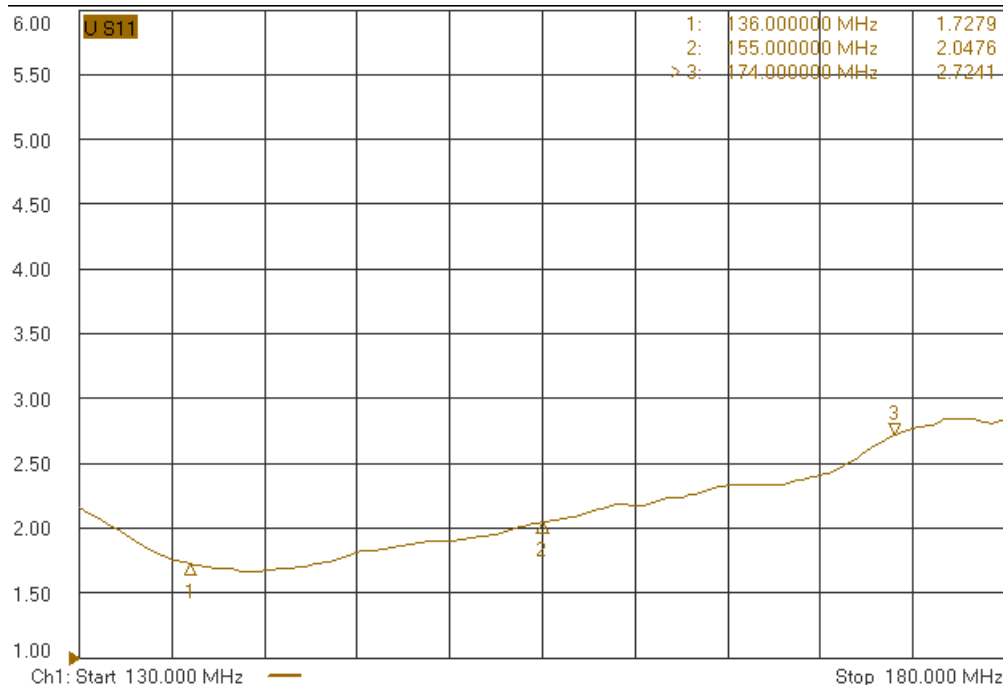

Figure 1: VSWR measured holding the radio chassis.

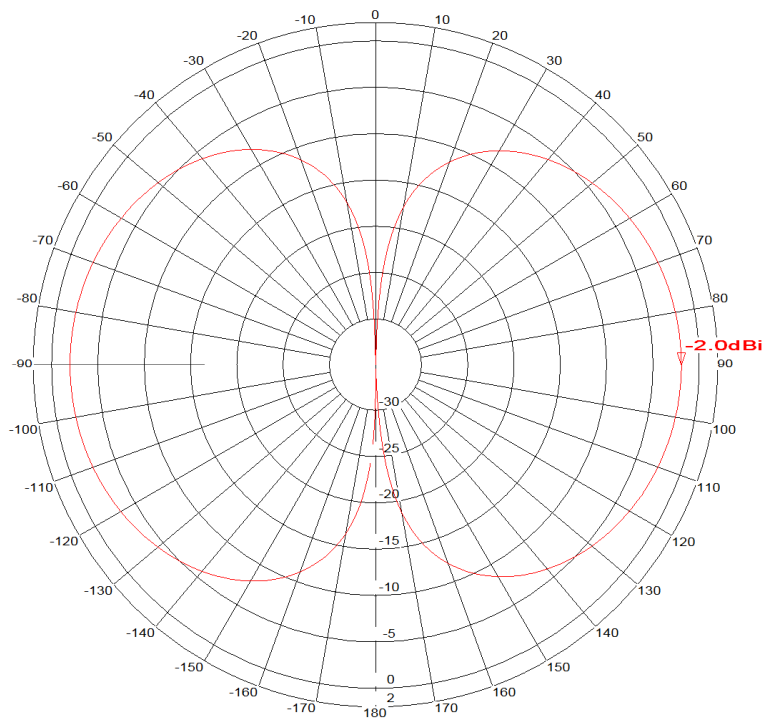

Figure 2: Elevation Gain Patterns @ 136 MHz

Issue : 1041

In the effort to improve our products, we reserve the right to make changes judged to be necessary.



VHF ANTENNA, FLEXIBLE WHIP

MD10-003

136 MHz – 174 MHz

Series : Antenna

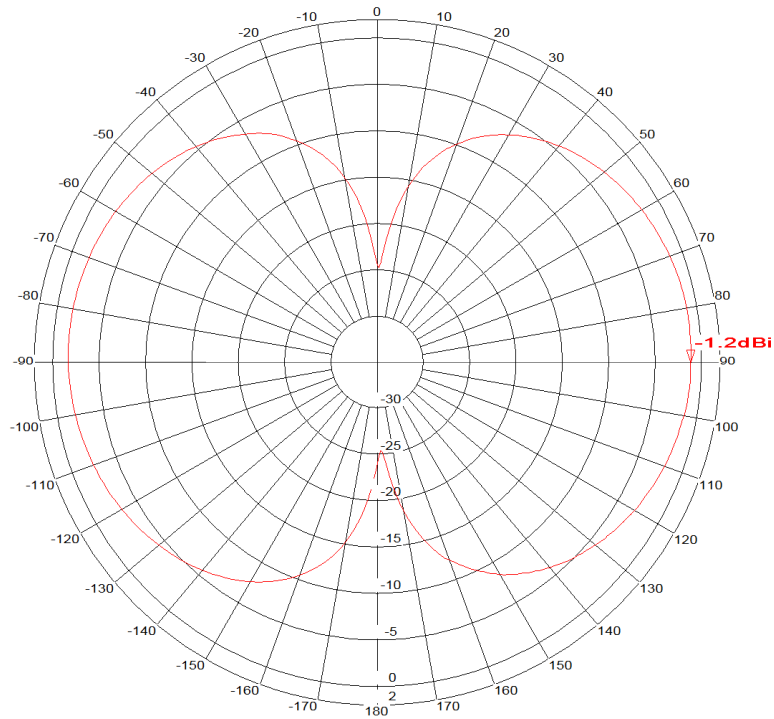

Frequency: 0.155 GHz

Figure 3: Elevation Gain Patterns @ 155 MHz

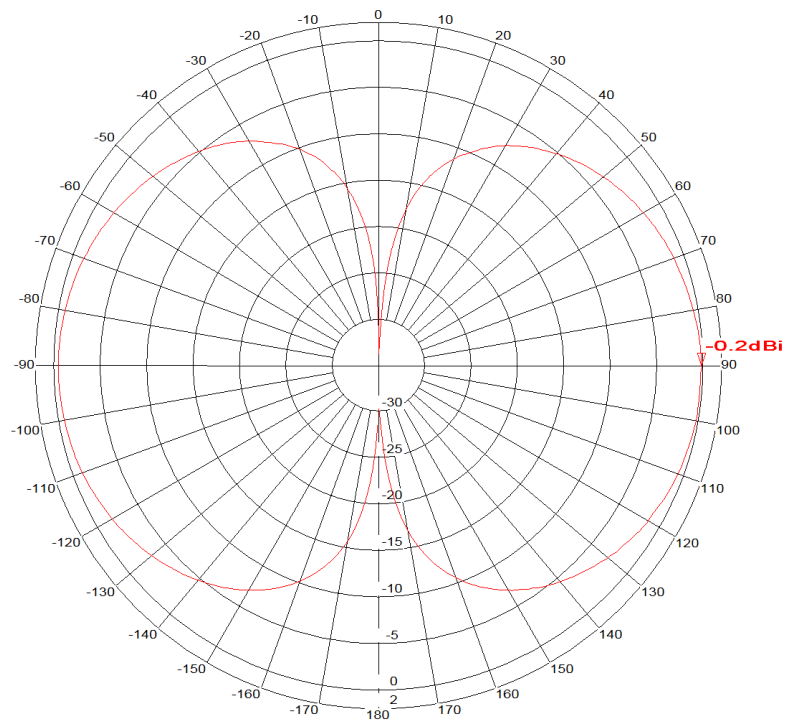

Frequency: 0.174 GHz

Figure 4: Azimuth & Elevation Gain Patterns @ 174 MHz

Issue : 1041

In the effort to improve our products, we reserve the right to make changes judged to be necessary.



X-ON Electronics

Largest Supplier of Electrical and Electronic Components

Click to view similar products for [Antennas](#) category:

Click to view products by [Radiall](#) manufacturer:

Other Similar products are found below :

[GAN30084EU](#) [930-033-R](#) [GW17.07.0250E](#) [1513563-1](#) [EXE902SM](#) [APAMPG-117](#) [MAF94383](#) [W3908B0100](#) [W6102B0100](#) [YE572113-30RSMM](#) [108-00014-50](#) [66089-2406](#) [SPDA17RP918](#) [A09-F8NF-M](#) [A09-F5NF-M](#) [RGFRA1903041A1T](#) [W3593B0100](#) [W3921B0100](#) [SIMNA-868](#) [SIMNA-915](#) [SIMNA-433](#) [W1044](#) [W1049B090](#) [A75-001](#) [WTL2449CQ1-FRSMM](#) [CPL9C](#) [EXB148BN](#) [0600-00060](#) [TRA9020S3PBN-001](#) [Y4503](#) [GD5W-28P-NF](#) [MA9-7N](#) [GD53-25](#) [GD5W-21P-NF](#) [C37](#) [MAF94051](#) [MA9-5N](#) [EXD420PL](#) [B1322NR](#) [QWFTB120](#) [MAF94271](#) [MAF94300](#) [GPSMB301](#) [FG4403](#) [AO-AGSM-OM54](#) [5200232](#) [MIKROE-2349](#) [WCM.01.0111](#) [MIKROE-2393](#) [MIKROE-2352](#)