

RIGHT ANGLE PLUG SOLDER TYPE
CABLE 2/50 + 2.6/50 + .085

R113.161.000

SERIES

MCX

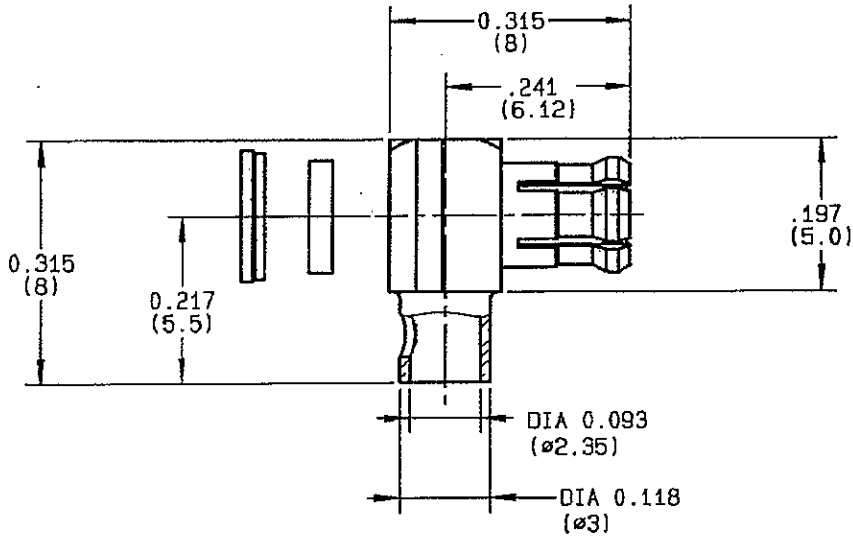

NOMINAL IMPEDANCE	50 Ω	CABLES : KS 1
FREQUENCY RANGE	0-6 GHz	KX 21
TEMPERATURE RATING	-55/+115 °C	KX 22A
V.S.W.R	- + 0 x F(GHz)Maxi	RG 174
RF INSERTION LOSS	NA \sqrt{F} (GHz) dB Maxi	RG 178
VOLTAGE RATING	- Veff Maxi	RG 188
DIELECTRIC WITHSTANDING VOLTAGE	- Veff Mini	RG 196
INSULATION RESISTANCE	1000 M Ω Mini	RG 316
HERMETIC SEAL	NA Atm.cm ³ /s	RG 405
LEAKAGE (pressurized only)	NA MPa	OTHERS CHARACTERISTICS
MECHANICAL DURABILITY	500 Cycles	CABLE RETENTION - N Mini
WEIGHT	gr	CENTER CONTACT RETENTION
SPECIFICATION		Axial force - mating end 10 N Mini
		Axial force - opposite end 10 N Mini
		Torque NA cm.N Mini
		RECOMMENDED TORQUES
		Mating NA cm.N
		Panel nut NA cm.N
		Clamp nut NA cm.N

CONNECTOR PARTS	MATERIALS	FINISH (all values are given in micrometers)
BODY	BRASS	GOLD 0.2 OVER NICKEL 2
OUTER CONTACT	BERYLLIUM COPPER	GOLD 0.5 OVER NICKEL 2
CENTER CONTACT	BRASS	GOLD 1.3 OVER NICKEL 2
INSULATOR	PTFE	-
GASKET		-
OTHERS PIECES		

ISSUE 0516 E	CREATION DATE 30-AUG-88	FILE PART-NUMBER
-----------------	----------------------------	------------------



The information given here is subject to change without notice. Design changes may be in order to improve the product.

Connect to the future

BAFI

VSWR	1.63	max
VOLTAGE RATING	170	Vrms max
DIELECTRIC WITHSTANDING VOLTAGE	500	Vrms min
STANDARDISATION	CECC 22 221 814	
CABLE RETENTION	7.05	lb min
	32	N min

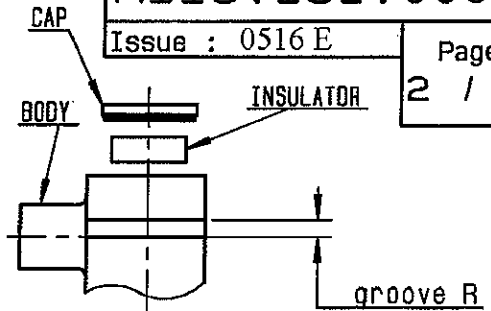

We recommend a thermal preconditioning cable

①

Strip the cable.
To return the braid.
Strip the dielectric.
To tin cable inner conductor.

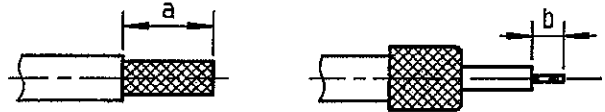

Stripping	a	b	c	d	e
inch	0.118	0.055	0	0	0
mm	3	1.4	-	-	-

②

To push the cable into the connector body until contact with it.
to solder the cable on the connector body.
To solder cable inner conductor into the centre contact.
To clean soldering area.

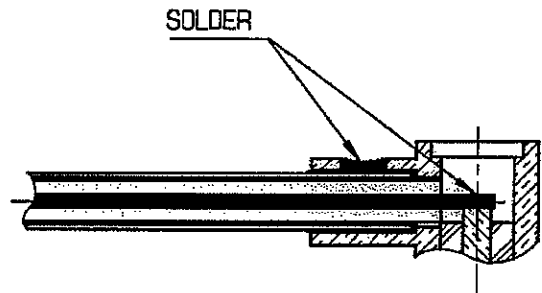

③

Introduce the insulator into the body.
Press fit the cap.

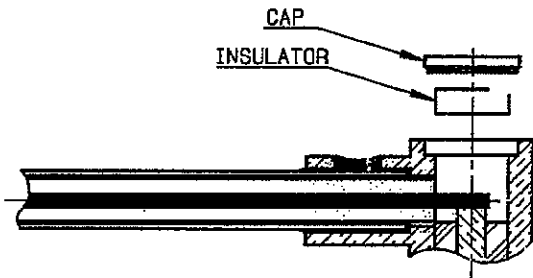

④

Slide mounting tool R282 868 onto the body grooves .
Press fit the cap turning tool handle with adapted wrench .275(AF) (cap in the same plan than square face) .

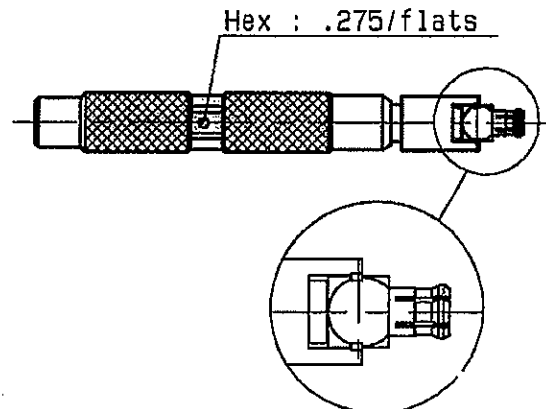

CABLE 2.6/50

R113.161.000

Issue : 0516 E

Page
3 / 4

VSWR	1.63	max
VOLTAGE RATING	335	Vrms max
DIELECTRIC WITHSTANDING VOLTAGE	750	Vrms min
STANDARDISATION	CECC 22 221-002	
CABLE RETENTION	11.925lb	min
	53	N min

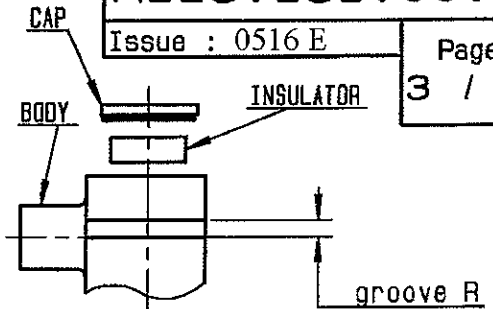

We recommend a thermal preconditioning cable

①

Strip the cable.
To tin cable inner conductor.

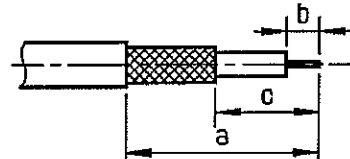

Stripping	a	b	c	d	e
inch	0.236	0.055	0.118	0	0
mm	6	1.4	3	-	-

②

To push the cable into the connector body until contact with it.
to solder the cable on the connector body.
To solder cable inner conductor into the centre contact.
To clean soldering area.

SOLDER



③

Introduce the insulator into the body.
Press fit the cap.

CAP
INSULATOR

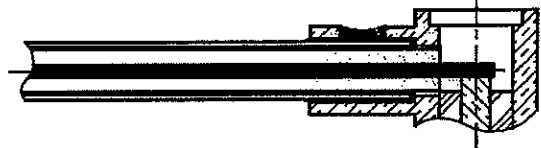

④

Slide mounting tool R282 868 onto the body grooves.
Press fit the cap turning tool handle with adapted wrench .275(AF) (cap in the same plan than square face).

Hex : .275/flats

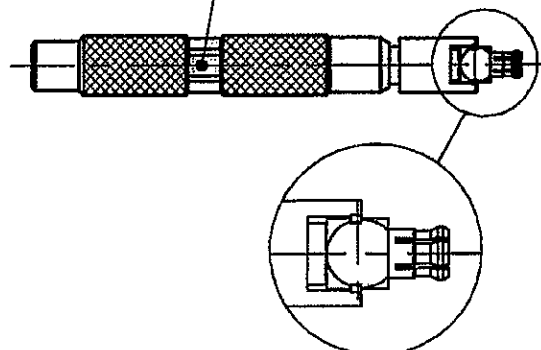

VSWR	1.63	max
VOLTAGE RATING	250	Vrms max
DIELECTRIC WITHSTANDING VOLTAGE	750	Vrms min
STANDARDISATION	CECC 22 221	MCX
CABLE RETENTION	34.875lb	min
	155	N min

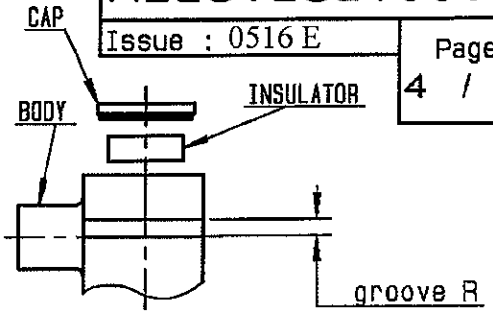

We recommend a thermal preconditioning cable

① Strip the cable.
To clean the cable.
To tin cable inner conductor.
-

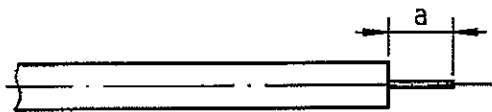

Stripping	a	b	c	d	e
inch	0.091	0	0	0	0
mm	2.3	-	-	-	-

② 1 -Introduce the positioner R282 864 000 and the cable into the connector body until contact with the body shoulder, place the sub assembly into the assembly jig R282 740 020 and tighten it.
2 -Solder body on the cable and let assembly cool down before removing it from the jig.
3 -To clean soldering area.
-

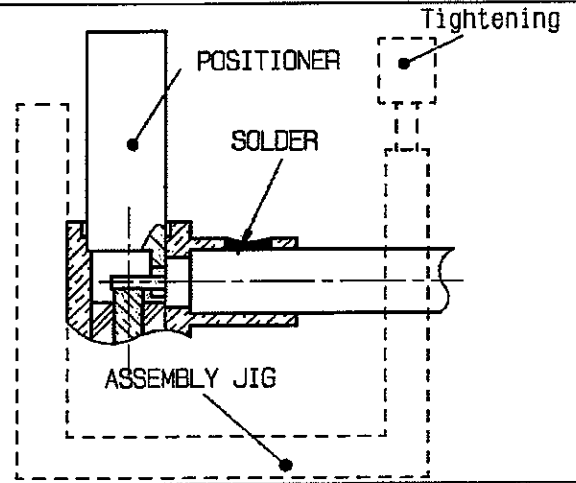

③ To solder cable inner conductor into the centre contact.
To clean soldering area.
Introduce the insulator into the body.
Press fit the cap.
-

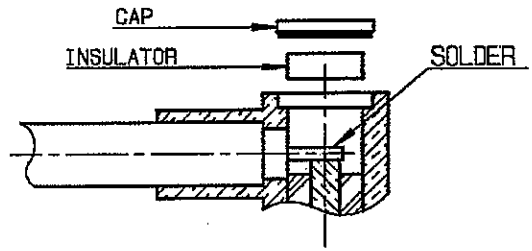

④ Slide mounting tool R282 868 onto the body grooves .
Press fit the cap turning tool handle with adapted wrench .275(AF) (cap in the same plan than square face) .
-

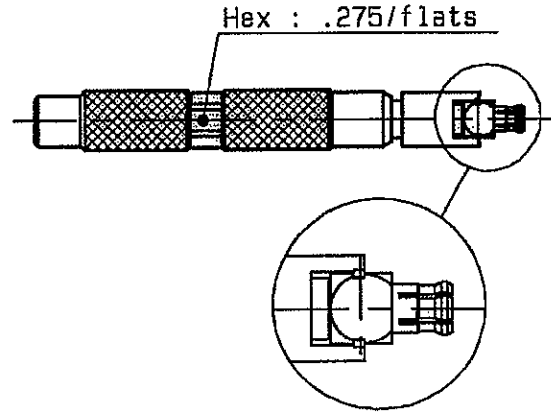

X-ON Electronics

Largest Supplier of Electrical and Electronic Components

Click to view similar products for [radiall](#) manufacturer:

Other Similar products are found below :

[5919-1503-000](#) [7101-1541-010](#) [7105-1561-010](#) [MD11-035](#) [81-6201-0450](#) [9074-9513-000](#) [R113425097](#) [R114305000W](#) [R124075210](#)
[R125055000](#) [R125512000W](#) [R141154000W](#) [R141572000](#) [R143012000](#) [R143235161W](#) [R166268000](#) [R176019000](#) [R191841001W](#)
[R282102000](#) [R282744220](#) [R282918120](#) [R404770000](#) [R413808000](#) [R414430150](#) [R414520150](#) [R433514700](#) [R570022105](#) [R570123005](#)
[R570363010](#) [R570442000](#) [R570E52010](#) [R574402410](#) [R585423230](#) [R114425000](#) [R124510000](#) [R125052500](#) [R125320020W](#) [R141331500W](#)
[R162017000W](#) [R176404000](#) [R191970091](#) [R282750000](#) [R317270000](#) [R404110150](#) [R404280150](#) [R404755000](#) [R413210150](#) [R413303150](#)
[R413830150](#) [R414530150](#)