

RIGHT ANGLE PLUG CRIMP TYPE

R223.183.000

CABLE 2.6/50 D

Series : MMBX

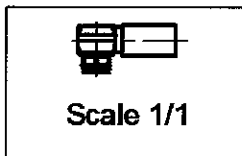
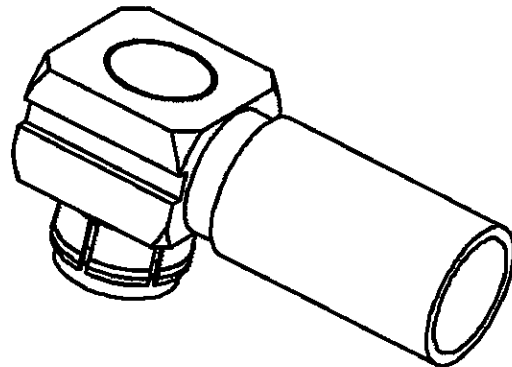
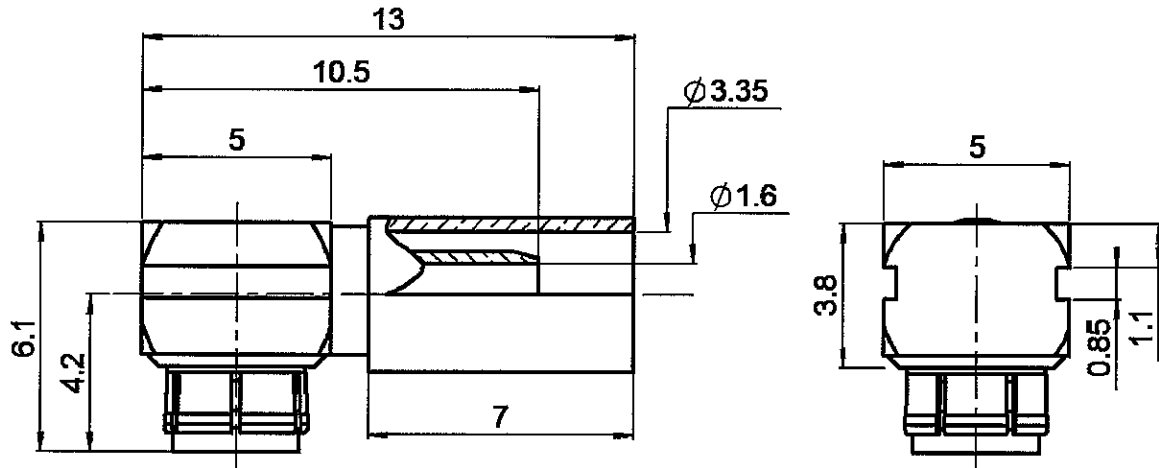

All dimensions are in mm.

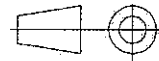

COMPONENTS	MATERIALS	PLATINGS (µm)
BODY	BRASS	GOLD 0.2 OVER NON MAGN NICKEL 2
CENTER CONTACT	BERYLLIUM COPPER, BRASS	GOLD 1.3 OVER NICKEL 2
OUTER CONTACT	BERYLLIUM COPPER	GOLD 0.2 OVER NON MAGN NICKEL 2
INSULATOR	PTFE	
GASKET		
OTHERS PARTS	BRASS	GOLD 0.2 OVER NON MAGN NICKEL 2
-	-	-
-	-	-

Issue : 0452 A

In the effort to improve our products, we reserve the right to make changes judged to be necessary.



RIGHT ANGLE PLUG CRIMP TYPE

R223.183.000

CABLE 2.6/50 D

Series : MMBX

PACKAGING

Standard	Unit	Other
100	'W' option	Contact us

SPECIFICATION

ELECTRICAL CHARACTERISTICS

Impedance		50 Ω
Frequency		0-12.4 GHz
VSWR	1.10 +	0.035 x F(GHz) Maxi
Insertion loss		0.18 √F(GHz) dB Maxi
RF leakage	- (100** - F(GHz)) dB Maxi
Voltage rating		250 Veff Maxi
Dielectric withstanding voltage		750 Veff mini
Insulation resistance		1000 MΩ mini

CABLE ASSEMBLY

Stripping	a	b	c	d	e	f
mm	2.00	4.50	9.50	0.00	7.50	0.00

Assembly instruction :

Recommended cable(s)
K02252D

Cable retention

- pull off **110** N mini
- torque **NA** N.cm

MECHANICAL CHARACTERISTICS

Center contact retention		
Axial force – Mating end	10	N mini
Axial force – Opposite end	10	N mini
Torque	NA	N.cm mini

Recommended torque		
Mating	NA	N.cm
Panel nut	NA	N.cm
Clamp nut	NA	N.cm
A/F clamp nut	0.000	mm

Mating life	100	Cycles mini
Weight	1.000	g

TOOLING

Part Number	Description	Hexagon
.	.	.
R282.235.906	CRIMPING DIES	3.3
R282.293.000	CRIMPING TOOL	
R282.868.000	EXTRACTION ASSEMBLY TOOL	

OTHERS CHARACTERISTICS

* to 6 GHz

** Interface MMBX only up to 2.5 GHz

ENVIRONMENTAL

Operating temperature	-55/+155°	°C
Hermetic seal	NA	Atm.cm3/s
Panel leakage	NA	

Issue : 0452 A

In the effort to improve our products, we reserve the right to make changes judged to be necessary.



RIGHT ANGLE PLUG CRIMP TYPE

R223.183.000

Series : MMBX

CABLE 2.6/50 D

COMPONENTS

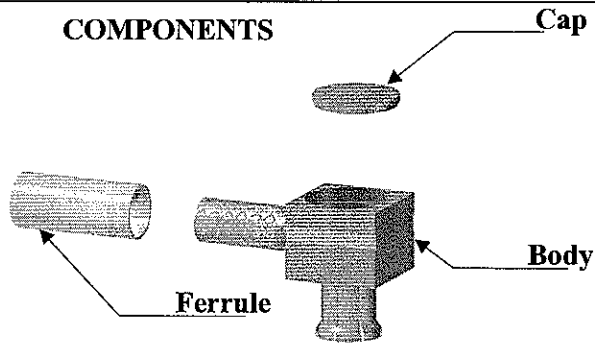

STRIPPING DIMENSIONS

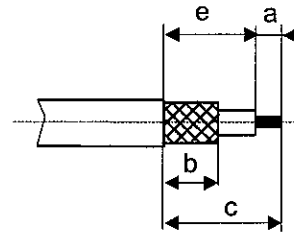

1

Slide the ferrule onto the cable.
Strip the cable.
Tin the cable inner conductor.

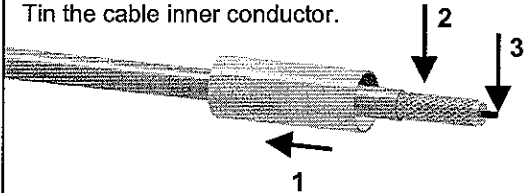

4

Crimp the ferrule with crimping tool (see connector TDS).
Solder the inner conductor.

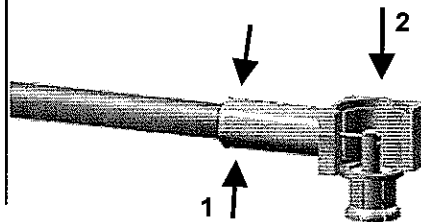

2

Fan the braid.

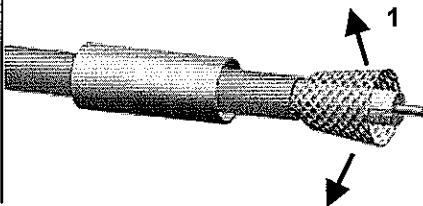

5

Place the insulator into the body.
Place the cap into the body.

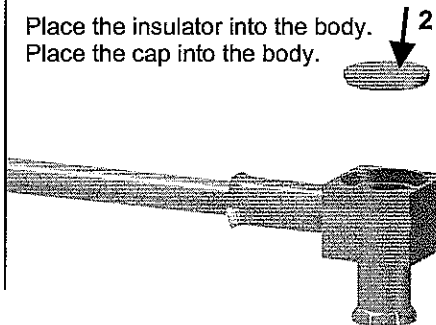

3

Push the connector body under the braid.
Slide the ferrule over the braid.

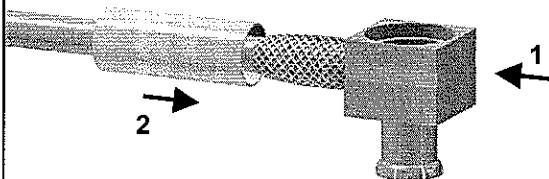

6

Slide mounting tool R282.868.000 onto the body grooves.
Drive the cap into rear opening of body by rotating the handle of the mounting tool.

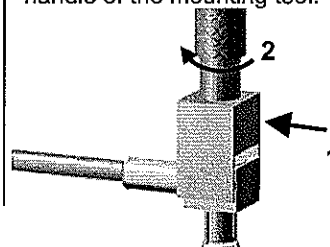

Issue : 0452 A

In the effort to improve our products, we reserve the right to make changes judged to be necessary.



X-ON Electronics

Largest Supplier of Electrical and Electronic Components

Click to view similar products for [RF Connectors / Coaxial Connectors](#) category:

Click to view products by [Radiall](#) manufacturer:

Other Similar products are found below :

[8915-1511-000](#) [89674-0827](#) [6001-7071-019](#) [6002-7051-003](#) [6002-7551-202](#) [6059674-1](#) [619550-1](#) [630059-000](#) [M39030/3-01N](#) [6500-7071-046](#) [6769](#) [CX050L2AQ](#) [7002-1541-010](#) [7002-1542-011](#) [7004-1512-000](#) [7009-1511-004](#) [7010-1511-000](#) [7029-1511-060](#) [7101-1541-010](#) [7101-1571-002](#) [7145-1521-002](#) [7203-1571-003](#) [7209-1511-011](#) [7210-1511-015](#) [7210-1511-019](#) [73137-5015](#) [73216-2241](#) [73404-2300](#) [7405-1521-005](#) [7405-1521-802](#) [8527](#) [8547](#) [FS11V](#) [877931](#) [8808-1511-001](#) [9049-9513-000](#) [9074-9513-000](#) [9101-9573-002](#) [910A205F](#) [9130-9573-002](#) [PL11SC-026](#) [PL375-33](#) [PL40-5](#) [PL74C-221](#) [PL75MC-217](#) [PL803-7](#) [1200690078](#) [1-201144-1](#) [R107003010W](#) [R110A172100](#)