

## Lora Wireless Module STM32WLE5 based

**RC-WLE5-868** is an ultra low power long range device designed by RadioControlli. The module is based on STM32WLE5JC device from STMicroelectronics.

Multiprotocol LPWAN 32bit Arm®Cortex® M4 MCUs, LoRa®, (G)FSK, (G)MSK, BPSK .

The main applications of this module are Internet of Things devices and wireless sensor networks , especially battery powered low power consumption long range.

Operative Frequency bands : 868MHz.

Ready for use SMD mounting (13 x 14.5mm) - Metal shield.

For more information and details, please refer to the STM32WLE5J datasheet ([www.st.com](http://www.st.com)).



Module Information :

**RC-WLE5-868** → Standard Version (UFL Connector)

**RC-WLE5-868-HA** → Helical Antenna Version

**RC-WLE5-868** is designed to be easily integrated into your hardware application, we provide 2 versions:

### 1) Standard version with UFL connector

You can use the UFL connector where you can directly connect the antenna. The RF output signal is also present on a 50 ohm pin (pin 15) in case you want to create your own antenna project on your pcb.

### 2) Version with helical antenna (full version)

#### Applications:

- Smart meters
- Wireless security systems
- Home and Building automation
- 6LoWPAN systems
- Automatic Measure Reading
- Low-Power Wireless Systems
- Wireless Sensor Networks
- Remote Control
- Street Lights System
- Parking Sensors
- Environmental Sensors
- Smart Grid and Automatic Meter Reading

## DESCRIPTION

The **RC-WLE5-XXX** long-range wireless and ultra-low-power devices embed a powerful and ultra-low-power radio compliant LPWAN radio solution : LORA (only available in STM32WLE5) , (G(FSK,(H)MSK and BPSK.

The devices embed high-speed memories (Flash memory up to 256 Kbytes, SRAM up to 64 Kbytes), and an extensive range of enhanced I/Os and peripherals. The devices also embed several protection mechanisms for embedded Flash memory and SRAM: readout protection, write protection and proprietary code readout protection. These devices offer a 12-bit ADC, a 12-bit DAC low-power sample-and-hold, two ultra-low-power comparators associated with a high-accuracy reference voltage generator. The devices embed a low-power RTC with a 32-bit sub-second wakeup counter , one 16-bit single-channel timer, two 16-bit four-channel timers (supporting motor control), one 32-bit four-channel timer and three 16-bit ultra-low-power timers.

**CORE** : STM32WLE5JC

**SIZE** : 14.5 x 13 x 2.8mm

## TECHNICAL CHARACTERISTICS

Characteristics		MIN	TYP	MAX	UNIT
V <sub>cc</sub>	Supply Voltage	2.5	3.3	3.7	Vdc
I <sub>s</sub>	Supply Current ( Sleep mode )		2.0		uA
I <sub>s1</sub>	Supply Current (Receive mode)		5.0		mA
I <sub>s2</sub>	Supply Current (Transmit mode)		120.0		mA
F	Frequency		868.0		Mhz
T	RF TX Power			18.5	dBm
S	RX Sensitivity		140		dBm
TE	Operating Temperature Range	-20		+70	°C

### BLOCK DIAGRAM

The module denominated RC-WLE5-XXX is based on STM32WL5Jx device which integrates :

- ARM Cortex M4 processor
- Sx126x LoRa transceiver on the same chip.

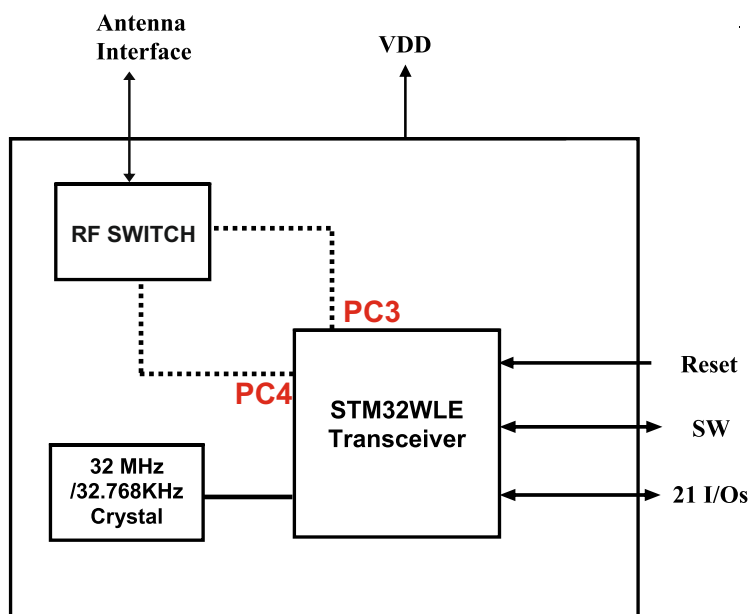

	PC3	PC4	RF Mode
RF Switch Control	1	0	TX
	0	1	RX

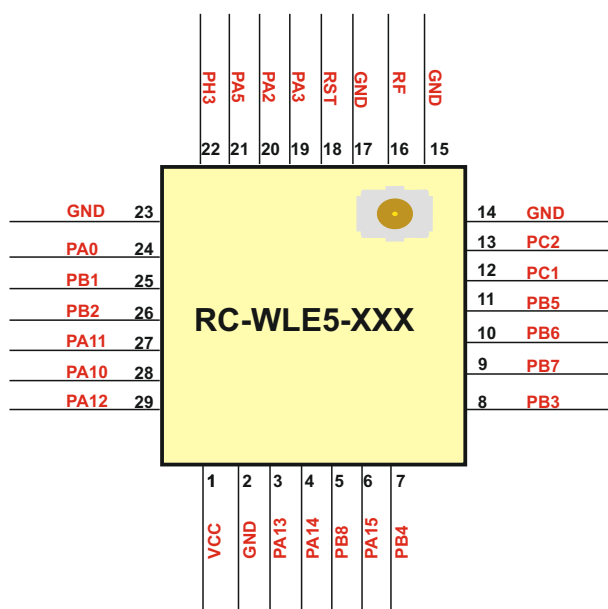
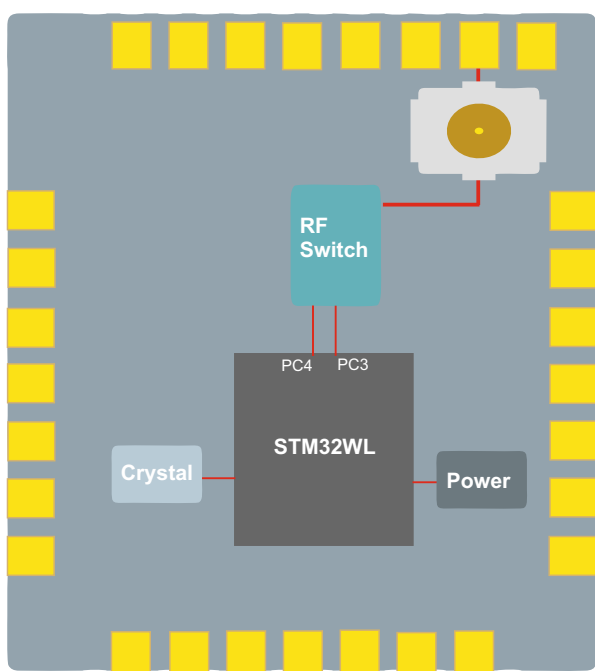

### PINOUT Main System Peripherals and GPIOs

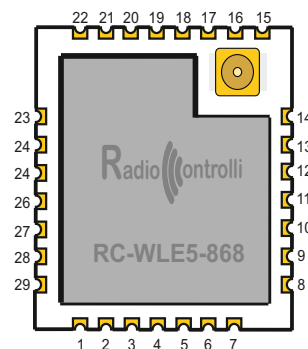
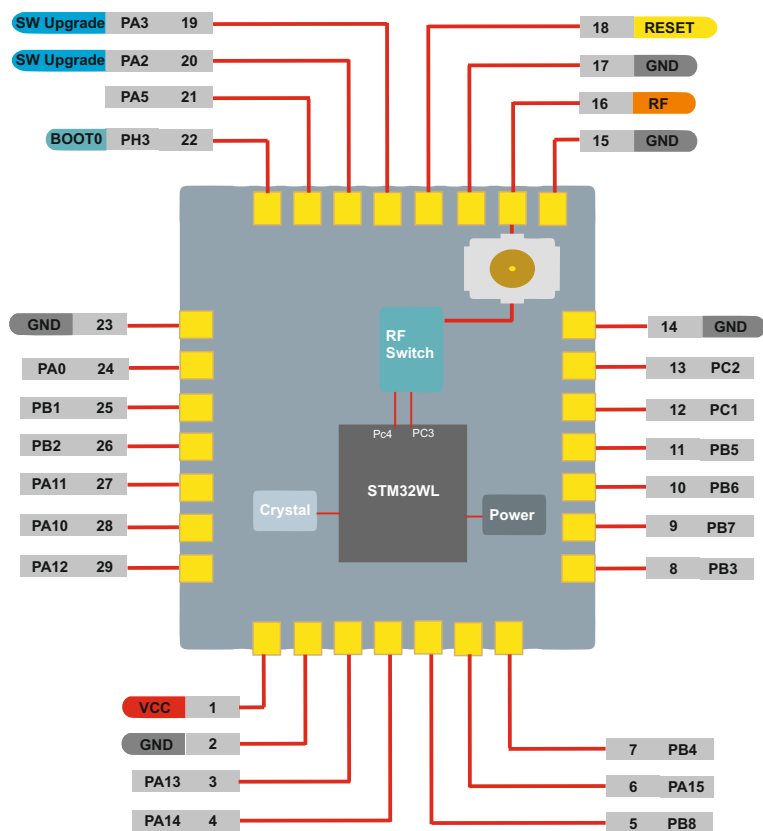

Standard Version

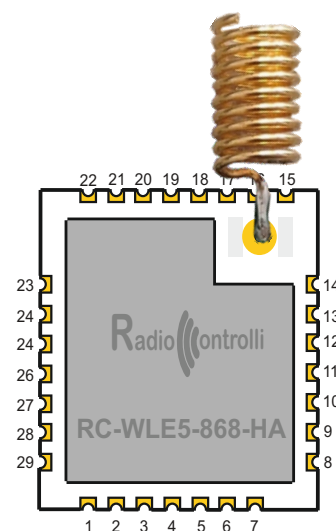

Helical Antenna Version

#### Pin Descriptions

Pin Number	Name	I/O	Description
01	VCC	-	Supply Voltage
02,14,15,17,23	GND	-	Ground
03	PA13	I/O	Input / Output pin
04	PA14	I/O	Input / Output pin
05	PB8	I/O	Input / Output pin
06	PA15	I/O	Input / Output pin
07	PB4	I/O	Input / Output pin
08	PB3	I/O	Input / Output pin
09	PB7	I/O	Input / Output pin
10	PB6	I/O	Input / Output pin
11	PB5	I/O	Input / Output pin
12	PC1	I/O	Input / Output pin
13	PC2	I/O	Input / Output pin
16	RF	O	Antenna RF Out
18	RST	I	Reset trigger input
19	PA3	I/O	USART2 RX - Input / Output / firmware upgrade
20	PA2	I/O	USART2 TX - Input / Output / firmware upgrade
21	PA5	I/O	Input / Output pin
22	PH3	I/O	BOOT0 - Startup Mode Selection
24	PA0	I/O	Input / Output pin
25	PB1	I/O	Input / Output pin
26	PB2	I/O	Input / Output pin
27	PA11	I/O	Input / Output pin
28	PA10	I/O	Input / Output pin
29	PA12	I/O	Input / Output pin

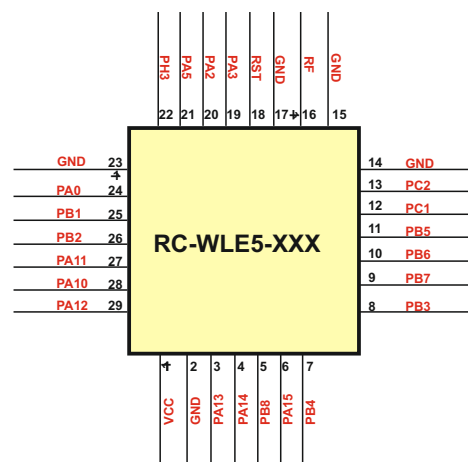

**REFERENCE SCHEMATICS**

**Software Upgrade through USART**

Normally BOOT0 (PH3) must be connected to GND

When is necessary to make an USART firmware upgrade, the BOOT0 (PH3) must be connected to VCC.

**Software Program through ST-LINK**

While programming through ST-LINK it's not necessary to connect BOOT0 to VCC.

**RF Switch Control**

The RF Switch that select the TX/RX of the module is controlled by the STM32WL5 using two GPIO (PC3 and Pc4). These GPIO aren't output in the module footprint, must be driven through the firmware (see table below).

	PC3	PC4	RF Mode
RF Switch Control	1	0	TX
	0	1	RX

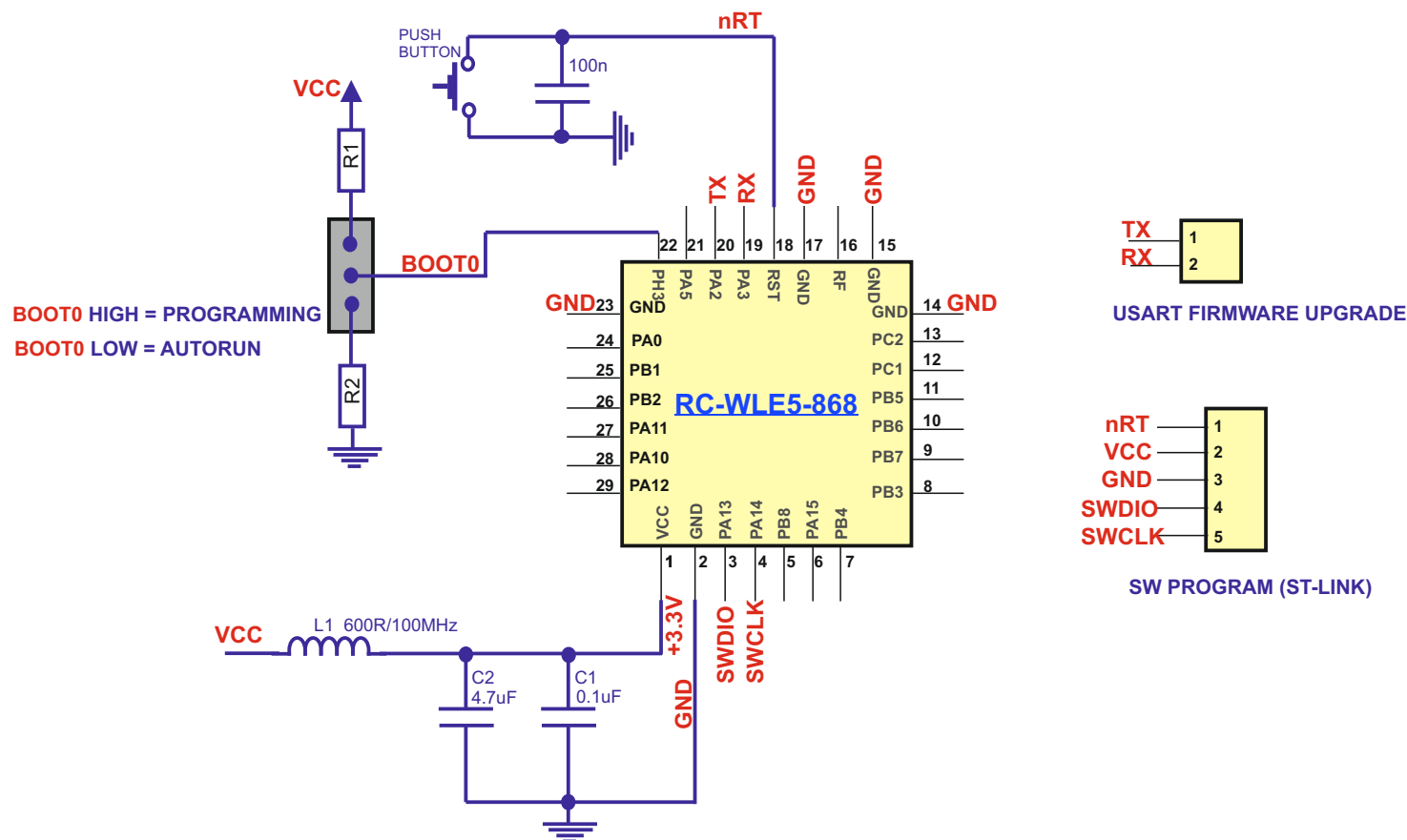

**VERSIONS:**

STANDARD Version = RC-WLE5-868

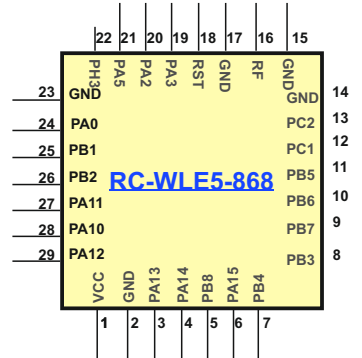
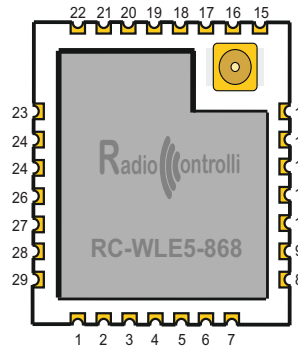

Antenna Connection through UFL connector

ANTENNA VERSION = RC-WLE5-868-HA

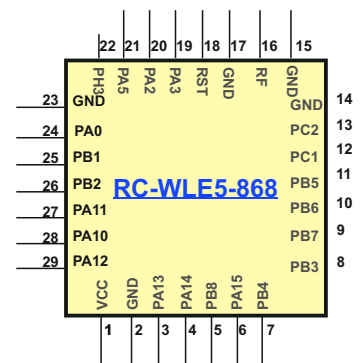
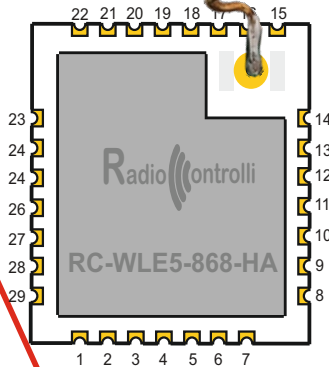

868MHz Helical Antenna

**MECHANICAL DIMENSIONS:**

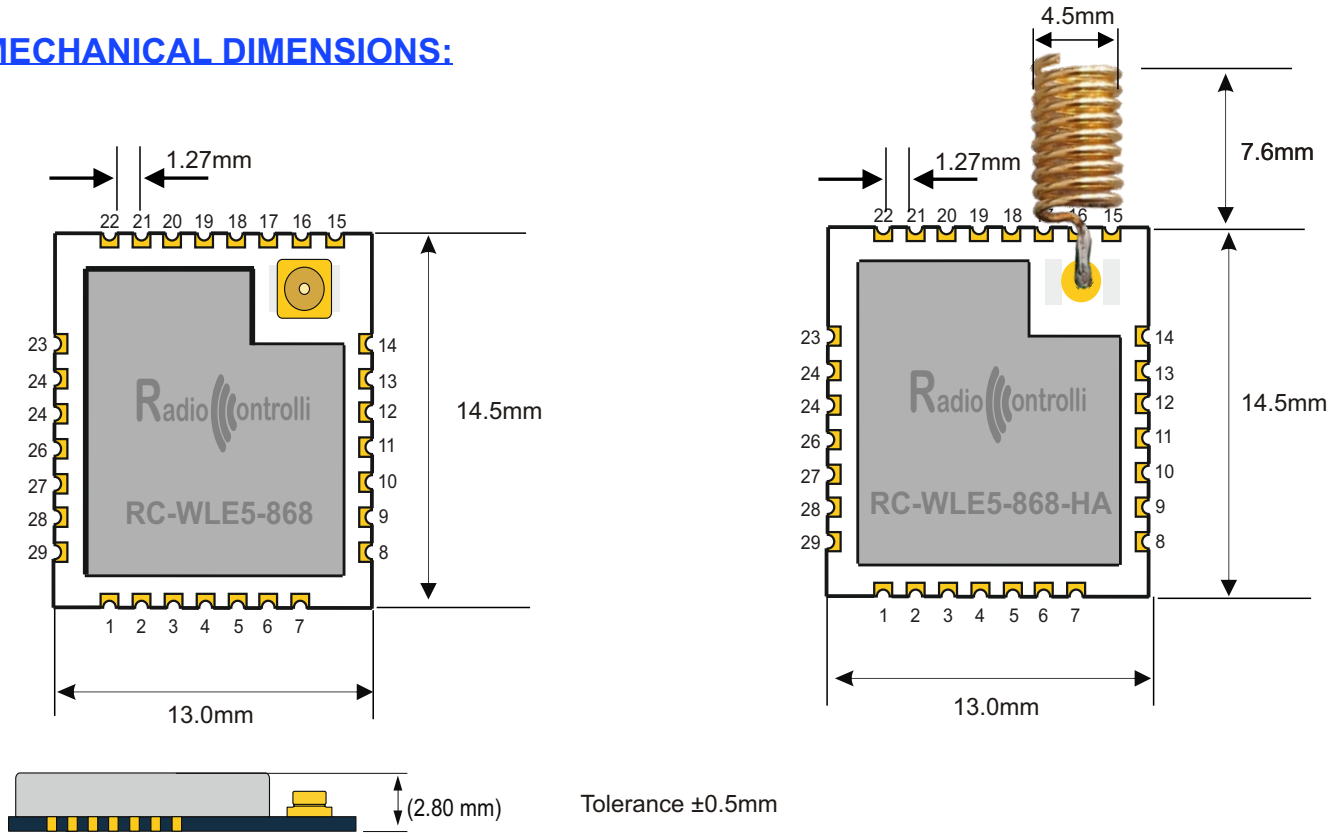

**RECOMMENDED PCB LAYOUT:**

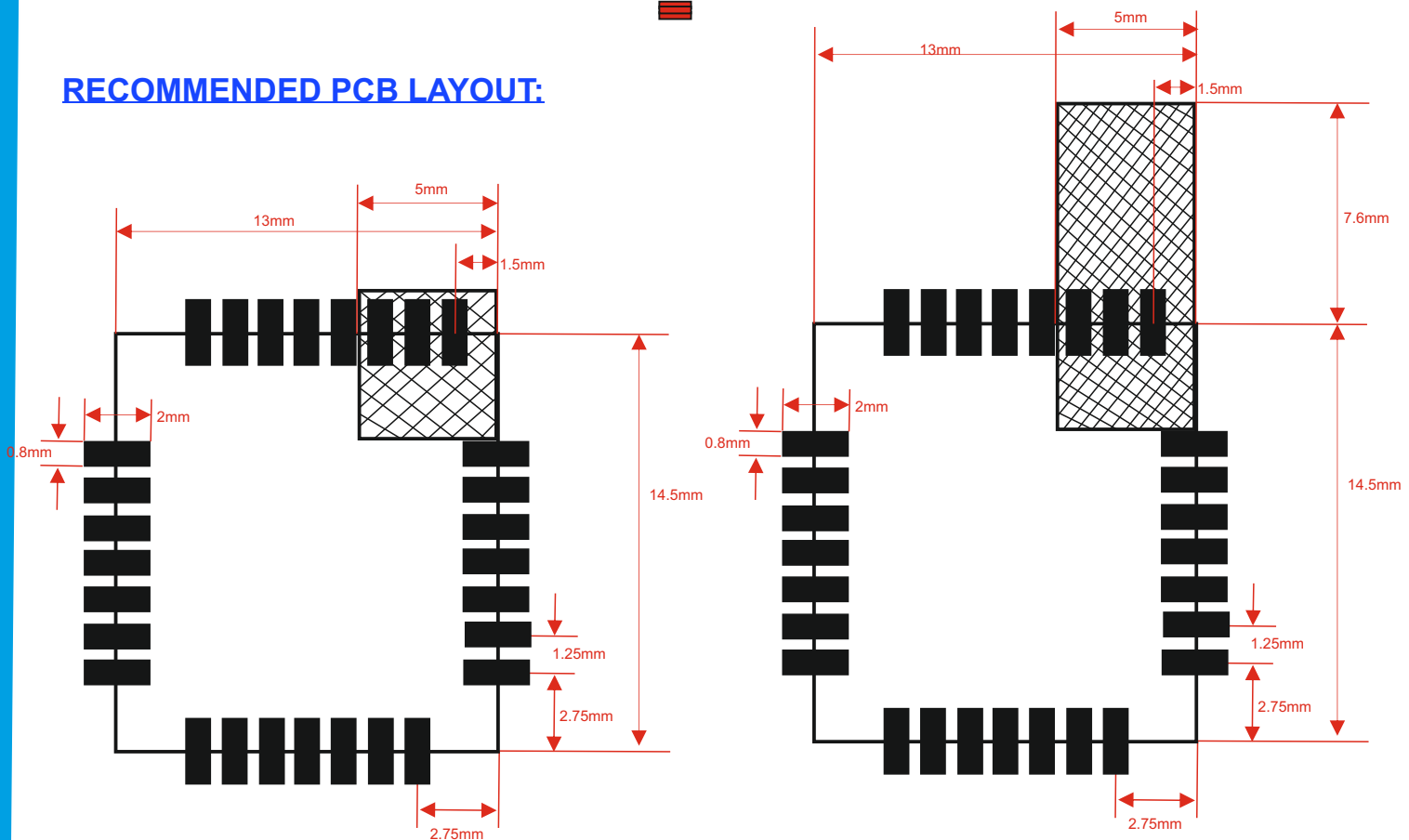

Note :  
Make sure in the shadow area shall without any wiring or ground.

## RECOMMENDED HARDWARE DESIGN:

### 1) Hardware

All unused pins should be left floating; do not ground.  
All GND pins must be well grounded.  
Traces should not be routed underneath the module.

### 2) Power Supply

The transceiver module must be powered from a regulated voltage.  
It is recommended to keep the power supply line for VCC as short and low impedance as possible. Near the power pins it is recommended to insert a ceramic the decoupling capacitor (100nF).

### 3) Ground Plane

It is recommended to have a copper ground plane under the shielded zone of the module. The ground plane should be unbroken and unified flood as possible especially on top and bottom layer.  
Use a lot of grounding vias as possible.  
Make sure there are no wires or earth in the shaded area, even better if this part isn't there (it's cut off).

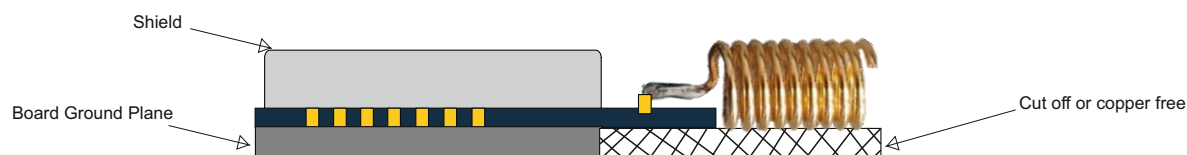
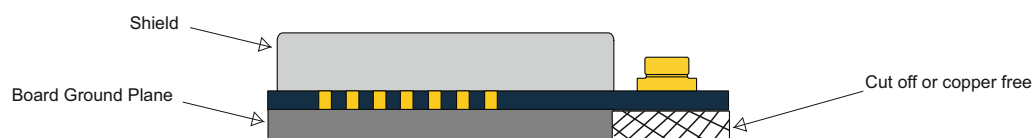



#### 4) Module Placement

The antenna on the PCB has an omnidirectional radiation pattern. To maximize antenna efficiency, an adequate grounding plane must be provided under the module. Instead the areas underneath and surrounding the antenna area must be free of copper.

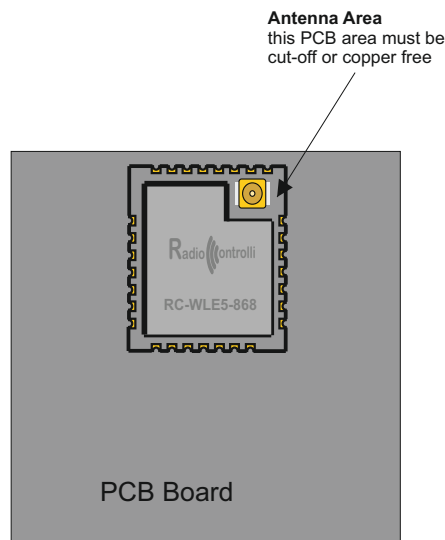

Recommended location XY plane

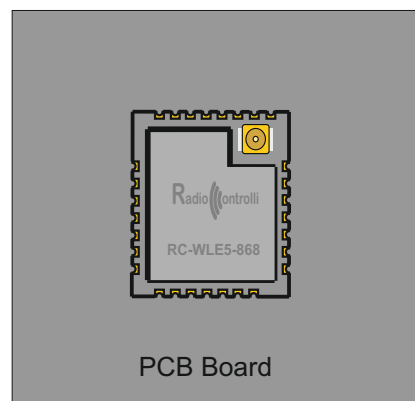

Not Recommended location XY plane

#### RECOMMENDED REFLOW PROFILE (LEAD FREE SOLDER)

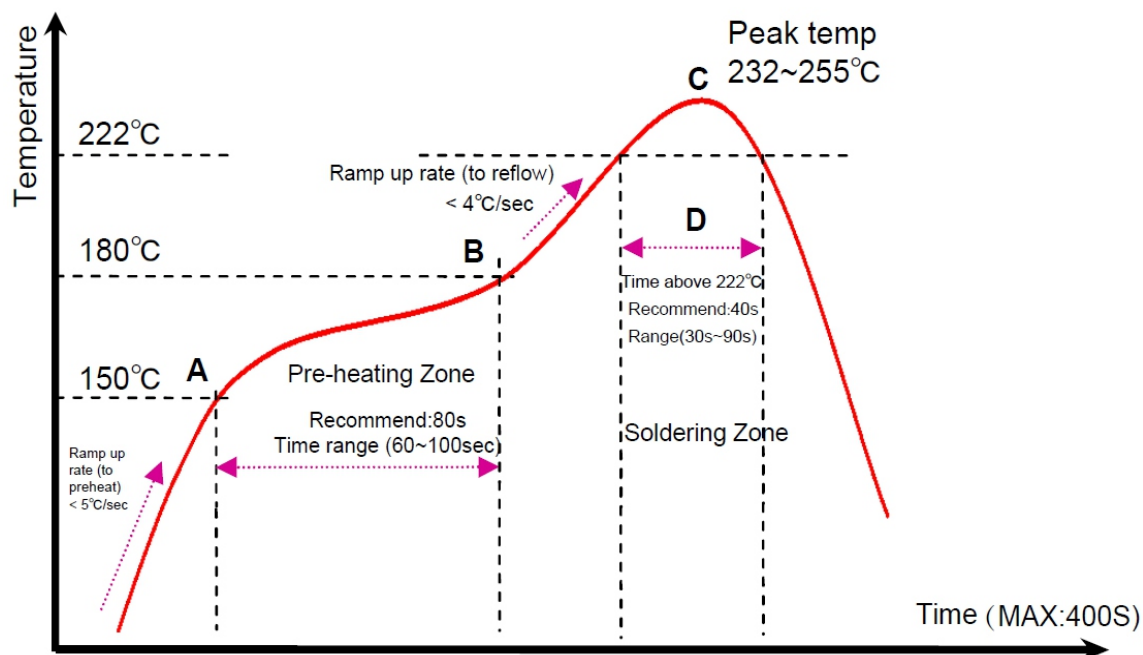

**PACKAGE**

TAPE AND REEL (Helical Antenna module exception)

Note : For package, we have three package types :

- Reel
- Tray
- Simple way for choosing

depend on customer's request or quantity request.

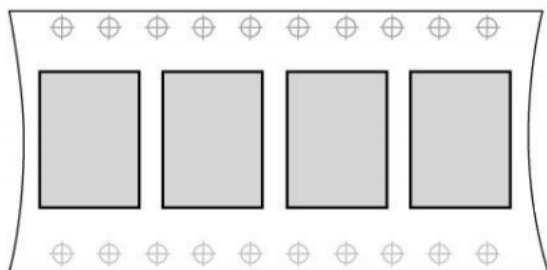
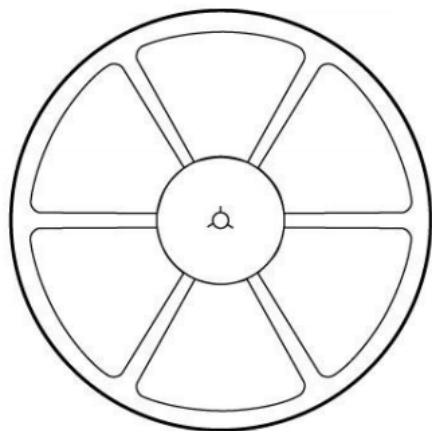

## X-ON Electronics

Largest Supplier of Electrical and Electronic Components

*Click to view similar products for [RF Modules](#) category:*

*Click to view products by [Radiocontrolli](#) manufacturer:*

Other Similar products are found below :

[2221706-1](#) [RAD-900-DAIO6](#) [650200791G](#) [650200714G](#) [RFM95PW-915S2](#) [VG2389S433N0S1](#) [VG6244S580X0M1](#) [RC-WLE5-868-HA](#)  
[RFM219BW-868S2](#) [E49-900M20S](#) [E01-2G4M27SX](#) [DL-297LDA-S](#) [DL-24PA-C](#) [DL-Si24R1-A](#) [VG3411S433N0S1](#) [HY831S](#) [TR1101](#)  
[VG4130S433N0S1](#) [VG4142T868N0M1](#) [VG3411S915N0S1](#) [E310-433T23S](#) [DL-PAN3029-S-915S](#) [DL-PAN3029-S-433S](#) [E01C-2G4M11S](#)  
[DL-PAN3029-S-868S](#) [E70-433MT14S](#) [E03-2G4M10S](#) [E01C-ML01S](#) [E01-2G4M13S](#) [E30-400M20S\(4463\)](#) [E49-400M30S](#) [E07-900MM10S](#)  
[E01-2G4M20S1B](#) [E70-900T14S](#) [E01C-ML01D](#) [E21-400G30S](#) [E07-900T10S](#) [E04-400M16S](#) [E01-ML01DP4](#) [E01-2G4M27S](#) [E27-433M20S](#)  
[E01-2G4M27D](#) [E01C-ML01SP4](#) [E01C-2G4M27SX](#) [E01-2G4M01S1B](#) [E07-400T10S](#) [E30-400M30S\(4463\)](#) [E01C-ML01DP4](#) [E310-433T23D](#)  
[E310-900T23D](#)