Raspberry Pi Compute Module 5

A Raspberry Pi for deeply embedded applications.

Colophon

© 2024 Raspberry Pi Ltd

This documentation is licensed under a Creative Commons [Attribution-NoDerivatives 4.0 International](#) (CC BY-ND).

build-date: 2024-11-27

build-version: b971495-clean

Legal disclaimer notice

TECHNICAL AND RELIABILITY DATA FOR RASPBERRY PI PRODUCTS (INCLUDING DATASHEETS) AS MODIFIED FROM TIME TO TIME ("RESOURCES") ARE PROVIDED BY RASPBERRY PI LTD ("RPL") "AS IS" AND ANY EXPRESS OR IMPLIED WARRANTIES, INCLUDING, BUT NOT LIMITED TO, THE IMPLIED WARRANTIES OF MERCHANTABILITY AND FITNESS FOR A PARTICULAR PURPOSE ARE DISCLAIMED. TO THE MAXIMUM EXTENT PERMITTED BY APPLICABLE LAW IN NO EVENT SHALL RPL BE LIABLE FOR ANY DIRECT, INDIRECT, INCIDENTAL, SPECIAL, EXEMPLARY, OR CONSEQUENTIAL DAMAGES (INCLUDING, BUT NOT LIMITED TO, PROCUREMENT OF SUBSTITUTE GOODS OR SERVICES; LOSS OF USE, DATA, OR PROFITS; OR BUSINESS INTERRUPTION) HOWEVER CAUSED AND ON ANY THEORY OF LIABILITY, WHETHER IN CONTRACT, STRICT LIABILITY, OR TORT (INCLUDING NEGLIGENCE OR OTHERWISE) ARISING IN ANY WAY OUT OF THE USE OF THE RESOURCES, EVEN IF ADVISED OF THE POSSIBILITY OF SUCH DAMAGE.

RPL reserves the right to make any enhancements, improvements, corrections or any other modifications to the RESOURCES or any products described in them at any time and without further notice.

The RESOURCES are intended for skilled users with suitable levels of design knowledge. Users are solely responsible for their selection and use of the RESOURCES and any application of the products described in them. User agrees to indemnify and hold RPL harmless against all liabilities, costs, damages or other losses arising out of their use of the RESOURCES.

RPL grants users permission to use the RESOURCES solely in conjunction with the Raspberry Pi products. All other use of the RESOURCES is prohibited. No licence is granted to any other RPL or other third party intellectual property right.

HIGH RISK ACTIVITIES. Raspberry Pi products are not designed, manufactured or intended for use in hazardous environments requiring fail safe performance, such as in the operation of nuclear facilities, aircraft navigation or communication systems, air traffic control, weapons systems or safety-critical applications (including life support systems and other medical devices), in which the failure of the products could lead directly to death, personal injury or severe physical or environmental damage ("High Risk Activities"). RPL specifically disclaims any express or implied warranty of fitness for High Risk Activities and accepts no liability for use or inclusions of Raspberry Pi products in High Risk Activities.

Raspberry Pi products are provided subject to RPL's [Standard Terms](#). RPL's provision of the RESOURCES does not expand or otherwise modify RPL's [Standard Terms](#) including but not limited to the disclaimers and warranties expressed in them.

Table of contents

Colophon	1
Legal disclaimer notice	1
1. Introduction	4
1.1. Introduction	4
1.2. Features	5
2. Interfaces	7
2.1. Wireless	7
2.1.1. WL_nDisable	7
2.1.2. BT_nDisable	7
2.2. Ethernet	8
2.3. PCIe (Gen2 ×1)	8
2.4. USB 3.0 (Super speed)	9
2.5. USB 2.0 (High speed)	9
2.6. GPIO	9
2.6.1. Alternative function assignments	10
2.7. Alternate GPIO functions	13
2.8. Dual HDMI 2.0	13
2.9. MIPI (DSI / CSI-2)	14
2.10. CAM_GPIO (CAM_GPIO0 CAM_GPIO1)	14
2.11. I2C (SDA0 SCL0)	14
2.12. I2C (ID_SD ID_SC)	14
2.13. SDIO/eMMC (CM5Lite only)	15
2.14. USB-C (CC0 CC1)	15
2.15. Fan control (Fan_PWM Fan_Tacho)	15
2.16. PMIC_EN	16
2.17. PWR_BUT	16
2.18. VBAT	16
2.19. nRPI_BOOT	16
2.20. LED_nACT	16
2.21. LED_nPWR	16
2.22. EEPROM_nWP	17
2.23. Debug UART	17
3. Electrical and mechanical	18
3.1. Mechanical	18
3.2. Thermal	19
3.3. Electrical specification	19
4. Pinout	23
4.1. Differential pairs	29
4.1.1. 100Ω differential pair signal lengths	29
4.1.2. 90Ω differential pair signal lengths	31
5. Power	32
5.1. Power-up sequencing	32
5.2. Power-down sequencing	32
5.3. Power consumption	32
5.4. Regulator outputs	32
Appendix A: Troubleshooting	33
Hardware checklist	33
Bootloader	33
rpi-eeeprom-update	33
EEPROM write-protect	33
Firmware	34
Kernel	34
Appendix B: Test Points	35
Test Points	35
Powering Vin	37

Debug UART	37
RPI Boot	37
Ethernet Boot	37
Appendix C: Differences between CM4 and CM5	38
Pinout changes	38
Track lengths	39
Power budget	39
Appendix D: Availability	41
Support	41
Order codes	41
Packaging	42
Appendix E: Mean Time Between Failure (MTBF)	43
Appendix H: Documentation Release History	44
27 November 2024	44

Chapter 1. Introduction

1.1. Introduction

Figure 1. The front of Raspberry Pi Compute Module 5 (CM5).

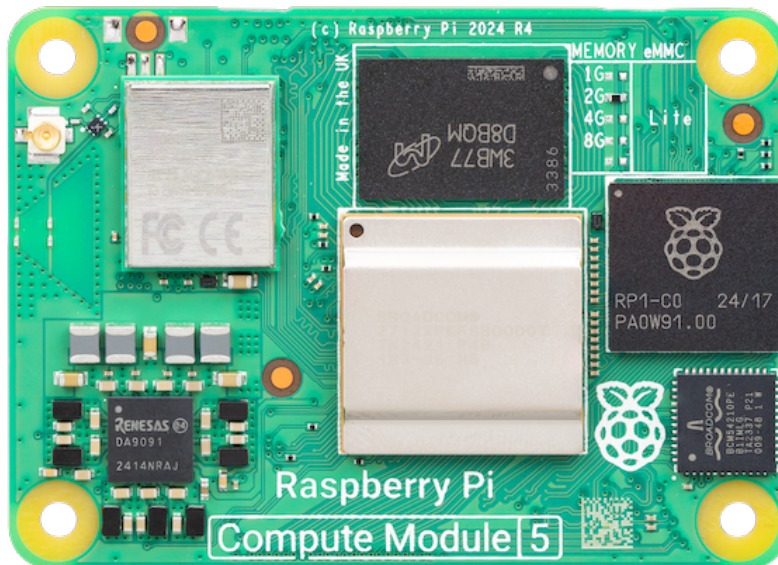
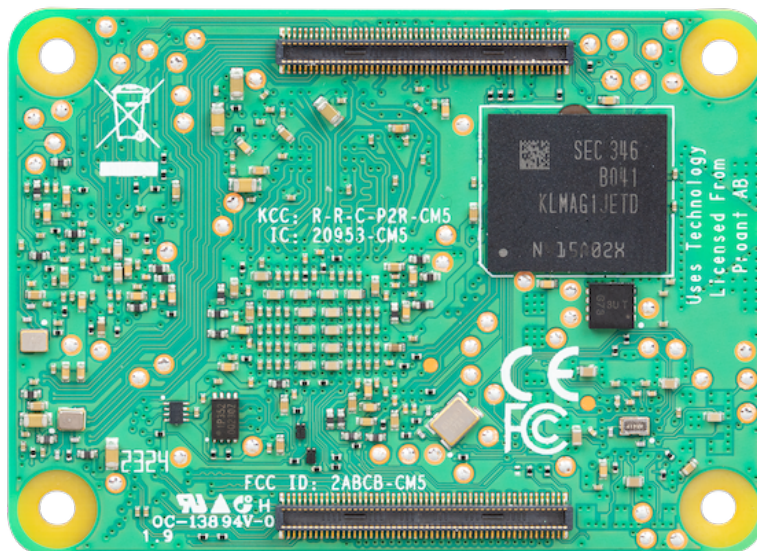

Figure 2. The back of Raspberry Pi Compute Module 5 (CM5).



The Raspberry Pi Compute Module 5 (CM5) is a System on Module (SoM) containing processor, memory, eMMC Flash, and supporting power circuitry. These modules allow a designer to leverage the Raspberry Pi hardware and software stack in their own custom systems and form factors. In addition, these modules have extra IO interfaces over and above what is available on the Raspberry Pi boards, opening up more options for the designer.

The design of the CM5 is loosely based on the Raspberry Pi 5, and for cost-sensitive applications it can be supplied without the eMMC fitted; this version is called the Raspberry Pi Compute Module 5 Lite (CM5Lite).

The new CM5 and CM5Lite are mostly compatible with the previous generation of compute module. The previous generation of compute modules are still for sale and will remain in production till at least January 2034. The electrical interface of the CM5 is via two 100-pin high density connectors.

The main change in pinout is to support the addition of 2 USB 3.0 ports.

i NOTE

Unless otherwise stated, within this document CM5 also refers to CM5Lite.

1.2. Features

Key features of the CM5 are as follows:

- Broadcom [BCM2712](#), quad core Cortex-A76 (ARMv8) 64-bit SoC @ 2.4GHz
- Small Footprint 55mm × 40mm × 4.7mm module
 - 4 × M2.5 mounting holes
- 4kp60 HEVC decoder
- OpenGL ES 3.1 graphics, Vulkan 1.2
- Options for 2GB, 4GB, or 8GB LPDDR4-4267 SDRAM with ECC (see [Appendix D](#))
- Options for 0GB (**CM5Lite**), 16GB, or 32GB eMMC flash memory (see [Appendix D](#))
 - Peak eMMC bandwidth 400MBps (four times as faster as previous Compute Modules)
- Option (see [Appendix D](#)) for certified radio module with:
 - 2.4 GHz, 5.0 GHz IEEE 802.11 b/g/n/ac wireless
 - Bluetooth 5.0, BLE
 - On board electronic switch to select between PCB trace or external antenna
- Gigabit Ethernet PHY supporting IEEE 1588
- 1 × PCIe 1-lane Host, Gen 2 (5Gbps)
- 1 × USB 2.0 port (high speed)
- 2 × USB 3.0 ports, supporting simultaneous 5Gbps operation
- up to 30 × GPIO supporting either 1.8V or 3.3V signalling and peripheral options:
 - Up to 5 × UART
 - Up to 5 × I2C
 - Up to 5 × SPI
 - 1 × SDIO interface
 - 1 × DPI (parallel RGB display)
 - 1 × I2S
 - Up to 4× PWM channels
 - Up to 3× GPCLK outputs
- 2 × HDMI 2.0 ports (supports up to 4Kp60 on each port simultaneously)
- 2 × 4-lane MIPI ports
 - supporting both DSI (display port) and CSI-2 (camera port)

- 1 × SDIO 2.0 (**CM5Lite**)
- Single +5V PSU input supports USB PD for up to 5A @ 5V
- Real-time clock (RTC), powered from external battery

Chapter 2. Interfaces

2.1. Wireless

The CM5 can be supplied with an on-board wireless module based on the Cypress CYW43455 supporting both:

- 2.4 GHz, 5.0 GHz IEEE 802.11 b/g/n/ac wireless
- Bluetooth 5.0, BLE

These wireless interfaces can be individually enabled or disabled as required. For instance, in the case of a kiosk application, a service engineer could enable wireless operation and then disable it once finished.

The CM5 has an on-board antenna. If used it should be positioned in the product such that it is not surrounded by metal, including any ground plane (see [Chapter 3](#) for further details). Alternatively there is a standard U.FL connector on the module, see [Figure 1](#), so that an external antenna can be used.

Raspberry Pi Ltd has an antenna kit which is certified to be used with the CM5. If you use a different antenna, separate certification is required.

⚠ WARNING

Raspberry Pi Ltd does not assist with certification for third-party antennas.

Antenna selection (internal or external) happens at boot time using the `config.txt` file. During operation, this selection cannot be changed. Append one of the following lines to `config.txt` to select an antenna:

- `dtparam=ant1` selects the internal antenna
- `dtparam=ant2` selects the external antenna

2.1.1. WL_nDisable

This pin serves a number of functions;

1. It can be used to monitor the enable/disable state of wireless networking. A logic high means the wireless networking module is powered up.
2. When driven or tied low it prevents the wireless network module from powering up. This is useful to reduce power consumption or in applications where it is required to physically ensure the wireless networking is disabled. If the interface is enabled after being disabled, you must reinitialise the wireless interface driver.

i NOTE

On CM5 modules without wireless, this pin is reserved.

2.1.2. BT_nDisable

This pin serves a number of functions;

1. It can be used to monitor the enable/disable state of Bluetooth. A logic high means the Bluetooth module is powered up.
2. When driven, or tied low, it prevents the Bluetooth module from powering up. This is useful to reduce power consumption, or in applications where it is required to physically ensure the Bluetooth is disabled. If the interface is enabled after being disabled, you must reinitialise the Bluetooth interface driver.

NOTE

On CM5 modules without wireless, this pin is reserved.

2.2. Ethernet

The CM5 has an on-board Gigabit Ethernet PHY – the Broadcom [BCM54210PE](#) – some of the major features of this PHY include;

- [IEEE 1588-2008](#) compliant
- MDI crossover, pair skew and pair polarity correction

A standard 1:1 RJ45 MagJack is all that is necessary to provide an Ethernet connection to the CM5. Typical wiring of a MagJack supporting PoE, and with added ESD protection, can be seen in [Figure 3](#).

Figure 3. Ethernet schematic interface for the Raspberry Pi Compute Module 5 supporting PoE, and with added ESD protection.

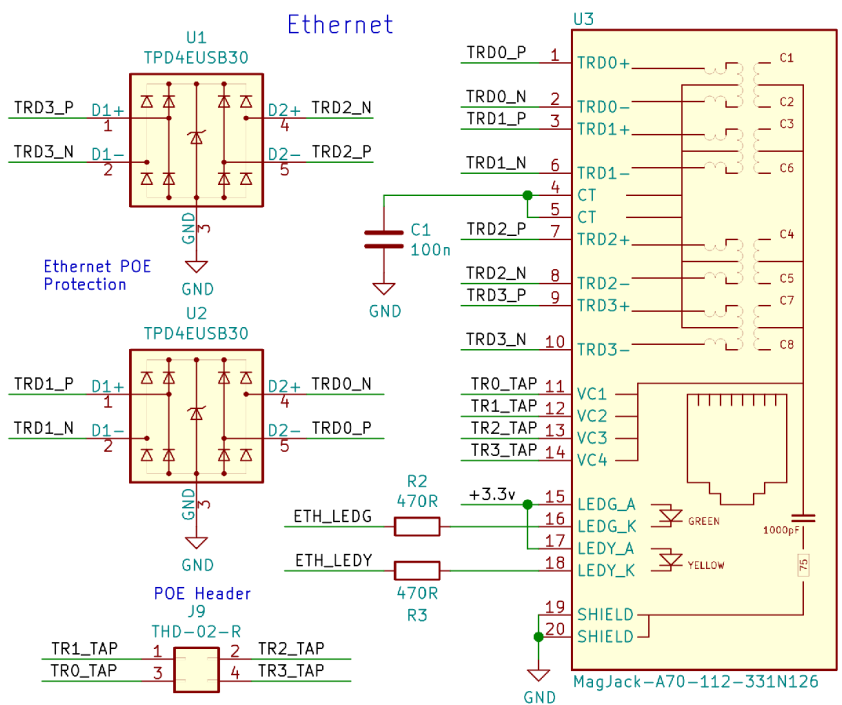

The differential Ethernet signals should be routed as 100Ω differential pairs, with suitable clearances. Length matching between pairs should be better than 50mm, so in the typical case no length matching is required. However the signals within a pair need to be length matched, ideally to better than 0.15mm.

The PHY also supports up to 2 LEDs to give user status feedback, these are active-low. These LEDs can have a range of functions, and you should consult your OS driver to see which functions are supported by your driver.

The PHY also provides `SYNC_OUT` at 3.3V signalling to support [IEEE 1588-2008](#). This pin can be defined as an input if required.

2.3. PCIe (Gen2 ×1)

The CM5 has an internal PCIe 2.0 ×1 host controller. It may be used as Gen 3.0, but this mode is unsupported and may not work in all cases.

⊖ WARNING

You should ensure that there is a suitable OS driver for any host controller that is chosen before proceeding to a prototype.

Connecting a PCIe device follows the standard PCIe convention. The CM5 has on-board AC coupling capacitors for the **PCIe_TX** signals. However the **PCIe_RX** signals need external coupling capacitors close to the driving source (the device TX), if you are using an external PCIe/NVMe card these capacitors will be on-board. The PCIe convention is that if you are wiring directly to an IC then the TX and RX pairs need to be swapped (i.e. TX → RX, RX → TX). If you are wiring to a connector then this is typically labelled from the host point of view and so TX/RX swaps aren't required. Additionally the **PCIe_CLK_nREQ** must be connected to ensure the CM5 produces a clock signal, and the **PCIe_nRST** should also be connected to ensure the device is correctly reset when required. **PCIe_nWAKE** signal is also available, but isn't currently supported in software.

The differential PCIe signals should be routed as 90Ω differential pairs, with suitable clearances. There is no need to match the lengths between pairs, only the signals within a pair need to be length matched ideally to better than 0.1mm.

2.4. USB 3.0 (Super speed)

Each USB 3.0 interface supports up to 5Gb/s signalling simultaneously. The differential pair should be routed as a 90Ω differential pair. There is no need to match the lengths between pairs, only the signals within a pair need to be length matched, ideally to less than 0.1mm. The P/N signals of the USB 3 signals may be P and N swapped. The USB 2 pairs can't be P/N swapped.

2.5. USB 2.0 (High speed)

The USB 2.0 interface supports up to 480Mbps signalling. The differential pair should be routed as a 90Ω differential pair. The length of the P/N signals should ideally be matched to better than 0.15mm.

💡 TIP

To enable the USB interface use the `dtoverlay=dwc2,dr_mode=host` setting in the `config.txt` file.

i NOTE

The port is capable of being used as a true USB On-The-Go (OTG) port. While there is no official documentation, some users have had success making this work. The **USB_OTG_ID** pin is used to select between USB host and device that is typically wired to the ID pin of a Micro USB connector. To use this functionality it must be enabled in the OS. If using either as a fixed slave or fixed master, please tie the **USB_OTG_ID** pin to ground.

2.6. GPIO

There are 28 pins available for general purpose I/O (GPIO), which correspond to the GPIO pins on the Raspberry Pi 5 40-pin header. These pins have access to internal peripherals: SMI, DPI, I2C, PWM, SPI, and UART. The [RP1 peripherals datasheet](#) describes these features along with the multiplexing options available. The drive strength and slew rate should ideally be set as low as possible to reduce any EMC issues. GPIO2 and GPIO3 have 1.8kΩ pull-up resistors.

The GPIO bank is powered by **GPIO_VREF**, this can either be connected to **CM5_1.8V** for 1.8V signalling GPIO, or **CM5_3.3V** for 3.3V signalling. You should keep the load on the 28 GPIO pins to below 50mA in total. **GPIO_VREF** must be powered for the CM5 to start up correctly. +2.5V signalling is possible if an external +2.5V supply is used for **GPIO_VREF**. This external supply should only be active while **CM5_1.8v** is on, the 2.5V supply will need to be discharged within 1ms of the **CM5_1.8v**

going low.

2.6.1. Alternative function assignments

Up to six alternative functions are available. The table below gives a quick overview.

Table 1. GPIO function selection

GPIO	Function								
	a0	a1	a2	a3	a4	a5	a6	a7	a8
0	SPI0_SIO[3]	DPI_PCLK	UART1_TX	I2C0_SDA		SYS_RIO[0]	PROC_RIO[0]	PIO[0]	SPI2_CS[0]
1	SPI0_SIO[2]	DPI_DE	UART1_RX	I2C0_SCL		SYS_RIO[1]	PROC_RIO[1]	PIO[1]	SPI2_SIO[1]
2	SPI0_CS[3]	DPI_VSYNC	UART1_CTS	I2C1_SDA	UART0_IR_RX	SYS_RIO[2]	PROC_RIO[2]	PIO[2]	SPI2_SIO[0]
3	SPI0_CS[2]	DPI_HSYNC	UART1_RTS	I2C1_SCL	UART0_IR_TX	SYS_RIO[3]	PROC_RIO[3]	PIO[3]	SPI2_SCLK
4	GPCLK[0]	DPI_D[0]	UART2_TX	I2C2_SDA	UART0_RI	SYS_RIO[4]	PROC_RIO[4]	PIO[4]	SPI3_CS[0]
5	GPCLK[1]	DPI_D[1]	UART2_RX	I2C2_SCL	UART0_DTR	SYS_RIO[5]	PROC_RIO[5]	PIO[5]	SPI3_SIO[1]
6	GPCLK[2]	DPI_D[2]	UART2_CTS	I2C3_SDA	UART0_DCD	SYS_RIO[6]	PROC_RIO[6]	PIO[6]	SPI3_SIO[0]
7	SPI0_CS[1]	DPI_D[3]	UART2_RTS	I2C3_SCL	UART0_DSR	SYS_RIO[7]	PROC_RIO[7]	PIO[7]	SPI3_SCLK
8	SPI0_CS[0]	DPI_D[4]	UART3_TX	I2C0_SDA		SYS_RIO[8]	PROC_RIO[8]	PIO[8]	SPI4_CS[0]
9	SPI0_SIO[1]	DPI_D[5]	UART3_RX	I2C0_SCL		SYS_RIO[9]	PROC_RIO[9]	PIO[9]	SPI4_MISO
10	SPI0_SIO[0]	DPI_D[6]	UART3_CTS	I2C1_SDA		SYS_RIO[10]	PROC_RIO[10]	PIO[10]	SPI4_MOSI
11	SPI0_SCLK	DPI_D[7]	UART3_RTS	I2C1_SCL		SYS_RIO[11]	PROC_RIO[11]	PIO[11]	SPI4_SCLK
12	PWM0[0]	DPI_D[8]	UART4_TX	I2C2_SDA	AUDIO_OUT_L	SYS_RIO[12]	PROC_RIO[12]	PIO[12]	SPI5_CS[0]
13	PWM0[1]	DPI_D[9]	UART4_RX	I2C2_SCL	AUDIO_OUT_R	SYS_RIO[13]	PROC_RIO[13]	PIO[13]	SPI5_SIO[1]
14	PWM0[2]	DPI_D[10]	UART4_CTS	I2C3_SDA	UART0_TX	SYS_RIO[14]	PROC_RIO[14]	PIO[14]	SPI5_SIO[0]
15	PWM0[3]	DPI_D[11]	UART4_RTS	I2C3_SCL	UART0_RX	SYS_RIO[15]	PROC_RIO[15]	PIO[15]	SPI5_SCLK
16	SPI1_CS[2]	DPI_D[12]			UART0_CTS	SYS_RIO[16]	PROC_RIO[16]	PIO[16]	
17	SPI1_CS[1]	DPI_D[13]			UART0_RTS	SYS_RIO[17]	PROC_RIO[17]	PIO[17]	
18	SPI1_CS[0]	DPI_D[14]	I2S0_SCLK	PWM0[2]	I2S1_SCLK	SYS_RIO[18]	PROC_RIO[18]	PIO[18]	GPCLK[1]
19	SPI1_SIO[1]	DPI_D[15]	I2S0_WS	PWM0[3]	I2S1_WS	SYS_RIO[19]	PROC_RIO[19]	PIO[19]	
20	SPI1_SIO[0]	DPI_D[16]	I2S0_SDI[0]	GPCLK[0]	I2S1_SDI[0]	SYS_RIO[20]	PROC_RIO[20]	PIO[20]	
21	SPI1_SCLK	DPI_D[17]	I2S0_SDO[0]	GPCLK[1]	I2S1_SDO[0]	SYS_RIO[21]	PROC_RIO[21]	PIO[21]	

	Function								
22	SDIO0_CLK	DPI_D[18]	I2S0_SDI[1]	I2C3_SDA	I2S1_SDI[1]	SYS_RIO[22]	PROC_RIO[22]	PIO[22]	
23	SDIO0_CMD	DPI_D[19]	I2S0_SDO[1]	I2C3_SCL	I2S1_SDO[1]	SYS_RIO[23]	PROC_RIO[23]	PIO[23]	
24	SDIO0_DAT[0]	DPI_D[20]	I2S0_SDI[2]		I2S1_SDI[2]	SYS_RIO[24]	PROC_RIO[24]	PIO[24]	SPI2_CSn[1]
25	SDIO0_DAT[1]	DPI_D[21]	I2S0_SDO[2]	AUDIO_IN_CLK	I2S1_SDO[2]	SYS_RIO[25]	PROC_RIO[25]	PIO[25]	SPI3_CSn[1]
26	SDIO0_DAT[2]	DPI_D[22]	I2S0_SDI[3]	AUDIO_IN_DAT0	I2S1_SDI[3]	SYS_RIO[26]	PROC_RIO[26]	PIO[26]	SPI5_CSn[1]
27	SDIO0_DAT[3]	DPI_D[23]	I2S0_SDO[3]	AUDIO_IN_DAT1	I2S1_SDO[3]	SYS_RIO[27]	PROC_RIO[27]	PIO[27]	SPI1_CSn[1]

Each GPIO can have one function selected at a time. Likewise, each peripheral input (e.g. I2C3_SCL) should only be selected on one GPIO at a time. If the same peripheral input is connected to multiple GPIOs, the peripheral sees the logical OR of these GPIO inputs.

NOTE

Function selections without a named function in this list are reserved.

2.7. Alternate GPIO functions

- 5× UARTs
 - 4 with 4 wire interface (TX, RX, CTS, RTS)
 - UART0 also supporting 8 wire interface (TX, RX, CTS, RTS, DTR, DCD, DSR, RI) or IrDA (IR_TX, IR_RX)
- 1× SDIO (4 bit)
- 4× PWMs
- 1× I2S, Master (I2S0), quadruple lane
- 1× I2S, Slave (I2S1), quadruple lane
- 2× AUDIO_OUT PWM Audio which requires buffering using a low PSU noise buffer and filtered with an 22KHz 1st order RC network.
- 2× AUDIO_IN : Digital PDM input
- 2× GPCLK Clock outputs
- 1× DPI (Digital Display Interface) (PCLK, DE, VSYNC, HSYNC and up to 24bit data)
- 28× GPIO (SYS_RIO)
- 4× I2C (SDA, SCL)
- SPI:

Instance ID	Master/Slave	Chip-select count	Max I/O width
SPI0	M	4	Quad
SPI1	M	3	Dual
SPI2	M	2	Dual
SPI3	M	2	Dual
SPI4	S	1	Single
SPI5	M	2	Dual

For conventional SPI connections on SIO[0] is MOSI and SIO[1] is MISO. The other SIO pins aren't required.

2.8. Dual HDMI 2.0

CM5 supports two HDMI 2.0 interfaces, each one capable of driving a 4K display.

HDMI signals should be routed as 100Ω differential pairs. Each signal within a pair should ideally be matched to better than 0.15mm. Pairs don't typically need any extra matching, as they only have to be matched to 25mm.

CEC is also supported; an internal 27kΩ pull-up resistor is included in the CM5.

Internal pull-up resistors for the EDID signals is provided. On the Raspberry Pi 5 the HDMI signals don't have any extra

ESD protection. Depending on the application, extra ESD protection may be required.

2.9. MIPI (DSI / CSI-2)

The CM5 supports two 4-lane MIPI interfaces. Each MIPI interface can either be DSI (Display) or CSI (Camera). The MIPI signals should be routed as 100Ω differential pairs. Each signal within a pair should ideally be matched to better than 0.15mm.

The documentation around the CSI interface can be found in the [Raspberry Pi documentation](#). CM5 supports DSI displays supported by the official Raspberry Pi firmware or the Linux kernel tree; for other DSI displays, you must provide a custom driver.

i NOTE

The official Raspberry Pi firmware supports the OmniVision OV5647, Sony IMX219, Sony IMX296, Sony IMX477 and Sony IMX708 camera sensors. No security device is required on Compute Module devices in order to use these camera sensors.

i NOTE

You can also add displays using the parallel DPI interface, available as a GPIO alternative function. CM5 supports up to three displays of any type (HDMI, DSI, DPI) at any one time.

2.10. CAM_GPIO (CAM_GPIO0 CAM_GPIO1)

CAM_GPIO0 is typically routed to pin 17 on the camera connector to turn the power on and off on a camera module. **CAM_GPIO1** is a new signal not present on previous compute modules. It is recommend to route this to pin 18 on the camera connector for future expansion. These pins are actually GPIO pins on RP1, **CAM_GPIO0** is GPIO34 and **CAM_GPIO1** is GPIO35

2.11. I2C (SDA0 SCL0)

This internal I2C bus is normally allocated to MIPI0. It can be used as a general I2C bus if MIPI0 interface isn't being used. SDA0 is connected to GPIO38 on the RP1 and SCL0 is connected to GPIO39.

2.12. I2C (ID_SD ID_SC)

This I2C bus is normally used for identifying HATs and controlling CSI0 and DSI0 devices. If the firmware isn't using the I2C bus e.g. MIPI1 isn't being used then these pins may be used as GPIO 0 and GPIO 1 if required.

i NOTE

If these pins are used as GPIO pins, then to prevent the firmware from checking to see if there is a HAT EEPROM available, add `force_eeprom_read=0` and `disable_poe_fan=1` to the `config.txt` file.

2.13. SDIO/eMMC (CM5Lite only)

CM5Lite does not have onboard eMMC. eMMC signals are available on the connector, enabling the use of an external eMMC or SD card.

The `SD_PWR_ON` signal enables an external power switch to power the SD card. To boot from an SD card, fit a pull-up resistor, which turns the power switch on by default.

For eMMC, set `SD_VDD_OVERRIDE` to high (`CM5_3.3V`) to force 1.8V signalling on the SDIO interface.

NOTE

SD cards require a power switch controlled by `SD_PWR_ON` as that is the only way to reset the SD card.

Figure 4. CM5Lite SD card interface.

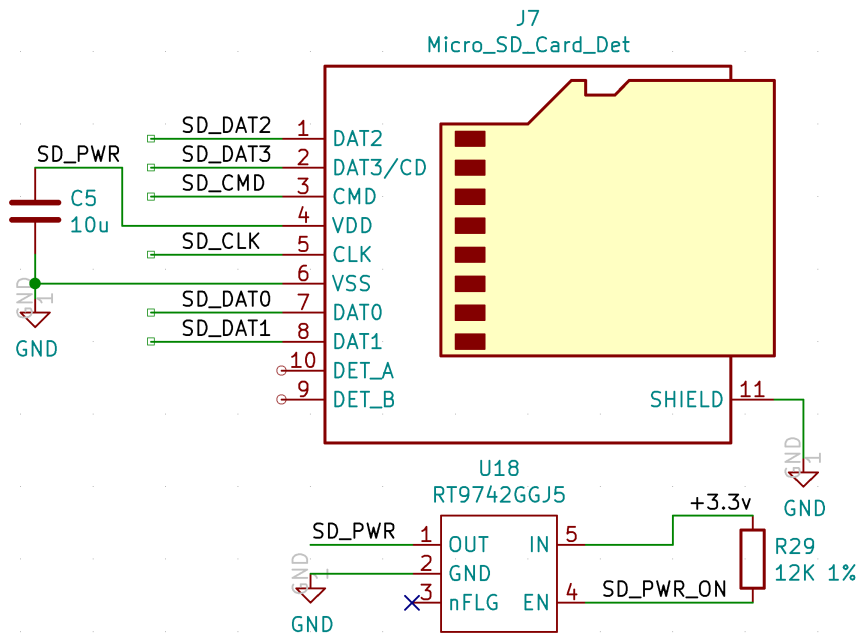

2.14. USB-C (CC0 CC1)

`CC0` and `CC1` are signals that are used on a USB-C connector for negotiation of power. CM5 will use these signals to try and negotiate 5V @ 5A.

2.15. Fan control (Fan_PWM Fan_Tacho)

CM5 provides two pins for PWM fan control. `Fan_PWM` is an open collector output suitable for connecting to a wide variety of PWM fans. `Fan_Tacho` is an input with an internal pull-up to `CM5_3.3V` suitable for Tacho output from many PWM fans.

i NOTE

During CM5 shutdown, power supply shutdown includes `Fan_PWM`. If the PWM fan is powered from +5V, the fan will start or continue to run. To prevent the fan from running after power supply shutdown, turn off the supply to the fan. For example, you could use the same supply as the external USB ports use which is controlled by `VBUS_EN`. Alternatively, use an open collector buffer (e.g. 74LVC1G07) powered from +5V. Connect the input to `CM5_3.3V`. Connect the output in parallel with the PWM line.

2.16. `PMIC_EN`

Pulling this pin low puts the CM5 in the lowest possible power-down state.

💡 TIP

It is recommended to only pull this pin low once the OS has shut down.

2.17. `PWR_BUT`

Pulling this pin low will either power up the CM5 if it has previously been shut down, or power down the CM5 if held low. This signal is typically connected to a button to function as a power button. If `PWR_EN` is low for longer than 5 seconds the CM5 will be forced shutdown.

2.18. `VBAT`

This is a 2.7 to 3V power input that powers the onboard RTC. While the CM5 is operating, there is a small static load. When the CM5 is not operating, the load increases to power the RTC. A typical CR2032 battery should last for over three years when the CM5 is unpowered.

2.19. `nRPI_BOOT`

During boot if this pin is low, booting from eMMC will be stopped and booting will be transferred to rpi boot which is via USB2.

2.20. `LED_nACT`

This pin is designed to drive an LED to replicate the green LED on the Raspberry Pi 5. Under Linux this pin will flash to signify eMMC access. If any error occurs during booting, then this LED will flash an error pattern which can be decoded using the [lookup table](#) in the Raspberry Pi documentation.

2.21. `LED_nPWR`

This pin needs to be buffered to drive an LED. The signal is designed to replicate the red LED on the Raspberry Pi 5. When the board is powered, but shut down, the LED lights up.

2.22. EEPROM_nWP

It is recommended that final products pull this pin low to prevent the end users changing the contents of the on-board EEPROM. See the Raspberry Pi 5 documentation for instructions on the software settings required to support [EEPROM write protection](#).

2.23. Debug UART

Space is provided for the user to fit a debug UART connector. This connector provides the same functionality as Raspberry Pi 5. The connector is a three-pin 1mm pitch JST-SH connector, Part number [BM03B-SRSS-TB](#). The signals are replicated on the bottom as test points.

Chapter 3. Electrical and mechanical

3.1. Mechanical

The CM5 is a compact 40mm × 55mm module. The Module is 4.6mm deep, but when connected the height will be 4.94mm or 7.44mm depending on the stacking height chosen.

1. 4 × M2.5 mounting holes (inset 3.5mm from module edge)
2. PCB thickness 1.24mm ± 10%
3. [BCM2712](#) SoC height including solder balls 2.2 ± 0.15mm
4. Stacking height either:
 - a. 1.5mm with mating connector (clearance under CM5 0mm): Amphenol P/N 10164227-1001A1RLF.
 - b. 4.0mm with mating connector (clearance under CM5 2.5mm): Amphenol P/N 10164227-1004A1RLF.

i NOTE

For additional information see the [CM5 design files](#).

If the onboard wireless antenna is used (see [Section 2.1](#)) it must be orientated towards the edge of the plastic enclosure and any nearby metal must have cut-outs or the wireless performance will be degraded. It is suggested that there is at least 10mm clearance around the PCB antenna, but the designer must check the performance.

Figure 5. Mechanical specification of the Raspberry Pi Compute Module 5

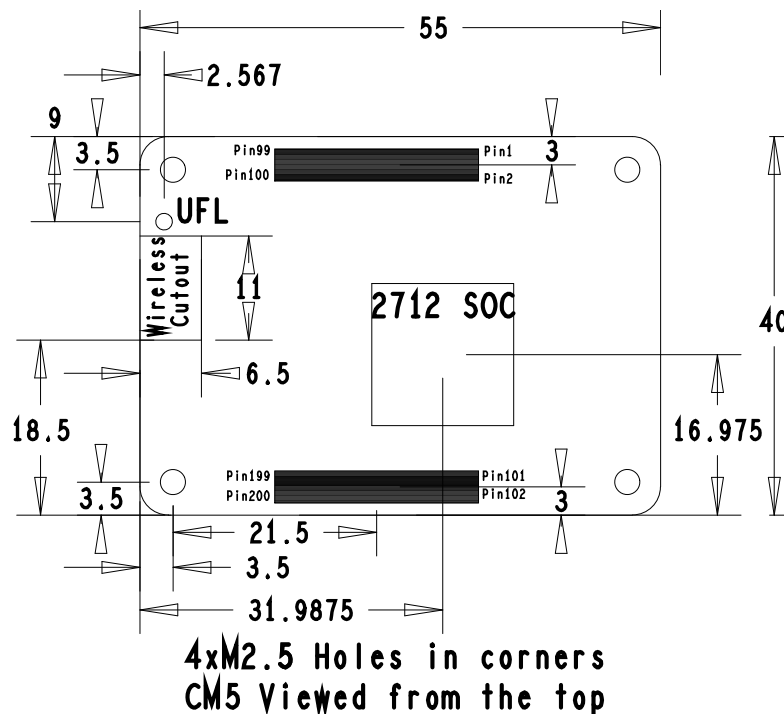

There must not be any metal, including ground planes, under the antenna. The ground plane cutout must be a minimum of 6.5mm × 11mm, but ideally at least 8mm × 15mm. If these requirements can't be met wireless performance may be degraded, especially in the 2.4GHz spectrum. It is recommended that the external antenna is used where possible.

i NOTE

The location and arrangement of components on the Compute Module may change slightly over time due to revisions for cost and manufacturing considerations; however the maximum component heights and PCB thickness will be kept as specified.

A step file of the CM5 is available as part of the CM5 design data package. This is for guidance only and is subject to changes over time due to revisions.

3.2. Thermal

The CM5 contains less metal in the PCB and fewer connectors than Raspberry Pi 5, which means that it has less passive heat sinking than the Raspberry Pi 5.

The [BCM2712](#) will reduce the clock rate to try and keep its internal temperature below 85°C. So in high ambient temperatures it is possible that the clock will also be automatically throttled back. If the [BCM2712](#) is unable to lower its internal clocks enough to bring the temperature down, its case temperature will rise above 85°C. It is important that any thermal solution chosen keeps the ambient temperature for the other silicon devices on the CM5 within the operating temperature range.

Operating temperature range: -20°C - +85°C non-condensing. NB Optimal RF wireless performance is between -20°C and +75°C.

3.3. Electrical specification

⊖ WARNING

Stresses above those listed in [Table 2](#) may cause permanent damage to the device. This is a stress rating only; functional operation of the device under these or any other conditions above those listed in the operational sections of this specification is not implied. Exposure to absolute maximum rating conditions for extended periods may affect device reliability.

Table 2. Absolute maximum ratings

Symbol	Parameter	Minimum	Maximum	Unit
V _{IN}	5V Input Voltage	-0.5	6.0	V
V _{GPIO_VREF}	GPIO Voltage	-0.5	3.6	V
V _{gpio}	GPIO Input voltage	-0.5	V _{GPIO_VREF} + 0.5	V

i NOTE

V_{GPIO_VREF} is the GPIO bank voltage, which must be tied to either the 3.3V or the 1.8V rail of the CM5.

Table 3. DC characteristics

Symbol	Parameter	Conditions	Minimum	Typical	Maximum	Unit
V _{IL(gpio)}	Input low voltage	V _{GPIO_VREF} = 3.3V	0	-	0.8	V
V _{IH(gpio)}	Input high voltage	V _{GPIO_VREF} = 3.3V	2.0	-	V _{GPIO_VREF}	V
V _{IL(gpio)}	Input low voltage	V _{GPIO_VREF} = 2.5V	0	-	0.7	V

Symbol	Parameter	Conditions	Minimum	Typical	Maximum	Unit
$V_{IH(gpio)}$	Input high voltage	$V_{GPIO_VREF} = 2.5V$	1.7	-	V_{GPIO_VREF}	V
$V_{IL(gpio)}$	Input low voltage	$V_{GPIO_VREF} = 1.8V$	0	-	$0.35 \cdot V_{GPIO_VREF}$	V
$V_{IH(gpio)}$	Input high voltage	$V_{GPIO_VREF} = 1.8V$	$0.65 \cdot V_{GPIO_VREF}$	-	V_{GPIO_VREF}	V
$I_{IL(gpio)}$	Input leakage current	$V_{GPIO_VREF} = 3.3V$	-	-	3	μA
$I_{IL(gpio)}$	Input leakage current	$V_{GPIO_VREF} = 2.5V$	-	-	5	μA
$I_{IL(gpio)}$	Input leakage current	$V_{GPIO_VREF} = 1.8V$	-	-	7	μA
$V_{OL(gpio)}$	Output low voltage	-	-	-	0.4	V
$V_{OH(gpio)}$	Output high voltage	$V_{GPIO_VREF} = 3.3V$	$V_{GPIO_VREF} - 0.4$	-	-	V
$V_{OH(gpio)}$	Output high voltage	$V_{GPIO_VREF} = 2.5V$	$V_{GPIO_VREF} - 0.5$	-	-	V
$V_{OH(gpio)}$	Output high voltage	$V_{GPIO_VREF} = 1.8V$	$V_{GPIO_VREF} - 0.4$	-	-	V
$I_{OL(gpio)}$	Output current	2mA, $V_{GPIO_VREF} = 3.3V$	6.1	9.6	13.5	mA
$I_{OL(gpio)}$	Output current	4mA, $V_{GPIO_VREF} = 3.3V$	9.2	14.3	20.2	mA
$I_{OL(gpio)}$	Output current	8mA, $V_{GPIO_VREF} = 3.3V$	15.3	23.9	33.7	mA
$I_{OL(gpio)}$	Output current	12mA, $V_{GPIO_VREF} = 3.3V$	18.4	28.7	40.5	mA
$I_{OH(gpio)}$	Output current	2mA, $V_{GPIO_VREF} = 3.3V$	4.5	6.3	8.4	mA
$I_{OH(gpio)}$	Output current	4mA, $V_{GPIO_VREF} = 3.3V$	6.8	9.5	12.6	mA
$I_{OH(gpio)}$	Output current	8mA, $V_{GPIO_VREF} = 3.3V$	11.4	15.8	21	mA
$I_{OH(gpio)}$	Output current	12mA, $V_{GPIO_VREF} = 3.3V$	13.6	19	25.2	mA
$I_{OL(gpio)}$	Output current	2mA, $V_{GPIO_VREF} = 2.5V$	4.7	8	12.2	mA
$I_{OL(gpio)}$	Output current	4mA, $V_{GPIO_VREF} = 2.5V$	7.1	12	18.2	mA
$I_{OL(gpio)}$	Output current	8mA, $V_{GPIO_VREF} = 2.5V$	11.8	20	30.4	mA

Symbol	Parameter	Conditions	Minimum	Typical	Maximum	Unit
$I_{OL(gpio)}$	Output current	12mA, $V_{GPIO_VREF} = 2.5V$	14.1	24	36.4	mA
$I_{OH(gpio)}$	Output current	2mA, $V_{GPIO_VREF} = 2.5V$	3.5	5.1	7	mA
$I_{OH(gpio)}$	Output current	4mA, $V_{GPIO_VREF} = 2.5V$	5.2	7.6	10.5	mA
$I_{OH(gpio)}$	Output current	8mA, $V_{GPIO_VREF} = 2.5V$	8.7	12.7	17.6	mA
$I_{OH(gpio)}$	Output current	12mA, $V_{GPIO_VREF} = 2.5V$	10.4	15.2	21.1	mA
$I_{OL(gpio)}$	Output current	2mA, $V_{GPIO_VREF} = 1.8V$	4.4	8.1	13.6	mA
$I_{OL(gpio)}$	Output current	4mA, $V_{GPIO_VREF} = 1.8V$	8.8	16.3	27.2	mA
$I_{OL(gpio)}$	Output current	8mA, $V_{GPIO_VREF} = 1.8V$	11.8	21.7	36.3	mA
$I_{OL(gpio)}$	Output current	12mA, $V_{GPIO_VREF} = 1.8V$	16.2	29.2	49.9	mA
$I_{OH(gpio)}$	Output current	2mA, $V_{GPIO_VREF} = 1.8V$	3.4	5.3	7.7	mA
$I_{OH(gpio)}$	Output current	4mA, $V_{GPIO_VREF} = 1.8V$	6.9	10.5	15.4	mA
$I_{OH(gpio)}$	Output current	8mA, $V_{GPIO_VREF} = 1.8V$	9.1	14	20.6	mA
$I_{OH(gpio)}$	Output current	12mA, $V_{GPIO_VREF} = 1.8V$	12.6	19.3	28.3	mA
$R_{PU(gpio)}$	Pull-up resistor	$V_{GPIO_VREF} = 3.3V$	37	55	86	k Ω
$R_{PD(gpio)}$	Pull-down resistor	$V_{GPIO_VREF} = 3.3V$	35	55	98	k Ω
$R_{PU(gpio)}$	Pull-up resistor	$V_{GPIO_VREF} = 2.5V$	49	77	123	k Ω
$R_{PD(gpio)}$	Pull-down resistor	$V_{GPIO_VREF} = 2.5V$	49	84	155	k Ω
$R_{PU(gpio)}$	Pull-up resistor	$V_{GPIO_VREF} = 1.8V$	38	64	106	k Ω
$R_{PD(gpio)}$	Pull-down resistor	$V_{GPIO_VREF} = 1.8V$	58	103	189	k Ω

Refer to interface specifications (see [Chapter 2](#)) for electrical details of other interfaces.

Table 4. Power consumption

Symbol	Parameter	Conditions	Minimum	Typical	Maximum	Unit
$I_{shutdown}$	Shutdown current	$PMIC_ENABLE = 0V$	-	1.3	-	mA
$I_{shutdown}$	Shutdown current	$PMIC_ENABLE > 2V$	-	3	-	mA

Symbol	Parameter	Conditions	Minimum	Typical	Maximum	Unit
I_{idle}	Idle current	PMIC_ENABLE > 2V	-	400	-	mA
I_{load}	Operation current	PMIC_ENABLE > 2V	-	900	-	mA
I_{Vbat}	RTC current	Vin = +5V	-	1.7	-	μA
I_{Vbat}	RTC current	Vin = 0V	-	6	-	μA

i NOTE

The figures in [Table 4](#) greatly depend on the end application.

Chapter 4. Pinout

Table 5. Pinout for the Raspberry Pi Compute Module 5

Pin	Signal	Description
1	GND	Ground (0V)
2	GND	Ground (0V)
3	Ethernet_Pair3_P	Ethernet pair 3 positive (connect to transformer or MagJack)
4	Ethernet_Pair1_P	Ethernet pair 1 positive (connect to transformer or MagJack)
5	Ethernet_Pair3_N	Ethernet pair 3 negative (connect to transformer or MagJack)
6	Ethernet_Pair1_N	Ethernet pair 1 negative (connect to transformer or MagJack)
7	GND	Ground (0V)
8	GND	Ground (0V)
9	Ethernet_Pair2_N	Ethernet pair 2 negative (connect to transformer or MagJack)
10	Ethernet_Pair0_N	Ethernet pair 0 negative (connect to transformer or MagJack)
11	Ethernet_Pair2_P	Ethernet pair 2 positive (connect to transformer or MagJack)
12	Ethernet_Pair0_P	Ethernet pair 0 positive (connect to transformer or MagJack)
13	GND	Ground (0V)
14	GND	Ground (0V)
15	Ethernet_nLED3	Active-low Ethernet activity indicator (CM5_3.3V signal): typically a green LED is connected to this pin. $I_{OL} = 8\text{mA}$ @ $V_{OL} < 0.4\text{V}$
16	Fan_Tacho	Fan Tacho Input pin internally pulled up with a 1.8K resistor to CM5_3.3V
17	Ethernet_nLED2	Active-low Ethernet speed indicator ('CM5_3.3V' signal): typically a yellow LED is connected to this pin. A low state indicates the 1Gbit or 100Mbit link: $I_{OL} = 8\text{mA}$ @ $V_{OL} < 0.4\text{V}$
18	Ethernet_SYNC_OUT	IEEE1588 SYNC Output pin (CM5_3.3V signal: $I_{OL} = 8\text{mA}$ @ $V_{OL} < 0.4\text{V}$)
19	Fan_PWM	(Open drain output):
20	EEPROM_nWP	Leave floating NB internally pulled up to CM5_3.3V via 100kΩ ($V_{IL} < 0.8\text{V}$), but can be grounded to prevent writing to the on-board EEPROM which stores the bootcode
21	LED_nACT	Active-low Pi activity LED. 20mA Max, 5V tolerant ($V_{OL} < 0.4\text{V}$). (this is the signal that drives the green LED on the Raspberry Pi 5)
22	GND	Ground (0V)
23	GND	Ground (0V)
24	GPI026	GPIO: typically a 3.3V signal, but can be a 1.8V signal by connecting GPIO_VREF to CM5_1.8V
25	GPI021	GPIO: typically a 3.3V signal, but can be a 1.8V signal by connecting GPIO_VREF to CM5_1.8V
26	GPI019	GPIO: typically a 3.3V signal, but can be a 1.8V signal by connecting GPIO_VREF to CM5_1.8V
27	GPI020	GPIO: typically a 3.3V signal, but can be a 1.8V signal by connecting GPIO_VREF to CM5_1.8V
28	GPI013	GPIO: typically a 3.3V signal, but can be a 1.8V signal by connecting GPIO_VREF to CM5_1.8V
29	GPI016	GPIO: typically a 3.3V signal, but can be a 1.8V signal by connecting GPIO_VREF to CM5_1.8V
30	GPI06	GPIO: typically a 3.3V signal, but can be a 1.8V signal by connecting GPIO_VREF to CM5_1.8V

Pin	Signal	Description
31	<code>GPIO12</code>	GPIO: typically a 3.3V signal, but can be a 1.8V signal by connecting <code>GPIO_VREF</code> to <code>CM5_1.8V</code>
32	<code>GND</code>	Ground (0V)
33	<code>GND</code>	Ground (0V)
34	<code>GPIO5</code>	GPIO: typically a 3.3V signal, but can be a 1.8V signal by connecting <code>GPIO_VREF</code> to <code>CM5_1.8V</code>
35	<code>ID_SC</code>	(BCM2712 GPIO 1) GPIO: typically a 3.3V signal, but can be a 1.8V signal by connecting <code>GPIO_VREF</code> to <code>CM5_1.8V</code>
36	<code>ID_SD</code>	(BCM2712 GPIO 0) GPIO: typically a 3.3V signal, but can be a 1.8V signal by connecting <code>GPIO_VREF</code> to <code>CM5_1.8V</code>
37	<code>GPIO7</code>	GPIO: typically a 3.3V signal, but can be a 1.8V signal by connecting <code>GPIO_VREF</code> to <code>CM5_1.8V</code>
38	<code>GPIO11</code>	GPIO: typically a 3.3V signal, but can be a 1.8V signal by connecting <code>GPIO_VREF</code> to <code>CM5_1.8V</code>
39	<code>GPIO8</code>	GPIO: typically a 3.3V signal, but can be a 1.8V signal by connecting <code>GPIO_VREF</code> to <code>CM5_1.8V</code>
40	<code>GPIO9</code>	GPIO: typically a 3.3V signal, but can be a 1.8V signal by connecting <code>GPIO_VREF</code> to <code>CM5_1.8V</code>
41	<code>GPIO25</code>	GPIO: typically a 3.3V signal, but can be a 1.8V signal by connecting <code>GPIO_VREF</code> to <code>CM5_1.8V</code>
42	<code>GND</code>	Ground (0V)
43	<code>GND</code>	Ground (0V)
44	<code>GPIO10</code>	GPIO: typically a 3.3V signal, but can be a 1.8V signal by connecting <code>GPIO_VREF</code> to <code>CM5_1.8V</code>
45	<code>GPIO24</code>	GPIO: typically a 3.3V signal, but can be a 1.8V signal by connecting <code>GPIO_VREF</code> to <code>CM5_1.8V</code>
46	<code>GPIO22</code>	GPIO: typically a 3.3V signal, but can be a 1.8V signal by connecting <code>GPIO_VREF</code> to <code>CM5_1.8V</code>
47	<code>GPIO23</code>	GPIO: typically a 3.3V signal, but can be a 1.8V signal by connecting <code>GPIO_VREF</code> to <code>CM5_1.8V</code>
48	<code>GPIO27</code>	GPIO: typically a 3.3V signal, but can be a 1.8V signal by connecting <code>GPIO_VREF</code> to <code>CM5_1.8V</code>
49	<code>GPIO18</code>	GPIO: typically a 3.3V signal, but can be a 1.8V signal by connecting <code>GPIO_VREF</code> to <code>CM5_1.8V</code>
50	<code>GPIO17</code>	GPIO: typically a 3.3V signal, but can be a 1.8V signal by connecting <code>GPIO_VREF</code> to <code>CM5_1.8V</code>
51	<code>GPIO15</code>	GPIO: typically a 3.3V signal, but can be a 1.8V signal by connecting <code>GPIO_VREF</code> to <code>CM5_1.8V</code>
52	<code>GND</code>	Ground (0V)
53	<code>GND</code>	Ground (0V)
54	<code>GPIO4</code>	GPIO: typically a 3.3V signal, but can be a 1.8V signal by connecting <code>GPIO_VREF</code> to <code>CM5_1.8V</code>
55	<code>GPIO14</code>	GPIO: typically a 3.3V signal, but can be a 1.8V signal by connecting <code>GPIO_VREF</code> to <code>CM5_1.8V</code>
56	<code>GPIO3</code>	GPIO: typically a 3.3V signal, but can be a 1.8V signal by connecting <code>GPIO_VREF</code> to <code>CM5_1.8V</code> . Internal 1.8kΩ pull-up to <code>GPIO_VREF</code>
57	<code>SD_CLK</code>	SD card clock signal (only available on CM5Lite)
58	<code>GPIO2</code>	GPIO: typically a 3.3V signal, but can be a 1.8V signal by connecting <code>GPIO_VREF</code> to <code>CM5_1.8V</code> . Internal 1.8kΩ pull-up to <code>GPIO_VREF</code>
59	<code>GND</code>	Ground (0V)
60	<code>GND</code>	Ground (0V)
61	<code>SD_DAT3</code>	SD card/eMMC Data3 signal (only available on CM5Lite)
62	<code>SD_CMD</code>	SD card/eMMC Command signal (only available on CM5Lite)
63	<code>SD_DAT0</code>	SD card/eMMC Data0 signal (only available on CM5Lite)

Pin	Signal	Description
64	SD_DAT5	SD card/eMMC Data5 signal (only available on CM5Lite)
65	GND	Ground (0V)
66	GND	Ground (0V)
67	SD_DAT1	SD card/eMMC Data1 signal (only available on CM5Lite)
68	SD_DAT4	SD card/eMMC Data4 signal (only available on CM5Lite)
69	SD_DAT2	SD card/eMMC Data2 signal (only available on CM5Lite)
70	SD_DAT7	SD card/eMMC Data7 signal (only available on CM5Lite)
71	GND	Ground (0V)
72	SD_DAT6	SD card/eMMC Data6 signal (only available on CM5Lite)
73	SD_VDD_OVERRIDE	Connect to CM5_3.3V to force SD card/eMMC interface to 1.8V signalling instead of 3.3V, otherwise leave unconnected. Typically only used if external eMMC is connected.
74	GND	Ground (0V)
75	SD_PWR_ON	Output to power switch for the SD card. The CM5 sets this pin high (3.3V) to signal that power to the SD card should be turned on. Internally Pulled up to CM5_3.3v with a 4.53K (only available on CM5Lite)
76	VBAT	RTC Battery input 2.5V to 3.5V typically 3V
77	+5V (Input)	4.75V-5.25V. Main power input
78	GPIO_VREF	Must be connected to CM5_3.3V (pins 84 and 86) for 3.3V GPIO0-27 or CM5_1.8V (pins 88 and 90) for 1.8V GPIO0-27. This pin cannot be floating or connected to ground.
79	+5V (Input)	4.75V-5.25V. Main power input
80	SCL0	I2C clock pin (GPIO39): typically used for Camera and Display. Internal 1.8kΩ pull-up to CM5_3.3V
81	+5V (Input)	4.75V-5.25V. Main power input
82	SDA0	I2C Data pin (GPIO38): typically used for Camera and Display. Internal 1.8kΩ pull-up to CM5_3.3V
83	+5V (Input)	4.75V-5.25V. Main power input
84	CM5_3.3V (Output)	3.3V ± 5%. Power Output max 300mA per pin for a total of 600mA. This will be powered down during power-off or GLOBAL_EN being set low
85	+5V (Input)	4.75V-5.25V. Main power input
86	CM5_3.3V (Output)	3.3V ± 5%. Power Output max 300mA per pin for a total of 600mA. This will be powered down during power-off or GLOBAL_EN being set low
87	+5V (Input)	4.75V-5.25V. Main power input
88	CM5_1.8V (Output)	1.8V ± 5%. Power Output max 300mA per pin for a total of 600mA. This will be powered down during power-off or GLOBAL_EN being set low
89	WL_nDisable	Can be left floating; if driven low the wireless interface will be disabled. Internally pulled up via 1.8kΩ to CM5_3.3V
90	CM5_1.8V (Output)	1.8V ± 5%. Power Output max 300mA per pin for a total of 600mA. This will be powered down during power-off or GLOBAL_EN being set low
91	BT_nDisable	Can be left floating; if driven low the Bluetooth interface will be disabled. Internally pulled up via 1.8kΩ to CM5_3.3V

Pin	Signal	Description
92	PWR_Button	Pull low to force power off or power on from previous software powered off state. Internally pulled up to +5V via 10kΩ
93	nRPIBOOT	A low on this pin forces booting from an RPI server (e.g. PC or a Raspberry Pi); if not used leave floating. Internally pulled up via 10kΩ to CM5_3.3V
94	CC1	USB PSU PD signal , wire to a USB-C connector to enable 5A @ 5V negotiation.
95	LED_nPWR	(3.3V signal) Active-low output to drive Power On LED. This signal needs to be buffered.
96	CC2	USB PSU PD signal , wire to a USB-C connector to enable 5A @ 5V negotiation.
97	CAM_GPIO0	(3.3V signal) Can be a GPIO (GPIO34) or part of the bus with pin 100
98	GND	Ground (0V)
99	PMIC_Enable	Input. Drive low to power off CM5. Internally pulled up with a 100kΩ to +5V
100	CAM_GPIO1	(3.3V signal) (GPIO35) Internally pulled up with 15K to CM5_3.3V
101	USB_OTG_ID	Input (3.3V signal) USB OTG Pin. Internally pulled up. When grounded the CM5 becomes a USB host but the correct OS driver also needs to be used
102	PCIe_CLK_nREQ	Input (3.3V signal) PCIe clock request pin (low to request PCI clock). Internally pulled up
103	USB_N	USB2.0 D-
104	PCIe_nWAKE	(3.3V signal) PCIe WAKE# signal can be left unconnected if wake up isn't required, internally pulled up.
105	USB_P	USB2.0 D+
106	PCIe_PWR_EN	(3.3V signal) Active high, used to signal that a PCIe device can be powered down when low.
107	GND	Ground (0V)
108	GND	Ground (0V)
109	PCIe_nRST	Output (3.3V signal) PCIe reset active-low
110	PCIe_CLK_P	PCIe clock Out positive (100MHz)
111	VBUS_EN	(3.3V signal) Active high to signal USB3 Ports should be powered
112	PCIe_CLK_N	PCIe clock Out negative (100MHz)
113	GND	Ground (0V)
114	GND	Ground (0V)
115	MIPI0_D0_N	MIPI0 D0 negative
116	PCIe_RX_P	Input PCIe GEN 2 RX positive NB external AC coupling capacitor required
117	MIPI0_D0_P	MIPI0 D0 positive
118	PCIe_RX_N	Input PCIe GEN 2 RX negative NB external AC coupling capacitor required
119	GND	Ground (0V)
120	GND	Ground (0V)
121	MIPI0_D1_N	MIPI0 D1 negative
122	PCIe_TX_P	Output PCIe GEN 2 TX positive NB AC coupling capacitor included on CM5
123	MIPI0_D1_P	MIPI0 D1 positive

Pin	Signal	Description
124	PCIe_TX_N	Output PCIe GEN 2 TX positive NB AC coupling capacitor included on CM5
125	GND	Ground (0V)
126	GND	Ground (0V)
127	MIPI0_C_N	MIPI0 clock negative
128	USB3-0-RX_N	USB3 Port 0 RX Input negative
129	MIPI0_C_P	MIPI0 clock positive
130	USB3-0-RX_P	USB3 Port 0 RX Input positive
131	GND	Ground (0V)
132	GND	Ground (0V)
133	MIPI0_D2_N	MIPI0 D2 negative
134	USB3-0-DP	USB3 port 0 DP
135	MIPI0_D2_P	MIPI0 D2 positive
136	USB3-0-DM	USB3 Port 0 DM
137	GND	Ground (0V)
138	GND	Ground (0V)
139	MIPI0_D3_N	MIPI0 D3 negative
140	USB3-0-TX_N	USB3 Port 0 TX output negative NB AC coupling capacitor included on CM5
141	MIPI0_D3_P	MIPI0 D3 positive
142	USB3-0-TX_P	USB3 Port 0 TX output positive NB AC coupling capacitor included on CM5
143	HDMI1_HOTPLUG	Input HDMI1 hotplug. Internally pulled down with a 100kΩ. 5V tolerant. (It can be connected directly to a HDMI connector)
144	GND	Ground (0V)
145	HDMI1_SDA	Bidirectional HDMI1 SDA. Internally pulled up with a 1.8kΩ. 5V tolerant. (It can be connected directly to a HDMI connector)
146	HDMI1_TX2_P	Output HDMI1 TX2 positive
147	HDMI1_SCL	Bidirectional HDMI1 SCL. Internally pulled up with a 1.8kΩ. 5V tolerant. (It can be connected directly to a HDMI connector)
148	HDMI1_TX2_N	Output HDMI1 TX2 negative
149	HDMI1_CEC	Input HDMI1 CEC. Internally pulled up with a 27kΩ. 5V tolerant. (It can be connected directly to a HDMI connector)
150	GND	Ground (0V)
151	HDMI0_CEC	Input HDMI0 CEC. Internally pulled up with a 27kΩ. 5V tolerant (It can be connected directly to a HDMI connector)
152	HDMI1_TX1_P	Output HDMI1 TX1 positive
153	HDMI0_HOTPLUG	Input HDMI0 hotplug. Internally pulled down 100kΩ. 5V tolerant. (It can be connected directly to a HDMI connector)
154	HDMI1_TX1_N	Output HDMI1 TX1 negative
155	GND	Ground (0V)

Pin	Signal	Description
156	GND	Ground (0V)
157	USB3-1-RX_N	USB3 Port 1 RX Input negative
158	HDMI1_TX0_P	Output HDMI1 TX0 positive
159	USB3-1-RX_P	USB3 Port 1 RX Input positive
160	HDMI1_TX0_N	Output HDMI1 TX0 negative
161	GND	Ground (0V)
162	GND	Ground (0V)
163	USB3-1-DP	USB3 port 1 DP
164	HDMI1_CLK_P	Output HDMI1 clock positive
165	USB3-1-DM	USB3 Port 1 DM
166	HDMI1_CLK_N	Output HDMI1 clock negative
167	GND	Ground (0V)
168	GND	Ground (0V)
169	USB3-1-TX_N	USB3 Port 1 TX output negative NB AC coupling capacitor included on CM5
170	HDMI0_TX2_P	Output HDMI0 TX2 positive
171	USB3-1-TX_P	USB3 Port 1 TX output positive NB AC coupling capacitor included on CM5
172	HDMI0_TX2_N	Output HDMI0 TX2 negative
173	GND	Ground (0V)
174	GND	Ground (0V)
175	MIPI1_D0_N	MIPI1 D0 negative
176	HDMI0_TX1_P	Output HDMI0 TX1 positive
177	MIPI1_D0_P	MIPI1 D0 positive
178	HDMI0_TX1_N	Output HDMI0 TX1 negative
179	GND	Ground (0V)
180	GND	Ground (0V)
181	MIPI1_D1_N	MIPI1 D1 negative
182	HDMI0_TX0_P	Output HDMI0 TX0 positive
183	MIPI1_D1_P	MIPI1 D1 positive
184	HDMI0_TX0_N	Output HDMI0 TX0 negative
185	GND	Ground (0V)
186	GND	Ground (0V)
187	MIPI1_C_N	MIPI1 clock negative
188	HDMI0_CLK_P	Output HDMI0 clock positive
189	MIPI1_C_P	MIPI1 clock positive
190	HDMI0_CLK_N	Output HDMI0 clock negative
191	GND	Ground (0V)

Pin	Signal	Description
192	GND	Ground (0V)
193	MIPI1_D2_N	MIPI1 D2 negative
194	MIPI1_D3_N	MIPI1 D3 negative
195	MIPI1_D2_P	MIPI1 D2 positive
196	MIPI1_D3_P	MIPI1 D3 positive
197	GND	Ground (0V)
198	GND	Ground (0V)
199	HDMI0_SDA	Bidirectional HDMI0 SDA. Internally pulled up with a 1.8kΩ. 5V tolerant. (It can be connected directly to a HDMI connector; a small amount of ESD protection is provided on the CM5 by an on-board HDMI05-CL02F3)
200	HDMI0_SCL	Bidirectional HDMI0 SCL. Internally pulled up with a 1.8kΩ. 5V tolerant. (It can be connected directly to a HDMI connector; a small amount of ESD protection is provided on the CM5 by an on-board HDMI05-CL02F3)

All ground pins should be connected. If none of the signals on the second connector (pins 101 to 200) are used, then you may omit the connector to reduce costs, but mechanical stability needs to be considered.

The voltage on GPIO pins 0-27 must not exceed `CM5_3.3V` if 3.3V signalling is used or `CM5_1.8V` if 1.8V signalling is used. These pins are the same as on the 40-pin connector on the Raspberry Pi 5.

If the `CM5_1.8V` rail is used to power other devices other than the `GPIO_VREF` then you should ensure that in case of surprise power removal (e.g. the +5V pin goes below +4.5V) from the CM5, the load on the `CM5_1.8V` must go to zero.

Similarly if the `CM5_3.3V` rail is used to power other devices other than the `GPIO_VREF`, then you should ensure that in the case of surprise power removal the `CM5_3.3V` rail never falls below the `CM5_1.8V` rail. This is the typical case, but you should check this in your design. In the case where it does fall below the `CM5_1.8V` rail, then extra circuitry is required to disconnect the `CM5_3.3V` load.

No reverse voltage must be applied to any pin, or power-up may be prevented; i.e. during power-down/off no pin may have external voltage applied, otherwise this may prevent a subsequent power-up.

4.1. Differential pairs

It is recommended that P/N signals within a pair are matched to better than 0.15mm. Often, matching between pairs is not so critical: e.g. HDMI pair-to-pair matching should be better than 25mm, so on a typical board no extra matching is required.

4.1.1. 100Ω differential pair signal lengths

On the CM5 all differential pairs are matched to better than 0.05mm (P/N signals).

i NOTE

It is recommended that pairs are also matched on the interface board.

On the CM5, pair-to-pairs are not always matched, as many interfaces do not require very accurate matching between pairs. [Table 6](#) documents the CM5 track-length difference within each group. (A non-zero value represents how much longer in mm that track is, when compared to the signal with zero length difference.)

Table 6. 100Q
differential pair signal
lengths

Signal	Length
MIPI0_C_N	0.78
MIPI0_C_P	0.78
MIPI0_D0_N	0.01
MIPI0_D0_P	0.02
MIPI0_D1_N	0.4
MIPI0_D1_P	0.4
MIPI0_D2_N	0.04
MIPI0_D2_P	0.03
MIPI0_D3_N	0.01
MIPI0_D3_P	0
MIPI1_C_N	1.28
MIPI1_C_P	1.27
MIPI1_D0_N	0
MIPI1_D0_P	0
MIPI1_D1_N	1.06
MIPI1_D1_P	1.05
MIPI1_D2_N	0.83
MIPI1_D2_P	0.84
MIPI1_D3_N	3.79
MIPI1_D3_P	3.79
HDMI0_CLK_N	0.91
HDMI0_CLK_P	0.91
HDMI0_TX0_N	0.18
HDMI0_TX0_P	0.18
HDMI0_TX1_N	0
HDMI0_TX1_P	0
HDMI0_TX2_N	0.25
HDMI0_TX2_P	0.25
HDMI1_CLK_N	2.99
HDMI1_CLK_P	2.99
HDMI1_TX0_N	4.76
HDMI1_TX0_P	4.75
HDMI1_TX1_N	5.18
HDMI1_TX1_P	5.18

HDMI1_TX2_N	0
HDMI1_TX2_P	0
Ethernet_Pair0_P	2.92
Ethernet_Pair0_N	2.93
Ethernet_Pair1_P	0
Ethernet_Pair1_N	0
Ethernet_Pair2_P	0.59
Ethernet_Pair2_N	0.60
Ethernet_Pair3_P	0.38
Ethernet_Pair3_N	0.38

4.1.2. 90Ω differential pair signal lengths

On the CM5 all 90Ω differential pairs (including USB pairs) are matched to better than 0.01mm (P/N signals). USB 3 pairs don't require any pair to pair matching within a port group.

i NOTE

It is recommended that pairs are also matched on the interface board.

Pair-to-pairs aren't always matched as many interfaces don't require very accurate matching between pairs. [Table 7](#) documents the CM5 track-length difference within each group. (A non-zero value represents how much longer in mm that track is, when compared to the signal with zero length difference.)

Table 7. 90Ω differential pair signal lengths

Signal	Length
PCIe_CLK_P	0.00
PCIe_CLK_N	0.01
PCIe_TX_P	3.71
PCIe_TX_N	3.72
PCIe_RX_P	0.84
PCIe_RX_N	0.84

Chapter 5. Power

5.1. Power-up sequencing

The CM5 requires a single +5V supply, and can supply up to 600mA at +3.3V and +1.8V to peripherals.

All pins should not have any power applied to them before the +5V rail is applied.

If the on board boot EEPROM is to be write-protected, then the `EEPROM_nWP` should be low before power-up.

If the CM5 is to be booted using USB then `RPI_nBOOT` needs to be low within 2ms of +5V rising.

+5V should rise monotonically to 4.75V and stay above 4.75V for the entire operation of the CM5.

The power-up sequence will start when both +5V rail is above 4.75V and `PMIC_EN` rises. The order of events is as follows

1. +5V rises
2. `PMIC_ENABLE` rises
3. `CM5_+3.3V` rises
4. `CM5_+1.8V` rises at least 1ms after `CM5_+3.3V`

5.2. Power-down sequencing

The operating system should be shut down before power is removed to ensure file system consistency. If this can't be achieved, then a filesystem like `btrfs`, `f2fs` or `overlays` (use `raspi-config` to enable this) should be considered.

Once the operating system has shut down, the +5V rail can be removed or the `PMIC_EN` pin can be taken low to put the CM5 into the lowest power mode.

During the shutdown sequence `CM5_+1.8V` will be discharged before the `CM5_+3.3V` rail.

5.3. Power consumption

The exact power consumption of the CM5 will greatly depend on the tasks being run on the CM5. The lowest shutdown power consumption mode is with the `PMIC_EN` driven low, typically is 1.3µA. With `PMIC_EN` high but software shut down, the typical consumption is 3mA. Idle power consumption is typically 400mA, but this varies considerably depending on the operating system. Operating power consumption is typically around 900mA; again, this greatly depends on the operating system and the tasks being executed.

5.4. Regulator outputs

To make it easier to interface to the CM5 the on-board regulators (`CM5_+3.3V` and `CM5_+1.8V`) can each supply 600mA to devices connected to the CM5. The loads on these outputs isn't taken into account in the power consumption figures.

Appendix A: Troubleshooting

The CM5 has a number of stages of power-up before the CPU starts. If there is an error at any of the stages, power-up will be halted.

Hardware checklist

1. Is the +5V supply good? Check this by pulling `PMIC_EN` low and apply an external 2A load to the +5V supply. Does it stay > +4.75V including noise? Ideally, it should remain > +4.9V including any noise.
2. Remove external 2A load, but keep `PMIC_EN` pulled low.
3. Check the CM5 +3.3V rail is < 200mV. If this is not the case there is an external power path back-feeding the CM5, either directly or indirectly. This could also occur via the digital pins, e.g Ethernet.
4. Still with `PMIC_EN` pulled low check the CM5 +1.8V rail is < 200mV. Again if the +1.8V rail is above 200mV then there is an external path back-feeding the 1.8V rail. If nothing is connected to these pins, you can ignore this check.
5. Remove the pull-down on `PMIC_EN`.
6. Check `PMIC_EN` now goes high (it is internally pulled up on the CM5).
7. Check the +3.3V supply rises to > +3.15V. If it does not, this suggests there is too much load on the +3.3V rail.
8. Check the +1.8V rail gets to > +1.71V. If it does not, this suggests there is too much load on the +1.8V rail.
9. Check `ACT_LED` starts to oscillate to indicate booting; check it isn't flashing an error code.

Bootloader

1. Connect a HDMI cable to see if the HDMI diagnostics screen appears.
2. Connect a USB serial cable to GPIO pins 14 and 15. For more information, see [Configuring UARTs](#).
3. Short the `nRPIBOOT` pin to ground to force USB boot mode. The CM5IO board has a jumper for `nRPIBOOT` This can be used to enable different boot modes (e.g. network) and enable UART logging. For more information, see [Flashing the Compute Module eMMC](#).

rpi-eeeprom-update

CM5 will not run `recovery.bin` from the eMMC (or SD card on CM5Lite). Therefore, the only way to update the bootloader EEPROM is via `usbboot` or self-update.

EEPROM write-protect

The on-board EEPROM can be write-protected by shorting `EEPROM_nWP` to ground. The CM5IO board has a jumper for `EEPROM_nWP`.

For more information, see [Raspberry Pi boot EEPROM](#).

Firmware

Ensure you have the latest version of the firmware, as newer versions contain improvements to the system.

Kernel

Ensure you have the latest version of the kernel, as newer versions often contain security fixes and improvements.

Appendix B: Test Points

Test Points

CM5 contains a number of test points on the board. These can be used to power and program a CM5 without using the main 100pin connectors. Most of the signals replicate pins on the 100 pin connectors.

Table of test point coordinates and mounting hole locations. The coordinates are looking through the CM5.

Table 8. Test point table for the Raspberry Pi Compute Module 5

Reference	X	Y	NAME
MH4	51.5	36.5	Mounting Hole
MH3	3.5	36.5	Mounting Hole
MH2	51.5	3.5	Mounting Hole
MH1	3.5	3.5	Mounting Hole
TP1	14.34	17.54	+5V
TP2	8.8	1.3	RUN
TP3	51.2	32.6	GND
TP4	4.8	13	reserved
TP7	24.2	7.5	GND
TP8	1.65	15.05	GND
TP9	1.5	10.5	reserved
TP10	48.4	15.1	reserved
TP13	42.6	7.3	GND
TP15	14.7	6.6	reserved
TP16	9.3	34.9	nRPIBOOT
TP17	37.4	8.1	reserved
TP18	23.4	23.55	reserved
TP21	24.5125	14.025	nRESET_OUT
TP22	13.0875	11.225	reserved
TP26	17.7	20.2	GND
TP27	43.6	22.3	reserved
TP28	15.4	16	reserved
TP29	23.65	21.55	reserved
TP30	37.2	34.9	reserved
TP31	9.1	3.2	reserved
TP32	1.5	13	reserved
TP33	47	36	CM5_3V3
TP34	50.5	15.5	CM5_1V8

Reference	X	Y	NAME
TP35	11	37.8	DEBUG_UART_TX
TP36	8.5	37.1	DEBUG_UART_RX
TP39	22.1	6.1	reserved
TP40	6.7	15.2	reserved
TP41	8.7	15.3	reserved
TP42	11.4	34.9	PWR_BUT
TP44	51.7	30.2	reserved
TP45	53.1	28.7	reserved
TP46	7	34.7	GND
TP48	21.6	15.4	SOC_TRST_N
TP49	21.6	13.3	SOC_TDI
TP50	20.4	17.2	SOC_TDO
TP51	20.3	8.8	SOC_TMS
TP52	19.9	11.9	SOC_TCK
TP57	53.2	32	reserved
TP60	48	38.7	GND
TP61	6.575	1.225	GND
TP62	22.2	31.6	GND
TP63	8.7	18.2	5v_Sense
TP64	47.3	5.4	reserved
TP65	28.2	7.5	USBC_D_N
TP66	26.1	7.5	USBC_D_P
TP67	7	38.6	LED_nPWR
TP68	13	37.5	LED_nACT
TP69	38.8	25.9	ETH0_P
TP70	39.6	24.2	ETH0_N
TP71	43.8	14.1	ETH1_N
TP72	45.6	13.1	ETH1_P
TP73	42.4	31.7	ETH2_P
TP74	42.6	33.7	ETH2_N
TP75	41.6	37.8	ETH3_P
TP76	42.9	36.1	ETH3_N
TP77	45	37	GPIO_VREF
TP78	14.37	19.52	+5V

Powering Vin

Both Vin test points (TP1 and TP78) should be used with a +5V supply. Ground must be connected to at least TP26, TP61, and TP8. Other ground pins should be also used if possible.

Debug UART

TP35 and TP36 are a TX and RX of the debug UART. TP46 should be used as the ground. It is very useful to have access to these pins during programming and initial boot.

RPI Boot

TP65 and TP66 are the USB pins. The TP7 GND pin must be used. TP16 nRPI_BOOT should also be grounded to force RPI boot mode.

Ethernet Boot

TP69-TP70 should be connected to an external MagJack.

Appendix C: Differences between CM4 and CM5

This section describes the differences between Raspberry Pi Compute Module 5 (CM5) and the previous Raspberry Pi Compute Module 4 (CM4).

Pinout changes

The connectors have changed brand and have been tested to higher currents to support CM5.

CAM1 signals become dual-purpose and can be used for either a CSI camera or a DSI display.

DSI1 signals become dual-purpose and can be used for either a CSI camera or a DSI display.

The CM4 has extra ESD protection on the HDMI, SDA, SCL, HPD and CEC signals. This is removed from the Raspberry Pi Compute Module 5.

The port labelled **CAM0** on CM4 now is a USB 3.0 Port. The port labelled **DSI0** now is a USB 3.0 port. The original CM4 **VDAC_COMP** pin is now a VBUS enable pin for the two USB 3 ports and is active high.

The 2 ADC channels on CM4 have now become the PD CC signals.

Pin	CM4	CM5	Comment
16	SYNC_IN	Fan_tacho	Fan tacho input
19	Ethernet nLED1	Fan_PWM	Fan PWM output
76	Reserved	VBAT	RTC battery. Note, there will be a constant load of a few uA even if the CM5 is powered.
92	RUN_PG	PWR_Button	Replicates the power button on Raspberry Pi 5. A short press signals that the device should wake up or shut down. A long press forces shutdown.
93	nRPIBOOT	nRPIBOOT	
94	AnalogIP1	CC1	This pin can connect to the CC1 line of a USB-C connector to enable the PMIC to negotiate 5A.
96	AnalogIP0	CC2	This pin can connect to the CC2 line of a USB-C connector to enable the PMIC to negotiate 5A.
99	Global_EN	PMIC_ENABLE	No external change.

Pin	CM4	CM5	Comment
100	nEXTRST	CAM_GPIO1	Pulled up on Raspberry Pi Compute Module 5, but is driven low during boot to emulate a nRESET signal
104	Reserved	PCIE_DET_nWAKE	PCIE nWAKE. Pull-up to CM5_3v3 with an 8.2K resistor.
106	Reserved	PCIE_PWR_EN	Signals if the PCIe device can be powered up or down. Active high.
111	VDAC_COMP	VBUS_EN	Output to signal USB VBUS should be enabled.
128	CAM0_D0_N	USB3-0-RX_N	May be P/N swapped.
130	CAM0_D0_P	USB3-0-RX_P	May be P/N swapped.
134	CAM0_D1_N	USB3-0-DP	USB 2 signal.
136	CAM0_D1_P	USB3-0-DM	USB 2 signal.
140	CAM0_C_N	USB3-0-TX_N	May be P/N swapped.
142	CAM0_C_P	USB3-0-TX_P	May be P/N swapped.
157	DSI0_D0_N	USB3-1-RX_N	May be P/N swapped.
159	DSI0_D0_P	USB3-1-RX_P	May be P/N swapped.
163	DSI0_D1_N	USB3-1-DP	USB 2 signal.
165	DSI0_D1_P	USB3-1-DM	USB 2 signal.
169	DSI0_C_N	USB3-1-TX_N	May be P/N swapped.
171	DSI0_C_P	USB3-1-TX_P	May be P/N swapped.

In addition to the above, the PCIe CLK signals are no longer capacitively coupled.

The PCB is 0.04mm thicker, but the main processor is thinner

Track lengths

HDMI0 track lengths have changed. Each P/N pair remains matched, but the skew between pairs is now <1mm. For existing motherboards, this is unlikely to make a difference as the skew between pairs can be in the order of 25mm.

HDMI1 track lengths have also changed. Each P/N pair remains matched, but the skew between pairs is now <5mm. For existing motherboards, this is unlikely to make a difference as the skew between pairs can be in the order of 25mm.

Ethernet track lengths have changed. Each P/N pair remains matched, but the skew between pairs is now <4mm. For existing motherboards, this is unlikely to make a difference as the skew between pairs can be in the order of 12mm.

Power budget

As CM5 is significantly more powerful than CM4, it consumes more power. Power supply designs should budget for 5V up to 2.5A. If this creates an issue with an existing motherboard design, reduce the CPU clock rate to reduce the peak

power consumption.

Appendix D: Availability

Support

For documentation please see the [Compute Module Hardware documentation](#) section of the [raspberrypi.com](https://www.raspberrypi.com). Support questions can be posted to the [Raspberry Pi forum](#).

Order codes

Table 9. Part number options

Model	Wireless	RAM LPDDR4x	eMMC Storage
CM5	0 = No	01 = 1GB	000 = 0GB (Lite)
	1 = Yes	02 = 2GB	008 = 8GB
		04 = 4GB	016 = 16GB
		08 = 8GB	032 = 32GB
			064 = 64GB
			128 = 128GB
Example Part Number			
CM5	1	02	032

Table 10. Ordering options

Wireless	RAM LPDDR4x	Storage eMMC	RPL #	Part Number	Order Multiple	RRP
-	2GB	Lite	SC1156	CM5002000	1+ / Bulk	
-	2GB	16GB	SC1158	CM5002016	1+ / Bulk	
-	2GB	32GB	SC1159	CM5002032	1+ / Bulk	
Yes	2GB	Lite	SC1586	CM5102000	1+ / Bulk	
Yes	2GB	16GB	sC1588	CM5102016	1+ / Bulk	
Yes	2GB	32GB	SC1589	CM5102032	1+ / Bulk	
-	4GB	Lite	SC1562	CM5004000	1+ / Bulk	
-	4GB	16GB	SC1564	CM5004016	1+ / Bulk	
-	4GB	32GB	SC1565	CM5004032	1+ / Bulk	
Yes	4GB	Lite	SC1592	CM5104000	1+ / Bulk	
Yes	4GB	16GB	SC1594	CM5104016	1+ / Bulk	
Yes	4GB	32GB	SC1595	CM5104032	1+ / Bulk	
-	8GB	Lite	SC1568	CM5008000	1+ / Bulk	
-	8GB	16GB	SC1570	CM5008016	1+ / Bulk	
-	8GB	32GB	SC1571	CM5008032	1+ / Bulk	
Yes	8GB	Lite	SC1598	CM5108000	1+ / Bulk	

Wireless	RAM LPDDR4x	Storage eMMC	RPL #	Part Number	Order Multiple	RRP
Yes	8GB	16GB	SC1600	CM5108016	1+ / Bulk	
Yes	8GB	32GB	SC1601	CM5108032	1+ / Bulk	

i NOTE

Other options are available as a custom order

Packaging

Small quantities are supplied in individual cardboard boxes. These have an internal ESD coating so that a separate ESD bag isn't required. This packaging is recyclable and reduces waste.

Appendix E: Mean Time Between Failure (MTBF)

Table 11. Mean time between failure for Raspberry Pi Compute Module 5

Model	Mean Time Between Failure Ground Benign (Hours)	Mean Time Between Failure Ground Mobile (Hours)
CM5	143 000	16 000
CM5Lite	168 000	16 000

Ground, benign

Applies to non-mobile, temperature and humidity controlled environments readily accessible to maintenance; includes laboratory instruments and test equipment, medical electronic equipment, business and scientific computer complexes.

Ground, mobile

Assumes levels of operational stress well above normal domestic or light industrial use, without temperature, humidity or vibration control: applies to equipment installed on wheeled or tracked vehicles and equipment manually transported; includes mobile and handheld communications equipment.

Appendix H: Documentation Release History

27 November 2024

- Initial release.



Raspberry Pi is a trademark of Raspberry Pi Ltd

X-ON Electronics

Largest Supplier of Electrical and Electronic Components

Click to view similar products for [System-On-Modules - SOM category](#):

Click to view products by [Raspberry Pi manufacturer](#):

Other Similar products are found below :

[PICOIMX6U10R1GBNI4GBW](#) [MC27561-TIGER](#) [MC27561-FOX](#) [BD63725BEFV-EVK-002](#) [BKCM11EBV58W](#) [BKCM11EBV716W](#)
[CM4102008](#) [COMX_P4080](#) [A20-SOM-EVB](#) [SIP-005AYS001](#) [A13-SOM-256](#) [RK3188-SOM](#) [RK3188-SOM-4GB](#) [SIMBA-PRO-M](#) [ROM-3420CD-MDA1E](#) [SOM-5890FG-U1B1E](#) [CC-MX-JN58-Z1](#) [CC-WMX-JN58-NE](#) [RXCA10S027PF34-SOM00L](#) [100-1225-1](#) [OSD3358-512M-BSM](#) [A20-SOM-N8GB](#) [PER-TAICX-A10-001](#) [PER-TAIX2-A10-2280](#) [EDL-mPCIe-MA2485](#) [SOM-6872VC-U9A1](#) [SOM-6883C7-S8A1](#)
[SOM-6883C3-U2A1](#) [SOM-6883CR-S8A1](#) [SOM-7583C7-S8A1](#) [SOM-7583CR-S8A1](#) [Nit6Q_SOM_v2](#) [G650-04474-01](#) [5728-PJ-4AA-RC](#)
[5749-PM-4AA-RI](#) [5CSE-L2-3Y8-RC](#) [5CSX-H6-4YA-RI](#) [L138-FX-325-RC](#) [20-101-0383](#) [20-101-0435](#) [20-101-0434](#) [20-101-0672](#) [20-101-1093](#) [20-101-1112](#) [CC-WMX-FS7D-NN](#) [CC-WMX-KK8D-TN](#) [CC-MX-L76C-Z1](#) [EA-OEM-009](#) [G120E-SM-532](#) [G400D-SM-400](#)