



RAYSTAR

曜凌光電股份有限公司

住址: 42878 台中市大雅区科雅路 25 號 5F WEB: <http://www.Raystar-Optronics.com>
5F., No.25, Keya Rd., Daya Dist., Taichung E-mail: sales@raystar-optronics.com
City 428, Taiwan Tel:886-4-2565-0761 Fax : 886-4-2565-0760

RFC350M-EIW-DRS

SPECIFICATION

CUSTOMER:

APPROVED BY	
PCB VERSION	
DATE	

FOR CUSTOMER USE ONLY

SALES BY	APPROVED BY	CHECKED BY	PREPARED BY

Release DATE:

TFT Display Inspection Specification: <https://www.raystar-optronics.com/download/products.htm>

Precaution in use of TFT module: <https://www.raystar-optronics.com/download/declaration.htm>

Revision History

VERSION	DATE	REVISED PAGE NO.	Note
0	2014/10/13		First issue
A	2015/05/27		Add SPI Timing Characteristics Modify Instructions Table. Add Resistance Touch Panel General Specifications. Modify Reliability. Modify Interface: RS232 19200 Baud rate/SPI & VDD=>VBUS.
B	2016/01/21		Modify Static electricity test
C	2016/05/19		Modify RS232->Uart .
D	2016/08/11		Modify Vibration test
E	2016/10/17		Modify Summary
F	2017/03/30		Add Aspect Ratio
G	2017/07/19		Modify FPC
H	2019/11/18		Add Operating mode Modify LED voltage
I	2020/04/15		Add Relationship and Flash Memory Size and Uniformity

Contents

1. Module Classification Information
2. Summary
3. General Specification
4. Interface
5. Contour Drawing
6. Absolute Maximum Ratings
7. Electrical Characteristics
8. DC Characteristics
9. AC Characteristics
10. Waveform
11. Optical Characteristics
12. Reliability
13. Touch Panel Information
14. Initial Code For Reference
15. Other

2.Summary

TFT 3.5" is a TN transmissive type color active matrix TFT liquid crystal display that use amorphous silicon TFT as switching devices. This module is composed of a TFT_LCD module, It is usually designed for industrial application and this module follows RoHs,

RAYSTAR OPTRONICS

3.General Specifications

- Size: 3.5 inch
- Dot Matrix: 320 x RGBx240(TFT) dots
- Module dimension: 100(W) x 66.44(H) x 8.9(D) mm
- Active area: 70.08 x 52.56 mm
- Dot pitch: 0.219 x 0.073 mm
- LCD type: TFT, Normally White, Transmissive
- View Direction: 12 o'clock
- Gray Scale Inversion Direction: 6 o'clock
- Aspect Ratio: 4:3
- Backlight Type: LED, Normally White
- Interface: Uart 19200 Baud rate/SPI
- With /Without TP: With RTP
- Surface: Anti-Glare
- Operating mode: Slave mode
- Flash Memory Size: 32M bits

*Color tone slight changed by temperature and driving voltage

4.Interface

CON 2			
Pin	Symbol	I/O	Function
1	GND	Power Supply	Power Ground
2	TX	O	Uart Transmit pin
3	RX	I	Uart Receive pin
4	VBUS	Power Supply	Power supply : 5V
5	D+	I/O	USB Data +
6	D-	I/O	USB Data -
7	GND	Power Supply	Power Ground
8	/RST	I	Reset (active Low)
9	GND	Power Supply	Power Ground
10	PWM	O	Pulse width modulation
11	GND	Power Supply	Power Ground
12	VBUS	Power Supply	Power supply : 5V

CON 3			
Pin	Symbol	I/O	Function
1	GND	Power Supply	Power Ground
2	SW1	I	Switch (active low)
3	SW2	I	Switch (active low)
4	SW3	I	Switch (active low)
5	SW4	I	Switch (active low)
6	GND	Power Supply	Power Ground
7	SDI	O	Master Input Slave Output (MISO)
8	SDO	I	Master Output Slave Input (MOSI)
9	SCK	I	Serial Clock
10	SCS	I	Serial Chip selection
11	SPI_INT	O	Serial Interrupt
12	VBUS	Power Supply	Power supply : 5V

5. Contour Drawing

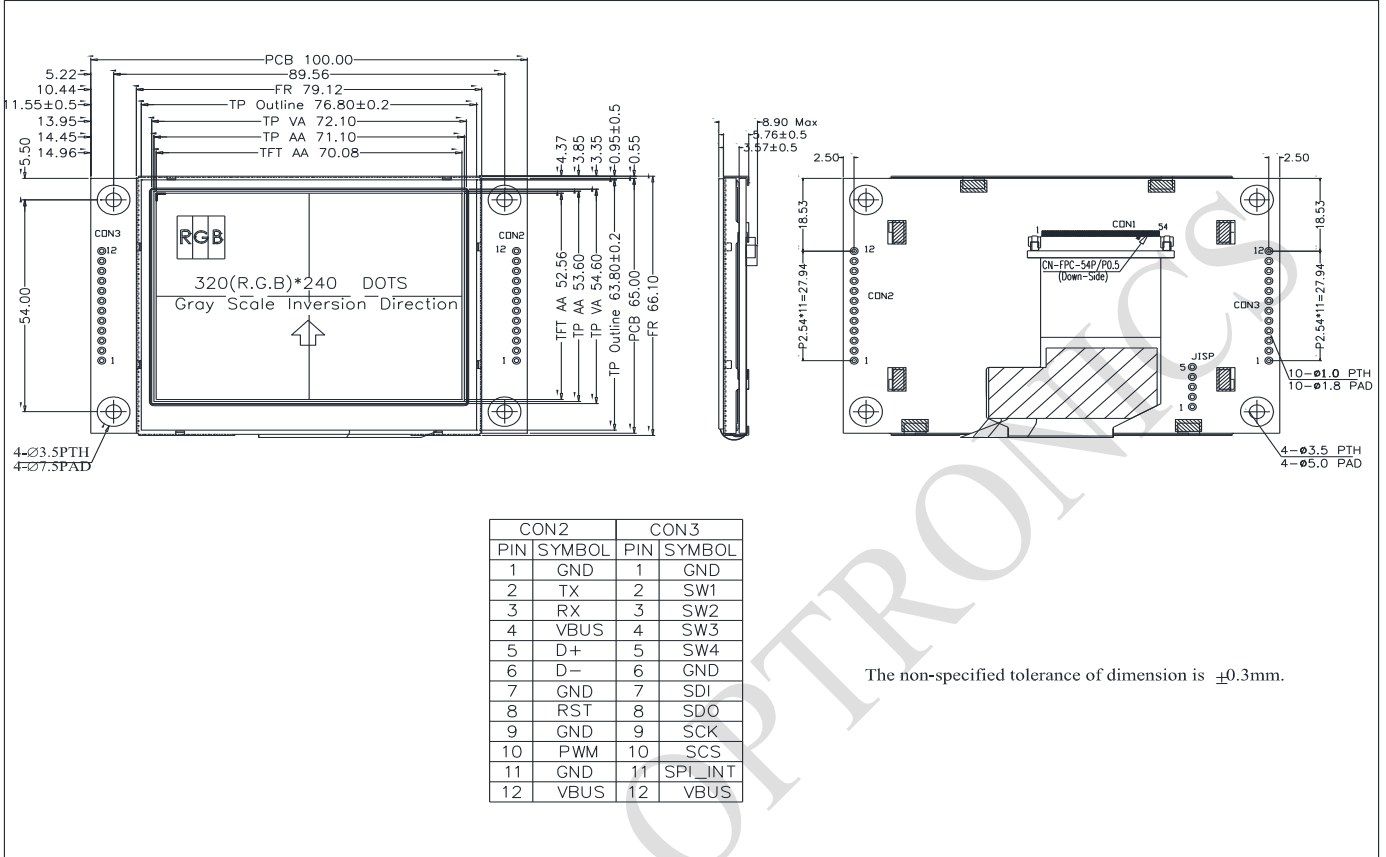

6. Absolute Maximum Ratings

Item	Symbol	Min	Typ	Max	Unit
Operating Temperature	TOP	-20	—	+70	°C
Storage Temperature	TST	-30	—	+80	°C

Note: Device is subject to be damaged permanently if stresses beyond those absolute maximum ratings listed above

- Temp. $\leq 60^{\circ}\text{C}$, 90% RH MAX. Temp. $> 60^{\circ}\text{C}$, Absolute humidity shall be less than 90% RH at 60°C

RAYSTAR OPTRONICS

7. Electrical Characteristics

7.1. Operating conditions:

Item	Symbol	Condition	Min	Typ	Max	Unit	Remark
Supply Voltage For LCM	VBUS	—	4.5	5	5.5	V	—
Supply Current For LCM	IBUS	—	—	160	240	mA	Note1
Power Consumption	—	VBUS=5V	—	800	1320	mW	VBUS=5V Note 2

Note 1 : This value is test for VBUS=5V , Ta=25 °C only

Note 2 : Power consumption is include Backlight driver system

7.2. LED driving conditions (LED Driver system build in)

Parameter	Symbol	Min.	Typ.	Max.	Unit	Remark
LED current		-	20	-	mA	
Power Consumption		336	384	408	mW	
LED voltage	LED+	16.8	19.2	20.4	V	Note 1
LED Life Time		-	50,000	-	Hr	Note 2,3,4

Note 1 : There are 1 Groups LED

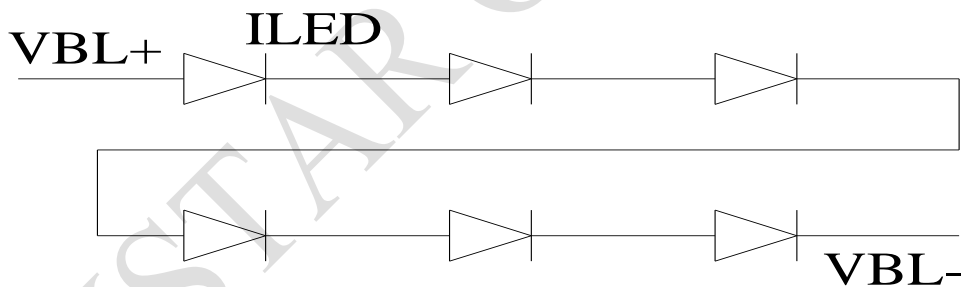

Note 2 : Ta = 25 °C

Note 3 : Brightness to be decreased to 50% of the initial value

Note 4 : The single LED lamp case

8.DC CHARATERISTICS

Parameter	Symbol	Rating			Unit	Condition
		Min	Typ	Max		
Low level input voltage	V_{IL}	0	-	$0.3V_{BUS}$	V	
High level input voltage	V_{IH}	$0.7V_{BUS}$	-	V_{BUS}	V	

RAYSTAR OPTRONICS

9.SPI Timing Characteristics

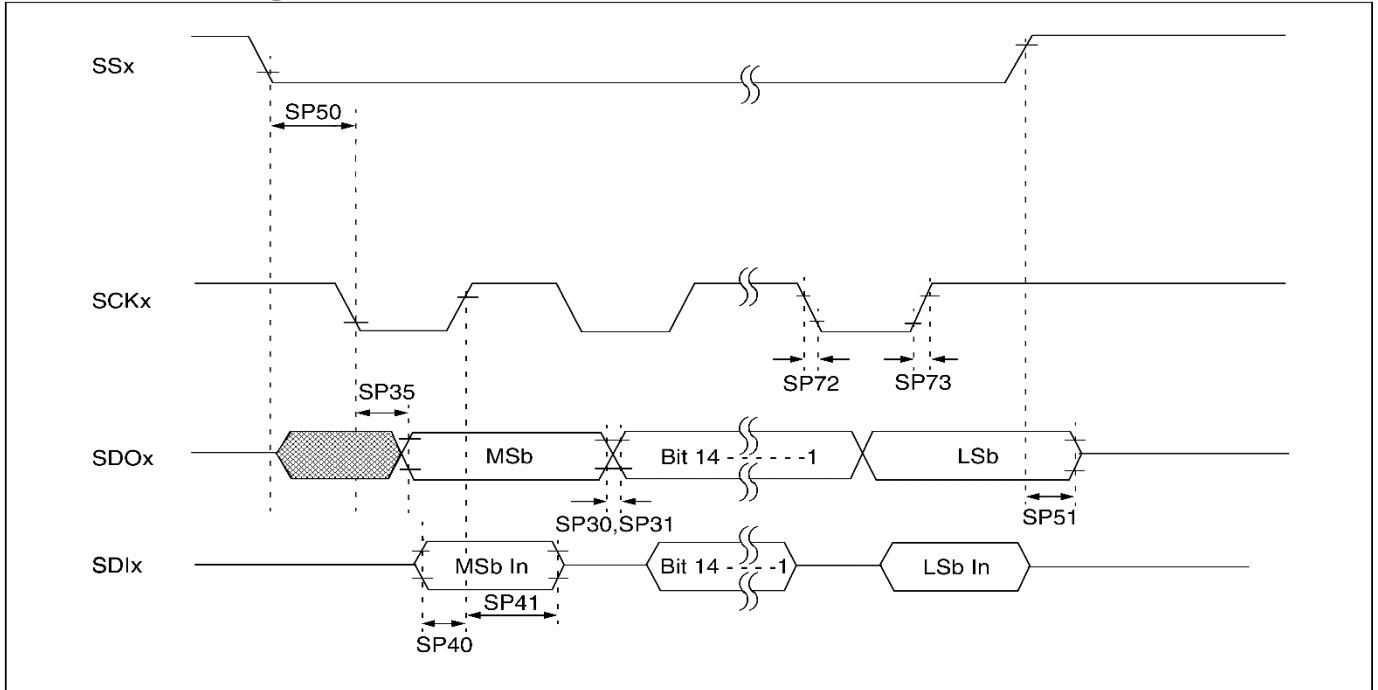

AC CHARACTERISTICS			Standard Operating Conditions: 2.0V to 3.6V (unless otherwise stated) Operating temperature $-40^{\circ}\text{C} \leq T_A \leq +85^{\circ}\text{C}$ for Industrial				
Param No.	Symbol	Characteristic	Min	Typ ⁽¹⁾	Max	Units	Conditions
SP70	TscL	SCKx Input Low Time	250	—	—	ns	
SP71	TscH	SCKx Input High Time	250	—	—	ns	
SP72	TscF	SCKx Input Fall Time ⁽²⁾	—	10	25	ns	
SP73	TscR	SCKx Input Rise Time ⁽²⁾	—	10	25	ns	
SP30	TdoF	SDOx Data Output Fall Time ⁽²⁾	—	10	25	ns	
SP31	TdoR	SDOx Data Output Rise Time ⁽²⁾	—	10	25	ns	
SP35	Tsch2doV, TscL2doV	SDOx Data Output Valid after SCKx Edge	—	—	30	ns	
SP40	TdiV2scH, TdiV2scL	Setup Time of SDIx Data Input to SCKx Edge	20	—	—	ns	
SP41	Tsch2diL, TscL2diL	Hold Time of SDIx Data Input to SCKx Edge	20	—	—	ns	
SP50	TssL2scH, TssL2scL	$\overline{\text{SSx}}$ to SCKx \uparrow or SCKx Input	120	—	—	ns	
SP51	TssH2doZ	$\overline{\text{SSx}}$ \uparrow to SDOx Output High-Impedance ⁽³⁾	10	—	50	ns	
SP52	Tsch2ssH TscL2ssH	$\overline{\text{SSx}}$ after SCKx Edge	50	—	—	ns	

10. Instructions Table

10.1. UART Mode

Text Mode

Instruction of text mode

1	2	3	4	5	6	7	8	9	10	11	12	13	14	15	16	17	18	19	20	21
SB 1	PL	SB 2	SB 3	M D	W R	TR	X H	XL	Y H	YL	S R	S G	SB	B R	B G	B B	TA SDA	EB 1	EB 2	EB 3

Graphic Mode

Instruction of Graphic mode:

1	2	3	4	5	6	7	8	9	10	11	12	13	14	15	16
SB1	PL	SB2	SB3	MD	RR	XH	XL	YH	YL	PH	PL	EB1	EB2	EB3	SB1

Pixel Mode

Instruction of Pixel mode

1	2	3	4	5	6	7	8	9	10	11	12	13	14	15	16
SB1	PL	SB2	SB3	MD	RR	XH	XL	YH	YL	PR	PG	PB	EB1	EB2	EB3

Geometry Mode

Instruction of geometry mode

1	2	3	4	5	6	7	8	9	10	11	12	13	14	15	16	17	18	19	20	21
SB 1	PL	SB 2	SB 3	M D	R R	XS H	XS L	YS H	YS L	XE H	XE L	YE H	YE L	LS	LR	LG	LB	EB 1	EB 2	EB 3

Clean Mode

Instruction of Clean Mode

1	2	3	4	5	6	7	8	9	10	11	12	13	14	15	16
SB1	PL	SB 2	SB 3	MD	XSH	XSL	YSH	YSL	XEH	XEL	YEH	YEL	EB1	EB2	EB3

PWM Mode

Instruction of Pixel mode

1	2	3	4	5	6	7	8	9	10	11	12	13
SB1	PL	SB2	SB3	MD	PS	PFH	PFL	PDH	PDL	EB1	EB2	EB3

Backlight Mode

Instruction of Clean Mode

1	2	3	4	5	6	7	8	9	10	11	12	13	14	15	16
SB1	PL	SB2	SB3	MD	RR	XH	XL	YH	YL	PR	PG	PB	EB1	EB2	EB3

10.2. SPI Mode

Text Mode

Instruction of text mode

1	2	3	4	5	6	7	8	9	10	11	12	13	14	15	16
0x31	SB 3	MD	WR	TR	XH	XL	YH	YL	SR	SG	SB	BR	BG	B B	SDA TA

Graphic Mode

Instruction of Graphic mode:

1	2	3	4	5	6	7	8	9	10
0x31	SB3	MD	RR	XH	XL	YH	YL	PH	PL

Pixel Mode

Instruction of Pixel mode

1	2	3	4	5	6	7	8	9	10	11
0x31	SB3	MD	RR	XH	XL	YH	YL	PR	PG	PB

Geometry Mode

Instruction of geometry mode

1	2	3	4	5	6	7	8	9	10	11	12	13	14	15	16
0x31	SB 3	MD	RR	XS H	XSL	YS H	YSL	XE H	XEL	YE H	YEL	LS	LR	LG	LB

Clean Mode

Instruction of Clean Mode

1	2	3	4	5	6	7	8	9	10	11
0x31	SB3	MD	XSH	XSL	YSH	YSL	XEH	XEL	YEH	YEL

PWM Mode

Instruction of Pixel mode

1	2	3	4	5	6	7	8
0x31	SB3	MD	PS	PFH	PFL	PDH	PDL

Backlight Mode

Instruction of Clean Mode

1	2	3	4	5	6	7	8	9	10	11
0x31	SB3	MD	RR	XH	XL	YH	YL	PR	PG	PB

11. Optical Characteristics

Item	Symbol	Condition.	Min	Typ.	Max.	Unit	Remark	
Response time	Tr	$\theta=0^\circ$ 、 $\phi=0^\circ$	-	10		.ms	Note 3	
	Tf		-	15		.ms		
Contrast ratio	CR	At optimized viewing angle	300	350	-	-	Note 4	
Color Chromaticity	White	$\theta=0^\circ$ 、 $\phi=0$	Wx	0.26	0.31	0.36		Note 2,6,7
			Wy	0.28	0.33	0.38		
Viewing angle (Gray Scale Inversion Direction)	Hor.	$CR \geq 10$	θ_R	-	55		Deg.	Note 1
			θ_L	-	55			
	Ver.		ϕ_T	-	45			
			ϕ_B	-	50			
Brightness	-	-	250	300	-	cd/m2	Center of display	
Uniformity	(U)	-	75	-	-	%	Note 5	

Ta=25±2°C, VDD/IDD=5V/160mA

Note 1: Definition of viewing angle range

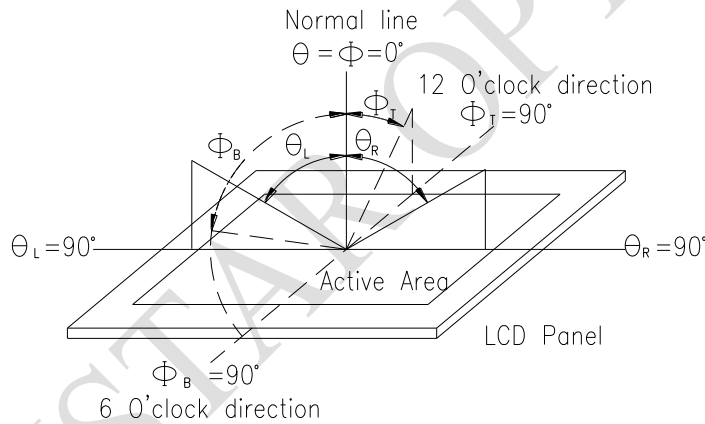

Fig. 11.1. Definition of viewing angle

Note 2: Test equipment setup:

After stabilizing and leaving the panel alone at a driven temperature for 10 minutes, the measurement should be executed. Measurement should be executed in a stable, windless, and dark room. Optical specifications are measured by Topcon BM-7orBM-5 luminance meter 1.0° field of view at a distance of 50cm and normal direction.

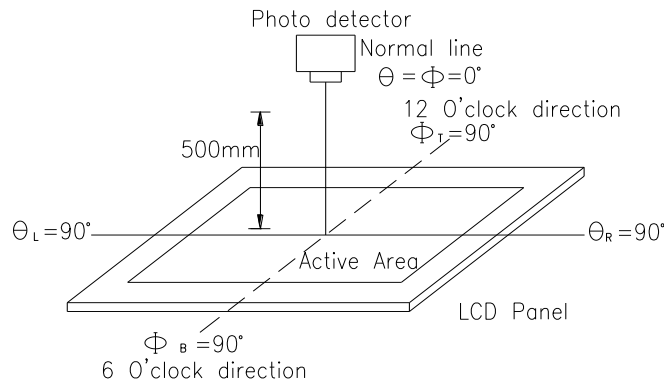
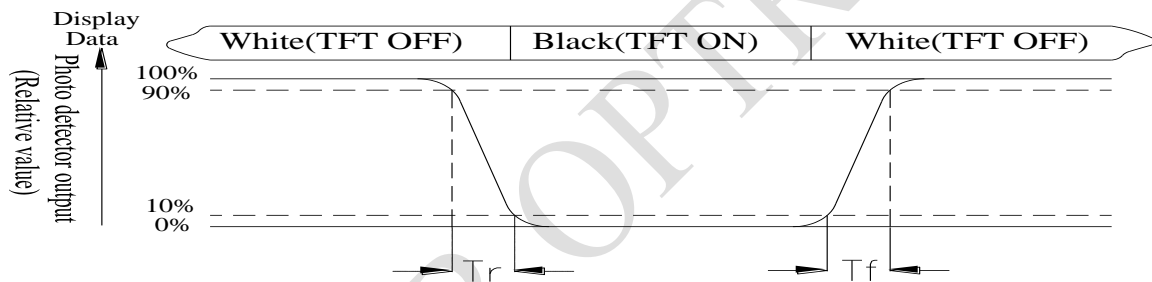

Fig. 11.2. Optical measurement system setup

Note 3: Definition of Response time:

The response time is defined as the LCD optical switching time interval between “White” state and “Black” state. Rise time, T_r , is the time between photo detector output intensity changed from 90% to 10%. And fall time, T_f , is the time between photo detector output intensity changed from 10% to 90%



Note 4: Definition of contrast ratio:

The contrast ratio is defined as the following expression.

$$\text{Contrast ratio (CR)} = \frac{\text{Luminance measured when LCD on the "White" state}}{\text{Luminance measured when LCD on the "Black" state}}$$

Note 5: Definition of Luminance Uniformity

Active area is divided into 9 measuring areas (reference the picture in below). Every measuring point is placed at the center of each measuring area.

$$\text{Luminance Uniformity (U)} = L_{\min}/L_{\max} \times 100\%$$

L = Active area length

W = Active area width

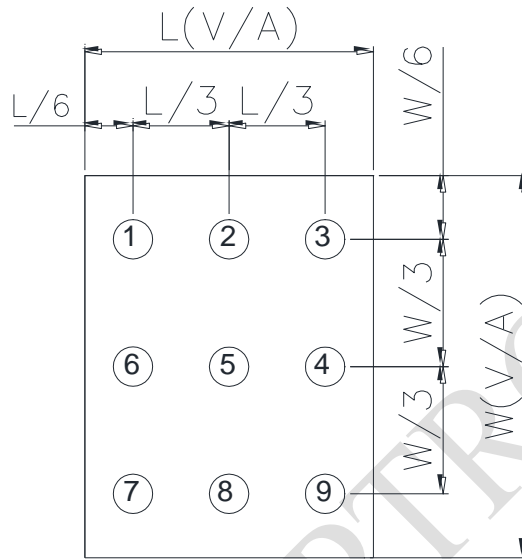

Fig11.3. Definition of uniformity

Note 6: Definition of color chromaticity (CIE 1931)

Color coordinates measured at the center point of LCD

Note 7: Measured at the center area of the panel when all the input terminals of LCD panel are electrically opened.

12. Reliability

Content of Reliability Test (Wide temperature, -20°C ~70°C)

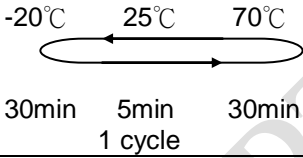
Environmental Test			
Test Item	Content of Test	Test Condition	Note
High Temperature storage	Endurance test applying the high storage temperature for a long time.	80°C 200hrs	2
Low Temperature storage	Endurance test applying the low storage temperature for a long time.	-30°C 200hrs	1,2
High Temperature Operation	Endurance test applying the electric stress (Voltage & Current) and the thermal stress to the element for a long time.	70°C 200hrs	—
Low Temperature Operation	Endurance test applying the electric stress under low temperature for a long time.	-20°C 200hrs	1
High Temperature/ Humidity Operation	The module should be allowed to stand at 60°C, 90%RH max	60°C, 90%RH 96hrs	1,2
Thermal shock resistance	The sample should be allowed stand the following 10 cycles of operation <div style="text-align: center;">  <p>-20°C 25°C 70°C</p> <p>30min 5min 30min</p> <p>1 cycle</p> </div>	-20°C/70°C 10 cycles	—
Vibration test	Endurance test applying the vibration during transportation and using.	Total fixed amplitude : 1.5mm Vibration Frequency : 10~55Hz One cycle 60 seconds to 3 directions of X,Y,Z for Each 15 minutes	3
Static electricity test	Endurance test applying the electric stress to the terminal.	VS=±600V(contact) ,±800v(air), RS=330Ω CS=150pF 10 times	—

Note1: No dew condensation to be observed.

Note2: The function test shall be conducted after 4 hours storage at the normal Temperature and humidity after remove from the test chamber.

Note3: The packing have to including into the vibration testing.

13.Touch Panel Information

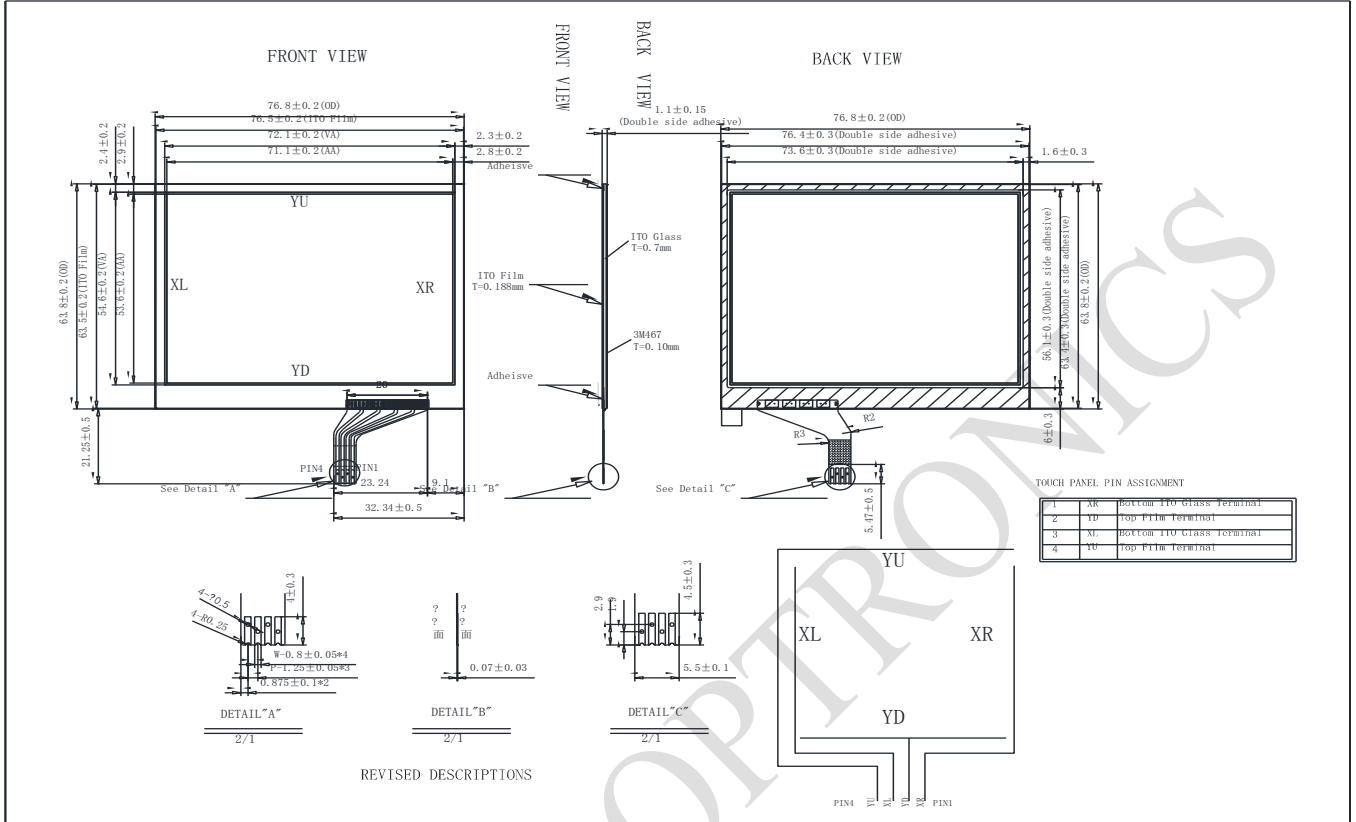

13.1. Resistance Touch Panel General Specifications

Item	Description
Driving condition	DC5V
Operating force	60~150g
Linearity max	$\leq \pm 1.5\%$
Insulating resistance	$> 20M\Omega$, 25V(DC)
Light transparence	70%
Structure type	ITO Film/ITO Glass(F/G)
Surface Hardness	3H typ
Pen Hitting Durability (with the silicon rubber)	$> 1000,000$ times
X resistance	200~1100 Ω
Y resistance	200~1100 Ω

RAYSTAR OPTRONICS

14. Relationship

14.1. Commands Reference Guide

If you want to know the details of how to use the command, you can see the PDF named M-series TFT Commands Reference Guide.

14.2. User Guide

If you want to learn more about how to use UI software, you can see the PDF named M-Series User Guide.

RAYSTAR OPTRONICS

LCM Sample Estimate Feedback Sheet

Module Number : _____

1 、 Panel Specification :

1. Panel Type :	<input type="checkbox"/> Pass	<input type="checkbox"/> NG , _____
2. View Direction :	<input type="checkbox"/> Pass	<input type="checkbox"/> NG , _____
3. Numbers of Dots :	<input type="checkbox"/> Pass	<input type="checkbox"/> NG , _____
4. View Area :	<input type="checkbox"/> Pass	<input type="checkbox"/> NG , _____
5. Active Area :	<input type="checkbox"/> Pass	<input type="checkbox"/> NG , _____
6. Operating Temperature :	<input type="checkbox"/> Pass	<input type="checkbox"/> NG , _____
7. Storage Temperature :	<input type="checkbox"/> Pass	<input type="checkbox"/> NG , _____
8. Others :	_____	

2 、 Mechanical Specification :

1. PCB Size :	<input type="checkbox"/> Pass	<input type="checkbox"/> NG , _____
2. Frame Size :	<input type="checkbox"/> Pass	<input type="checkbox"/> NG , _____
3. Material of Frame :	<input type="checkbox"/> Pass	<input type="checkbox"/> NG , _____
4. Connector Position :	<input type="checkbox"/> Pass	<input type="checkbox"/> NG , _____
5. Fix Hole Position :	<input type="checkbox"/> Pass	<input type="checkbox"/> NG , _____
6. Backlight Position :	<input type="checkbox"/> Pass	<input type="checkbox"/> NG , _____
7. Thickness of PCB :	<input type="checkbox"/> Pass	<input type="checkbox"/> NG , _____
8. Height of Frame to PCB :	<input type="checkbox"/> Pass	<input type="checkbox"/> NG , _____
9. Height of Module :	<input type="checkbox"/> Pass	<input type="checkbox"/> NG , _____
10. Others :	<input type="checkbox"/> Pass	<input type="checkbox"/> NG , _____

3 、 Relative Hole Size :

1. Pitch of Connector :	<input type="checkbox"/> Pass	<input type="checkbox"/> NG , _____
2. Hole size of Connector :	<input type="checkbox"/> Pass	<input type="checkbox"/> NG , _____
3. Mounting Hole size :	<input type="checkbox"/> Pass	<input type="checkbox"/> NG , _____
4. Mounting Hole Type :	<input type="checkbox"/> Pass	<input type="checkbox"/> NG , _____
5. Others :	<input type="checkbox"/> Pass	<input type="checkbox"/> NG , _____

4 、 Backlight Specification :

1. B/L Type :	<input type="checkbox"/> Pass	<input type="checkbox"/> NG , _____
2. B/L Color :	<input type="checkbox"/> Pass	<input type="checkbox"/> NG , _____
3. B/L Driving Voltage (Reference for LED Type) :	<input type="checkbox"/> Pass	<input type="checkbox"/> NG , _____
4. B/L Driving Current :	<input type="checkbox"/> Pass	<input type="checkbox"/> NG , _____
5. Brightness of B/L :	<input type="checkbox"/> Pass	<input type="checkbox"/> NG , _____
6. B/L Solder Method :	<input type="checkbox"/> Pass	<input type="checkbox"/> NG , _____
7. Others :	<input type="checkbox"/> Pass	<input type="checkbox"/> NG , _____

>> **Go to page 2** <<

Module Number : _____		
5 · <u>Electronic Characteristics of Module</u> :		
1.Input Voltage :	<input type="checkbox"/> Pass	<input type="checkbox"/> NG , _____
2.Supply Current :	<input type="checkbox"/> Pass	<input type="checkbox"/> NG , _____
3.Driving Voltage for LCD :	<input type="checkbox"/> Pass	<input type="checkbox"/> NG , _____
4.Contrast for LCD :	<input type="checkbox"/> Pass	<input type="checkbox"/> NG , _____
5.B/L Driving Method :	<input type="checkbox"/> Pass	<input type="checkbox"/> NG , _____
6.Negative Voltage Output :	<input type="checkbox"/> Pass	<input type="checkbox"/> NG , _____
7.Interface Function :	<input type="checkbox"/> Pass	<input type="checkbox"/> NG , _____
8.LCD Uniformity :	<input type="checkbox"/> Pass	<input type="checkbox"/> NG , _____
9.ESD test :	<input type="checkbox"/> Pass	<input type="checkbox"/> NG , _____
10.Others :	<input type="checkbox"/> Pass	<input type="checkbox"/> NG , _____
6 · <u>Summary</u> :		
<p style="text-align: right;"> Sales signature : _____ Customer Signature : _____ Date : / / _____ </p>		

X-ON Electronics

Largest Supplier of Electrical and Electronic Components

Click to view similar products for [TFT Displays & Accessories](#) category:

Click to view products by [Raystar](#) manufacturer:

Other Similar products are found below :

[OAI-80038AA-2013-A](#) [HDA430T-3G1H](#) [EA CARREDIPTFT02](#) [NL6448BC20-21D](#) [TM022HDHT11-00](#) [NB7W-KBA04](#) [NB-ATT01](#)
[NB5Q-ATT01](#) [NB5Q-KBA04](#) [NB-CN001](#) [NL12880BC20-05](#) [NL8060BC26-35C](#) [NL8060BC26-35F](#) [TCG104SVLQAPNN-AN20](#) [OAI-](#)
[80038AA-2008-A](#) [315-U004B15300](#) [UMSH-8596MD-34T \(REV D\)](#) [98-0003-3490-8](#) [1044278](#) [1029309](#) [1060549](#) [DE 127-TU-30/7,5](#) [DE](#)
[128-TU-20/7,5](#) [EP-LK007TFTPCAP](#) [FR7.0A00](#) [RC2002A-TIG-CSX](#) [NL6448BC2021C](#) [TX17D01VM2EAB](#) [TX14D23VM5BAA](#)
[TCG121WXLRXVNNANX35](#) [EIC-LCD-1080P](#) [T272480C07VR01](#) [1060632](#) [TCG070WVLPAANN-AN50](#) [TCG035QVLPDANN-GN50](#)
[1060630](#) [RFE430V-AIW-DNG](#) [T-55619GD065J-LW-ABN](#) [NHD-1.8-128160EF-SSXN-FT](#) [TCG104SVLPEANN-AN30](#) [NL6448BC33-70](#)
[NL192108BC18-06F](#) [NLB150XG02L-01](#) [NL6448BC20-30D](#) [NL10276BC16-06](#) [NL192108AC10-01D](#) [NL6448AC18-08F](#) [NL6448BC20-30F](#)
[NL12880BC20-05BD](#) [NL12880BC20-05D](#)