



**RAYSTAR**

# 曜凌光電股份有限公司

住址: 42878 台中市大雅区科雅路 25 號 5F WEB: <http://www.Raystar-Optronics.com>  
5F., No.25, Keya Rd., Daya Dist., Taichung E-mail: [sales@raystar-optronics.com](mailto:sales@raystar-optronics.com)  
City 428, Taiwan Tel:886-4-2565-0761 Fax : 886-4-2565-0760

## RFC57AP-EIW-DBG

---

---

### SPECIFICATION

CUSTOMER:

<b>APPROVED BY</b>	
<b>PCB VERSION</b>	
<b>DATE</b>	

FOR CUSTOMER USE ONLY

<b>SALES BY</b>	<b>APPROVED BY</b>	<b>CHECKED BY</b>	<b>PREPARED BY</b>

Release DATE:

TFT Display Inspection Specification: <https://www.raystar-optronics.com/download/products.htm>

Precaution in use of TFT module: <https://www.raystar-optronics.com/download/declaration.htm>

---

---

## Revision History

VERSION	DATE	REVISED PAGE NO.	Note
0	2018/08/31		First issue
A	2019/05/06		Modify CTP FW Version

RAYSTAR OPTRONICS

# Contents

1. Module Classification Information
2. Summary
3. General Specification
4. Interface
5. Contour Drawing
6. Block Diagram
7. Absolute Maximum Ratings
8. Electrical Characteristics
9. DC Characteristics
10. AC Characteristics
11. Optical Characteristics
12. Reliability
13. Touch Panel Information
14. Initial Code For Reference
15. Other

# 1.Module Classification Information

<b>R</b>	<b>F</b>	<b>C</b>	<b>57</b>	<b>AP</b>	<b>-</b>	<b>E</b>	<b>I</b>	<b>W</b>	<b>-</b>	<b>D</b>	<b>B</b>	<b>G</b>
1	2	3	4	5	-	6	7	8	-	9	10	11

Item	Description	
1	R : Raystar Optronics Inc.	
2	Display Type : F→TFT Type, J→ Custom TFT	
3	Solution: A: 128x160    B:320x234    C:320x240    D:480x234    E:480x272 F:800x480    G:640x480    H:1024x600    I:320x480    J:240x320 K:1280x800    L:240x400    M:1024x768    N:128x128    O:480x800 P:640x320    Q:800x600    S:480x128    T:800x320	
4	Display Size : 5.7" TFT	
5	Version Code.	
6	Model Type: A : TFT LCD E : TFT+FR+CONTROL BOARD J : TFT+FR+A/D BOARD N : TFT+FR+A/D BOARD+CONTROL BOARD S : TFT+FR+POWER BOARD (DC TO DC) 1 : TFT+CONTROL BOARD	6 : TFT+FR H : TFT+D/V BOARD I : TFT+FR+D/V BOARD B : TFT+POWER BD
7	Polarizer Type, Temperature range, View direction	I→Transmissive, W. T, 6:00 ;    C→Transmissive, N. T, 6:00 L→Transmissive, W.T,12:00 ;    F→Transmissive, N.T,12:00 Y→Transmissive,W.T, IPS TFT ; A→Transmissive, N.T, IPS TFT Z→Transmissive, W.T, O-TFT R→Transmissive, Super W.T, O-TFT N→Transmissive, Super W.T, 6:00; Q→Transmissive, Super W.T, 12:00 V→Transmissive, Super W.T, VA TFT
8	Backlight	W : LED, White                      H : LED, High Light White F : CCFL, White
9	Driver Method	D: Digital    A: Analog    L : LVDS    M:MIPI
10	Interface	N : without control board    A : 8Bit    B : 16Bit S:SPI Interface    R: RS232    U:USB    I: I2C
11	TS	N : Without TS    S : resistive touch panel C : capacitive touch panel capacitive touch panel (G-F-F) G : capacitive touch panel(G-G)

## 2.Summary

TFT 5.7" is a TN transmissive type color active matrix TFT liquid crystal display that use amorphous silicon TFT as switching devices. This module is a composed of a TFT\_LCD module, It is usually designed for industrial application and this module follows RoHs,

RAYSTAR OPTRONICS

---

### 3.General Specifications

- Size: 5.7 inch
- Dot Matrix: 320 x RGBx240(TFT) dots
- Module dimension: 141.12 × 101.55 ×14.535 mm
- Active area: 115.2 × 86.4 mm
- Dot pitch: 0.12 × 0.36 mm
- LCD type: TFT, Normally White, Transmissive
- View Direction: 12 o'clock
- Gray Scale Inversion Direction: 6 o'clock
- Aspect Ratio: 4:3
- Backlight Type: LED,Normally White
- Controller IC: RA8875
- Interface: Digital 8080 family MPU
- CTP IC: FT5426 or Equivalent
- CTP Interface: I2C
- CTP FW Version: FN058A001\_FT5426\_\_V03\_20180910\_all.bin
- With /Without TP: With CTP
- Surface: Glare

\*Color tone slight changed by temperature and driving voltage.

## 4.Interface

### 4.1. LCM PIN Definition

#### TFT LCD Panel Driving Section

FPC Connector is used for the module electronics interface.

Pin	Symbol	Function	Remark
1	GND	System ground	
2	VDD	Power Supply : +3.3V	
3	BL_E	PWM control	
4	RS	Data/Command select	
5	WR	Write strobe signal	
6	RD	Read strobe signal	
7	D0	Data bus	
8	D1	Data bus	
9	D2	Data bus	
10	D3	Data bus	
11	D4	Data bus	
12	D5	Data bus	
13	D6	Data bus	
14	D7	Data bus	
15	D8	Data bus	
16	D9	Data bus	
17	D10	Data bus	
18	D11	Data bus	
29	D12	Data bus	
20	D13	Data bus	
21	D14	Data bus	
22	D15	Data bus	
23	WAIT	Wait Signal Output(H:active)	
24	CTP_INT	CTP Interrupt Signal From Touch Panel Module To Host	
25	CS	Chip select	
26	RST	Hardware reset	
27	L/R	Left / right selection; Default L/R=H	Note 2,3
28	U/D	Up/down selection; ; Default U/D=L	Note 2,3
29	CTP_SCL	CTP Serial IIC Clock	
30	CTP_SDA	CTP Serial IIC Data	
31	CTP_RST	CTP Reset Signal	
32	NC	No Connection	
33	VLED-	Power for LED backlight cathode(GND)	
34	VLED-	Power for LED backlight cathode(GND)	
35	VLED+	Power for LED backlight anode(+5V)	
36	VLED+	Power for LED backlight anode(+5V)	

Note1: When select 8bit mode, DB0~DB7 be used, DB8~DB15 no connect  
 When select 16bit mode, DB0~DB15 be used

Note 2: Selection of scanning mode

Setting of scan control input		Scanning direction
U/D	L/R	
GND	VDD	Up to down, left to right
VDD	GND	Down to up, right to left
GND	GND	Up to down, right to left
VDD	VDD	Down to up, left to right

Note 3: Definition of scanning direction. Refer to the figure as below:



U/D=L, L/R=H

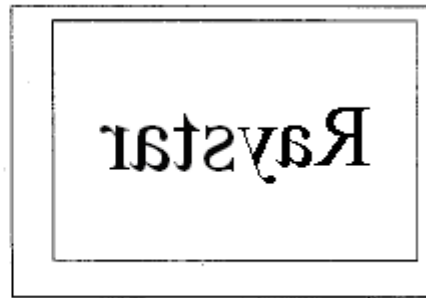

U/D=L, L/R=L

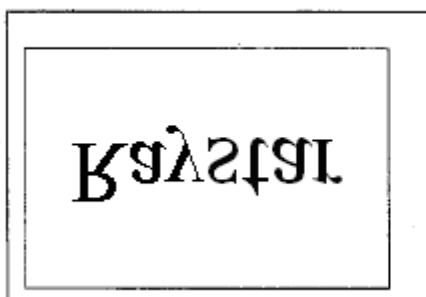

U/D=H, L/R=H

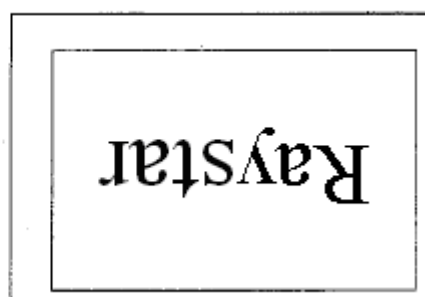

U/D=H, L/R=L



# 5. Contour Drawing

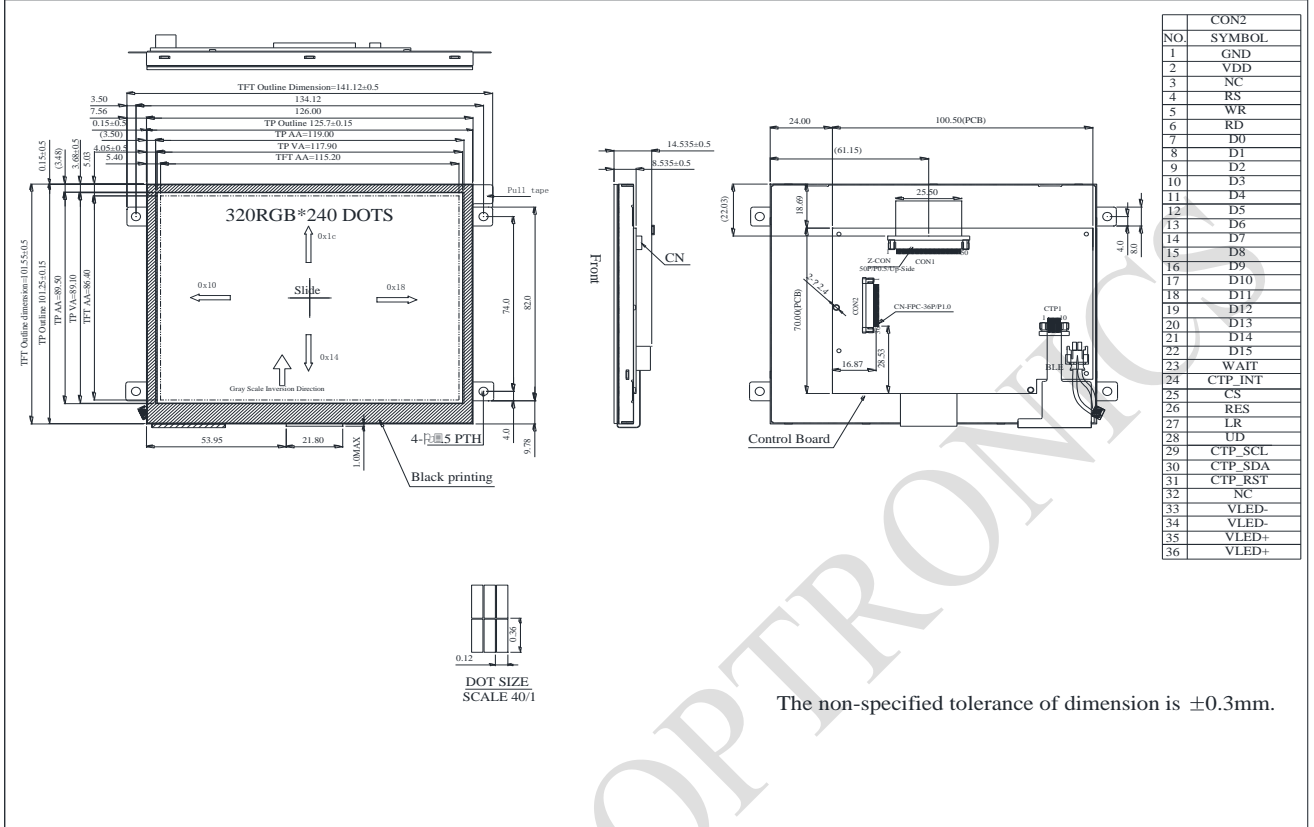

## 6. Block Diagram

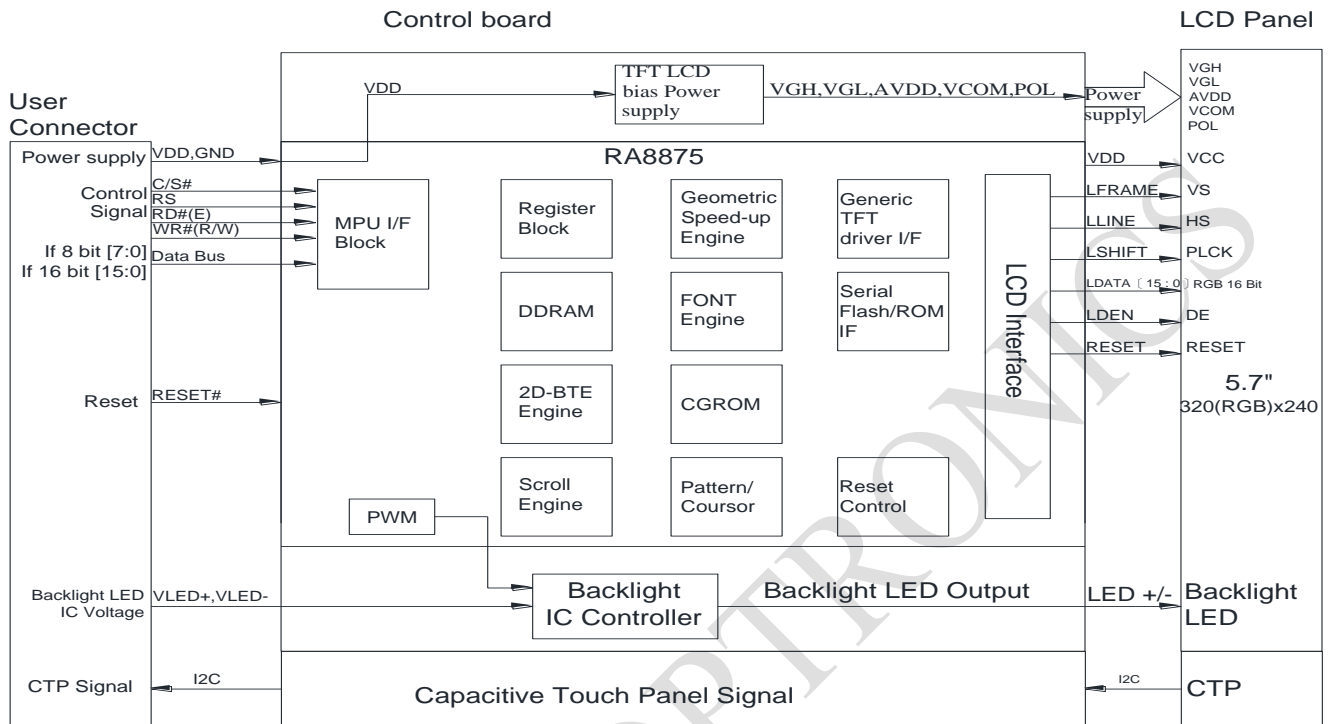

## 7. Absolute Maximum Ratings

Item	Symbol	Values		Unit	Remark
		Min	max		
Power Supply Voltages	VDD	-0.5	3.5	V	
Input signal voltage	Logic input	-0.5	3.5	V	
Operating Temperature	Topa	-20	70	° C	Note3,4
Storage Temperature	Tst	-30	80	° C	Note3,4
LED Reverse Voltage	Vr	-	1.2	V	Each LED Note2
LED Forward Current	IF	-	25	mA	Each LED

Note 1: The absolute maximum rating values of this product are not allowed to be exceeded at any times. A module should be used with any of the absolute maximum ratings exceeded, the characteristics of the module may not be recovered, or in an extreme condition, the module may be permanently destroyed.

Note 2: VR Conditions: Zener Diode 20mA

Note 3: 90% RH Max. (Max wet temp. is 60°C)

Maximum wet-bulb temperature is at 60°C or less. And No condensation (no drops of dew)

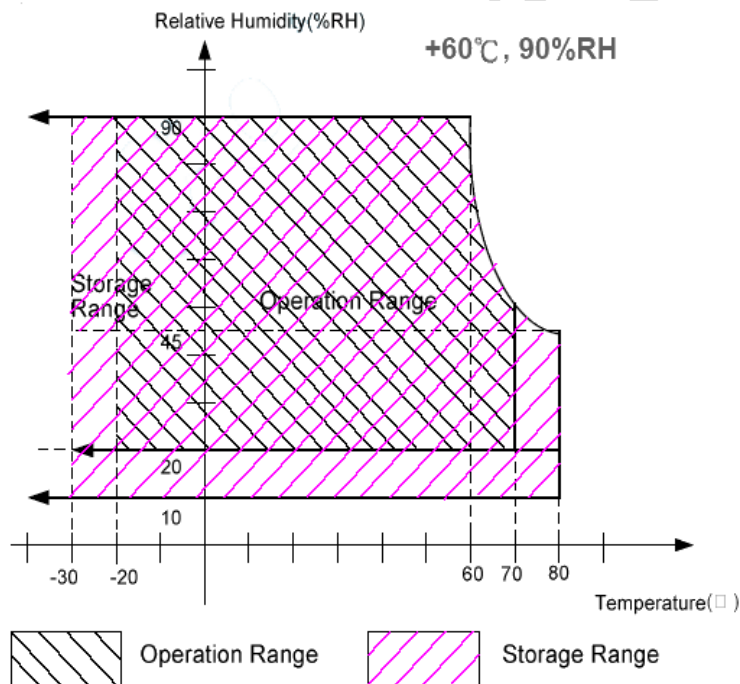

Note 4: In case of temperature below 0°C, the response time of liquid crystal (LC) becomes slower and the color of panel darker than normal one.

## 8. Electrical Characteristics

### 8.1. Typical operation conditions

Item	Symbol	Values			Unit	Remark
		Min	TYP	max		
Power voltage	VDD	3.1	3.3	3.5	V	-
Current of driver	IVDD	-	214	-	mA	VDD =3.3V

### 8.2. Backlight Driving Conditions

Parameter	Symbol	Min.	Typ.	Max.	Unit	Remark
Operation Current For LED Driver	VLED=5V	250	—	375	mA	Note 1,2
Power Consumption	VLED=5V	1250	—	1875	mW	Note 1,2
Supply Voltage For LED Driver	VLED+	—	5	—	V	—
LED Life Time	—	—	50,000	—	Hr	Note 2,3,4

Note 1 : Base on VLED= 5V for the back light driver IC specification

Note 2 : Ta = 25 °C

Note 3 : Brightness to be decreased to 50% of the initial value

Note 4 : The single LED lamp case

### 8.3. Power Sequence

To prevent a latch-up or DC operation of the LCD module, the power on/off sequence should be as the diagram below.

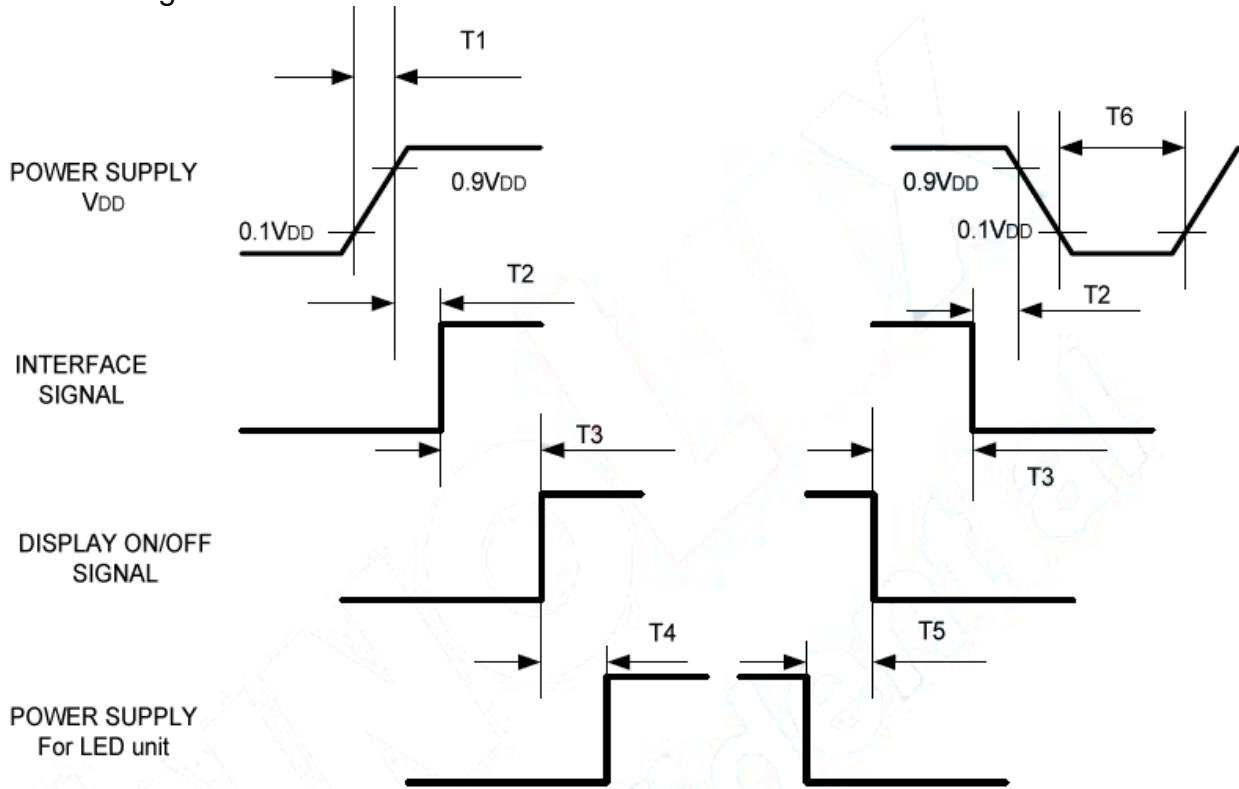

Symbol	Specification	Symbol	Specification
T1	$0 \leq T1 \leq 10 \text{ msec}$	T4	$160 \text{ msec} \leq T4$
T2	$0 \leq T2 \leq 100 \text{ msec}$	T5	$160 \text{ msec} \leq T5$
T3	$0 \leq T3 \leq 200 \text{ msec}$	T6	$1 \text{ msec} \leq T6$

## 9.DC CHARATERISTICS

Parameter	Symbol	Rating			Unit	Condition
		Min	Typ	Max		
Low level input voltage	VIL	GND	-	0.2 VDD	V	
High level input voltage	VIH	0.8 VDD	-	VDD	V	

RAYSTAR OPTRONICS

# 10.AC CHARATERISTICS

## 10.1. Parallel I/F Protocol

The following timing charts are used to describe the timing specification of the standard 8080 and 6800 interfaces.

6800 – 8/16-bit Interface

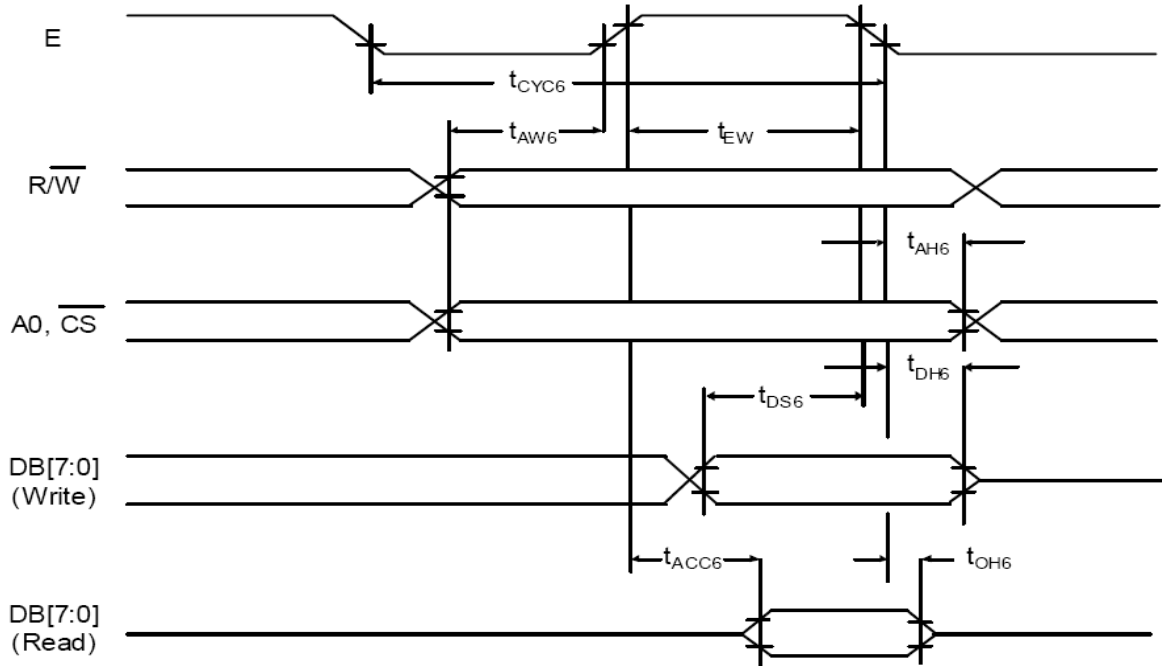

Figure 1: 6800 MCU Waveform

Table 1: 6800 MCU I/F Timing

Symbol	Parameter	Rating		Unit	Symbol
		Min.	Max		
$t_{CYC6}$	Cycle time	50	--	ns	tc is one system clock period: tc = 1/SYS_CLK
$t_{EW}$	Strobe Pulse width	20	--	ns	
$t_{AW6}$	Address setup time	0	--	ns	
$t_{AH6}$	Address hold time	10	--	ns	
$t_{DS6}$	Data setup time	20	--	ns	
$t_{DH6}$	Data hold time	10	--	ns	
$t_{ACC6}$	Data output access time	0	20	ns	
$t_{OH6}$	Data output hold time	0	20	ns	

8080 – 8/16-bit Interface

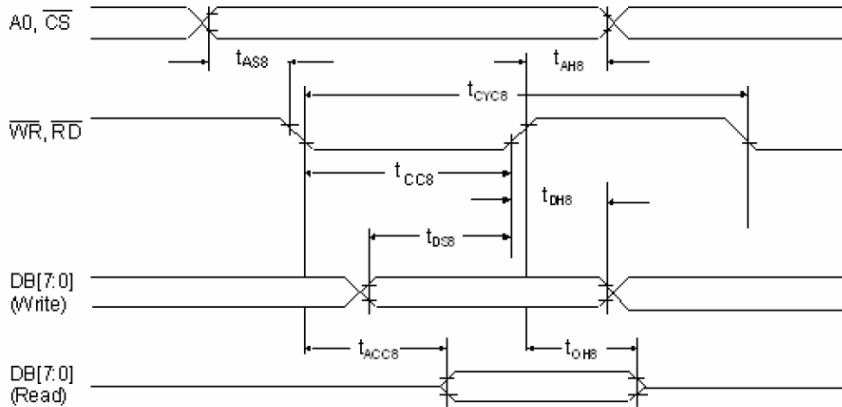

Figure 2: 8080 Waveform  
Table 2: 8080 MCU I/F Timing

Symbol	Parameter	Rating		Unit	Symbol
		Min.	Max.		
tCYC8	Cycle time	50	--	ns	tc is one system clock period: tc = 1/SYS_CLK
tCC8	Strobe Pulse width	20	--	ns	
tAS8	Address setup time	0	--	ns	
tAH8	Address hold time	10	--	ns	
tDS8	Data setup time	20	--	ns	
tDH8	Data hold time	10	--	ns	
tACC8	Data output access time	0	20	ns	
tOH8	Data output hold time	0	20	ns	

The data bus width of RA8875 can be selected to 8-bit/16-bit by setting the Bit [1:0] of SYSR. When Bit [1:0] of SYSR is cleared to “00”, then the data bus is 8-bit. If Bit [1:0] of SYSR is set to

“11”, then the data transition is set as 16-bit. No matter what type of MCU I/F is selected (6800/8080), both of them can be changed the bus width when need. But if the 8-bit is used, it needs double transmission time than 16-bit bus and all of the registers must be accessed by 8-bit data.

The continuous data write speed determines the display update speed. The cycle-to-cycle interval must be larger than 4 times of system clock period. Over the specification may cause the data lose or function fail. Please refer to Figure 6-5 and Figure 6-6 for waveform detail.

In order to reduce the transmission interference between MCU interface and RA8875, It is suggested that a small capacitor to the GND should be added at the signal of CS#, RD#, and WR#. If using cable to connect MCU and RA8875, please keep the cable length less than 20cm. Otherwise it’s suggested to add 1~10Kohm pull-up resistors on pins CS#, RD#, WR# and RS.



MPU6800 Data Write Speed Limit

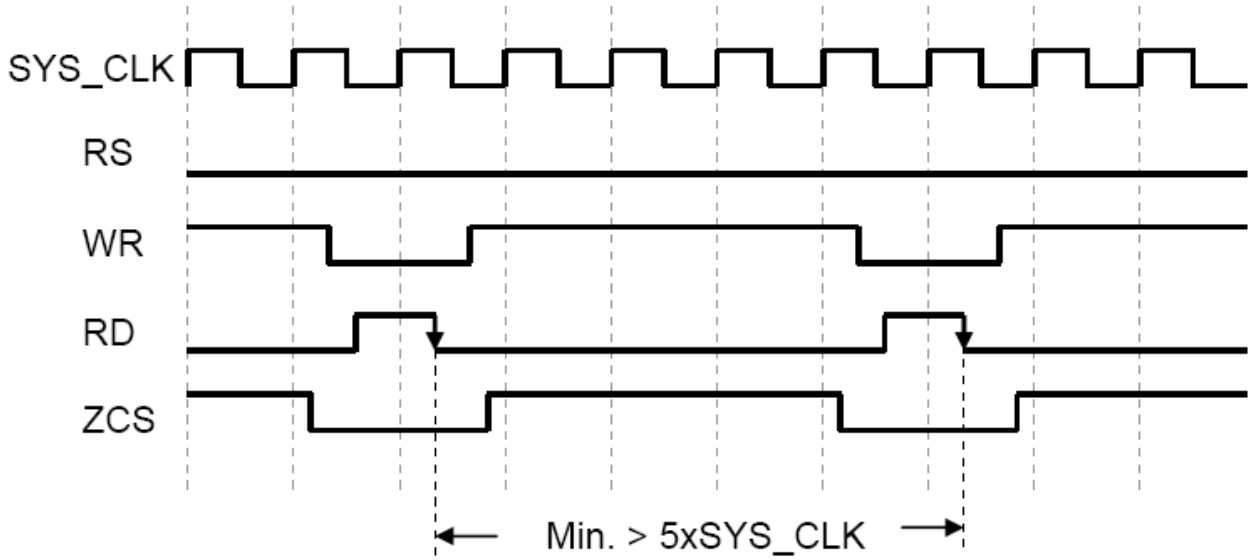

Figure 3: 6800 I/F Continuous Data Write Cycle Waveform

MPU8080 Data Write Speed Limit

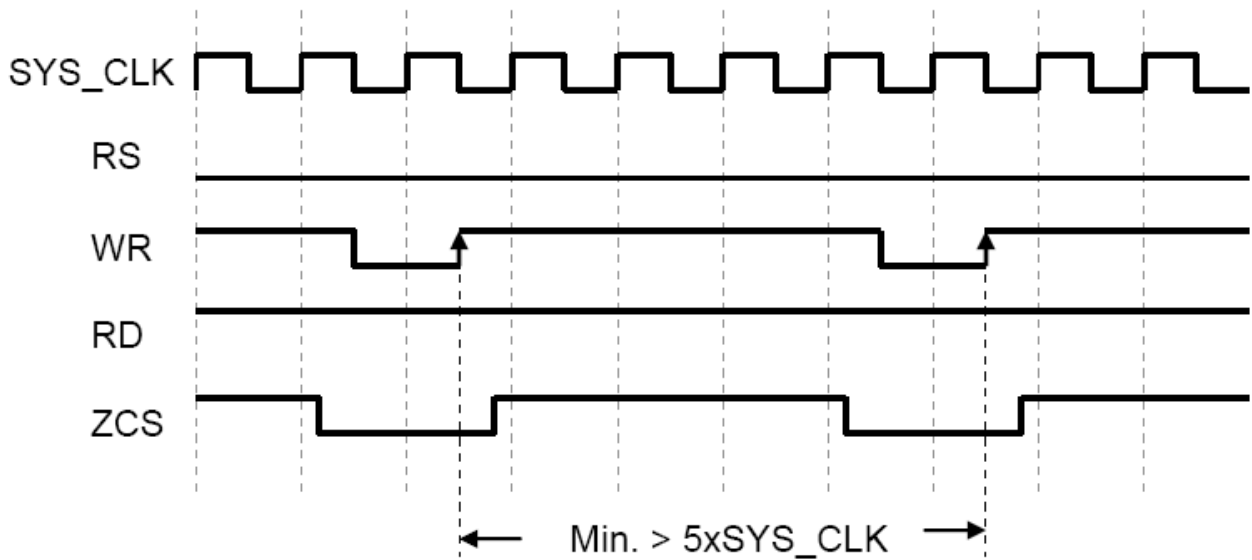

Figure4: 8080 I/F Continuous Data Write Cycle Waveform

### 10.2. Data transfer order Setting

MCU Data Bus 8-Bit

The following illustration is used for 16-bit MCU.

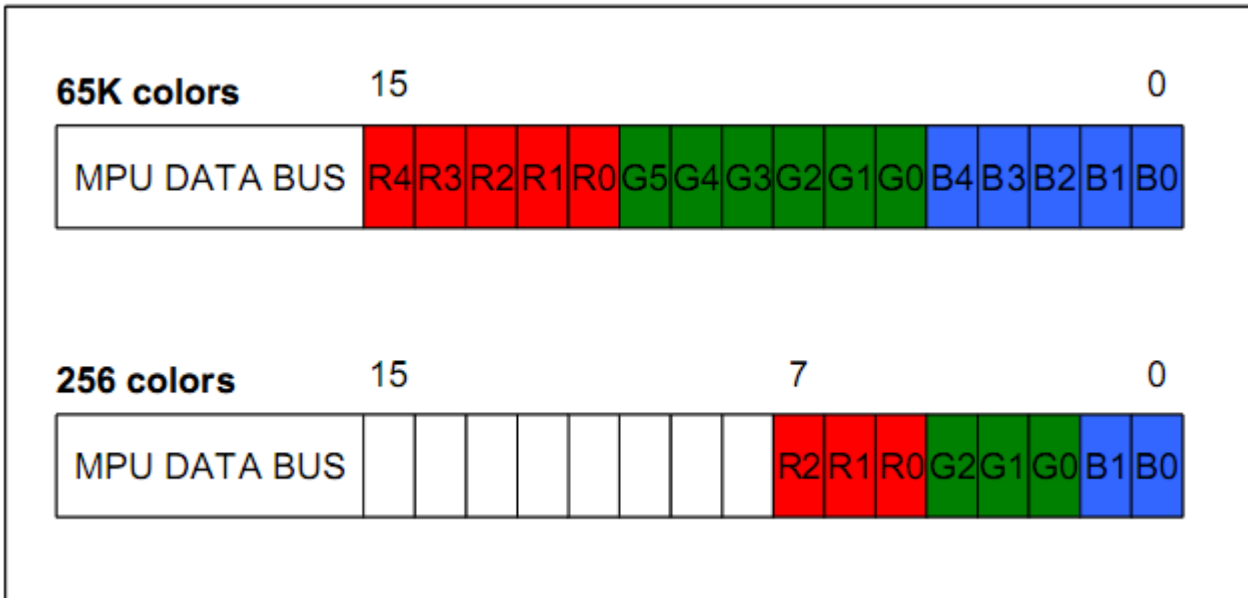

Figure 5: Color illustrations for 16-Bit Data Bus MCU

### 10.3. Register Depiction

Please consult the spec of RA8875

Please consult the spec of FOCALTECH FT5x06

## 11. Optical Characteristics

Item	Symbol	Condition.	Min	Typ.	Max.	Unit	Remark
Response time	Tr	$\theta=0^\circ$ 、 $\phi=0^\circ$	-	15	30	ms	Note 3
	Tf		-	35	50	ms	
Contrast ratio	CR	At optimized viewing angle	150	250	-	-	Note 4
Color Chromaticity	White	Wx	$\theta=0^\circ$ 、 $\phi=0$	0.282	0.312	0.342	Note 2,5,6
		Wy		0.319	0.349	0.379	
Viewing angle (Gray Scale Inversion Direction)	Hor.	$\Theta_R$	CR $\geq 10$	60	70	-	Note 1
		$\Theta_L$		60	70	-	
	Ver.	$\Phi_T$		40	50	-	
		$\Phi_B$		60	70	-	
Brightness	-	-	600	700	-	cd/m <sup>2</sup>	Center Of Display
Uniformity	(U)	-	75	-	-	%	Note5

Ta=25±2°C, VLED / ILED= 5V / 250mA

Note 1: Definition of viewing angle range

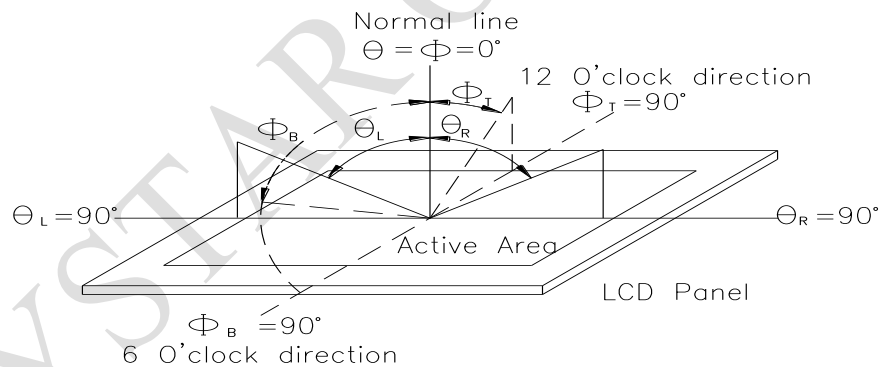

Fig. 11.1. Definition of viewing angle

Note 2: Test equipment setup:

After stabilizing and leaving the panel alone at a driven temperature for 10 minutes, the measurement should be executed. Measurement should be executed in a stable, windless, and dark room. Optical specifications are measured by Topcon BM-7 or BM-5 luminance meter 1.0° field of view at a distance of 50cm and normal direction.

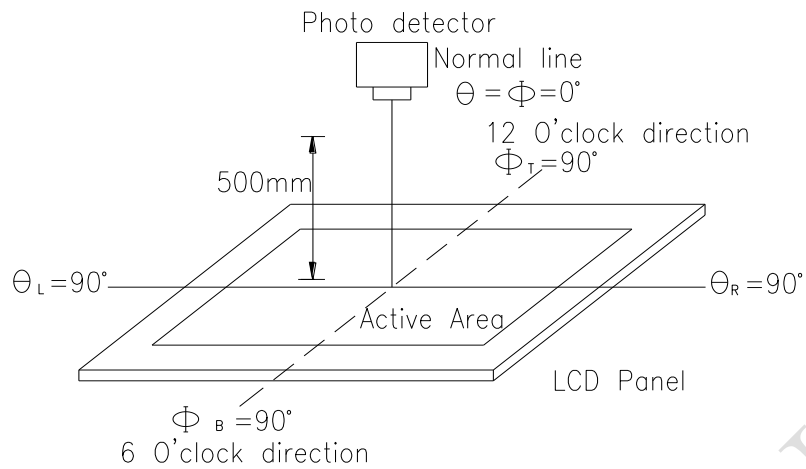
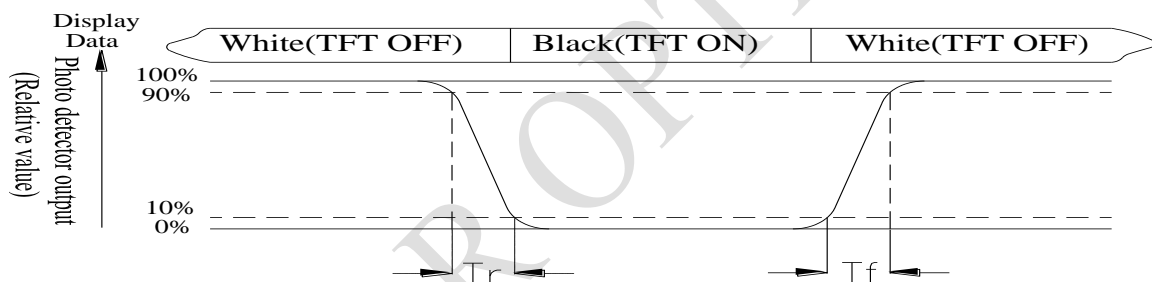

Fig. 11.2. Optical measurement system setup

Note 3: Definition of Response time:

The response time is defined as the LCD optical switching time interval between “White” state and “Black” state. Rise time,  $T_r$ , is the time between photo detector output intensity changed from 90% to 10%. And fall time,  $T_f$ , is the time between photo detector output intensity changed from 10% to 90%



Note 4: Definition of contrast ratio:

The contrast ratio is defined as the following expression.

$$\text{Contrast ratio (CR)} = \frac{\text{Luminance measured when LCD on the "White" state}}{\text{Luminance measured when LCD on the "Black" state}}$$

Note 5: Definition of Luminance Uniformity

Active area is divided into 9 measuring areas (reference the picture in below). Every measuring point is placed at the center of each measuring area.

Luminance Uniformity (U) =  $L_{min}/L_{max} \times 100\%$

L = Active area length

W = Active area width

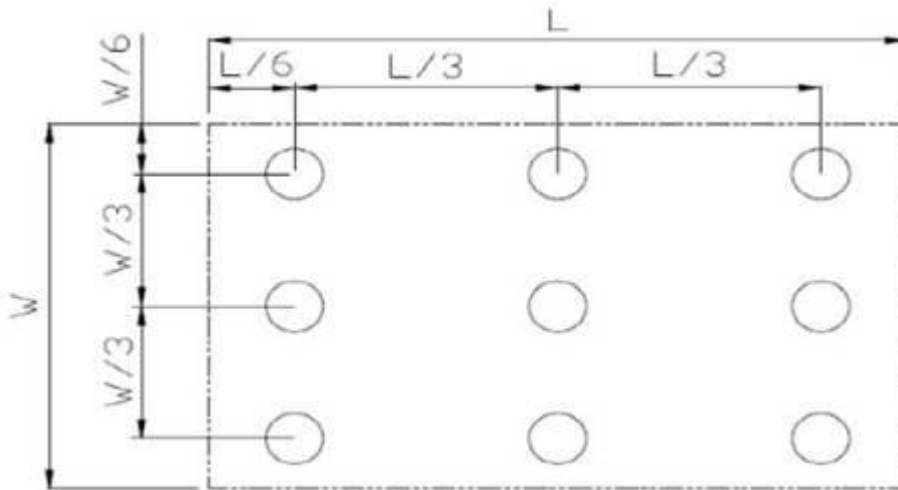

Fig11.3. . . Definition of uniformity

Note 6: Definition of color chromaticity (CIE 1931)

Color coordinates measured at the center point of LCD

Note 7: Measured at the center area of the panel when all the input terminals of LCD panel are electrically opened.

## 12. Reliability

Content of Reliability Test (Wide temperature, -20°C ~70°C)

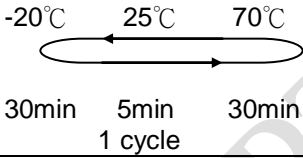
Environmental Test			
Test Item	Content of Test	Test Condition	Note
High Temperature storage	Endurance test applying the high storage temperature for a long time.	80°C 200hrs	2
Low Temperature storage	Endurance test applying the low storage temperature for a long time.	-30°C 200hrs	1,2
High Temperature Operation	Endurance test applying the electric stress (Voltage & Current) and the thermal stress to the element for a long time.	70°C 200hrs	—
Low Temperature Operation	Endurance test applying the electric stress under low temperature for a long time.	-20°C 200hrs	1
High Temperature/ Humidity Operation	The module should be allowed to stand at 60°C, 90%RH max	60°C, 90%RH 96hrs	1,2
Thermal shock resistance	The sample should be allowed stand the following 10 cycles of operation  <div style="text-align: center;">  <p>-20°C    25°C    70°C</p> <p>30min    5min    30min</p> <p>1 cycle</p> </div>	-20°C/70°C 10 cycles	—
Vibration test	Endurance test applying the vibration during transportation and using.	Total fixed amplitude : 1.5mm Vibration Frequency : 10~55Hz One cycle 60 seconds to 3 directions of X,Y,Z for Each 15 minutes	3
Static electricity test	Endurance test applying the electric stress to the terminal.	VS=±600V(contact) ,±800v(air), RS=330Ω CS=150pF 10 times	—

Note1: No dew condensation to be observed.

Note2: The function test shall be conducted after 4 hours storage at the normal Temperature and humidity after remove from the test chamber.

Note3: The packing have to including into the vibration testing.

### 13.Touch Panel Information

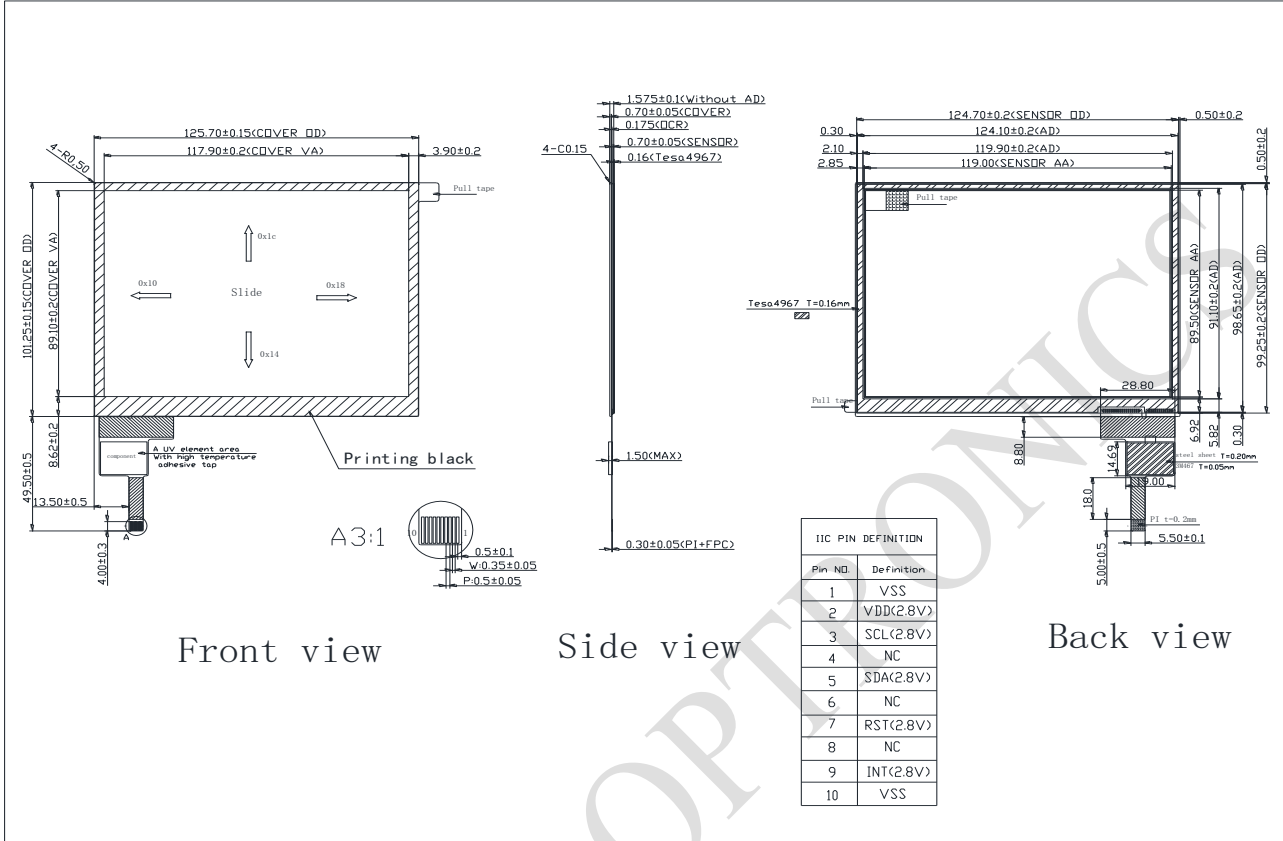

## 14.Initial Code For Reference

```
void Initial_RA8875()
{
    RES = 1;
    Delay1ms (10);
    RES = 0;      //Active low
    Delay1ms (50);
    RES = 1;
    Delay1ms (100);

    LCD_CmdWrite(0x88);
    LCD_DataWrite(0x0a);
    Delay1ms(1);
    LCD_CmdWrite(0x89);
    LCD_DataWrite(0x02);
    Delay1ms(1);

    LCD_CmdWrite(0x10);
    LCD_DataWrite(0x0F);
    LCD_CmdWrite(0x04);
    LCD_DataWrite(0x01);
    Delay1ms(1);

    //Horizontal set
    LCD_CmdWrite(0x14);
    LCD_DataWrite(0x27);
    LCD_CmdWrite(0x15);
    LCD_DataWrite(0x80);
    LCD_CmdWrite(0x16);
    LCD_DataWrite(0x03);
    LCD_CmdWrite(0x17);
    LCD_DataWrite(0x02);
    LCD_CmdWrite(0x18);
    LCD_DataWrite(0x03);

    //Vertical set
    LCD_CmdWrite(0x19);
    LCD_DataWrite(0xef);
    LCD_CmdWrite(0x1a);
    LCD_DataWrite(0x00);
    LCD_CmdWrite(0x1b);
    LCD_DataWrite(0x0f);
    LCD_CmdWrite(0x1c);
    LCD_DataWrite(0x00);
    LCD_CmdWrite(0x1d);
    LCD_DataWrite(0x0e);
    LCD_CmdWrite(0x1e);
    LCD_DataWrite(0x06);
}
```



```
LCD_CmdWrite(0x1f);  
LCD_DataWrite(0x01);
```

```
//Active window set  
//setting active window X  
LCD_CmdWrite(0x30);  
LCD_DataWrite(0x00);  
LCD_CmdWrite(0x31);  
LCD_DataWrite(0x00);  
LCD_CmdWrite(0x34);  
LCD_DataWrite(0x3F);  
LCD_CmdWrite(0x35);  
LCD_DataWrite(0x01);
```

```
//setting active window Y  
LCD_CmdWrite(0x32);  
LCD_DataWrite(0x00);  
LCD_CmdWrite(0x33);  
LCD_DataWrite(0x00);  
LCD_CmdWrite(0x36);  
LCD_DataWrite(0xeF);  
LCD_CmdWrite(0x37);  
LCD_DataWrite(0x00);
```

```
}
```

RAYSTAR OPTRONICS

**LCM Sample Estimate Feedback Sheet**

**Module Number :** \_\_\_\_\_

**1 、 Panel Specification :**

1. Panel Type :	<input type="checkbox"/> Pass	<input type="checkbox"/> NG , _____
2. View Direction :	<input type="checkbox"/> Pass	<input type="checkbox"/> NG , _____
3. Numbers of Dots :	<input type="checkbox"/> Pass	<input type="checkbox"/> NG , _____
4. View Area :	<input type="checkbox"/> Pass	<input type="checkbox"/> NG , _____
5. Active Area :	<input type="checkbox"/> Pass	<input type="checkbox"/> NG , _____
6. Operating Temperature :	<input type="checkbox"/> Pass	<input type="checkbox"/> NG , _____
7. Storage Temperature :	<input type="checkbox"/> Pass	<input type="checkbox"/> NG , _____
8. Others :	_____	

**2 、 Mechanical Specification :**

1. PCB Size :	<input type="checkbox"/> Pass	<input type="checkbox"/> NG , _____
2. Frame Size :	<input type="checkbox"/> Pass	<input type="checkbox"/> NG , _____
3. Material of Frame :	<input type="checkbox"/> Pass	<input type="checkbox"/> NG , _____
4. Connector Position :	<input type="checkbox"/> Pass	<input type="checkbox"/> NG , _____
5. Fix Hole Position :	<input type="checkbox"/> Pass	<input type="checkbox"/> NG , _____
6. Backlight Position :	<input type="checkbox"/> Pass	<input type="checkbox"/> NG , _____
7. Thickness of PCB :	<input type="checkbox"/> Pass	<input type="checkbox"/> NG , _____
8. Height of Frame to PCB :	<input type="checkbox"/> Pass	<input type="checkbox"/> NG , _____
9. Height of Module :	<input type="checkbox"/> Pass	<input type="checkbox"/> NG , _____
10. Others :	<input type="checkbox"/> Pass	<input type="checkbox"/> NG , _____

**3 、 Relative Hole Size :**

1. Pitch of Connector :	<input type="checkbox"/> Pass	<input type="checkbox"/> NG , _____
2. Hole size of Connector :	<input type="checkbox"/> Pass	<input type="checkbox"/> NG , _____
3. Mounting Hole size :	<input type="checkbox"/> Pass	<input type="checkbox"/> NG , _____
4. Mounting Hole Type :	<input type="checkbox"/> Pass	<input type="checkbox"/> NG , _____
5. Others :	<input type="checkbox"/> Pass	<input type="checkbox"/> NG , _____

**4 、 Backlight Specification :**

1. B/L Type :	<input type="checkbox"/> Pass	<input type="checkbox"/> NG , _____
2. B/L Color :	<input type="checkbox"/> Pass	<input type="checkbox"/> NG , _____
3. B/L Driving Voltage (Reference for LED Type) :	<input type="checkbox"/> Pass	<input type="checkbox"/> NG , _____
4. B/L Driving Current :	<input type="checkbox"/> Pass	<input type="checkbox"/> NG , _____
5. Brightness of B/L :	<input type="checkbox"/> Pass	<input type="checkbox"/> NG , _____
6. B/L Solder Method :	<input type="checkbox"/> Pass	<input type="checkbox"/> NG , _____
7. Others :	<input type="checkbox"/> Pass	<input type="checkbox"/> NG , _____

>> **Go to page 2** <<

<b>Module Number :</b> _____		
<b>5 · <u>Electronic Characteristics of Module</u> :</b>		
1.Input Voltage :	<input type="checkbox"/> Pass	<input type="checkbox"/> NG , _____
2.Supply Current :	<input type="checkbox"/> Pass	<input type="checkbox"/> NG , _____
3.Driving Voltage for LCD :	<input type="checkbox"/> Pass	<input type="checkbox"/> NG , _____
4.Contrast for LCD :	<input type="checkbox"/> Pass	<input type="checkbox"/> NG , _____
5.B/L Driving Method :	<input type="checkbox"/> Pass	<input type="checkbox"/> NG , _____
6.Negative Voltage Output :	<input type="checkbox"/> Pass	<input type="checkbox"/> NG , _____
7.Interface Function :	<input type="checkbox"/> Pass	<input type="checkbox"/> NG , _____
8.LCD Uniformity :	<input type="checkbox"/> Pass	<input type="checkbox"/> NG , _____
9.ESD test :	<input type="checkbox"/> Pass	<input type="checkbox"/> NG , _____
10.Others :	<input type="checkbox"/> Pass	<input type="checkbox"/> NG , _____
<b>6 · <u>Summary</u> :</b>		
<p style="text-align: right;">Sales signature : _____</p> <p style="text-align: right;">Customer Signature : _____      <u>Date</u> :   /   / _____</p>		

## X-ON Electronics

Largest Supplier of Electrical and Electronic Components

*Click to view similar products for [TFT Displays & Accessories](#) category:*

*Click to view products by [Raystar](#) manufacturer:*

Other Similar products are found below :

[OAI-80038AA-2013-A](#) [HDA430T-3G1H](#) [EA CARREDIPTFT02](#) [NL6448BC20-21D](#) [NB7W-KBA04](#) [NB-ATT01](#) [NB5Q-ATT01](#) [NB5Q-KBA04](#) [NB-CN001](#) [NL12880BC20-05](#) [NL8060BC26-35C](#) [NL8060BC26-35F](#) [TCG104SVLQAPNN-AN20](#) [OAI-80038AA-2008-A](#) [315-U004B15300](#) [UMSH-8596MD-34T \(REV D\)](#) [98-0003-3490-8](#) [1044278](#) [1029309](#) [1060549](#) [DE 127-TU-30/7,5](#) [DE 128-TU-20/7,5](#) [EP-LK007TFTPCAP](#) [FR7.0A00](#) [RC2002A-TIG-CSX](#) [NL6448BC2021C](#) [TX17D01VM2EAB](#) [TX14D23VM5BAA](#)  
[TCG121WXLRXVNNANX35](#) [EIC-LCD-1080P](#) [T272480C07VR01](#) [1060632](#) [TCG070WVLPAAANN-AN50](#) [TCG035QVLPDANN-GN50](#)  
[1060630](#) [RFE430V-AIW-DNG](#) [T-55619GD065J-LW-ABN](#) [NHD-1.8-128160EF-SSXN-FT](#) [TCG104SVLPEANN-AN30](#) [NL6448BC33-70](#)  
[NL192108BC18-06F](#) [NLB150XG02L-01](#) [NL6448BC20-30D](#) [NL10276BC16-06](#) [NL192108AC10-01D](#) [NL6448AC18-08F](#) [NL6448BC20-30F](#)  
[NL12880BC20-05BD](#) [NL12880BC20-05D](#) [NL8060BC26-35BA](#)