



RAYSTAR

曜凌光電股份有限公司

住址: 42878 台中市大雅区科雅路 25 號 5F WEB: <http://www.Raystar-Optronics.com>
5F., No.25, Keya Rd., Daya Dist., Taichung E-mail: sales@raystar-optronics.com
City 428, Taiwan Tel:886-4-2565-0761 Fax : 886-4-2565-0760

RFF800P-1IW-DBS

SPECIFICATION

CUSTOMER:

APPROVED BY	
PCB VERSION	
DATE	

FOR CUSTOMER USE ONLY

SALES BY	APPROVED BY	CHECKED BY	PREPARED BY

Release DATE:

TFT Display Inspection Specification: <https://www.raystar-optronics.com/download/products.htm>

Precaution in use of TFT module: <https://www.raystar-optronics.com/download/declaration.htm>

Revision History

VERSION	DATE	REVISED PAGE NO.	Note
0	2015/12/01		First issue
A	2016/01/21		Modify Static electricity test
B	2016/08/11		Modify Vibration test
C	2018/10/12		Modify contour drawing

RAYSTAR OPTRONICS

Contents

1. Module Classification Information
2. Summary
3. General Specification
4. Interface
5. Contour Drawing
6. Block Diagram
7. Absolute Maximum Ratings
8. Electrical Characteristics
9. DC Characteristics
10. AC Characteristics
11. Optical Characteristics
12. Reliability
13. Touch Panel Information
14. Initial Code For Reference
15. Other

1. Module Classification Information

R	F	F	80	0P	-	1	I	W	-	D	B	S
1	2	3	4	5	-	6	7	8	-	9	10	11

Item	Description	
1	R : Raystar Optronics Inc.	
2	Display Type : F→TFT Type, J→ Custom TFT	
3	Solution: A: 128x160 B:320x234 C:320x240 D:480x234 E:480x272 F:800x480 G:640x480 H:1024x600 I:320x480 J:240x320 K:1280x800 L:240x400 M:1024x768 N:128x128 O:480x800 P:640x320 Q:800x600 S:480x128 T:800x320	
4	Display Size : 8.0" TFT	
5	Version Code.	
6	Model Type: A : TFT LCD E : TFT+FR+CONTROL BOARD J : TFT+FR+A/D BOARD N : TFT+FR+A/D BOARD+CONTROL BOARD S : TFT+FR+POWER BOARD (DC TO DC) 1 : TFT+CONTROL BOARD	6 : TFT+FR H : TFT+D/V BOARD I : TFT+FR+D/V BOARD B : TFT+POWER BD
7	Polarizer Type, Temperature range, View direction	I→Transmissive, W. T, 6:00 ; C→Transmissive, N. T, 6:00 L→Transmissive, W.T,12:00 ; F→Transmissive, N.T,12:00 Y→Transmissive,W.T, IPS TFT ; A→Transmissive, N.T, IPS TFT Z→Transmissive, W.T, O-TFT R→Transmissive, Super W.T, O-TFT N→Transmissive, Super W.T, 6:00; Q→Transmissive, Super W.T, 12:00 V→Transmissive, Super W.T, VA TFT
8	Backlight	W : LED, White H : LED, High Light White F : CCFL, White
9	Driver Method	D: Digital A: Analog L : LVDS M:MIPI
10	Interface	N : without control board A : 8Bit B : 16Bit S:SPI Interface R: RS232 U:USB I: I2C
11	TS	N : Without TS S : resistive touch panel C : capacitive touch panel capacitive touch panel (G-F-F) G : capacitive touch panel(G-G)

2.Summary

TFT 8.0" is a TN transmissive type color active matrix TFT liquid crystal display that use amorphous silicon TFT as switching devices. This module is a composed of a TFT_LCD module, It is usually designed for industrial application and this module follows RoHs.

RAYSTAR OPTRONICS

3.General Specifications

- Size: 8.0 inch
- Dot Matrix: 800 x RGBx480(TFT) dots
- Module dimension: 192.8(W) x 116.9(H) x 13.6(D) mm
- Active area: 176.64 x 99.36 mm
- Dot pitch: 0.0736x 0.2070 mm
- LCD type: TFT, Normally White ,Transmissive
- View Direction: 12 o'clock
- Gray Scale Inversion Direction: 6 o'clock
- Aspect Ratio: 16:9
- Backlight Type: LED,Normally White
- Controller IC: RA8875
- Interface: Digital 8080 family MPU
- With /Without TP: With RTP
- Surface: Anti-Glare

*Color tone slight changed by temperature and driving voltage.

4.Interface

4.1. LCM PIN Definition

TFT LCD Panel Driving Section

FPC Connector is used for the module electronics interface.

Pin	Symbol	Function	Remark
1	GND	System ground	
2	VDD	Power Supply : +3.3V	
3	NC	No connection	
4	RS	Data/Command select	
5	WR	Write strobe signal	
6	RD	Read strobe signal	
7	DB0	Data bus	
8	DB1	Data bus	
9	DB2	Data bus	
10	DB3	Data bus	
11	DB4	Data bus	
12	DB5	Data bus	
13	DB6	Data bus	
14	DB7	Data bus	
15	DB8	Data bus	
16	DB9	Data bus	
17	DB10	Data bus	
18	DB11	Data bus	
29	DB12	Data bus	
20	DB13	Data bus	
21	DB14	Data bus	
22	DB15	Data bus	
23	WAIT	Wait Signal Output(H:active)	
24	INT_RTP	RTP Interrupt	
25	CS	Chip select	
26	RESET	Hardware reset	
27	LR	Left / right selection; Default L/R=H	Note 2,3
28	UD	Up/down selection; ; Default U/D=L	Note 2,3
29	NC	No connection	
30	NC	No connection	
31	NC	No connection	
32	NC	No connection	
33	VLED-	Power for LED backlight cathode(GND)	
34	VLED-	Power for LED backlight cathode(GND)	
35	VLED+	Power for LED backlight anode(+5V)	
36	VLED+	Power for LED backlight anode(+5V)	

Note1: When select 8bit mode, DB0~DB7 be used, DB8~DB15 no connect
 When select 16bit mode, DB0~DB15 be used

Note 2: Selection of scanning mode

Setting of scan control input		Scanning direction
UD	LR	
GND	VDD	Up to down, left to right
VDD	GND	Down to up, right to left
GND	GND	Up to down, right to left
VDD	VDD	Down to up, left to right

Note 3: Definition of scanning direction. Refer to the figure as below:



UD=L, LR=H

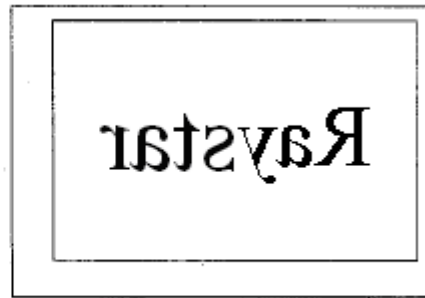

UD=L, LR=L

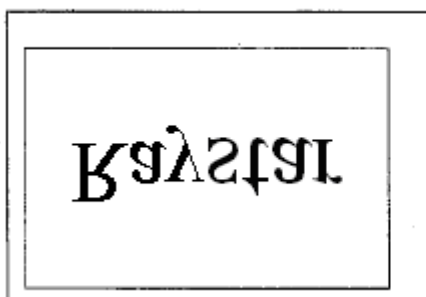

UD=H, LR=H

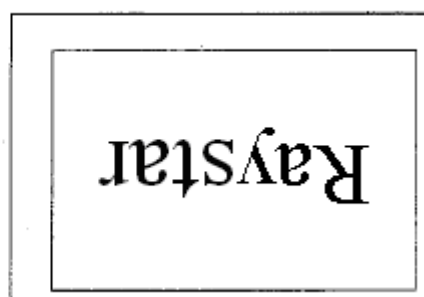

UD=H, LR=L

5. Contour Drawing

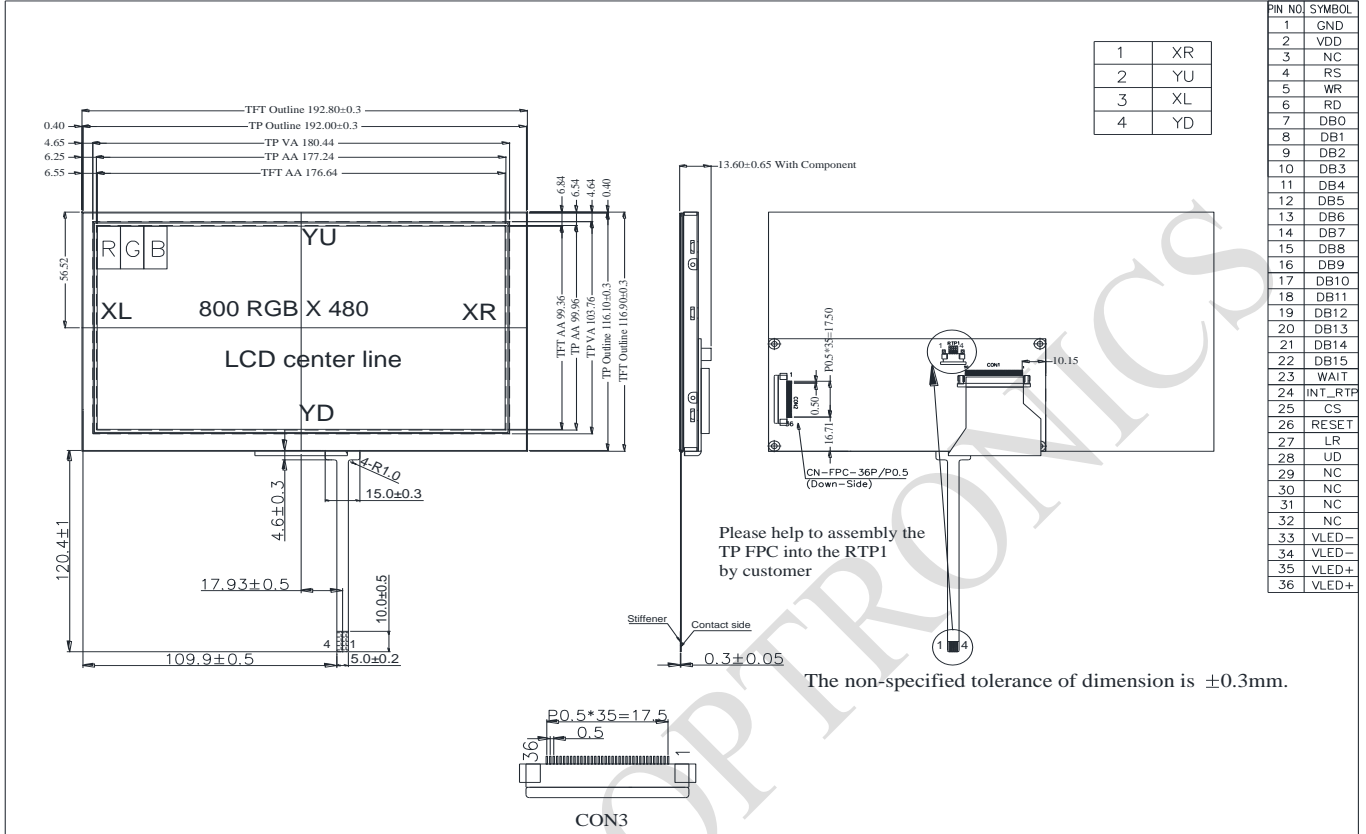

6. Block Diagram

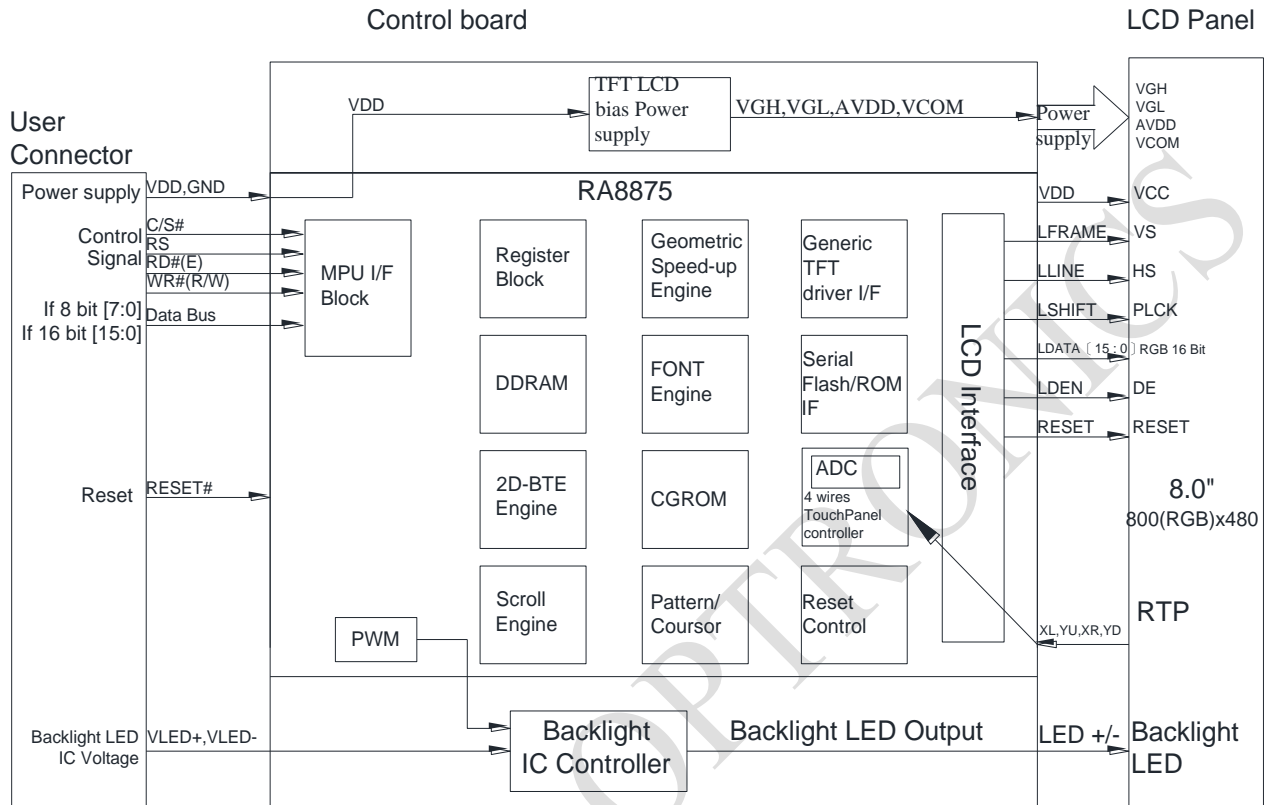

7. Absolute Maximum Ratings

Item	Symbol	Min	Typ	Max	Unit
Operating Temperature	TOP	-20	—	+70	°C
Storage Temperature	TST	-30	—	+80	°C

Note: Device is subject to be damaged permanently if stresses beyond those absolute maximum ratings listed above

- Temp. $\leq 60^{\circ}\text{C}$, 90% RH MAX. Temp. $> 60^{\circ}\text{C}$, Absolute humidity shall be less than 90% RH at 60°C

RAYSTAR OPTRONICS

8. Electrical Characteristics

8.1. Operating conditions: (CON2.Pin1=GND, Pin2=VDD)

Item	Symbol	Condition	Min	Typ	Max	Unit	Remark
Supply Voltage For LCM	VDD	—	3.0	3.3	3.6	V	—
Supply Current For LCM	IDD	—	-	199	300	mA	Note1

Note 1 : This value is test for VDD=3.3V , Ta=25°C only

8.2. Backlight driving conditions (CON2.Pin33,34=VLED-, Pin35,36=VLED+)

Parameter	Symbol	Min.	Typ.	Max.	Unit	Remark
Operation Current For LED Driver	VLED=5V	600	—	900	mA	Note 1,2
Power Consumption	VLED=5V	3000	—	4500	mW	Note 1,2
Supply Voltage For LED Driver	VLED+	—	5	—	V	—
LED Life Time	—	20,000	—	—	Hr	Note 2,3,4

Note 1 : Base on VLED= 5V for the back light driver IC specification

Note 2 : Ta = 25 °C

Note 3 : Brightness to be decreased to 50% of the initial value

Note 4 : The single LED lamp case

9.DC CHARATERISTICS

Parameter	Symbol	Rating			Unit	Condition
		Min	Typ	Max		
Low level input voltage	VIL	GND	-	0.2 VDD	V	
High level input voltage	VIH	0.8 VDD	-	VDD	V	

RAYSTAR OPTRONICS

10.AC CHARATERISTICS

10.1. Parallel I/F Protocol

The following timing charts are used to describe the timing specification of the standard 8080 and 6800 interfaces.

6800 – 8/16-bit Interface

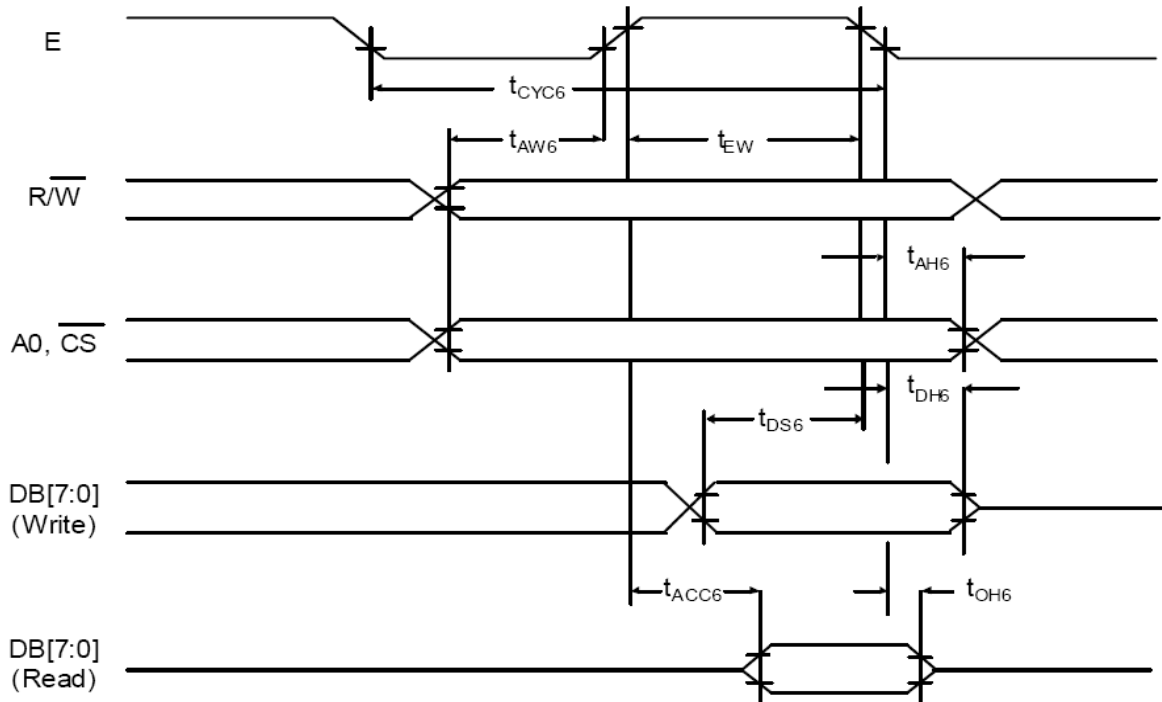

Figure 1: 6800 MCU Waveform

Table 1: 6800 MCU I/F Timing

Symbol	Parameter	Rating		Unit	Symbol
		Min.	Max		
t_{CYC6}	Cycle time	50	--	ns	t_c is one system clock period: $t_c = 1/SYS_CLK$
t_{EW}	Strobe Pulse width	20	--	ns	
t_{AW6}	Address setup time	0	--	ns	
t_{AH6}	Address hold time	10	--	ns	
t_{DS6}	Data setup time	20	--	ns	
t_{DH6}	Data hold time	10	--	ns	
t_{ACC6}	Data output access time	0	20	ns	
t_{OH6}	Data output hold time	0	20	ns	

8080 – 8/16-bit Interface

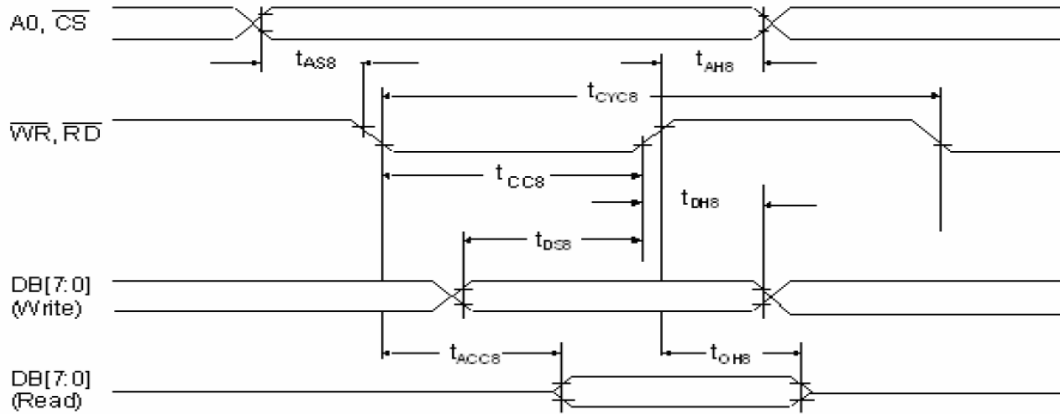

Figure 2: 8080 Waveform
Table 2: 8080 MCU I/F Timing

Symbol	Parameter	Rating		Unit	Symbol
		Min.	Max.		
tCYC8	Cycle time	50	--	ns	tc is one system clock period: tc = 1/SYS_CLK
tCC8	Strobe Pulse width	20	--	ns	
tAS8	Address setup time	0	--	ns	
tAH8	Address hold time	10	--	ns	
tDS8	Data setup time	20	--	ns	
tDH8	Data hold time	10	--	ns	
tACC8	Data output access time	0	20	ns	
tOH8	Data output hold time	0	20	ns	

The data bus width of RA8875 can be selected to 8-bit/16-bit by setting the Bit [1:0] of SYSR. When Bit [1:0] of SYSR is cleared to “00”, then the data bus is 8-bit. If Bit [1:0] of SYSR is set to “11”, then the data transition is set as 16-bit. No matter what type of MCU I/F is selected (6800/8080), both of them can be changed the bus width when need. But if the 8-bit is used, it needs double transmission time than 16-bit bus and all of the registers must be accessed by 8-bit data.

The continuous data write speed determines the display update speed. The cycle-to-cycle interval must be larger than 4 times of system clock period. Over the specification may cause the data lose or function fail. Please refer to Figure 6-5 and Figure 6-6 for waveform detail. In order to reduce the transmission interference between MCU interface and RA8875, It is suggested that a small capacitor to the GND should be added at the signal of CS#, RD#, and WR#. If using cable to connect MCU and RA8875, please keep the cable length less than 20cm. Otherwise it’s suggested to add 1~10Kohm pull-up resistors on pins CS#, RD#, WR# and RS.

MPU6800 Data Write Speed Limit

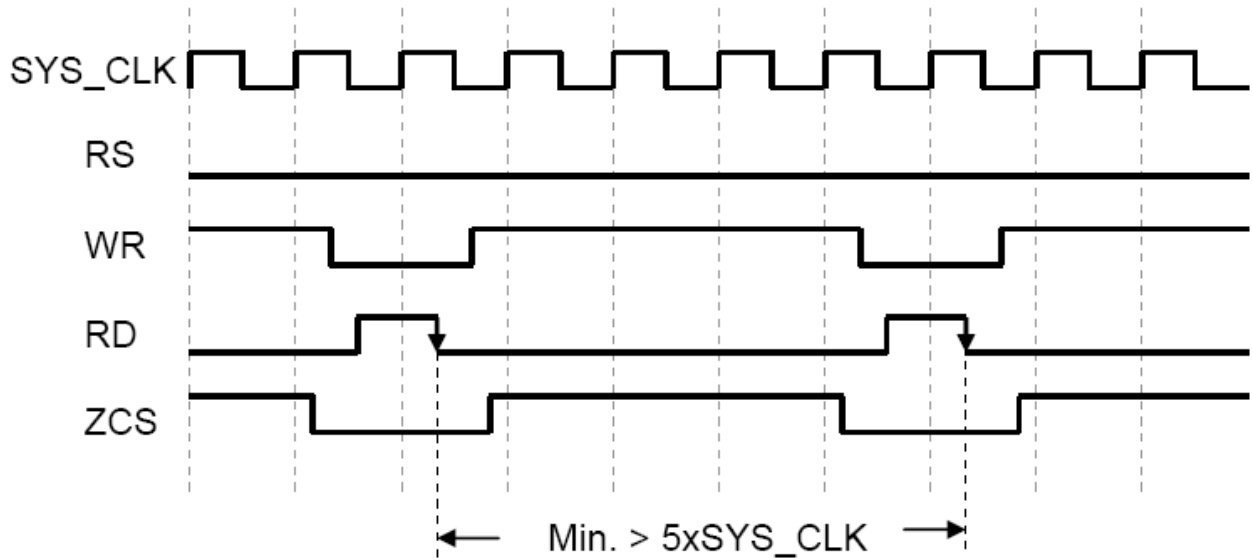

Figure 3: 6800 I/F Continuous Data Write Cycle Waveform

MPU8080 Data Write Speed Limit

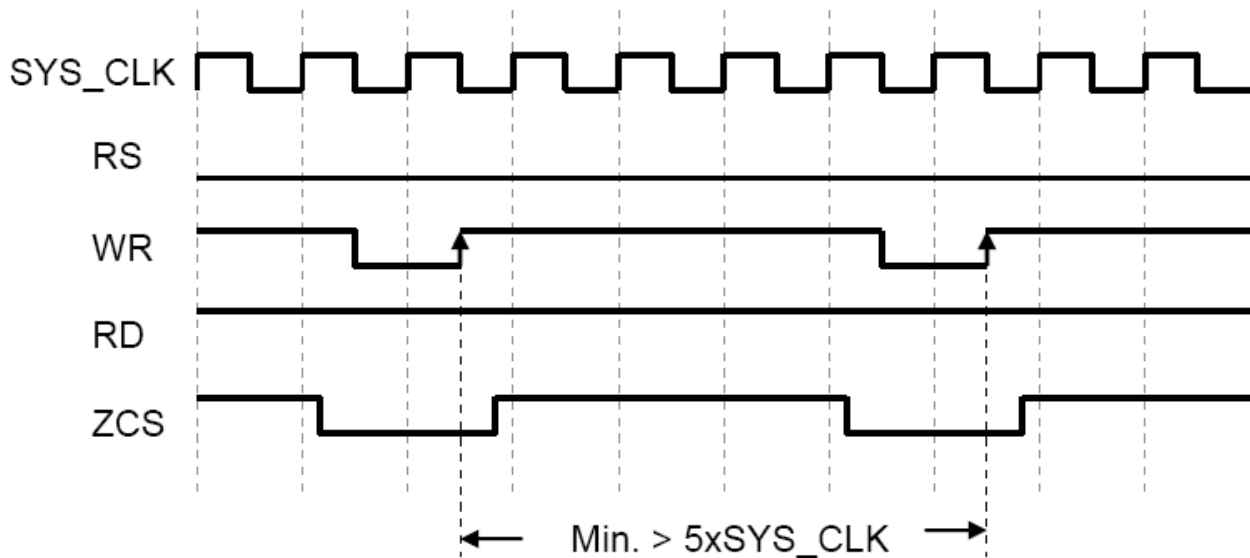

Figure4: 8080 I/F Continuous Data Write Cycle Waveform

10.2. Data transfer order Setting

MCU Data Bus 8-Bit

The following illustration is used for 16-bit MCU.

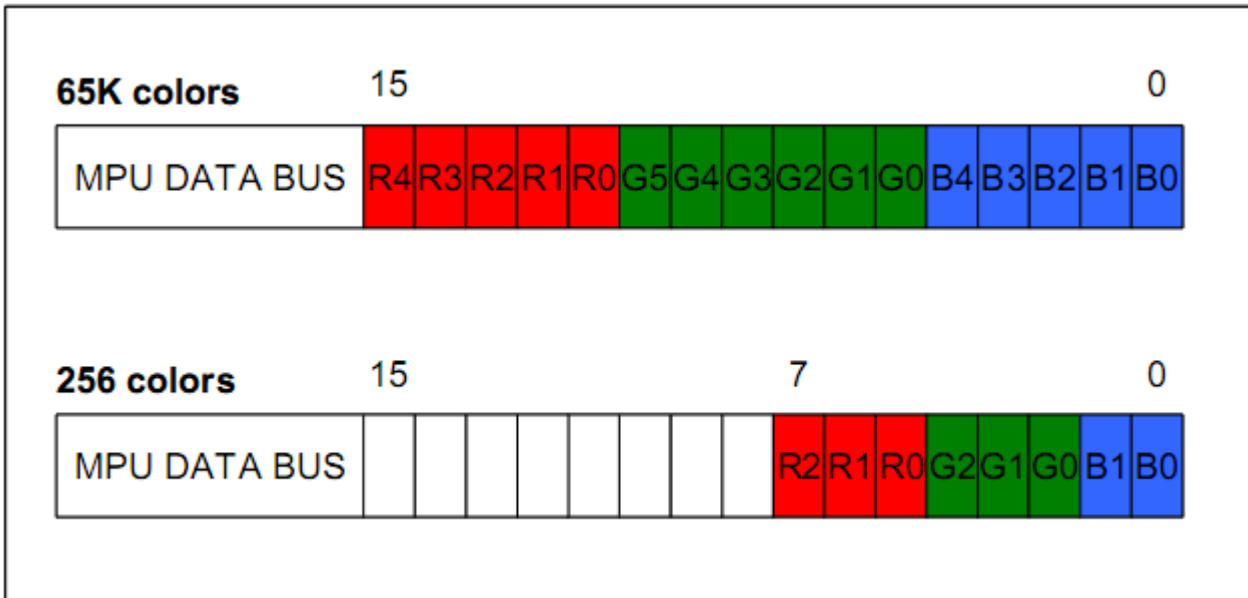

Figure 5: Color illustrations for 16-Bit Data Bus MCU

10.3. Register Depiction

Please consult the spec of RA8875

11. Optical Characteristics

Item	Symbol	Condition.	Min	Typ.	Max.	Unit	Remark
Response time	Tr	$\theta=0^\circ, \phi=0^\circ$	-	10	20	ms	Note 3,5
	Tf		-	15	30	ms	
Contrast ratio	CR	At optimized viewing angle	400	500	-	-	Note 4,5
Color Chromaticity	White	Wx	$\theta=0^\circ, \phi=0$	0.26	0.31	0.36	Note 2,5,6
		Wy		0.28	0.33	0.38	
Viewing angle (Gray Scale Inversion Direction)	Hor.	Θ_R	$CR \geq 10$	60	70	-	Note 1
		Θ_L		60	70	-	
	Ver.	Φ_T		40	50	-	
		Φ_B		60	70	-	
Brightness	-	-	250	320	-	cd/m ²	Center Of Display

Ta=25±2°C,

Note 1: Definition of viewing angle range

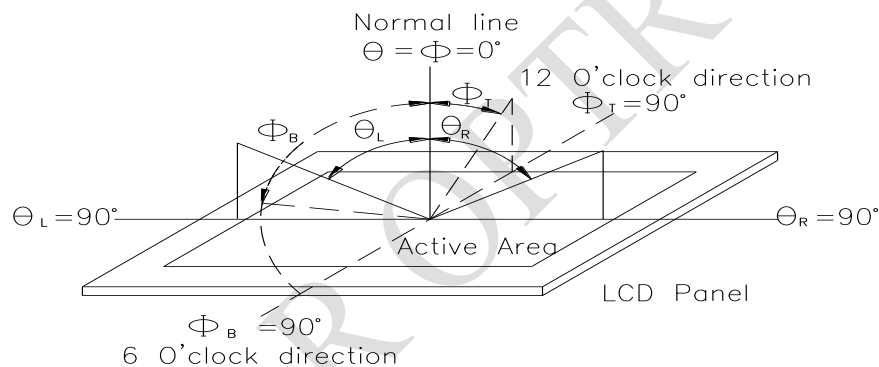

Fig. 11.1. Definition of viewing angle

Note 2: Test equipment setup:

After stabilizing and leaving the panel alone at a driven temperature for 10 minutes, the measurement should be executed. Measurement should be executed in a stable, windless, and dark room. Optical specifications are measured by Topcon BM-7 or BM-5 luminance meter 1.0° field of view at a distance of 50cm and normal direction.

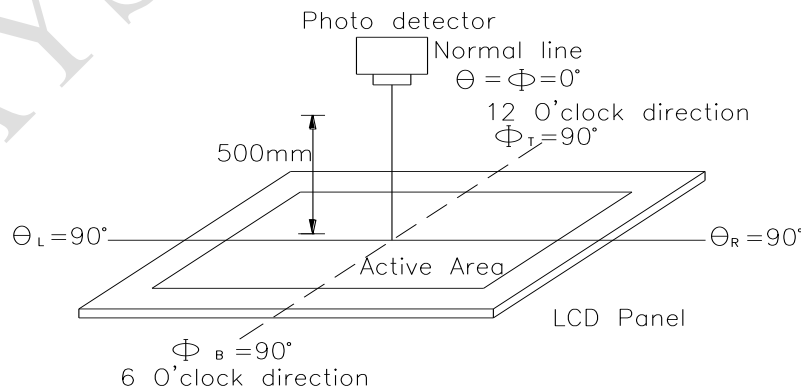
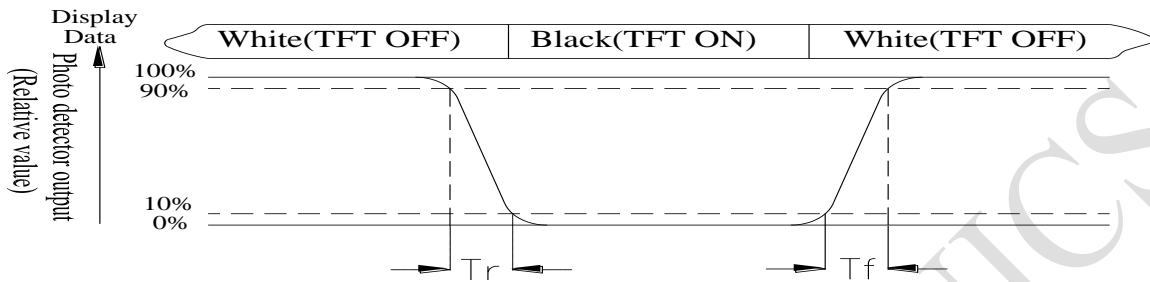

Fig. 11.2. Optical measurement system setup

Note 3: Definition of Response time:

The response time is defined as the LCD optical switching time interval between “White” state and “Black” state. Rise time, T_r , is the time between photo detector output intensity changed from 90% to 10%. And fall time, T_f , is the time between photo detector output intensity changed from 10% to 90%



Note 4: Definition of contrast ratio:

The contrast ratio is defined as the following expression.

$$\text{Contrast ratio (CR)} = \frac{\text{Luminance measured when LCD on the "White" state}}{\text{Luminance measured when LCD on the "Black" state}}$$

Note 5: White $V_i = V_{i50} \pm 1.5V$

Black $V_i = V_{i50} \pm 2.0V$

“±” means that the analog input signal swings in phase with VCOM signal.

“±” means that the analog input signal swings out of phase with VCOM signal.

The 100% transmission is defined as the transmission of LCD panel when all the input terminals of module are electrically opened.

Note 6: Definition of color chromaticity (CIE 1931)

Color coordinates measured at the center point of LCD

Note 7: Measured at the center area of the panel when all the input terminals of LCD panel are electrically opened.

12. Reliability

Content of Reliability Test (Wide temperature, -20°C ~70°C)

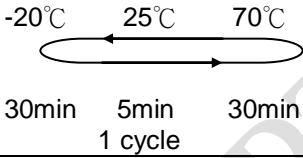
Environmental Test			
Test Item	Content of Test	Test Condition	Note
High Temperature storage	Endurance test applying the high storage temperature for a long time.	80°C 200hrs	2
Low Temperature storage	Endurance test applying the low storage temperature for a long time.	-30°C 200hrs	1,2
High Temperature Operation	Endurance test applying the electric stress (Voltage & Current) and the thermal stress to the element for a long time.	70°C 200hrs	—
Low Temperature Operation	Endurance test applying the electric stress under low temperature for a long time.	-20°C 200hrs	1
High Temperature/ Humidity Operation	The module should be allowed to stand at 60°C, 90%RH max	60°C, 90%RH 96hrs	1,2
Thermal shock resistance	The sample should be allowed stand the following 10 cycles of operation <div style="text-align: center;">  <p>-20°C 25°C 70°C</p> <p>30min 5min 30min</p> <p>1 cycle</p> </div>	-20°C/70°C 10 cycles	—
Vibration test	Endurance test applying the vibration during transportation and using.	Total fixed amplitude : 1.5mm Vibration Frequency : 10~55Hz One cycle 60 seconds to 3 directions of X,Y,Z for Each 15 minutes	3
Static electricity test	Endurance test applying the electric stress to the terminal.	VS=±600V(contact) ,±800v(air), RS=330Ω CS=150pF 10 times	—

Note1: No dew condensation to be observed.

Note2: The function test shall be conducted after 4 hours storage at the normal Temperature and humidity after remove from the test chamber.

Note3: The packing have to including into the vibration testing.

13.Touch Panel Information

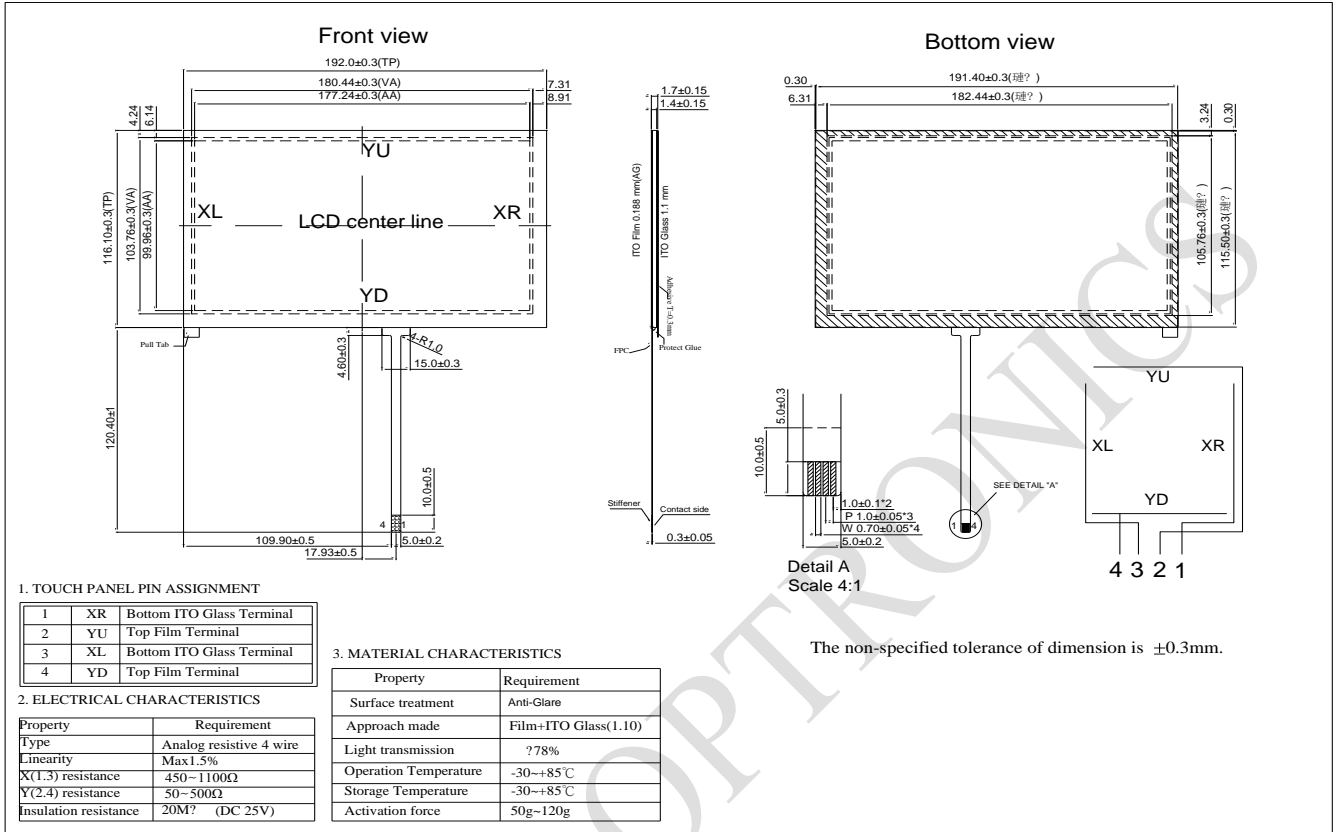

14. Initial Code For Reference

```
void Initial_RA8875()
{
    RES = 1;
    Delay1ms (10);
    RES = 0;      //Active low
    Delay1ms (50);
    RES = 1;
    Delay1ms (100);

    LCD_CmdWrite(0x88);
    LCD_DataWrite(0x0b);
    Delay1ms(1);
    LCD_CmdWrite(0x89);
    LCD_DataWrite(0x02);
    Delay1ms(1);

    LCD_CmdWrite(0x10);
    LCD_DataWrite(0x0F);
    LCD_CmdWrite(0x04);
    LCD_DataWrite(0x81);
    Delay1ms(1);

    //Horizontal set
    LCD_CmdWrite(0x14);
    LCD_DataWrite(0x63);
    LCD_CmdWrite(0x15);
    LCD_DataWrite(0x00);
    LCD_CmdWrite(0x16);
    LCD_DataWrite(0x03);
    LCD_CmdWrite(0x17);
    LCD_DataWrite(0x03);
    LCD_CmdWrite(0x18);
    LCD_DataWrite(0x0B);

    //Vertical set
    LCD_CmdWrite(0x19);
    LCD_DataWrite(0xdf);
    LCD_CmdWrite(0x1a);
    LCD_DataWrite(0x01);
    LCD_CmdWrite(0x1b);
    LCD_DataWrite(0x20);
    LCD_CmdWrite(0x1c);
    LCD_DataWrite(0x00);
    LCD_CmdWrite(0x1d);
    LCD_DataWrite(0x16);
    LCD_CmdWrite(0x1e);
    LCD_DataWrite(0x00);
```

```
LCD_CmdWrite(0x1f);  
LCD_DataWrite(0x01);
```

```
//Active window set  
//setting active window X  
LCD_CmdWrite(0x30);  
LCD_DataWrite(0x00);  
LCD_CmdWrite(0x31);  
LCD_DataWrite(0x00);  
LCD_CmdWrite(0x34);  
LCD_DataWrite(0x1F);  
LCD_CmdWrite(0x35);  
LCD_DataWrite(0x03);
```

```
//setting active window Y  
LCD_CmdWrite(0x32);  
LCD_DataWrite(0x00);  
LCD_CmdWrite(0x33);  
LCD_DataWrite(0x00);  
LCD_CmdWrite(0x36);  
LCD_DataWrite(0xdF);  
LCD_CmdWrite(0x37);  
LCD_DataWrite(0x01);
```

```
}
```

LCM Sample Estimate Feedback Sheet

Module Number : _____

1 、 Panel Specification :

1. Panel Type :	<input type="checkbox"/> Pass	<input type="checkbox"/> NG , _____
2. View Direction :	<input type="checkbox"/> Pass	<input type="checkbox"/> NG , _____
3. Numbers of Dots :	<input type="checkbox"/> Pass	<input type="checkbox"/> NG , _____
4. View Area :	<input type="checkbox"/> Pass	<input type="checkbox"/> NG , _____
5. Active Area :	<input type="checkbox"/> Pass	<input type="checkbox"/> NG , _____
6. Operating Temperature :	<input type="checkbox"/> Pass	<input type="checkbox"/> NG , _____
7. Storage Temperature :	<input type="checkbox"/> Pass	<input type="checkbox"/> NG , _____
8. Others :	_____	

2 、 Mechanical Specification :

1. PCB Size :	<input type="checkbox"/> Pass	<input type="checkbox"/> NG , _____
2. Frame Size :	<input type="checkbox"/> Pass	<input type="checkbox"/> NG , _____
3. Material of Frame :	<input type="checkbox"/> Pass	<input type="checkbox"/> NG , _____
4. Connector Position :	<input type="checkbox"/> Pass	<input type="checkbox"/> NG , _____
5. Fix Hole Position :	<input type="checkbox"/> Pass	<input type="checkbox"/> NG , _____
6. Backlight Position :	<input type="checkbox"/> Pass	<input type="checkbox"/> NG , _____
7. Thickness of PCB :	<input type="checkbox"/> Pass	<input type="checkbox"/> NG , _____
8. Height of Frame to PCB :	<input type="checkbox"/> Pass	<input type="checkbox"/> NG , _____
9. Height of Module :	<input type="checkbox"/> Pass	<input type="checkbox"/> NG , _____
10. Others :	<input type="checkbox"/> Pass	<input type="checkbox"/> NG , _____

3 、 Relative Hole Size :

1. Pitch of Connector :	<input type="checkbox"/> Pass	<input type="checkbox"/> NG , _____
2. Hole size of Connector :	<input type="checkbox"/> Pass	<input type="checkbox"/> NG , _____
3. Mounting Hole size :	<input type="checkbox"/> Pass	<input type="checkbox"/> NG , _____
4. Mounting Hole Type :	<input type="checkbox"/> Pass	<input type="checkbox"/> NG , _____
5. Others :	<input type="checkbox"/> Pass	<input type="checkbox"/> NG , _____

4 、 Backlight Specification :

1. B/L Type :	<input type="checkbox"/> Pass	<input type="checkbox"/> NG , _____
2. B/L Color :	<input type="checkbox"/> Pass	<input type="checkbox"/> NG , _____
3. B/L Driving Voltage (Reference for LED Type) :	<input type="checkbox"/> Pass	<input type="checkbox"/> NG , _____
4. B/L Driving Current :	<input type="checkbox"/> Pass	<input type="checkbox"/> NG , _____
5. Brightness of B/L :	<input type="checkbox"/> Pass	<input type="checkbox"/> NG , _____
6. B/L Solder Method :	<input type="checkbox"/> Pass	<input type="checkbox"/> NG , _____
7. Others :	<input type="checkbox"/> Pass	<input type="checkbox"/> NG , _____

>> **Go to page 2** <<

Module Number : _____		
5 · <u>Electronic Characteristics of Module</u> :		
1.Input Voltage :	<input type="checkbox"/> Pass	<input type="checkbox"/> NG , _____
2.Supply Current :	<input type="checkbox"/> Pass	<input type="checkbox"/> NG , _____
3.Driving Voltage for LCD :	<input type="checkbox"/> Pass	<input type="checkbox"/> NG , _____
4.Contrast for LCD :	<input type="checkbox"/> Pass	<input type="checkbox"/> NG , _____
5.B/L Driving Method :	<input type="checkbox"/> Pass	<input type="checkbox"/> NG , _____
6.Negative Voltage Output :	<input type="checkbox"/> Pass	<input type="checkbox"/> NG , _____
7.Interface Function :	<input type="checkbox"/> Pass	<input type="checkbox"/> NG , _____
8.LCD Uniformity :	<input type="checkbox"/> Pass	<input type="checkbox"/> NG , _____
9.ESD test :	<input type="checkbox"/> Pass	<input type="checkbox"/> NG , _____
10.Others :	<input type="checkbox"/> Pass	<input type="checkbox"/> NG , _____
6 · <u>Summary</u> :		
<p style="text-align: right; margin-right: 50px;"> Sales signature : _____ Customer Signature : _____ Date : / / _____ </p>		

X-ON Electronics

Largest Supplier of Electrical and Electronic Components

Click to view similar products for [TFT Displays & Accessories](#) category:

Click to view products by [Raystar](#) manufacturer:

Other Similar products are found below :

[OAI-80038AA-2013-A](#) [HDA430T-3G1H](#) [EA CARREDIPTFT02](#) [NL6448BC20-21D](#) [TM022HDHT11-00](#) [NB7W-KBA04](#) [NB-ATT01](#)
[NB5Q-ATT01](#) [NB5Q-KBA04](#) [NB-CN001](#) [NL12880BC20-05](#) [NL8060BC26-35C](#) [NL8060BC26-35F](#) [TCG104SVLQAPNN-AN20](#) [OAI-](#)
[80038AA-2008-A](#) [315-U004B15300](#) [UMSH-8596MD-34T \(REV D\)](#) [98-0003-3490-8](#) [1044278](#) [1029309](#) [1060549](#) [DE 127-TU-30/7,5](#) [DE](#)
[128-TU-20/7,5](#) [EP-LK007TFTPCAP](#) [FR7.0A00](#) [RC2002A-TIG-CSX](#) [NL6448BC2021C](#) [TX17D01VM2EAB](#) [TX14D23VM5BAA](#)
[TCG121WXLRXVNNANX35](#) [EIC-LCD-1080P](#) [T272480C07VR01](#) [1060632](#) [TCG070WVLPAAANN-AN50](#) [TCG035QVLPDANN-GN50](#)
[1060630](#) [RFE430V-AIW-DNG](#) [T-55619GD065J-LW-ABN](#) [NHD-1.8-128160EF-SSXN-FT](#) [TCG104SVLPEANN-AN30](#) [NL6448BC33-70](#)
[NL192108BC18-06F](#) [NLB150XG02L-01](#) [NL6448BC20-30D](#) [NL10276BC16-06](#) [NL192108AC10-01D](#) [NL6448AC18-08F](#) [NL6448BC20-30F](#)
[NL12880BC20-05BD](#) [NL12880BC20-05D](#)