

Features

Evaluation Module

- 3.3V from a single AA battery or from an external source (boost converter)
- Efficiency 93%, >80% at 10% load
- Input voltage range down to 0.65V
- Input and output power measurement capability
- Micro-USB type B or 0.100" (2.54mm) pin output

Description

The R-78S3.3-0.1-EVM-1 Evaluation Module generates 3.3V from a single AA battery or from an external source. By using the external input source, any voltage source (other types of batteries, energy harvesters, etc.) in the range from 0.65V to 3.15V can be used. The evaluation module contains a AA battery holder, power switch, R-78S3.3-0.1 boost converter and a micro-USB connector. Jumper headers are provided to allow various test measurements to be made. An enable pin puts the R-78S into sleep mode where it draws only 7uA from the battery.

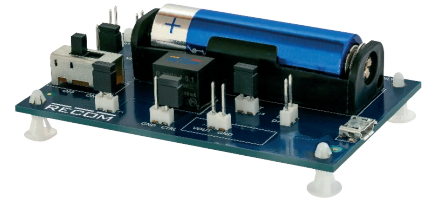

Selection Guide

Part Number	Input Voltage Range ⁽³⁾ [VDC]	Output Voltage [VDC]	Output Current [mA]	Efficiency ⁽¹⁾		Max. Capacitive Load ⁽²⁾ [μF]
				@ min Vin [%]	@ typ. Vin [%]	
R-78S3.3-0.1	0.65-3.15	3.3	100	92	93	470

Specifications (measured @ ta= 25°C, 1.5Vin, full load after warm up unless otherwise stated)

BASIC CHARACTERISTICS

Parameter	Condition	Min.	Typ.	Max.
Under Voltage Lockout	DC-DC OFF		0.4VDC	
Overload Capability ⁽³⁾	peak duty cycle 10%		150%, 10s	
Quiescent Current			160μA	
Start-up Time			2ms	
Rise Time			800μs	
Internal Operating Frequency			1200kHz	
Minimum Load		0%		
Dropout Voltage			150mV	
Output Ripple and Noise			100mVp-p	
ON/OFF CTRL	DC-DC ON DC-DC OFF		Open or 0.7V ≤ VCTRL < Vin Short to GND or VCTRL < 0.1V	
Input Current of CTRL Pin			5μA	
Standby Current			7μA	

Notes:

Note1: Efficiency is tested at full load. Typ. Vin = 1.5V

Note2: Max. capacitive load is tested at nominal input and full resistive load

Note3: For more information, please refer to "Overload Capability Graph" on page P-2

Specifications (measured @ $t_a = 25^\circ\text{C}$, 1.5V_{in} , full load after warm up unless otherwise stated)

Overload Capability Graph

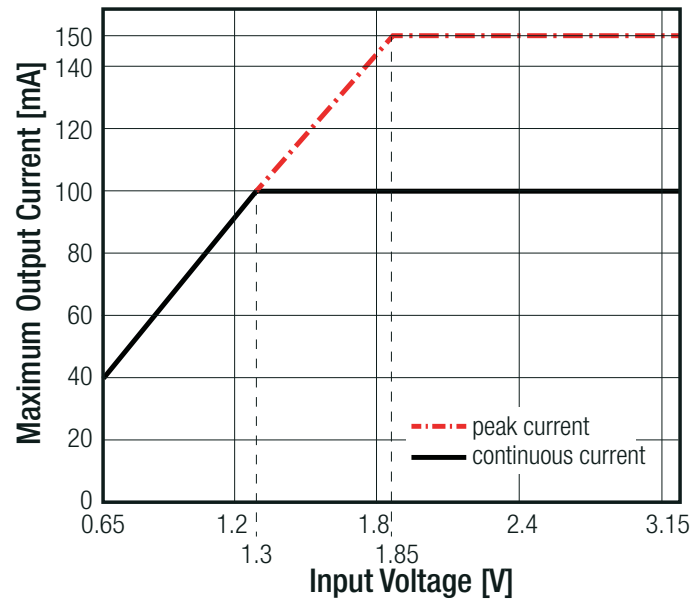

Quick Start Guide

- Insert the AA battery into the battery holder (only one way possible).
- If powering USB-powered demonstrators: plug in the micro-USB cable.
- Turn on and off using the slide switch.
 - Note: to reduce the power consumption, no indicator LED is fitted. Remember to switch off to conserve the battery.
- The output voltage is accessed via J7 or the USB port.
- To measure the input and output current of the R-78S, remove the jumpers on J4 and J5. J4 and J5 are standard 0.100" (2.54mm) pin headers to allow current measurement device connections (ampere meter, scope probe).
- When an external voltage source (no on-board battery) is used on J3, change the jumper position on J1 to pin 1 and pin 2 (VEXT).
- When the on-board AA battery is used, change the jumper position on J1 to pin 2 and pin 3 (VBAT).
- To set the R-78S into sleep mode, apply the provided jumper on both pins of J6 (CTRL to GND).

Component Placement

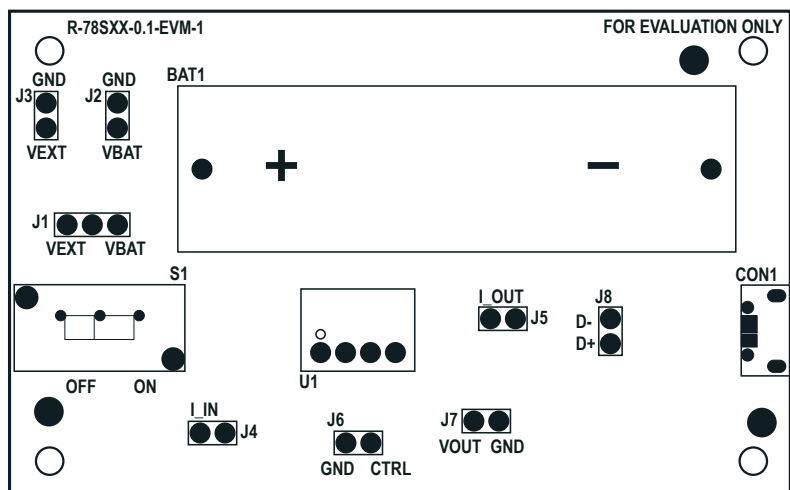

Specifications (measured @ ta= 25°C, 1.5Vin, full load after warm up unless otherwise stated)

Component List		
Part	Description	Setting
BAT1	AA battery holder	
J1	3 pin 0.100" (2.54mm) header for VEXT and VBAT	Factory set to on-board battery
J2*	2 pin 0.100" (2.54mm) header for VBAT and GND	Leave open if not used
J3	2 pin 0.100" (2.54mm) header for VEXT and GND	Leave open if not used
J4	2 pin 0.100" (2.54mm) header for input current	Leave closed if not used
J5	2 pin 0.100" (2.54mm) header for output current	Leave closed if not used
J6	2 pin 0.100" (2.54mm) header for CTRL (enable) and GND	Leave open if not used
J7	2 pin 0.100" (2.54mm) header for VOUT and GND	Leave open if not used
J8	2 pin 0.100" (2.54mm) header for USB D+ and D-	Leave open if not used
S1	Slide switch	Factory set OFF
CON1	USB micro B connector	
U1	R-78S3.3-0.1 boost converter	

***Caution:**

DO NOT PLACE A JUMPER ON J2. DOING SO WILL CAUSE THE BATTERY TO SHORT CIRCUIT AND CREATE THE RISK OF FIRE.

Schematic

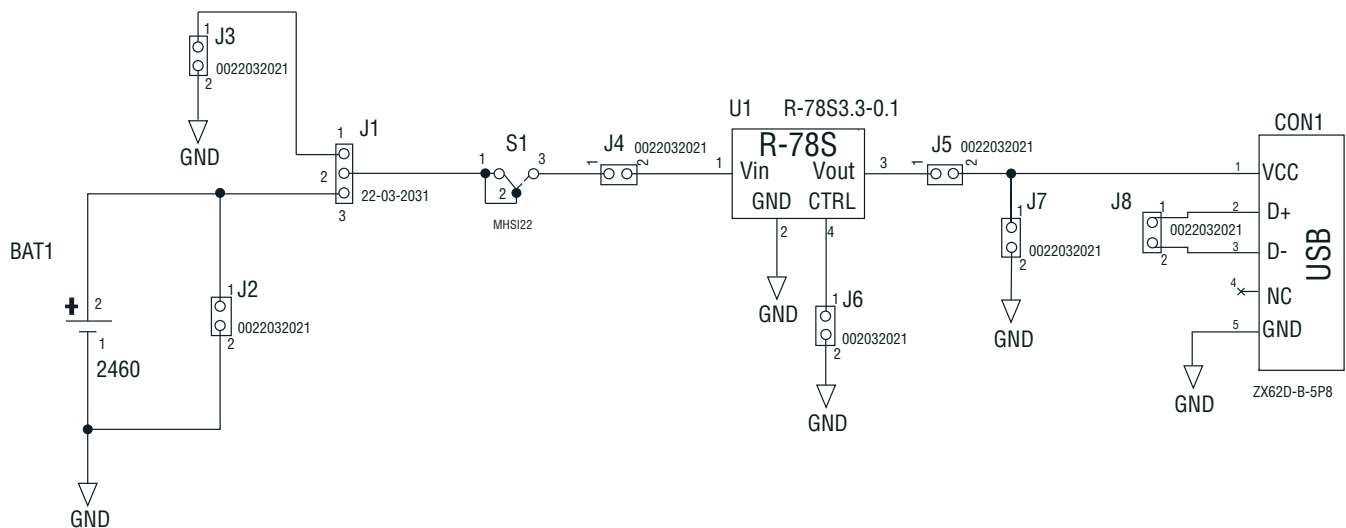

Specifications (measured @ ta= 25°C, 1.5Vin, full load after warm up unless otherwise stated)

DIMENSION AND PHYSICAL CHARACTERISTICS

Parameter	Type	Value
Dimension (LxWxH)		80.0 x 50.0 x 23.0mm
Weight		26g typ.

Layout

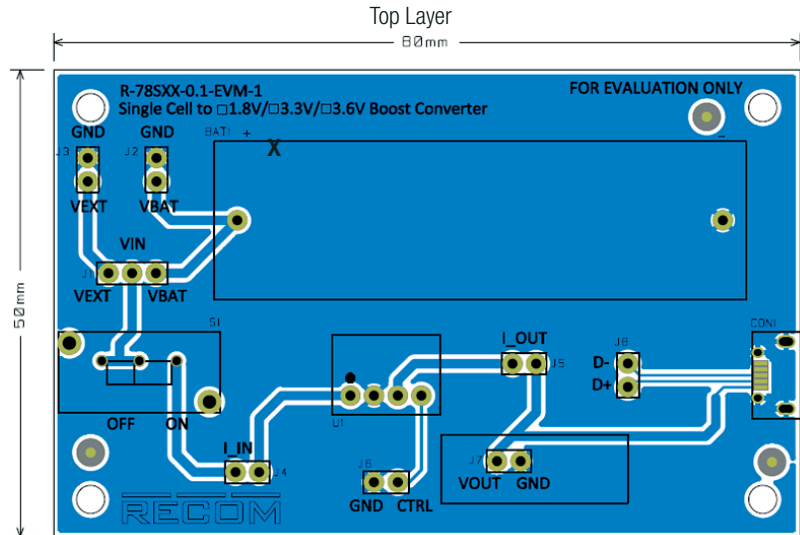

Bottom Layer

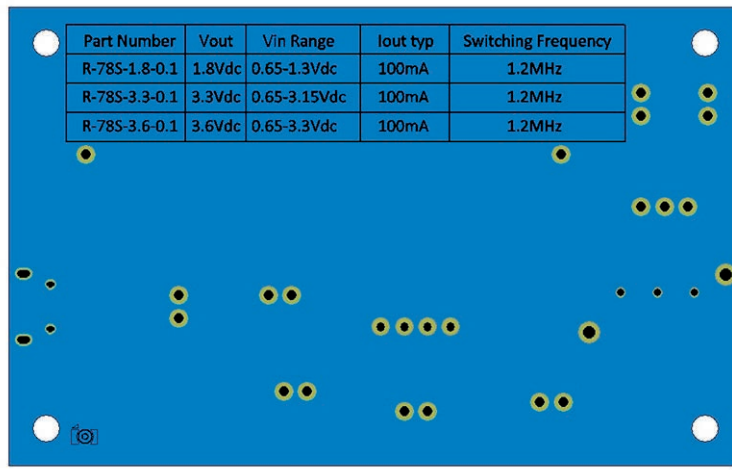

BOM

Part Name/Number	Description	Manufacturer Part Number	Manufacturer	Qty.	Comps.
Battery_Holder_AA	Holder Battery 1Cell AA PCB MNT	2460	Keystone Electronics	1	BAT1
JUMPER_2PINS	2 Positions Header Connector 0.100" (2.54mm) Through Hole Tin	0022032021	Molex	7	J2 J3 J4 J5 J6 J7 J8
JUMPER_3PINS	Conn Header 3POS .100 Vert Tin	22-03-2031	Molex	1	J1
MHS122	Switch Slide SPDT 300mA 30V	MHS122	APEM Inc	1	S1
R-78S3.3-0.1	DC DC Converter 3.3V	R-78S3.3-0.1	RECOM	1	U1
ZX62D-B-5P8	Conn RCPT USB Micro B SMD	ZX62D-B-5P8	Hirose Electric Co Ltd	1	CON1

Specifications (measured @ $t_a = 25^\circ\text{C}$, 1.5Vin, full load after warm up unless otherwise stated)

PACKAGING INFORMATION

Parameter	Type	Value
Packaging Dimension (LxWxH)	carton	200.0 x 135.0 x 68.0mm
Packaging Quantity		1 pcs

Contents

- R-78S3.3-0.1-EVM-1 Evaluation Module PBA
- Micro-USB Type B to Micro-USB Type B Cable
- Terms and Conditions Letter

The product information and specifications may be subject to changes even without prior written notice. The product has been designed for various applications; its suitability lies in the responsibility of each customer. The products are not authorized for use in safety-critical applications without RECOM's explicit written consent. A safety-critical application is an application where a failure may reasonably be expected to endanger or cause loss of life, inflict bodily harm or damage property. The applicant shall indemnify and hold harmless RECOM, its affiliated companies and its representatives against any damage claims in connection with the unauthorized use of RECOM products in such safety-critical applications.

X-ON Electronics

Largest Supplier of Electrical and Electronic Components

Click to view similar products for [Power Management IC Development Tools](#) category:

Click to view products by [Recom Power](#) manufacturer:

Other Similar products are found below :

[EVAL-ADM1168LQEBZ](#) [EVB-EP5348UI](#) [MIC23451-AAAYFL EV](#) [MIC5281YMME EV](#) [DA9063-EVAL](#) [ADP122-3.3-EVALZ](#) [ADP130-0.8-EVALZ](#) [ADP130-1.2-EVALZ](#) [ADP130-1.5-EVALZ](#) [ADP130-1.8-EVALZ](#) [ADP1714-3.3-EVALZ](#) [ADP1716-2.5-EVALZ](#) [ADP1740-1.5-EVALZ](#) [ADP1752-1.5-EVALZ](#) [ADP1828LC-EVALZ](#) [ADP1870-0.3-EVALZ](#) [ADP1871-0.6-EVALZ](#) [ADP1873-0.6-EVALZ](#) [ADP1874-0.3-EVALZ](#) [ADP1882-1.0-EVALZ](#) [ADP199CB-EVALZ](#) [ADP2102-1.25-EVALZ](#) [ADP2102-1.875EVALZ](#) [ADP2102-1.8-EVALZ](#) [ADP2102-2-EVALZ](#) [ADP2102-3-EVALZ](#) [ADP2102-4-EVALZ](#) [ADP2106-1.8-EVALZ](#) [ADP2147CB-110EVALZ](#) [AS3606-DB](#) [BQ24010EVM](#) [BQ24075TEVM](#) [BQ24155EVM](#) [BQ24157EVM-697](#) [BQ24160EVM-742](#) [BQ24296MEVM-655](#) [BQ25010EVM](#) [BQ3055EVM](#) [NCV891330PD50GEVB](#) [ISLUSBI2CKIT1Z](#) [LM2744EVAL](#) [LM2854EVAL](#) [LM3658SD-AEV/NOPB](#) [LM3658SDEV/NOPB](#) [LM3691TL-1.8EV/NOPB](#) [LM4510SDEV/NOPB](#) [LM5033SD-EVAL](#) [LP38512TS-1.8EV](#) [EVAL-ADM1186-1MBZ](#) [EVAL-ADM1186-2MBZ](#)